



Date: ~~Nov-Dec 2021~~2022

Space Telecommunications Interface (STI) 1.0

Submission to MARS SNC TF in Response to STI RFP (mars/19-09-21)

Version 1.0 – beta 2

OMG Document Number: ~~ptc/2021-11-01~~ ptc/20242022-4412-2603

Normative reference: <https://www.omg.org/spec/STI/1.0/>

Machine readable file(s):

Normative: ~~<https://www.omg.org/spec/STI/20211101/ptc/21-11-28>~~
<https://www.omg.org/spec/STI/20221201>

Field Code Changed

This OMG document replaces the submission document (mars/2020-11-01 and ptc/2021-01-03). It is an OMG Adopted Beta Specification. Comments on the content of this document are welcome and should be directed to issues@omg.org. You may view the pending issues for this specification from the OMG revision issues web page <https://issues.omg.org/issues/lists/sti-fff>.

The FTF Recommendation and Report for this specification will be published in December 2022. If you are reading this after that date, please download the available specification from the OMG Specifications Catalog.

Formatted: Left

Copyright © 2020-2022, National Aeronautics and Space Administration
Copyright © 2020-2021-2022, Object Management Group

USE OF SPECIFICATION - TERMS, CONDITIONS & NOTICES

The material in this document details an Object Management Group specification in accordance with the terms, conditions and notices set forth below. This document does not represent a commitment to implement any portion of this specification in any company's products. The information contained in this document is subject to change without notice.

LICENSES

The companies listed above have granted to the Object Management Group, Inc. (OMG) a nonexclusive, royalty-free, paid up, worldwide license to copy and distribute this document and to modify this document and distribute copies of the modified version. Each of the copyright holders listed above has agreed that no person shall be deemed to have infringed the copyright in the included material of any such copyright holder by reason of having used the specification set forth herein or having conformed any computer software to the specification.

Subject to all of the terms and conditions below, the owners of the copyright in this specification hereby grant you a fully-paid up, non-exclusive, nontransferable, perpetual, worldwide license (without the right to sublicense), to use this specification to create and distribute software and special purpose specifications that are based upon this specification, and to use, copy, and distribute this specification as provided under the Copyright Act; provided that: (1) both the copyright notice identified above and this permission notice appear on any copies of this specification; (2) the use of the specifications is for informational purposes and will not be copied or posted on any network computer or broadcast in any media and will not be otherwise resold or transferred for commercial purposes; and (3) no modifications are made to this specification. This limited permission automatically terminates without notice if you breach any of these terms or conditions. Upon termination, you will destroy immediately any copies of the specifications in your possession or control.

PATENTS

The attention of adopters is directed to the possibility that compliance with or adoption of OMG specifications may require use of an invention covered by patent rights. OMG shall not be responsible for identifying patents for which a license may be required by any OMG specification, or for conducting legal inquiries into the legal validity or scope of those patents that are brought to its attention. OMG specifications are prospective and advisory only. Prospective users are responsible for protecting themselves against liability for infringement of patents.

GENERAL USE RESTRICTIONS

Any unauthorized use of this specification may violate copyright laws, trademark laws, and communications regulations and statutes. This document contains information which is protected by copyright. All Rights Reserved. No part of this work covered by copyright herein may be reproduced or used in any form or by any means--graphic, electronic, or mechanical, including photocopying, recording, taping, or information storage and retrieval systems--without permission of the copyright owner.

DISCLAIMER OF WARRANTY

WHILE THIS PUBLICATION IS BELIEVED TO BE ACCURATE, IT IS PROVIDED "AS IS" AND MAY CONTAIN ERRORS OR MISPRINTS. THE OBJECT MANAGEMENT GROUP AND THE COMPANIES LISTED ABOVE MAKE NO WARRANTY OF ANY KIND, EXPRESS OR IMPLIED, WITH REGARD TO THIS PUBLICATION, INCLUDING BUT NOT LIMITED TO ANY WARRANTY OF TITLE OR OWNERSHIP, IMPLIED WARRANTY OF MERCHANTABILITY OR WARRANTY OF FITNESS FOR A PARTICULAR PURPOSE OR USE. IN NO EVENT SHALL THE OBJECT MANAGEMENT GROUP OR ANY OF THE COMPANIES LISTED ABOVE BE LIABLE FOR ERRORS CONTAINED HEREIN OR FOR DIRECT, INDIRECT, INCIDENTAL, SPECIAL, CONSEQUENTIAL, RELIANCE OR COVER DAMAGES, INCLUDING LOSS OF PROFITS, REVENUE, DATA OR USE, INCURRED BY ANY USER OR ANY THIRD PARTY IN CONNECTION WITH THE FURNISHING, PERFORMANCE, OR USE OF THIS MATERIAL, EVEN IF ADVISED OF THE POSSIBILITY OF SUCH DAMAGES.

The entire risk as to the quality and performance of software developed using this specification is borne by you. This disclaimer of warranty constitutes an essential part of the license granted to you to use this specification.

RESTRICTED RIGHTS LEGEND

Use, duplication or disclosure by the U.S. Government is subject to the restrictions set forth in subparagraph (c) (1) (ii) of The Rights in Technical Data and Computer Software Clause at DFARS 252.227-7013 or in subparagraph (c)(1) and (2) of the Commercial Computer Software - Restricted Rights clauses at 48 C.F.R. 52.227-19 or as specified in 48 C.F.R. 227-7202-2 of the DoD F.A.R. Supplement and its successors, or as specified in 48 C.F.R. 12.212 of the Federal Acquisition Regulations and its successors, as applicable. The specification copyright owners are as indicated above and may be contacted through the Object Management Group, [Needham9C Medway Road, PMB 274, Milford, MA 02494](mailto:Needham9C@omg.com) or [1757109 Highland Avenue, Needham, MA 02494](mailto:1757109@omg.com), U.S.A.

TRADEMARKS

CORBA®, CORBA logos®, FIBO®, Financial Industry Business Ontology®, FINANCIAL INSTRUMENT GLOBAL IDENTIFIER®, IIOP®, IMM®, Model Driven Architecture®, MDA®, Object Management Group®, OMG®, OMG Logo®, SoaML®, SOAML®, SysML®, UAF®, Unified Modeling Language®, UML®, UML Cube Logo®, VSIPL®, and XMI® are registered trademarks of the Object Management Group, Inc.

For a complete list of trademarks, see: https://www.omg.org/legal/tm_list.htm. All other products or company names mentioned are used for identification purposes only and may be trademarks of their respective owners.

COMPLIANCE

The copyright holders listed above acknowledge that the Object Management Group (acting itself or through its designees) is and shall at all times be the sole entity that may authorize developers, suppliers and sellers of computer software to use certification marks, trademarks or other special designations to indicate compliance with these materials.

Software developed under the terms of this license may claim compliance or conformance with this specification if and only if the software compliance is of a nature fully matching the applicable compliance points as stated in the specification. Software developed only partially matching the applicable compliance points may claim only that the software was based on this specification but may not claim compliance or conformance with this specification. In the event that testing suites are implemented or approved by Object Management Group, Inc., software developed using this specification may claim compliance or conformance with the specification only if the software satisfactorily completes the testing suites.

OMG's Issue Reporting Procedure

All OMG specifications are subject to continuous review and improvement. As part of this process we encourage readers to report any ambiguities, inconsistencies, or inaccuracies they may find by completing the Issue Reporting Form listed on the main web page <https://www.omg.org>, under Documents, Report a Bug/Issue.

Table of Contents

1. Scope.....	25
2. Conformance.....	25
3. References.....	25
3.1 Normative References	25
3.2 Non-normative References	26
4. Terms and Definitions.....	27
5. Symbols.....	29
6. Additional Information	32
6.1 Acknowledgments	32
6.2 Notation Clause	32
7. Goals and Objectives	33
7.1 Overview	33
7.2 Purpose	33
7.3 Key Architecture Requirements	33
7.4 Fundamental Design	34
7.5 Roles and Responsibilities.....	35
8. Hardware Architecture.....	38
8.1 Generalized Hardware Architecture	38
8.1.1 Components	39
8.1.2 Functions.....	40
8.1.3 External Interfaces	41
8.1.4 Networking Interface	42
8.1.5 Internal Interfaces	42
8.2 Module Specification.....	43
8.2.1 General-Purpose Processing Module.....	43
8.2.2 Signal Processing Module.....	45
8.2.3 Radio Frequency Module.....	48
8.2.4 Security Module.....	49
8.2.5 Networking Module	49
8.2.6 Optical Module	50
8.2.7 Cognitive Module	50
8.3 Hardware Interface Description.....	50
8.3.1 Control and Data Interface.....	51
8.3.2 Operating Power Interface	52

8.3.3	Thermal Interface and Power Consumption	52
9.	Application Architecture.....	53
9.1	Configurable Hardware Design	53
9.2	Specialized Hardware Interfaces	54
10.	Software Architecture	55
10.1	Software Layer Model	55
10.2	Infrastructure	60
10.3	API Overview	60
10.3.1	Interface Structure.....	61
10.3.2	Implementation	62
10.4	Data Types and Predefined Values.....	62
10.4.1	Data Types	62
10.4.2	Predefined Values	63
10.5	Application and Device Control Interface	63
10.5.1	Infrastructure-Provided Instance Interface	63
10.5.2	Application-Provided Application Control Interfaces	64
10.5.3	Data Transfer Interface	66
10.5.4	Device-Provided Device Control Interface.....	67
10.6	STI API.....	67
10.6.1	General Utility API.....	68
10.6.2	Application Control API.....	69
10.6.3	Device Control API.....	72
10.6.4	Data Transfer API.....	73
10.6.5	Log API.....	73
10.6.6	File API.....	73
10.6.7	Messaging API.....	74
10.6.8	Time API.....	75
10.6.9	Clock Control API	77
10.7	Non-STI Software Interfaces.....	78
10.7.1	Operating System Interface.....	78
11.	External Command and Telemetry Interfaces	81
12.	Normative Requirements	83
12.1	Hardware	83
12.1.1	Provide GPM	83
12.1.2	Diagnostic Information Availability	83
12.1.3	Document RF.....	83
12.1.4	Document Power-Up State	83

Formatted: Default Paragraph Font, Font: 10.5 pt, Font color: Auto, Pattern: Clear

12.1.5	Document Hardware Capability	83
12.1.6	Document Hardware Limitations.....	84
12.1.7	Document Interfaces	84
12.1.8	Document the Control and Data Mechanisms	84
12.1.9	Document Power Supply	84
12.1.10	Document Thermal and Power Limits	84
12.1.11	Controllable From OE.....	84
12.2	Configurable Hardware Design.....	84
12.2.1	Platform Specific Wrapper	84
12.2.2	Document FPGA Interfaces.....	84
12.3	Software.....	85
12.3.1	Document System Library Interfaces Provided.....	85
12.3.2	Document System Library Interfaces Used	85
12.3.3	Document Language Interfaces Provided.....	85
12.3.4	STI Infrastructure Uses APP API	85
12.3.5	Use Language Specific Facilities Specified in Annex A.....	85
12.3.6	Use Language Specific Inheritance	85
12.3.7	Document STI Interfaces	85
12.3.8	Document Application's System Library Interfaces.....	85
12.4	STI Infrastructure-Provided Software	85
12.4.1	STI Infrastructure-Provided Data Types.....	85
12.4.2	Application based on Instance Object.....	87
12.4.3	STI Infrastructure-Provided Access Values.....	87
12.4.4	STI Infrastructure-Provided CalendarKind Values	88
12.4.5	STI Infrastructure-Provided HandleID Values	89
12.4.6	STI Infrastructure-Provided Result Values.....	89
12.4.7	STI Infrastructure-Provided Handle Name Values.....	90
12.4.8	STI Infrastructure-Provided Property Name Values.....	90
12.4.9	STI Infrastructure-Provided Size Limit Values	91
12.4.10	STI Infrastructure-Provided TimeWarp Values	92
12.4.11	STI Infrastructure-Provided CalendarValueCivil Structure.....	92
12.4.12	STI Infrastructure-Provided CalendarValueGPS Structure	93
12.4.13	STI Infrastructure-Provided CalendarValueDayNumber Structure.....	94
12.4.14	STI Infrastructure-Provided CalendarTime Union	94
12.5	STI Application-Provided Methods.....	94

Formatted: Default Paragraph Font, Font: 10.5 pt, Font color: Auto, Pattern: Clear

<u>12.5.1</u>	<u>STI Infrastructure-Provided APP GetHandleID Method.....</u>	<u>94</u>
<u>12.5.2</u>	<u>STI Infrastructure-Provided APP GetHandleName Method</u>	<u>95</u>
<u>12.5.3</u>	<u>STI Application-Provided APP Instance Method.....</u>	<u>96</u>
<u>12.5.4</u>	<u>STI Application-Provided APP Destroy Method</u>	<u>96</u>
<u>12.5.5</u>	<u>STI Application-Provided APP Initialize Method.....</u>	<u>97</u>
<u>12.5.6</u>	<u>STI Application-Provided APP ReleaseObject Method.....</u>	<u>97</u>
<u>12.5.7</u>	<u>STI Application-Provided APP Query Method.....</u>	<u>98</u>
<u>12.5.8</u>	<u>STI Application-Provided APP Configure Method.....</u>	<u>99</u>
<u>12.5.9</u>	<u>STI Application-Provided APP RunTest Method.....</u>	<u>100</u>
<u>12.5.10</u>	<u>STI Application-Provided APP Start Method.....</u>	<u>100</u>
<u>12.5.11</u>	<u>STI Application-Provided APP Stop Method.....</u>	<u>101</u>
<u>12.5.12</u>	<u>STI Application-Provided APP Read Method</u>	<u>101</u>
<u>12.5.13</u>	<u>STI Application-Provided APP Write Method</u>	<u>102</u>
<u>12.5.14</u>	<u>STI Application-Provided APP AddressRead Method</u>	<u>103</u>
<u>12.5.15</u>	<u>STI Application-Provided APP AddressWrite Method</u>	<u>103</u>
<u>12.6</u>	<u>STI Device-Provided Methods</u>	<u>104</u>
<u>12.6.1</u>	<u>STI Device-Provided DEV Open Method</u>	<u>104</u>
<u>12.6.2</u>	<u>STI Device-Provided DEV Load Method.....</u>	<u>105</u>
<u>12.6.3</u>	<u>STI Device-Provided DEV Reset Method.....</u>	<u>105</u>
<u>12.6.4</u>	<u>STI Device-Provided DEV Flush Method.....</u>	<u>106</u>
<u>12.6.5</u>	<u>STI Device-Provided DEV Unload Method</u>	<u>106</u>
<u>12.6.6</u>	<u>STI Device-Provided DEV Close Method.....</u>	<u>107</u>
<u>12.7</u>	<u>STI Infrastructure-Provided Methods.....</u>	<u>111</u>
<u>12.7.1</u>	<u>STI Infrastructure-Provided IsOK Method</u>	<u>111</u>
<u>12.7.2</u>	<u>STI Infrastructure-Provided ValidateHandleID Method</u>	<u>112</u>
<u>12.7.3</u>	<u>STI Infrastructure-Provided ValidateSize Method</u>	<u>112</u>
<u>12.7.4</u>	<u>STI Infrastructure-Provided InstantiateApp Method</u>	<u>113</u>
<u>12.7.5</u>	<u>STI Infrastructure-Provided GetErrorQueue Method.....</u>	<u>113</u>
<u>12.7.6</u>	<u>STI Infrastructure-Provided GetHandleName Method.....</u>	<u>114</u>
<u>12.7.7</u>	<u>STI Infrastructure-Provided HandleRequest Method</u>	<u>115</u>
<u>12.7.8</u>	<u>STI Infrastructure-Provided AbortApp Method</u>	<u>115</u>
<u>12.7.9</u>	<u>STI Infrastructure-Provided Initialize Method</u>	<u>116</u>
<u>12.7.10</u>	<u>STI Infrastructure-Provided ReleaseObject Method.....</u>	<u>116</u>
<u>12.7.11</u>	<u>STI Infrastructure-Provided Configure Method.....</u>	<u>117</u>

Formatted: Default Paragraph Font, Font: 10.5 pt, Font color: Auto, Pattern: Clear

12.7.12	STI Infrastructure-Provided Query Method	117
12.7.13	STI Infrastructure-Provided RunTest Method	118
12.7.14	STI Infrastructure-Provided Start Method	118
12.7.15	STI Infrastructure-Provided Stop Method	119
12.7.16	STI Infrastructure-Provided DeviceOpen Method	119
12.7.17	STI Infrastructure-Provided DeviceLoad Method	120
12.7.18	STI Infrastructure-Provided DeviceReset Method	121
12.7.19	STI Infrastructure-Provided DeviceFlush Method	121
12.7.20	STI Infrastructure-Provided DeviceUnload Method	122
12.7.21	STI Infrastructure-Provided DeviceClose Method	122
12.7.22	STI Infrastructure-Provided Read Method	123
12.7.23	STI Infrastructure-Provided Write Method	123
12.7.24	STI Infrastructure-Provided AddressRead Method	124
12.7.25	STI Infrastructure-Provided AddressWrite Method	125
12.7.26	STI Infrastructure-Provided Log Method	126
12.7.27	STI Infrastructure-Provided FileOpen Method	126
12.7.28	STI Infrastructure-Provided FileClose Method	127
12.7.29	STI Infrastructure-Provided FileGetSize Method	128
12.7.30	STI Infrastructure-Provided FileRemove Method	128
12.7.31	STI Infrastructure-Provided FileRename Method	129
12.7.32	STI Infrastructure-Provided FileGetFreeSpace Method	129
12.7.33	STI Infrastructure-Provided MessageQueueCreate Method	130
12.7.34	STI Infrastructure-Provided MessageQueueDelete Method	130
12.7.35	STI Infrastructure-Provided PubSubCreate Method	131
12.7.36	STI Infrastructure-Provided PubSubDelete Method	132
12.7.37	STI Infrastructure-Provided Register Method	132
12.7.38	STI Infrastructure-Provided Unregister Method	133
12.7.39	STI Infrastructure-Provided GetNanoseconds Method	133
12.7.40	STI Infrastructure-Provided GetSeconds Method	134
12.7.41	STI Infrastructure-Provided GetTimeWarp Method	134
12.7.42	STI Infrastructure-Provided TimeAdd Method	135
12.7.43	STI Infrastructure-Provided TimeSubtract Method	135
12.7.44	STI Infrastructure-Provided GetTime Method	136
12.7.45	STI Infrastructure-Provided SetTime Method	136

Formatted: Default Paragraph Font, Font: 10.5 pt, Font color: Auto, Pattern: Clear

12.7.46	STI Infrastructure-Provided GetCalendarTime Method	137
12.7.47	STI Infrastructure-Provided SetTimeAdjust Method.....	140
12.7.48	STI Infrastructure-Provided GetTimeAdjust Method.....	141
12.7.49	STI Infrastructure-Provided TimeSynch Method	141
12.7.50	STI Infrastructure-Provided Sleep Method	143
12.7.51	STI Infrastructure-Provided DelayUntil Method	144
12.7.52	STI Infrastructure-Provided ConvertToTimeWarp Method	144
12.8	External Command and Telemetry.....	145
12.8.1	Respond to External Commands.....	145
12.8.2	External Commands Use STI API.....	145
12.8.3	Document External Commands	145
12.8.4	Use STI Query for External Data.....	145
12.9	Clock Control Interface	146
12.9.1	STI Infrastructure-Provided CLK GetTime Method	146
12.9.2	STI Infrastructure-Provided CLK SetTime Method	146
12.9.3	STI Infrastructure-Provided CLK SetTimeAdjust Method	147
12.9.4	STI Infrastructure-Provided CLK GetTimeAdjust Method.....	147
12.9.5	STI Infrastructure-Provided CLK Sleep Method.....	148
12.9.6	STI Infrastructure-Provided CLK DelayUntil Method.....	148
0	Submission Specific Material.....	12
0.1	Submission Preface.....	12
0.2	Copyright Waiver	12
0.3	Submitter Representative.....	12
0.4	Author Team.....	12
0.5	Mapping to RFP Requirements	12
0.6	Responses to RFP Issues to Be Discussed.....	16
0.7	Proof of Concept.....	17
1	Scope.....	19
2	Conformance.....	19
3	References	19
3.1	Normative References	19
3.2	Non normative References	20
4	Terms and Definitions.....	21
5	Symbols.....	23
6	Additional Information	26
6.1	Acknowledgments	26
7	Goals and Objectives	26

- Formatted: Default Paragraph Font
- Formatted: Default Paragraph Font
- Formatted: Default Paragraph Font
- Formatted: Default Paragraph Font
- Formatted: Default Paragraph Font
- Formatted: Default Paragraph Font
- Formatted: Default Paragraph Font
- Formatted: Default Paragraph Font
- Formatted: Default Paragraph Font
- Formatted: Default Paragraph Font
- Formatted: Default Paragraph Font
- Formatted: Default Paragraph Font
- Formatted: Default Paragraph Font
- Formatted: Default Paragraph Font
- Formatted: Default Paragraph Font
- Formatted: Default Paragraph Font
- Formatted: Default Paragraph Font
- Formatted: Default Paragraph Font, Font: 10.5 pt, Font color: Auto, Pattern: Clear

7.1	Overview	26
7.2	Purpose	26
7.3	Key Architecture Requirements	27
7.4	Fundamental Design	28
7.5	Roles and Responsibilities	28
8	Hardware Architecture	30
8.1	Generalized Hardware Architecture	30
8.1.1	Components	31
8.1.2	Functions	32
8.1.3	External Interfaces	33
8.1.4	Networking Interface	34
8.1.5	Internal Interfaces	34
8.2	Module Specification	35
8.2.1	General Purpose Processing Module	35
8.2.2	Signal Processing Module	37
8.2.3	Radio Frequency Module	40
8.2.4	Security Module	41
8.2.5	Networking Module	41
8.2.6	Optical Module	42
8.2.7	Cognitive Module	42
8.3	Hardware Interface Description	42
8.3.1	Control and Data Interface	43
8.3.2	Operating Power Interface	44
8.3.3	Thermal Interface and Power Consumption	44
9	Application Architecture	45
9.1	Configurable Hardware Design	45
9.2	Specialized Hardware Interfaces	46
10	Software Architecture	46
10.1	Software Layer Model	47
10.2	Infrastructure	50
10.3	API Overview	51
10.3.1	Interface Structure	52
10.3.2	Implementation	53
10.4	Data Types and Constants	53
10.4.1	Data Types	53
10.4.2	Constants	54
10.5	Application and Device Control Interface	54
10.5.1	Infrastructure Provided Component Identifier Interface	54

Formatted	...
Formatted	...
Formatted	...
Formatted	...
Formatted	...
Formatted	...
Formatted	...
Formatted	...
Formatted	...
Formatted	...
Formatted	...
Formatted	...
Formatted	...
Formatted	...
Formatted	...
Formatted	...
Formatted	...
Formatted	...
Formatted	...
Formatted	...
Formatted	...
Formatted	...
Formatted	...
Formatted	...
Formatted	...
Formatted	...
Formatted	...
Formatted	...
Formatted	...
Formatted	...
Formatted	...
Formatted	...
Formatted	...
Formatted	...
Formatted	...
Formatted	...
Formatted	...
Formatted	...
Formatted	...
Formatted	...

- 10.5.2 Application Provided Application Control Interfaces 54
- 10.5.3 Device Provided Device Control Interface 56
- 10.5.4 Data Transfer Interface 57
- 10.6 STI API 58
 - 10.6.1 General Utility API 58
 - 10.6.2 Application Control API 59
 - 10.6.3 Device Control API 62
 - 10.6.4 Data Transfer API 63
 - 10.6.5 Log API 64
 - 10.6.6 File API 64
 - 10.6.7 Messaging API 65
 - 10.6.8 Time API 66
- 10.7 Non STI Software Interfaces 68
 - 10.7.1 Operating System Interface 69
- 11 External Command and Telemetry Interfaces 71
- 12 Normative Requirements 73
 - Hardware 73
 - 12.1 Provide GPM 73
 - 12.2 Diagnostic Information Availability 73
 - 12.3 Document RF 73
 - 12.4 Document Power Up State 73
 - 12.5 Document Hardware Capability 73
 - 12.6 Document Hardware Limitations 73
 - 12.7 Document Interfaces 74
 - 12.8 Document the Control and Data Mechanisms 74
 - 12.9 Document Power Supply 74
 - 12.10 Document Thermal and Power Limits 74
 - 12.11 Controllable From OE 74
 - Configurable Hardware Design 74
 - 12.12 Platform Specific Wrapper 74
 - 12.13 Document FPGA Interfaces 74
 - Software 75
 - 12.14 Document System Library Interfaces Provided 75
 - 12.15 Document System Library Interfaces Used 75
 - 12.16 Document Language Interfaces Provided 75
 - 12.17 STI Infrastructure Uses APP API 75
 - 12.18 Use Language Specific Facilities Specified in Annex A 75
 - 12.19 Use Language Specific Inheritance 75
 - 12.20 STI Infrastructure Provided Data Types 75
 - 12.21 Application based on Instance Object 77
 - 12.22 STI Infrastructure Provided Access Constants 77

Formatted	...
Formatted	...
Formatted	...
Formatted	...
Formatted	...
Formatted	...
Formatted	...
Formatted	...
Formatted	...
Formatted	...
Formatted	...
Formatted	...
Formatted	...
Formatted	...
Formatted	...
Formatted	...
Formatted	...
Formatted	...
Formatted	...
Formatted	...
Formatted	...
Formatted	...
Formatted	...
Formatted	...
Formatted	...
Formatted	...
Formatted	...
Formatted	...
Formatted	...
Formatted	...
Formatted	...
Formatted	...
Formatted	...
Formatted	...
Formatted	...
Formatted	...
Formatted	...
Formatted	...
Formatted	...
Formatted	...
Formatted	...

12.23	STI Infrastructure Provided CalendarKind Constants	77
12.24	STI Infrastructure Provided HandleID Constants	78
12.25	STI Infrastructure Provided Result Constants	79
12.26	STI Infrastructure Provided Handle Name Constants	79
12.27	STI Infrastructure Provided Property Name Constants	80
12.28	STI Infrastructure Provided Size Limit Constants	80
12.29	STI Infrastructure Provided TimeWarp Constants	81
12.30	STI Infrastructure Provided APP_GetHandleID Method	81
12.31	STI Infrastructure Provided APP_GetHandleName Method	82
12.32	STI Application Provided APP_Instance Method	82
12.33	STI Application Provided APP_Destroy Method	83
12.34	STI Application Provided APP_Initialize Method	83
12.35	STI Application Provided APP_ReleaseObject Method	84
12.36	STI Application Provided APP_Query Method	84
12.37	STI Application Provided APP_Configure Method	85
12.38	STI Application Provided APP_RunTest Method	86
12.39	STI Application Provided APP_Start Method	86
12.40	STI Application Provided APP_Stop Method	87
12.41	STI Device Provided DEV_Open Method	87
12.42	STI Device Provided DEV_Load Method	88
12.43	STI Device Provided DEV_Reset Method	88
12.44	STI Device Provided DEV_Flush Method	89
12.45	STI Device Provided DEV_Unload Method	89
12.46	STI Device Provided DEV_Close Method	90
12.47	STI Application Provided APP_Read Method	90
12.48	STI Application Provided APP_Write Method	91
12.49	STI Application Provided APP_AddressRead Method	92
12.50	STI Application Provided APP_AddressWrite Method	93
12.51	STI Infrastructure Provided IsOK Method	94
12.52	STI Infrastructure Provided ValidateHandleID Method	94
12.53	STI Infrastructure Provided ValidateSize Method	95
12.54	STI Infrastructure Provided InstantiateApp Method	95
12.55	STI Infrastructure Provided GetErrorQueue Method	96
12.56	STI Infrastructure Provided GetHandleName Method	96
12.57	STI Infrastructure Provided HandleRequest Method	97
12.58	STI Infrastructure Provided AbortApp Method	97
12.59	STI Infrastructure Provided Initialize Method	98
12.60	STI Infrastructure Provided ReleaseObject Method	98
12.61	STI Infrastructure Provided Configure Method	99
12.62	STI Infrastructure Provided Query Method	99
12.63	STI Infrastructure Provided RunTest Method	100
12.64	STI Infrastructure Provided Start Method	100
12.65	STI Infrastructure Provided Stop Method	101
12.66	STI Infrastructure Provided DeviceOpen Method	101
12.67	STI Infrastructure Provided DeviceLoad Method	102
12.68	STI Infrastructure Provided DeviceReset Method	102

Formatted ...

Formatted ...

Formatted ...

Formatted ...

Formatted ...

Formatted ...

Formatted ...

Formatted ...

Formatted ...

Formatted ...

Formatted ...

Formatted ...

Formatted ...

Formatted ...

Formatted ...

Formatted ...

Formatted ...

Formatted ...

Formatted ...

Formatted ...

Formatted ...

Formatted ...

Formatted ...

Formatted ...

Formatted ...

Formatted ...

Formatted ...

Formatted ...

Formatted ...

Formatted ...

Formatted ...

Formatted ...

Formatted ...

Formatted ...

Formatted ...

Formatted ...

Formatted ...

Formatted ...

Formatted ...

12.69	STI Infrastructure Provided DeviceFlush Method	103
12.70	STI Infrastructure Provided DeviceUnload Method	103
12.71	STI Infrastructure Provided DeviceClose Method	103
12.72	STI Infrastructure Provided Read Method	104
12.73	STI Infrastructure Provided Write Method	105
12.74	STI Infrastructure Provided AddressRead Method	105
12.75	STI Infrastructure Provided AddressWrite Method	106
12.76	STI Infrastructure Provided Log Method	107
12.77	STI Infrastructure Provided FileOpen Method	107
12.78	STI Infrastructure Provided FileClose Method	108
12.79	STI Infrastructure Provided FileGetSize Method	108
12.80	STI Infrastructure Provided FileRemove Method	109
12.81	STI Infrastructure Provided FileRename Method	109
12.82	STI Infrastructure Provided FileGetFreeSpace Method	110
12.83	STI Infrastructure Provided MessageQueueCreate Method	110
12.84	STI Infrastructure Provided MessageQueueDelete Method	111
12.85	STI Infrastructure Provided PubSubCreate Method	112
12.86	STI Infrastructure Provided PubSubDelete Method	112
12.87	STI Infrastructure Provided Register Method	113
12.88	STI Infrastructure Provided Unregister Method	113
12.89	STI Infrastructure Provided GetNanoseconds Method	114
12.90	STI Infrastructure Provided GetSeconds Method	114
12.91	STI Infrastructure Provided GetTimeWarp Method	114
12.92	STI Infrastructure Provided TimeAdd Method	115
12.93	STI Infrastructure Provided TimeSubtract Method	115
12.94	STI Infrastructure Provided GetTime Method	116
12.95	STI Infrastructure Provided SetTime Method	116
12.96	STI Infrastructure Provided GetCalendarTime Method	117
12.97	STI Infrastructure Provided CalendarValueCivil Structure	118
12.98	STI Infrastructure Provided CalendarValueGPS Structure	119
12.99	STI Infrastructure Provided CalendarValueDayNumber Structure	119
12.100	STI Infrastructure Provided CalendarTime Union	120
12.101	STI Infrastructure Provided SetTimeAdjust Method	120
12.102	STI Infrastructure Provided GetTimeAdjust Method	121
12.103	STI Infrastructure Provided TimeSynch Method	121
12.104	STI Infrastructure Provided Sleep Method	122
12.105	STI Infrastructure Provided DelayUntil Method	123
12.106	Document STI Interfaces	124
12.107	Document Application's System Library Interfaces	124
External Command and Telemetry		
12.108	Respond to External Commands	124
12.109	External Commands Use STI API	124
12.110	Document External Commands	124
12.111	Use STI Query for External Data	124

Annex A:	Language Translations	150
----------	-----------------------	-----

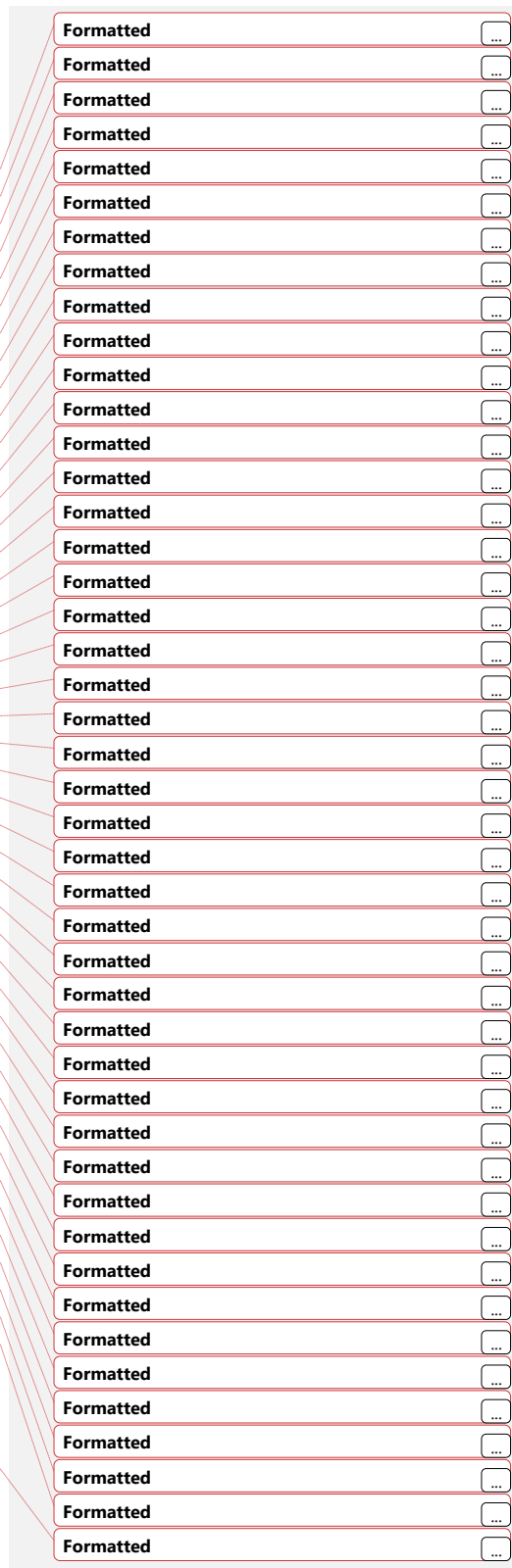

A.1	C Language Mapping	151
A.2	C++ Language Mapping	153
A.3	Python Mapping	155
A.4	Perl Mapping	157
A.5	Ruby Mapping	157
A.6	Java Mapping.....	158
A.7	Lua Mapping.....	158
Annex A:	Language Translations	125
A.1	C Language Mapping	126
A.2	C++ Language Mapping	128
A.3	Python Mapping	130
A.4	Perl Mapping	131
A.5	Ruby Mapping	132
A.6	Java Mapping.....	132
A.7	Lua Mapping.....	132

- Formatted: Default Paragraph Font
- Formatted: Default Paragraph Font
- Formatted: Default Paragraph Font
- Formatted: Default Paragraph Font
- Formatted: Default Paragraph Font
- Formatted: Default Paragraph Font
- Formatted: Default Paragraph Font

Formatted: Default Paragraph Font, Font: 10.5 pt, Font color: Auto, Pattern: Clear

Index of Tables

Table 1: Module Interface Characterization	51
Table 2: Example Operating Power Interface.....	52
Table 3: Software Component Descriptions	58
Table 4: Function Alternatives.....	81
Table 5: STI Variable Types.....	86
Table 6: Access Values.....	87
Table 7: CalendarKind Values.....	88
Table 8: HandleID Values	89
Table 9: Result Values	89
Table 10: Handle Name Values	90
Table 11: Property Name Values	90
Table 12: Size Limit Values	91
Table 13: TimeWarp Values.....	92
Table 4315: GetErrorQueue() Definition.....	113
Table 16: SetTimeAdjust() Definition	140
Table 17: GetTimeAdjust() Definition	141
Table 18: TimeSynch() Definition.....	141
Table 19: Sleep() Definition	143
Table 20: DelayUntil() Definition	144
Table 21: C Language Header Files.....	151
Table 22: C Language Data Type Mapping.....	152
Table 23: C++ Language Header Files	153
Table 24: C++ Language Data Type Mapping	154
Table 25: Python Language Data Type Mapping	156
Table 1: Module Interface Characterization	43
Table 2: Example Operating Power Interface.....	44
Table 3: Software Component Descriptions	49
Table 4: Function Alternatives.....	71
Table 5: STI Variable Types.....	75
Table 6: Access Constants	77
Table 7: CalendarKind Constants	77
Table 8: HandleID Constants	78
Table 9: Result Constants	79
Table 10: Handle Name Constants	79
Table 11: Property Name Constants	80
Table 12: Size Limit Constants	80
Table 13: TimeWarp Constants	81
Table 14: APP_GetHandleID() Definition	81
Table 15: APP_GetHandleName() Definition	82
Table 16: APP_Instance() Definition.....	82
Table 17: APP_Destroy() Definition	83
Table 18: APP_Initialize() Definition	83
Table 19: APP_ReleaseObject() Definition.....	84
Table 20: APP_Query() Definition	84

Formatted: Default Paragraph Font

Formatted: Default Paragraph Font

Formatted: Default Paragraph Font

Formatted: Default Paragraph Font

Formatted: Default Paragraph Font

Formatted: Default Paragraph Font

Formatted: Default Paragraph Font

Formatted: Default Paragraph Font

Formatted: Default Paragraph Font

Formatted: Default Paragraph Font

Formatted: Default Paragraph Font

Formatted: Default Paragraph Font

Formatted: Default Paragraph Font

Formatted: Default Paragraph Font

Formatted: Default Paragraph Font

Formatted: Default Paragraph Font

Formatted: Default Paragraph Font

Formatted: Default Paragraph Font

Formatted: Default Paragraph Font

Formatted: Default Paragraph Font

Formatted: Default Paragraph Font, Font: 10.5 pt, Font color: Auto, Pattern: Clear

Table 67: MessageQueueCreate() Definition	111
Table 68: MessageQueueDelete() Definition	111
Table 69: PubSubCreate() Definition	112
Table 70: PubSubDelete() Definition	112
Table 71: Register() Definition	113
Table 72: Unregister() Definition	113
Table 73: GetNanoseconds() Definition	114
Table 74: GetSeconds() Definition	114
Table 75: GetTimeWarp() Definition	114
Table 76: TimeAdd() Definition	115
Table 77: TimeSubtract() Definition	115
Table 78: GetTime() Definition	116
Table 79: SetTime() Definition	116
Table 80: GetCalendarTime() Definition	117
Table 81: CalendarValueCivil Structure Definition	118
Table 82: CalendarValueGPS Structure Definition	119
Table 83: CalendarValueDayNumber Structure Definition	119
Table 84: CalendarTime Union Definition	120
Table 85: SetTimeAdjust() Definition	120
Table 86: GetTimeAdjust() Definition	121
Table 87: TimeSynch() Definition	121
Table 88: Sleep() Definition	122
Table 89: DelayUntil() Definition	123
Table 90: C Language Header Files	126
Table 91: C Language Data Type Mapping	127
Table 92: C++ Language Header Files	128
Table 93: C++ Language Data Type Mapping	129
Table 94: Python Language Data Type Mapping	131

Formatted: Default Paragraph Font

Formatted: Default Paragraph Font

Formatted: Default Paragraph Font

Formatted: Default Paragraph Font

Formatted: Default Paragraph Font

Formatted: Default Paragraph Font

Formatted: Default Paragraph Font

Formatted: Default Paragraph Font

Formatted: Default Paragraph Font

Formatted: Default Paragraph Font

Formatted: Default Paragraph Font

Formatted: Default Paragraph Font

Formatted: Default Paragraph Font

Formatted: Default Paragraph Font

Formatted: Default Paragraph Font

Formatted: Default Paragraph Font

Formatted: Default Paragraph Font

Formatted: Default Paragraph Font

Formatted: Default Paragraph Font

Formatted: Default Paragraph Font

Formatted: Default Paragraph Font

Formatted: Default Paragraph Font

Formatted: Default Paragraph Font

Formatted: Default Paragraph Font

Formatted: Default Paragraph Font

Formatted: Default Paragraph Font

Formatted: Default Paragraph Font

Formatted: Default Paragraph Font

Formatted: Default Paragraph Font

Formatted: Default Paragraph Font, Font: 10.5 pt, Font color: Auto, Pattern: Clear

Table of Figures

Figure 1: Roles and Responsibilities.....	36
Figure 2: Notional STI Hardware Architecture	39
Figure 3: GPM Architecture Details (Detail of Figure 2).....	43
Figure 4: SPM Architecture Details (Detail of Figure 2).....	46
Figure 5: RFM Architecture Details (Detail of Figure 2).....	48
Figure 6: Software Execution Model.....	56
Figure 7: Layered Structure	57
Figure 8: Standards Conformance vs. Standards Compliance.....	59
Figure 9: Application and Device Structure	61
Figure 10: Sequence Diagram for Application Control Component	69
Figure 11: Sequence Diagram for InstantiateApp	70
Figure 12: Sequence Diagram for AbortApp.....	71
Figure 13: Sequence Diagram for Device Control Component.....	72
Figure 14: Calendar Time Value Representations	76
Figure 15: Profile Building Blocks	80
Figure 16: Command and Telemetry Interfaces	82
Figure 1: Roles and Responsibilities.....	29
Figure 2: Notional STI Hardware Architecture	31
Figure 3: GPM Architecture Details	35
Figure 4: SPM Architecture Details.....	38
Figure 5: RFM Architecture Details	40
Figure 6: Software Execution Model.....	47
Figure 7: Layered Structure	48
Figure 8: Standards Conformance vs. Standards Compliance.....	50
Figure 9: Application and Device Structure	52
Figure 10: Sequence Diagram for Application Control Component	60
Figure 11: Sequence Diagram for InstantiateApp	64
Figure 12: Sequence Diagram for AbortApp.....	64
Figure 13: Sequence Diagram for Device Control Component.....	65
Figure 14: Calendar Time Value Representations	67
Figure 15: Profile Building Blocks	70
Figure 16: Command and Telemetry Interfaces	72

- Formatted: Default Paragraph Font
- Formatted: Default Paragraph Font, (Asian) Chinese (China)
- Formatted: Default Paragraph Font, (Asian) Chinese (China)
- Formatted: Default Paragraph Font, (Asian) Chinese (China)
- Formatted: Default Paragraph Font, (Asian) Chinese (China)
- Formatted: Default Paragraph Font, (Asian) Chinese (China)
- Formatted: Default Paragraph Font, (Asian) Chinese (China), (Other) English (United States)
- Formatted: Default Paragraph Font, (Asian) Chinese (China)
- Formatted: Default Paragraph Font, (Asian) Chinese (China)
- Formatted: Default Paragraph Font, (Asian) Chinese (China)
- Formatted: Default Paragraph Font, (Asian) Chinese (China)
- Formatted: Default Paragraph Font, (Asian) Chinese (China)
- Formatted: Default Paragraph Font, (Asian) Chinese (China)
- Formatted: Default Paragraph Font, (Asian) Chinese (China)
- Formatted: Default Paragraph Font, (Asian) Chinese (China)
- Formatted: Default Paragraph Font, (Asian) Chinese (China)
- Formatted: Default Paragraph Font, Font: 10.5 pt, Font color: Auto, Pattern: Clear

Preface

OMG

Founded in 1989, the Object Management Group, Inc. (OMG) is an open membership, not-for-profit computer industry standards consortium that produces and maintains computer industry specifications for interoperable, portable, and reusable enterprise applications in distributed, heterogeneous environments. Membership includes Information Technology vendors, end users, government agencies, and academia.

OMG member companies write, adopt, and maintain its specifications following a mature, open process. OMG's specifications implement the Model Driven Architecture® (MDA®), maximizing ROI through a full-lifecycle approach to enterprise integration that covers multiple operating systems, programming languages, middleware and networking infrastructures, and software development environments. OMG's specifications include UML® (Unified Modeling Language™); CORBA® (Common Object Request Broker Architecture); CWM™ (Common Warehouse Metamodel); and industry-specific standards for dozens of vertical markets.

More information on the OMG is available at <https://www.omg.org>.

OMG Specifications

As noted, OMG specifications address middleware, modeling and vertical domain frameworks. All OMG Specifications are available from [the OMG website this URL at: https://www.omg.org/spec/](https://www.omg.org/spec/)

<https://www.omg.org/spec/>

All of OMG's formal specifications may be downloaded without charge from our website. (Products implementing OMG specifications are available from individual suppliers.) Copies of specifications, available in PostScript and PDF format, may be obtained from the Specifications Catalog cited above or by contacting the Object Management Group, Inc. at:

OMG Headquarters
9C Medway Road, PMB 274
Milford 109 Highland Avenue
Needham, MA 02494 01757
109 Highland Avenue
Needham, MA 02494
USA
Tel: +1-781-444-0404
Fax: +1-781-444-0320
Email: pubs@omg.org

Certain OMG specifications are also available as ISO/IEC standards. Please consult <https://www.iso.org/>

Typographical Conventions

The type styles shown below are used in this document to distinguish programming statements from ordinary English.

However, these conventions are not used in tables or section headings where no distinction is necessary.

- Formatted: Font: Italic
- Formatted: Body, Space Before: 7.9 pt, Line spacing: At least 5 pt, No widow/orphan control, Don't allow hanging punctuation, Don't adjust space between Latin and Asian text
- Formatted: Font: Times New Roman
- Formatted: Font: Times New Roman, 10 pt
- Formatted: Font: 10 pt
- Formatted: Font: 10 pt
- Formatted: Font: Times New Roman, 10 pt
- Formatted: Indent: Left: 0.02", Right: 0.03", Space After: 0.5 pt, Line spacing: Multiple 1.03 li, Allow hanging punctuation, Adjust space between Latin and Asian text, Tab stops: Not at -0.35" + 0.15" + 0.65" + 1.15" + 1.65" + 2.15" + 2.65" + 3.15" + 3.65" + 4.15" + 4.65"
- Formatted: Font: Times New Roman
- Formatted: Font: Times New Roman
- Formatted: Font: Times New Roman
- Formatted: Font: Times New Roman, 10 pt
- Formatted: Font: Times New Roman
- Formatted: Font: Times New Roman, 10 pt
- Formatted: Font: Times New Roman
- Formatted: Font: Times New Roman, 10 pt
- Formatted: Font: Times New Roman
- Formatted: Font: Times New Roman
- Formatted: Font: 10 pt, Italic
- Formatted: Font: Times New Roman, 10 pt
- Formatted: Font: 10 pt
- Formatted: Default Paragraph Font, Font: 10.5 pt, Font color: Auto, Pattern: Clear

Times/Times New Roman/Liberation Serif—10 pt.: Standard body text

Helvetica/Arial—10 pt. Bold: OMG Interface Definition Language (OMG IDL) and syntax elements.

Courier—10 pt. Bold: Programming language elements.

Helvetica/Arial—10 pt.: Exceptions

NOTE: Terms that appear in italics are defined in the glossary. Italic text also represents the name of a document, specification, or other publication.

Issues

The reader is encouraged to report any technical or editing issues/problems with this specification [via the report form at](#):

https://www.omg.org/report_issue.htm<https://issues.omg.org/issues/create-new-issue>

0—Submission-Specific Material

0.1—Submission Preface

This submission is in response to the Space Telecommunication Interface (STI) RFP, document number ~~mars/19-09-21~~.

The proposal describes an architecture for software-defined radios (SDRs) based on existing NASA standards. The proposed Space Telecommunication Interface (STI) provides a common, consistent framework to abstract the application software from the platform hardware to increase portability and reduce the cost and risk of using complex reconfigurable and reprogrammable radio interfaces across environments from Earth to outer space.

0.2—Copyright Waiver

The National Aeronautics and Space Administration grants to the Object Management Group, Inc. (OMG) a nonexclusive, royalty-free, paid-up, worldwide license to copy and distribute this document and to modify this document and distribute copies of the modified version.

0.3—Submitter Representative

Janette C. Briones, PhD.
Louis M. Handler
NASA Glenn Research Center, Cleveland, OH

Joseph P. Hickey
Vantage Partners, LLC, Brook Park, OH
William T. Dark
HX5, LLC

Jeffrey Smith, PhD.
Sierra Nevada Corporation, Herndon, VA

0.4—Author Team

Janette C. Briones, PhD.
Louis M. Handler
NASA Glenn Research Center, Cleveland, OH

Joseph P. Hickey
Vantage Partners, LLC, Brook Park, OH
William T. Dark
HX5, LLC

Jeffrey Smith, PhD.
Sierra Nevada Corporation, Herndon, VA

0.5—Mapping to RFP Requirements

This specification resolves the mandatory requirements as shown in Table 0.1.

Table 0.1: Mandatory RFP Requirements

Requirement	Description	How Is the Requirement Addressed
6.3.1	The Space PIM specification shall make maximum use of the SWRadio specification where applicable.	Not a consideration after the initial design was modified. Configure, Query, Start, Stop, and other method names are used.

Formatted: Default Paragraph Font, Font: 10.5 pt, Font color: Auto, Pattern: Clear

Requirement	Description	How Is the Requirement Addressed
6.5	Proposals shall 1) provide a PIM for data and interface definition (data and control planes including hardware abstractions) along with other requirements specific to each API such as which part of the SWRadio specification it could use as a foundation; 2) build off of the SWRadio specification and 3) provide a section specific to PSMs.	(1) Tables contain PIM/IDL methods (2) similar to SWRadio (3) with Annex A for PSM
6.5.1	Proposals shall reuse the UML Profile for SWRadio (PIM and PSM for SWRadio Components (SWR)) where appropriate to accommodate special space SDR constraints for communication equipment and physical layer facilities of the solicited PIM	Configure, Query, Start, Stop, and other method names are used. Because of our need in space for low weight and power (SWaP), a C language implementation was needed. The need for a C language implementation led to the elimination of exceptions and the replacement of object pointers with handle IDs in the calls where necessary.
6.5.1	Proposals shall specify a PIM and at least one normative PSM for Space SDR interfaces.	PIM and PSM both specified. PIM is specified throughout and PSM specified in Annex A.
6.5.1	This specification shall consist of at least two primary interface definitions, each with a control and data plane specification for interchanging configuration and run time data: 1) the STI Application Programming Interface (API) and 2) the STI Hardware Interface Definition (HID) API.	(1) API in 10.5 and 10.6, (2) HID in 8.2 and 8.3
6.5.1	The STI APIs shall provide an open software specification for the application engineer to develop STI waveform application programs.	When it is adopted and published by the OMG.
6.5.1	The STI response shall provide a space platform infrastructure to support waveform implementations. Additionally, the response to this RFP shall identify services required for waveform deployment and management.	10.6.2 Application Control API;
6.5.1	The STI proposal shall separate application and infrastructure APIs in its design.	10.5 vs 10.6
6.5.2	Proposals shall define compliance points to which COTS vendors must conform. The following is the minimum set of acceptable compliance points. Responses may include additional compliance points.	Section 12 is a summary.
6.5.2.1	Standard interfaces for control, management and status retrieval of the subsystems.	10.5.2 Application Provided Application Control Interfaces; 10.6.2 Application Control; 10.5.3 Device Provided Device Control Interface; 10.6.3 Device Control API

Formatted: Default Paragraph Font, Font: 10.5 pt, Font color: Auto, Pattern: Clear

Requirement	Description	How Is the Requirement Addressed
6.5.2.2	Control interfaces with functionality to control the synchronization of subsystems.	10.5.2 Application-Provided Application Control Interfaces; 10.6.2 Application Control; 10.5.3 Device-Provided Device Control Interface; 10.6.3 Device Control API
6.5.2.3	Interfaces that allow setting and querying parameters defined in the hardware abstraction of subsystem elements.	10.5.2 Application-Provided Application Control Interfaces; 10.6.2 Application Control; 10.5.3 Device-Provided Device Control Interface; 10.6.3 Device Control API
6.5.2.4	Application interfaces and related metadata defined separately for each subsystem.	10.5.2 Application-Provided Application Control Interfaces; 10.6.2 Application Control; 10.5.3 Device-Provided Device Control Interface; 10.6.3 Device Control API
6.5.3	Proposals shall specify the following networking aspects and functionality of Space Telecommunication Interfaces:	
6.5.3.1	Support different kinds of missions, such as legacy, new science, and new exploration.	Discusses optional capability.
6.5.3.2	Support IP routing and internet applications for space and ground elements.	Networking module in 8.1 and 8.2
6.5.3.3	Accommodate both scheduled and unscheduled communications.	Log, Query, PubSub, MessageQueues, Read, Write, AddressRead, AddressWrite
6.5.3.4	Accommodate both continuous and intermittent connectivity.	Allows either continuous or intermittent connectivity as programmed into the SDR.
6.5.3.5	Support space data links characterized by large and small signal propagation latencies; uni-directionality and bi-directionality; and both low and high bit error rates.	Doesn't specify a type of networking and allows Delay-Tolerant Networking (DTN), User Datagram Protocol (UDP), Transmission Control Protocol (TCP), or other protocols to be used.
6.5.3.6	Support data flows that: originate at arbitrary user locations on Earth and in space, terminate at arbitrary user locations or sets of user locations (i.e., multi-point delivery) on Earth and in space, and traverse N-hop transmission paths where $N > 1$.	No restriction as to the origin of the data flow as long as the data meets the appropriate security criteria.
6.5.3.7	Support transmission of the following types of data: command, telemetry, files (including web pages), messages (e.g., electronic mail), voice, video, and range safety.	Section 11 for External Command and Telemetry Interfaces; 10.6.6 for files; 10.6.7 for messaging; 10.6.3 and 10.6.4 for connection to hardware devices.
6.5.3.8	Provide the following qualities of data communication service (not necessarily in all combinations): isochrony, reliability, transmission order preservation, timeliness, and priority.	Digital to Analog (D2A) and Analog to Digital (A2D) are implied for SDR. Signal amplification, reliability, and packet transmission order preservation are not considered since this is not a performance or operations standard.
6.5.3.9	Provide data communication performance metrics and accountability.	STI encourages capture of performance metrics to allow cognitive improvement of functionality.

Formatted: Default Paragraph Font, Font: 10.5 pt, Font color: Auto, Pattern: Clear

Requirement	Description	How Is the Requirement Addressed
6.5.4	Proposals shall implement the following security aspects of the Space Telecommunication Interfaces:	
6.5.4.1	End-to-end protection of the authenticity of control information, specifically the ability to prevent unauthorized access to and alteration of data.	Non-conformant to STI RFP.
6.5.4.2	End-to-end protection of the confidentiality of sensitive control information, specifically the ability to prevent inappropriate disclosure of sensitive data.	Non-conformant to STI RFP.
6.5.4.3	Timely delivery of, and access to, critical control information with minimal delay caused by security services.	Non-conformant to STI RFP.
6.5.4.4	Bulk encryption for legacy assets.	Non-conformant to STI RFP.
6.5.4.5	The ability to manage and control security key material over the network using Federal Information Processing Standard (FIPS) approved key generation and distribution.	Non-conformant to STI RFP.
6.5.4.6	The ability to conduct Certification and Accreditation of the security service end-to-end system according to FIPS SP 800-37 [FIPS], using FIPS approved cryptographic modules and devices.	Non-conformant to STI RFP.

Table 0.2 lists the non-mandatory requirements in the RFP and how this submission addresses them.

Table 0.2: Non-Mandatory Requirements

Requirement	Description	How Is The Requirement Addressed
6.6.1	Design Requirements	
6.6.1.1	The ability to isolate waveform applications from hardware specific implementations.	Not always entirely possible but architecture allows isolating non hardware specific parts of waveform applications in software from hardware specific parts.
6.6.1.2	The ability of a radio to maintain reliable operation during remote software and firmware uploads.	Necessary but not part of STI.
6.6.1.3	The ability of a radio to control external hardware in real-time.	Documentation of HID, HAL, and Devices describe the use of application/resources.
6.6.1.4	The ability of a radio to operate legacy, current standard, and defined waveforms according to its hardware.	Allowed but not an STI requirement.
6.6.1.5	The ability of a radio to use both narrowband and wideband waveforms for voice, video, and data space communications.	Allowed but not an STI requirement.
6.6.1.6	The ability of a radio to use current, and be adaptable to new, networking protocols.	Allowed but not an STI requirement. See 7.3
6.6.1.7	The ability of a radio to maintain compatibility with current, and be adaptable to new, security measures.	Allowed but not an STI requirement.
6.6.1.8	Views/viewpoints used to express the deployment side of the previously described HID, and patterns,	Documentation of HID, HAL, and Devices describe the use of application/resources.

Formatted: Default Paragraph Font, Font: 10.5 pt, Font color: Auto, Pattern: Clear

Requirement	Description	How Is The Requirement Addressed
	e.g., application and resource factories to control application/resources, may be used to subdivide the STI profile for clarity and modularity.	
6.6.2	Interface Requirements	
6.6.3	Proposals may support the ability of a radio to use existing commercial off-the-shelf spacecraft interfaces.	Hardware is not specified by STI. Example is shown by STRS on 3 different radios by 3 different companies on SCaN Testbed on ISS.
6.6.3	Functional Requirements	
6.6.4.1	The ability of a radio to operate multiple waveforms simultaneously.	See 7.3
6.6.4.2	The ability of a radio to operate in several communication bands simultaneously.	See 7.3
6.6.4.3	The ability of a radio to operate multiple simultaneous channels in a single communication band.	See 7.3
6.6.4.4	The ability of a radio to autonomously monitor its communications environment and a) self adapt in order to optimize its communications link and b) report on or respond to remote interrogations regarding its health and configuration status.	See 7.3
6.6.4.5	The ability of a radio to be reconfigurable and to provide additional computing resources at times when communications are low or zero.	See 7.3
6.6.4.6	The ability of radio to detect extended loss of operation either due to signal degradation or internal malfunction.	See 7.3
6.6.4.7	The ability of a radio to autonomously recover from fault conditions after a reboot or power cycle event.	See 7.3
6.6.4.8	The ability of a radio to use current and be adaptable to new radiometric tracking and navigation waveforms and services.	Allowed but not an STI requirement.

0.6— Responses to RFP Issues to Be Discussed

Table 0.3 lists the Issues to Discussed in the RFP and how this submission addresses them.

Table 0.3: Issues to be Discussed

Issue	Description	How Is the Issue Discussed
6.7.1	Proposals shall discuss how legacy systems are supported by an implementation of this specification.	Waveform applications may be programmed to communicate with legacy systems.
6.7.2	Proposals shall discuss how it provides advantages for the space environment.	NASA's previous version, STRS, was used successfully on SCaN Testbed, 2012-2020. SWRP modified for SWaP and C-language interface.
6.7.3	Proposals shall discuss how the proposed specification handles external commands.	Section 11 External Command and Telemetry Interfaces
6.7.4	Proposals shall discuss how the proposed specification meets all stated requirements and associated rationale.	See rest of this matrix

Formatted: Default Paragraph Font, Font: 10.5 pt, Font color: Auto, Pattern: Clear

Issue	Description	How Is the Issue Discussed
6.7.5	Proposals shall discuss the rationale for not satisfying non-mandatory features.	The security aspects in 6.5.4 of the RFP were considered to be possible within this standard but were not standardized further.
6.7.6	Proposals shall discuss how interfaces from a HID to FPGAs and other signal processing specific based platforms are specified, e.g., reuse of existing hardware abstraction layers or new design to satisfy modern signal processing hardware.	STI response states that standards for API and documentation encourage reuse ability.
6.7.7	Proposals shall discuss metrics that determine quality of service elements, e.g., timeliness and reliability.	Metrics such as signal-to-noise ratio, visual, Doppler, and radar allow for cognitive, radio-metric tracking, navigation, and other services that are integrated with communication services. In addition, a heartbeat signal and watchdog timer aid in autonomous operation allowing rebooting as necessary.
6.7.8	Proposals shall discuss existing commercial off the shelf spacecraft interfaces that may be used to satisfy one or more requirements.	Generally, newer COTS components are not designed with the space radiation environment in mind, nor are they built to withstand the rigors of launch into space. However, certain hardware and firmware (e.g. using triple mode redundancy) have enough use in space that they may be considered COTS.

0.7 — Proof of Concept

The foundation of this proposal evolved from a National Aeronautics and Space Administration (NASA) project whose goal was to improve the portability of components utilized in software defined radio (SDR) deployments. The intent is to improve the return on investment in software development by allowing the related components to be deployed in more than one project/mission without incurring significant additional development time.

A predecessor to this STI specification was developed by NASA as part of a technology demonstration of software-defined radio technology. The use of SDRs for NASA missions was a new concept in 2002, made possible by the development of reconfigurable components suitable for use in space radios. A need to reduce the cost and risk of using SDRs was identified and the development of a common SDR architecture was initiated as a means to achieve this.

In 2007, the architecture was determined to be ready for flight implementation in a technology development project. This project was originally called the Communication, Navigation, and Networking reConfigurable Testbed (CoNNeCT), and later renamed the Space Communications and Navigation (SCaN) Testbed. Three SDRs were procured in 2008 and 2009 for the SCaN Testbed, using the architecture defined in a technical memorandum and referred to in the procurement specifications as Space Telecommunications Radio System version 1.02.1.

The SCaN Testbed was launched in July 2012 and operated on an external truss on the International Space Station (ISS). The SCaN Testbed was an experimental communications system that provided the capability for S-Band, Ka-Band, and L-Band communication with space and ground assets. Investigation of SDR technology and the STI architecture was the primary focus of the SCaN Testbed. As a completely reconfigurable testbed, the SCaN Testbed provided experimenters an opportunity to develop and demonstrate experimental waveforms and applications for communication, networking, and navigation concepts and to advance the understanding of operating SDRs in space.

Lessons learned from the SDR platform provider, application developers, and integrators of the SCaN Testbed provided critical insight for the development of future versions of the Space Telecommunications Radio System

Formatted: Default Paragraph Font, Font: 10.5 pt, Font color: Auto, Pattern: Clear

(STRS), which was released as NASA standard NASA-STD-4009. The most recent revision to the NASA standard, designated as NASA-STD-4009A, serves as the basis for this STI specification.

As part of this effort, NASA has developed a reference implementation of this architecture as a C/C++ library. Additionally, NASA has deployed several complete STRS operating environments on different radio platforms from different vendors and maintains a library of portable applications that are compliant with the architecture.

Formatted: Default Paragraph Font, Font: 10.5 pt, Font color: Auto, Pattern: Clear

1. Scope

This document, the Space Telecommunication Interface (STI), specifies the data types, application programming interface, and associated operational patterns that compliant software defined radio (SDR) platforms are required to implement. This is intended to promote portability of SDR applications between radio platform providers by providing a common programming interface.

In order to be adaptable to a wide variety of platforms and applications, this specification focuses on a metamodel for the hardware and software architecture of an SDR, rather than prescribing a specific implementation. As such, an adequate level of knowledge capture must be documented to facilitate portability and reuse of hardware and software architecture.

2. Conformance

In this document, conformance or compliance is used to indicate normative elements; that is, they are to be followed in order to comply with the specified requirements. Shall is used to indicate a requirement that is contractually binding, meaning it must be implemented, and its implementation verified. Will is used to indicate a statement of fact. Will statements are not subject to verification. Should is used to indicate a goal which must be addressed by the design team but is not formally verified.

The primary point of conformance is support of the given platform independent model (PIM) described in section ~~12. Normative Requirements, 12, Normative Requirements~~, in this document. This specification concerns multiple aspects of SDRs, with different specific points of conformance for each aspect. Hardware architecture conformance is indicated mainly through a hardware interface document (HID), which specifies how the PIM is realized in a given design. Software architecture conformance is based on the implementation and usage of the various software interfaces prescribed in this document. Ellipses (...) are used to indicate continuation or user-defined values, whether enclosed in braces or not. The platform specific model (PSM) language-specific requirements are indicated in Annex A. To summarize, section 12 and portions of Annex A that pertain to the language of implementation are normative.

3. References

3.1 Normative References

The following normative documents contain provisions which, through reference in this text, constitute provisions of this specification. For dated references, subsequent amendments to, or revisions of, any of these publications do not apply.

Object Management Group (OMG):

CPP	C++ Language Mapping Specification (https://www.omg.org/spec/CPP/)
DDS-JAVA	Java 5 Language PSM for DDS (https://www.omg.org/spec/DDS-Java)
IDL	Interface Definition Language Specification (https://www.omg.org/spec/IDL)
PYTH	Python Language Mapping Specification (https://www.omg.org/spec/PYTH)
SysML	Systems Modeling Language Specification (https://www.omg.org/spec/SysML/)
UML	Unified Modeling Language Specification (https://www.omg.org/spec/UML/)

Formatted: Default Paragraph Font, Font: 10.5 pt, Font color: Auto, Pattern: Clear

Institute of Electrical and Electronics Engineers (IEEE):

1003.13 IEEE Standard for Information Technology—Standardized Application Environment Profile (AEP)—POSIX® Realtime and Embedded Application Support (e.g. <https://standards.globalspec.com/std/896855/IEEE%201003.13>)

International Organization for Standardization (ISO):

8601 Data elements and interchange formats - Information interchange - Representation of Dates and Times (e.g. <https://www.iso.org/standard/70907.html>, <https://www.iso.org/standard/70908.html>)
9899 Information technology—Programming languages—C (e.g. <https://standards.globalspec.com/std/10395283/ISO/IEC%209899>)
9945 Information technology—Portable Operating System Interface (POSIX®) Base Specifications (e.g. <https://standards.globalspec.com/std/10153436/DS/ISO/IEC/IEEE%209945>)
14882 Information technology—Programming languages—C++ (e.g. <https://standards.globalspec.com/std/10194484/ISO/IEC%2014882>)
30170 Information technology — Programming languages — Ruby (e.g. <https://standards.globalspec.com/std/1518370/ISO/IEC%2030170>)

Other:

JAVA Java Language Specification (<https://docs.oracle.com/javase/specs/jls/se11/jls11.pdf>)
LUA Lua 5.3 Reference Manual (<https://www.lua.org/manual/5.3/>)
PERL Perl Language Specification (<https://perldoc.perl.org/>)
PYTHON Python Language Mapping Specification (<https://www.python.org/doc/>)

3.2 Non-normative References

The following documents provide additional guidelines, historical context or rationale for elements of this specification.

Object Management Group (OMG):

ORMSC/14-06-01 Model Driven Architecture (MDA) Guide (<https://www.omg.org/cgi-bin/doc?ormsc/14-06-01>)
SDRP/1.0 PIM and PSM for Software Radio Components Specification (SWRADIO) (formal/07-03-01) (<https://www.omg.org/spec/SDRP/>)

National Aeronautics and Space Administration (NASA):

NASA-STD-4009A Space Telecommunications Radio Systems (STRS) Architecture Standard (<https://standards.nasa.gov/standard/occe/nasa-std-4009>)
NASA-HDBK-4009A Space Telecommunications Radio Systems (STRS) Architecture Standard Rationale (<https://standards.nasa.gov/standard/occe/nasa-hdbk-4009>)
NASA/TM—2007-215042 Space Telecommunications Radio System (STRS) Architecture Goals/Objectives and Level 1 Requirements (<https://ntrs.nasa.gov/archive/nasa/casi.ntrs.nasa.gov/20080008862.pdf>)

Formatted: Default Paragraph Font, Font: 10.5 pt, Font color: Auto, Pattern: Clear

NASA/TP—2008-214813 Space Telecommunications Radio System Software Architecture Concepts and Analysis (<https://ntrs.nasa.gov/archive/nasa/casi.ntrs.nasa.gov/20080024190.pdf>)

United States Department of Defense:

MIL-STD-1553 Digital Time Division Command/Response Multiplex Data Bus (e.g. <https://www.milstd1553.com/>)

SCA Software Communications Architecture Specification, Version 2.2.2 (https://sds.wirelessinnovation.org/assets/sca_version_2_2_2.pdf)

4. Terms and Definitions

For the purposes of this specification, the following terms and definitions apply.

Adaptability

Adaptability is the ease with which a system satisfies differing system constraints and user needs.

Application Program Interface (API)

An application program interface (API) is a formalized set of software calls and routines that can be referenced by the application program in order to access supporting system or network services.

Board Support Package (BSP)

A board support package (BSP) provides the hardware abstraction of the GPM module for the POSIX-compliant Operating System. It contains the boot and the generic and processor specific drivers required for the specific hardware. The BSP leverages commercial off the shelf (COTS) device drivers and other software necessary for applications to access the specific hardware.

Component

A component represents a modular part of a system that encapsulates its contents and whose manifestation is replaceable within its environment. A component exposes a set of provided and required interfaces that specify the component behavior and operation.

Device

A hardware device is a physical entity that is capable of performing a function. A software device is a software abstraction of a hardware device(s). A STI device is a software device that is part of the STI Infrastructure having a well defined and portable API which may use the HAL to read, write, and control hardware devices.

External Interface

An external interface consists of software and/or hardware that enable signals to be transported to and/or from a radio. Examples include interfaces to/from the flight computer, power, data sources/sinks, and antenna.

Facility

The realization of certain functionality through a set of well-defined interfaces.

Fault Management

Fault management is the set of functions that detect, isolate, and correct malfunctions within the system or provide notifications.

General-purpose Processing Module (GPM)

Formatted: Default Paragraph Font, Font: 10.5 pt, Font color: Auto, Pattern: Clear

A general-purpose processing module (GPM) is a hardware module used for general purpose processing that contains the STI OE. The GPM consists of the general-purpose processor, appropriate memory both volatile and non-volatile, system bus, the spacecraft (or host) telemetry, tracking and command (TT&C) interface, ground support telemetry and test interface, and the components to support the radio configuration.

Hardware Abstraction Layer (HAL)

The hardware abstraction layer (HAL) is the library of functions that provides a platform independent view of the specialized hardware by abstracting the physical hardware interfaces. The HAL implements any software or firmware that is directly dependent on the underlying hardware. The HAL is the part of the operating environment (OE) that the STI Infrastructure uses to access hardware.

Hardware Interface Description (HID)

The hardware interface description (HID) describes physical and electrical interfaces, hardware performance, capability, capacity, size, weight, and power requirements.

Logical Device

A software component that is an abstraction of a hardware device it represents.

Mapping

The specification of a mechanism for transforming the elements of a model conforming to a particular metamodel into elements of another model that conforms to another (possibly the same) metamodel.

Metamodel

A model of models.

Model

A formal specification of the function, structure and/or behavior of an application or system.

Model Driven Architecture (MDA)

An approach to IT system specification that separates the specification of functionality from the specification of the implementation of that functionality on a specific technology platform.

Module

Module is a self-contained hardware or software component that interacts with a larger system. A software module (program module) performs specific tasks within a software system. A hardware module is a physical grouping of devices capable of implementing specific functions.

Platform

A set of subsystems or technologies that provide a coherent set of functionality through interfaces and specified usage patterns.

Platform Independent Model (PIM)

A model of a subsystem that contains no information specific to the platform, or the technology that is used to realize it.

Platform Specific Model (PSM)

A model of a subsystem that includes information about the specific technology that is used in the realization of it on a specific platform, and hence possibly contains elements that are specific to the platform.

Portability

Portability is the ease with which a system application or service can be transferred from one hardware or software environment to another.

Portable Operating System Interface (POSIX)

Formatted: Default Paragraph Font, Font: 10.5 pt, Font color: Auto, Pattern: Clear

Portable operating system interface (POSIX) refers to a family of IEEE standards 1003.n which describes the fundamental operating system services and functions necessary to provide a UNIX-like kernel interface to applications. POSIX is not an operating system but assures guaranteed programming interfaces available to the application programmer.

Radio Frequency (RF) Module (RFM)

The radio frequency module (RFM) performs the conversion to and from carrier frequencies and provides the signal processing module with baseband or IF signals and the transmission and reception equipment with RF signals. RFM associated components may include filters, RF switches, diplexers, low noise amplifiers (LNAs), power amplifiers, and analog to digital (and vice-versa) converters. This module handles the interfaces that control the final stage of transmission or first stage of reception of the wireless signals, including antennas.

Radio Platform

The Radio Platform is a platform that provides radio functionality.

Real-Time Operating System (RTOS)

Real-time operating system (RTOS) is an operating system that guarantees a certain capability within a specified time constraint.

Reconfigurable Transceiver (RT)

A reconfigurable transceiver (RT) is a radio with limited processing and selectable remote reconfiguration (e.g., filter parameters and modulations).

Service

A software program that provides functionality available for use by other applications.

Signal Processing Module (SPM)

The signal processing module (SPM) contains the implementations of the signal processing used to handle the transformation of received digitally-formatted signals into data packets and/or the conversion of data packets into digitally-formatted signals to be transmitted. Also included is the spacecraft data interface. Components include application specific integrated circuits (ASICs), field programmable gate arrays (FPGAs), digital signal processors (DSPs), memory, and connection fabric or bus.

Space Telecommunications Radio System (STRS)

Space telecommunications radio system (STRS) is the name of the project that defines and maintains the SDR architecture for NASA.

STI Infrastructure

The STI infrastructure is that part of the STI operating environment which configures and controls STI waveforms and services as well as specialized hardware via the HAL. Additional functionality may be required for radio robustness and mission dependent requirements.

STI Operating Environment (OE)

The STI operating environment (OE) is the portion of the STI radio that contains the STI Infrastructure, the POSIX conformant RTOS, the HAL, and optional middleware software.

STI Radio

A STI radio is a software defined radio compliant with the STI architecture standard, running one or more waveforms.

5. Symbols

The following acronyms and abbreviations are used in this document

Space Telecommunication Interface — [\(STI\), v1.0 -- beta 2](#)

28

Formatted: Default Paragraph Font, Font: 10.5 pt, Font color: Auto, Pattern: Clear

A	Ampere
A2D	Analog-to-Digital
ADC	Analog-to-Digital Converter
AEP	Application Environment Profile
AGC	Automatic Gain Control
ANSI	American National Standards Institute
API	Application Programming Interface
APP	Application
ASCII	American Standard Code for Information Interchange
ASIC	Application-Specific Integrated Circuit
BIT	Built-in Test
BSP	Board Support Package
C&DH	Command and Data Handling
CCSDS	Consultative Committee for Space Data Systems
COTS	Commercial Off the Shelf
D2A	Digital-to-Analog
DAC	Digital-to-Analog Converter
DEC	Digital Equipment Corporation
DLL	Dynamic Link Library
DSP	Digital Signal Processor
EDIF	Electronic Design Interchange Format
EEPROM	Electrically Erasable, Programmable Read-Only Memory
FFRDC	Federally Funded Research and Development Center
FIFO	First In, First Out
FIPS	Federal Information Processing Standard
FPGA	Field Programmable Gate Array
GPIO	General Purpose Input Output
GPM	General-purpose Processing Module
GPP	General Purpose Processor
GPS	Global Positioning System
HAL	Hardware Abstraction Layer
HDBK	Handbook
HDL	Hardware Description Language
HID	Hardware Interface Description
HW	Hardware
I/O	Input/Output
I ² C	Inter-Integrated Circuit
ID	Identification, Identifier
IDL	Interface Definition Language
IEC	International Electrotechnical Commission

IEEE	The Institute of Electrical and Electronics Engineers
IF	Intermediate Frequency
INCITS	Inter-National Committee for Information Technology Standards
IP	Internet Protocol
ISO	International Organization for Standardization
ISR	Interrupt Service Routine
LLC	Logical Link Control <u>or Limited Liability Company</u>
LNA	Low Noise Amplifier
MAC	Media Access Control
MARS	OMG's Middleware and Related Services
MDA	Model Driven Architecture
MIL	Military
MJD	Modified Julian Date
MMU	Memory Management Unit
NASA	National Aeronautics and Space Administration
NM	Network Module
NTP	Network time protocol
OAL	OEM adaptation layer
OE	Operating Environment
OEM	Original Equipment Manufacturer
OM	Optical Module
OMG	Object Management Group
ORMSC	Operational Research MSc Programmes
OS	Operating System
OSS	Open Source Software
PIM	Platform-Independent Model
PLD	Programmable Logic Device
POSIX®	Portable Operating System Interface
PROM	Programmable Read-Only Memory
RAM	Random Access Memory
RF	Radio Frequency
RFM	Radio Frequency Module
ROI	Return on Investment
ROM	Read-Only Memory
RTOS	Real-Time Operating System
SCA	Software Communications Architecture
SDR	Software-Defined Radio
SEC	Security Module
SEU	Single Event Upset
SNC TF	OMG's MARS Secure Network Communications task force

SPM	Signal Processing Module
SRAM	Static Random-Access Memory
STD	Standard
STI	Space Telecommunication Interface
SysML	Systems Modeling Language
TAI	International Atomic Time (temps atomique international)
TCP	Transmission Control Protocol
TMR	Triple-Mode Redundancy
TT&C	Telemetry, tracking, and command
UML	Unified Modeling Language
UTC	Coordinated Universal Time
V	Volt
V&V	Verification and Validation
VDD	Version Description Document
VHDL	VHSIC Hardware Description Language
VHSIC	Very High Speed Integrated Circuit
XML	Extensible Markup Language

6. Additional Information

6.1 Acknowledgments

The following companies contributed to the development of this specification:

- NASA Glenn Research Center
- Sierra Nevada Corporation
- Vantage Partners, LLC
- HX5, LLC

6.2 Notation Clause

Colors are provided for clarification purposes only and are non-normative.

Formatted: Font: 10 pt

Formatted: Text body (user), Adjust space between Asian text and numbers, Font Alignment: Auto

Formatted: Default Paragraph Font, Font: 10.5 pt, Font color: Auto, Pattern: Clear

7. Goals and Objectives

7.1 Overview

The goals and objectives of the Space Telecommunication Interface (STI) architecture for software-defined radios (SDRs) is to provide a common, consistent framework that abstracts the application software from the platform hardware to reduce the cost and risk of using complex reconfigurable and reprogrammable radio interfaces across different space and satellite projects. It achieves this objective by defining an architecture to enable the reuse of applications (waveforms and services implemented on the SDR) across heterogeneous SDR platforms and thereby reduces dependence on a single vendor or platform type.

The specification provides a detailed description and set of requirements to implement the architecture. The specification focuses on the key components and facilities by prescribing their functionality and interfaces for both the hardware and the software. The intended audience for this specification is composed of software and hardware developers who need architecture specification details to develop an STI platform or application.

7.2 Purpose

The purpose of this specification is to establish an open architecture specification for space and ground SDRs. Many space projects either use hardware radios, which cannot be modified once deployed, or software-defined radios with an architecture that depends on the radio provider and involves significant effort to add new applications.

This specification is intended to assist in the development of software-defined, reconfigurable technology to meet future space communications and navigation system needs. Software-based SDRs enable advanced operations that potentially reduce mission life-cycle costs for space or ground platforms. Since SDR technology allows radios to be reconfigured to perform different functions, it may reduce the number of discrete radio devices required to achieve desired objectives, which also decreases mass and power requirements for the overall system.

7.3 Key Architecture Requirements

The key goals in the development of the STI architecture are to decrease the development time, cost, and risk of using SDRs while still accommodating advances in technology. The advent of software-based applications allows minimal rework to reuse applications and to adapt to evolving requirements.

The requirements for the architecture are derived from the following STI goals and objectives:

- Usable across most space project types (scalability and flexibility).
- Decrease development time and cost.
- Increase reliability of SDRs.
- Accommodate advances in technology with minimal rework (extensibility).
- Adaptable to evolving requirements (adaptability).
- Leverage existing or developing standards, resources, and experience (state-of-the-art and state-of-practices).
- Maintain vendor independence.
- Enhance waveform application portability and re-usability.
- Interoperable with existing radios

Conversely, the architecture does **not** specify mission-specific functional and performance requirements such as:

- Any specific hardware
- Contents or format of the external interfaces to the SDR

- Waveform-specific requirements such as data rate, coding scheme, and modulation and demodulation techniques.
- Security, fault tolerance, redundancy, and fault mitigation approaches.

Instead, the architecture is careful to enable all solutions that the project might require as they relate to the mission-specific functional and performance specifications. The architecture does not preclude the implementation of mission-developed services on the SDR, including but not limited to:

- Multiple waveforms operating simultaneously across any RF band defined in the SDR specification.
- Commanded built-in-test (BIT) and status reporting.
- Real-time operational diagnostics.
- Automated system recovery and initialization.
- Networking and navigation within the SDR.
- Secure transmission.
- Shared processing among on-board elements.

To meet these goals and objectives, the STI architecture has an open architecture design that accommodates a varying range of radio form factors. Historically, users have experienced up to 98% software reuse. The architecture has allowed parallel and independent software and platform development as well as reduced dependence on a single SDR provider by separating application development from the hardware platform development. The architecture has also allowed the software to be modified late in development or after deployment for new requirements opportunities or to fix bugs. The architecture provides standardized interfaces for cognitive engine inclusions across different platforms.

7.4 Fundamental Design

This STI Standard consists of hardware, configurable hardware design, and software architectures with accompanying description, guidance, and requirements.

The terms “software” and “configurable hardware design” are used in this specification to distinguish the architecture items that apply to code (source code, object code, executables, etc.) implemented on a processor; and designs (hardware description language/HDL source, loadable files, data tables, etc.) implemented in a configurable hardware device such as a field programmable gate array (FPGA). Both items can change the functionality of the radio in-situ using program control. The term “software” is also used in a generic sense in this specification to discuss all configurable items of the radio, including configurable hardware design. The terminology used is not meant to imply design and implementation process.

The STI hardware architecture is specified at a facility level. The hardware architecture requirements are written so that the hardware provider defines the functional breakdown (modules or components) of the system and publishes the functions and interfaces for each module and for the entire platform in a hardware interface description (HID) document. This information enables others developing applications or additional modules, or interfacing to the platform, to have the knowledge to integrate and test the hardware interfaces and understand the features and limitations of the platform. This specification encourages the development of applications that are modular, portable, reconfigurable, and reusable.

The software architecture is the focus of this STI Standard. STI applications use the STI infrastructure-provided application program interfaces (APIs) and services to load, verify, execute, change parameters, terminate, or unload an application. The software architectural model describes the relationship between the software elements, defined in layers, in an STI-compliant radio. The model illustrates the different software elements used in the software execution and defines the API layers between an STI application and the Operational Environment (OE), and between the OE and the hardware platform.

The STI software layers are separated to enable developers to implement the software layers differently according to their requirements while still complying with the STI architecture. A key aspect is the abstraction of the STI application, which is either a waveform or service, from the underlying OE software to promote portability and

Formatted: Default Paragraph Font, Font: 10.5 pt, Font color: Auto, Pattern: Clear

reusability of the STI application. Interfaces in STI software architecture can be divided into three general categories, as follows:

- The STI APIs, defined in this document, and the application-specific data structures associated with these APIs.
- The operating system interface, such as POSIX®.
- The interface to external software modules, ~~libraries~~libraries, or dependencies, such as third-party signal processing software, mathematical toolkits, or an interface to any application-specific hardware.

The STI APIs provide the interfaces that allow applications to be instantiated and use platform services. These APIs also enable communication between STI applications and the STI infrastructure. The hardware abstraction layer (HAL) provides a software view of the specialized hardware by abstracting the physical hardware of interfaces. It is to be published so that software and configurable hardware design running on the platform's specialized hardware can integrate with the STI infrastructure.

7.5 Roles and Responsibilities

The final configuration of an SDR and its applications is generally a product of multiple organizations performing various tasks. The separation of requirements, responsibilities, and resulting tasks is assigned in this specification by logical role where each role has requirements that may be satisfied by an individual or delegated to a subordinate organization(s). As [figure 1](#), Roles and Responsibilities, illustrates, the effort begins with a mission need for a radio, which could support communications, navigation, and in some instances even networking functions. The mission system engineer defines radio interface requirements. For each mission, the system integrators, platform providers, and application developers are selected. Eventually, the platform and applications are integrated into the STI-compliant radio product. Both the hardware and software are tailored to meet mission-specific needs.

Commented [HLM(L1): [JIRA issue STI_5: Correct SysML in figures](#)

Formatted: Default Paragraph Font, Font: 10.5 pt, Font color: Auto, Pattern: Clear

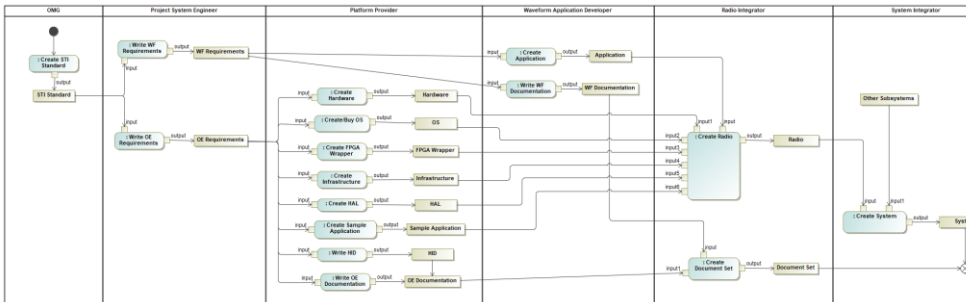
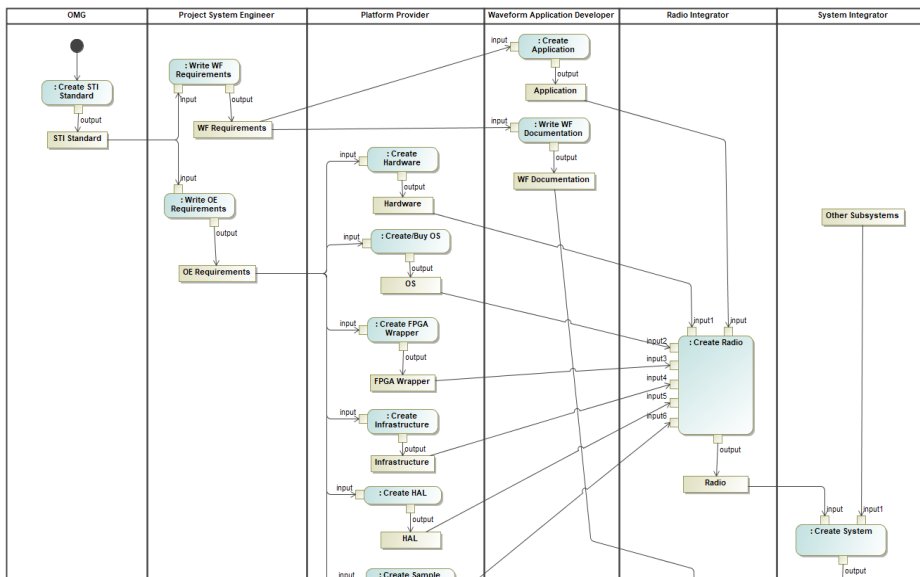

Figure 1: Roles and Responsibilities



The STI platform provider is the organization responsible for the design and development of the SDR hardware platform, including the STI OE (e.g., infrastructure, OS), and associated documentation. The OE and hardware platform are a unique set and become the SDR platform.

The STI platform provider is responsible for following:

- All documentation associated with the platform.
- Any platform-specific FPGA wrapper for adaptation of FPGA code to the platform

Formatted: Font: 10 pt, Not Italic
 Formatted: Font: 10 pt, Not Italic
 Formatted: Font: 10 pt, Not Italic
 Formatted: Centered
 Formatted: Default Paragraph Font, Font: 10.5 pt, Font color: Auto, Pattern: Clear

- Software header files specifying the required interface, including ~~constants~~ predefined values, type definitions, and structures.
- Script or software configuration file formats, any extensible markup language (XML) schema, and any transformation tool for controlling instantiation, and their associated documentation, if deemed necessary.

Commented [HLM(L2): [JIRA issue STI_31: Change "constants" to "predefined values"](#)

If the STI platform provider delegates responsibility for part of the OE to a separate infrastructure provider, the responsibility for the appropriate files and documentation may be delegated to that provider as well. If the STI platform provider delegates responsibility for part of the hardware to a separate hardware provider, the responsibility for the pertinent HID documentation may be delegated to that hardware provider as well. The STI platform provider is ultimately responsible to integrate and deliver all aspects of the platform and OE documentation.

A primary objective of STI is to facilitate the re-use of SDR components, and as such, one or more repositories containing existing, previously-developed STI components may be available for project development efforts. Any such components may be publicly available and distributed under an open-source license or a commercial/proprietary license, or may be held in a private, non-public repository that is maintained internally within the same organization.

The project design team and the STI application developer have the responsibility to evaluate the contents of any available component repositories against the SDR application requirements to determine if an existing application in a repository may be re-used by porting it to the target platform. Depending on the results of this decision, the STI application developer either creates a new application or ports an existing STI application. The STI application developer performs unit ~~tests,~~ ~~and~~ tests and documents the functionality.

The STI integrator brings the hardware platform and software application together on the SDR platform. The STI integrator could be the STI platform provider, the STI application developer(s), a mission engineer, or even a third party. The STI integrator's role is to have the application properly running on the SDR platform to meet the communication, navigation, or other functions of the mission. Once the STI radio integration is complete, it is delivered to a system integrator who incorporates it into the mission spacecraft system.

Formatted: Default Paragraph Font, Font: 10.5 pt, Font color: Auto, Pattern: Clear

8. Hardware Architecture

In addition to providing benefits by defining a standard software infrastructure for software defined radios, this specification also defines standards for the hardware portion of the radio. Hardware technologies may change more rapidly than software, and each radio implementation generally has very specific spacecraft dependencies and requirements. Therefore, the STI hardware architecture is specified as an abstract set of facilities rather than at the physical implementation level.

The architecture does not prescribe a specific hardware implementation approach. An STI hardware platform is to be delivered with a complete HID, which is described in section 8.3, [Hardware Interface Description](#). The HID specifies the electrical interfaces, logic interfaces, connector requirements, and physical requirements for the delivered radio. Each module's HID abstracts and defines the module functionality and performance.

Formatted: Font: 10 pt

8.1 Generalized Hardware Architecture

The STI radio hardware is divided logically into:

- a. a general-purpose processing module (GPM) containing the software,
- b. signal processing modules (SPM) containing programmable logic devices (PLDs), which perform any high-speed digital signal processing, and
- c. RF modules (RFM) containing the analog to digital and digital to analog converters with interfaces to the antennas.

Configurable hardware designs are realized using a hardware device such as an FPGA or other type of programmable logic device (PLD).

The hardware diagrams illustrate some likely radio functions and the interconnects for each module. The modules are a logical and functional division of common radio functions that comprise an STI platform. Modules are not intended to represent physical entities of the platform. As developers choose how to distribute and implement the radio functions among hardware elements, the specification provides the guidance on the interfaces and abstractions that are to be provided to comply with the architecture. The module and function connections provided in the diagrams are data path, control, signal clock, and external interfaces.

[Figure 2](#), Notional STI Hardware Architecture, shows the high-level STI hardware architecture. The figure illustrates the functional attributes and interfaces for each module. A module is a combination of logical and functional representations of platform and applications implemented in a radio. The modules are divided into their typical functions to provide a common description and terminology reference. Each STI platform provider has the flexibility to combine these modules and their functionality as necessary during the radio design process to meet the specific mission requirements.

Commented [HLM(L3): [JIRA issue STI_5: Correct SysML in figures](#)

Formatted: Default Paragraph Font, Font: 10.5 pt, Font color: Auto, Pattern: Clear

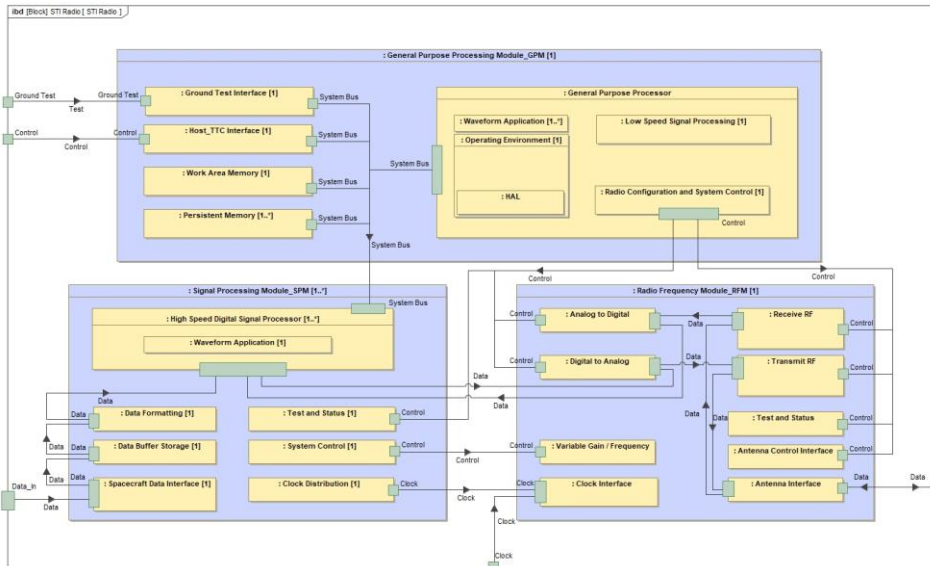

Figure 2: Notional STI Hardware Architecture

Additional modules can be added for increased capability. The hardware architecture does not specify a physical implementation internally on each module, nor does it mandate the standards or ratings of the hardware used to construct the radios. Thus, a radio supplier can encapsulate company proprietary circuit or software designs, provided the modules meet the specific architecture rules and expose the interfaces defined for each module. There is flexibility to physically combine or split these modules as necessary during the radio design process to meet the specific mission requirements or to optimize the design. For example, all RF and signal-processing components or functions may be integrated onto a single printed circuit board, easing footprint, interface, and integration issues, or an approach with multiple boards and enclosures could be used. Similarly, an FPGA could potentially contain both the Signal Processing Module (SPM) functions and the General Purpose Processor (GPP), or the Signal Processing Module (SPM) functions could be split between an FPGA and the GPM.

Each project or organization may choose to further standardize certain interfaces and physical packaging. This approach provides organizations with the flexibility to adopt different implementation standards for various project classes. Thus, if a series of radios are required with common operating requirements, physical construction details, such as bus chassis or card slice, these radios can be part of the acquisition strategy. This modularity may improve the overall cost-effectiveness of a radio system over its service lifetime.

Another example of the flexibility is where a large organization or space mission may choose to standardize the details of the RF-to-signal-processing interface. This might be done to facilitate the use of different RF modules, but the same signal processing module, for radios used for several similar missions. Figure 2 depicts radio facilities, or elements, expected for each module in a notional sense. Not all the elements shown in each module are necessarily required for implementation. This architecture specifies the functionality of each module, but it does not necessarily specify how they are implemented. Mission requirements will dictate the implementation approach to each module, and the modules required in each radio.

8.1.1 Components

The approach taken in the STI is to describe the radio hardware architecture in a modular fashion. The generic hardware architecture diagram identifies three main functional components or modules of the STI radio. Although

Formatted: Default Paragraph Font, Font: 10.5 pt, Font color: Auto, Pattern: Clear

not shown in figure 2, additional modules (e.g., optical, networking, and security) can be added for increased capability and will be included in the specification as it matures.

The hardware architecture currently consists of the following modules:

- **General-purpose Processing Module (GPM)**, which consists of:
 - A suitable general purpose processor (GPP),
 - Appropriate memory (both volatile and nonvolatile),
 - System bus,
 - The spacecraft or host telemetry, tracking, and command (TT&C) interface,
 - Ground test interface,
 - Any required components to support the radio configuration.
- **Signal-Processing Module (SPM)**, which consists of:
 - The signal processing used to handle the transformation of received digitally formatted signals into data packets, and/or
 - The conversion of data packets into digitally formatted signals to be transmitted.
 - The spacecraft data interface, which represents any required Application-Specific Integrated Circuits (ASICs), Digital Signal Processors (DSPs), FPGAs, memory, and connection fabric or bus.
- **Radio Frequency Module (RFM)**, which consists of:
 - The interfaces that control the final stage of transmission or the first stage of reception of the wireless signals, including antennas.
 - Any required RF functionality to provide the SPM with the filtered, amplified, and correctly formatted signal if acting as a receiver, and/or
 - Any required RF functionality to format, filter, and amplify the signal from the SPM if acting as a transmitter.
 - Its associated components include filters, radio frequency (RF) switches, diplexer, low noise amplifiers (LNAs), power amplifiers, analog to digital converters (ADCs), and digital to analog converters (DACs).
- **Security Module (SEC)**. Though not directly identified in the generic hardware diagram, an SEC is also being proposed to allow STI radios to support future security requirements. The details of this module will be defined in later revisions of the architecture.
- **Network Module (NM)**: The architecture supports Consultative Committee for Space Data Systems (CCSDS) and Internet Protocol (IPs) networking functions. However, the Network Module (NM) may be realized as a combination of both the GPM and SPM.
- **Optical Module (OM)**: This module supports the integration of optical equipment when used. The detail of this module will be defined in later revisions of the architecture. (It has many similarities to RFM, but for optical carriers)
- **Cognitive Module (COG)**: Though not directly identified in the generic hardware diagram, a COG is often desired to allow STI to support interference mitigation, anti-jamming, and alternate relay paths to Earth stations.

8.1.2 Functions

Test and status, fault monitoring and recovery, and radio and TT&C data-handling functions are to be implemented on all modules to some level. The details of the implementation are mission specific. The related control and interface requirements for the shared module functions are stated in the corresponding module section.

Formatted: Default Paragraph Font, Font: 10.5 pt, Font color: Auto, Pattern: Clear

Test and Status

Each module (or combination of modules) should provide a means to query the current health of the module and run diagnostics. The software methods for Query and RunTest are provided such that they may check the hardware state as well as software values.

Fault Monitoring and Recovery

Each module (or combination of modules) should incorporate detection of operational errors, upsets, and major component failures. These may be caused by the radiation environment, for example, including single-event upsets (SEUs), temperature fluctuations, or power supply anomalies. In addition to detection, mitigation and fail-safe techniques should be employed. Each module should have a default power-up mode to provide the minimal functionality required by the mission. This fail-safe mode should have minimal software and/or configurable hardware design dependency. Autonomous recovery is needed in the space environment when no operator is available.

Radio Data Path

SDRs can be implemented with or without the GPM in the data path. The STI architecture supports the separation of the RFM and SPM data paths from the GPM. Giving the GPM access to the data path as an optional capability rather than a required capability allows for a more efficient implementation for medium and small mission classes and improves the overall performance for near-term implementations. If space-qualified GPM components mature with the performance capabilities required for signal processing, the GPM can exist within the data path and take on more signal-processing functionality, increasing flexibility.

Radio Startup Process

The startup of the STI infrastructure is expected to be initiated by the STI platform boot process, so that it can receive and send external commands and instantiate applications. The startup process might include built-in tests for self-diagnostics to verify nominal system functionality. In order to control an STI platform at power-up and to recover from error conditions, an STI platform is to have a known power-up condition that sets the state of all modules. To support upgrades to the OE, an STI platform requires the ability to alter the state (boot parameters) and/or select a boot image. The exact mechanisms and procedures used will be platform and mission specific but need to be sufficient to support upgrades to OE components, such as the OS, BSP, and STI infrastructure.

8.1.3 External Interfaces

There may be several external interfaces in this architecture:

Host TT&C

The host TT&C interface represents the typically low-latency, low-rate interface for the spacecraft (or other host) to communicate with the radio. The host telemetry typically carries all information sourced within the radio. This type of information traditionally is called the telemetry data and includes health, status, and performance parameters of the radio as well as the link in use. In addition, this telemetry often includes radiometric tracking and navigation data. The command portion of this interface contains the information that has the radio itself as the destination of the information. Configuration parameters, configuration data files, new software data files, and operational commands are the typical types of information found on this interface.

Ground Test

The Ground Test Interface provides a “development-level” view of the radio and is exclusively used for ground-based integration and testing functions. It typically provides low-level access to internal parameters not typically available to the Spacecraft TT&C Interface. It can also provide access when the GPM is not functioning (i.e., during boot).

Data

The Data Interface is the primary interface for data that are sourced from the other end of the link and for data that are sunk to the other end of the link. This interface is separate from the TT&C interface because it typically has a different set of transfer parameters (protocol, speeds, volumes, etc.) than the TT&C information. A common

Formatted: Default Paragraph Font, Font: 10.5 pt, Font color: Auto, Pattern: Clear

interface point in the spacecraft for this type of interface is the spacecraft solid-state recorder rather than the spacecraft command and data-handling (C&DH) subsystem. This interface is also characterized by medium to high latency and high data rates.

Clock

The Clock Interface is used to input to the radio the frequency reference sufficient for supporting navigation and tracking. This type of input frequency reference is essential to the operation of the radio and provides references to the SPM and RFM. There does not have to be an external clock interface if the SPM or RFM contains an oscillator that performs this function

Antenna

The Antenna Interface is used to connect the electromagnetic signal (input or output) to the radiating element or elements of the spacecraft. It also includes the necessary capability for switching among the elements if required by the mission. Steering the elements, if a function of the overall telecommunications system, is possible through this interface, but it is not typically employed because of overall operational constraints.

Power

The Power Interface, which is not included on the diagram, is described as part of this specification at the highest levels. The Power Interface defines the types and conditions of the input energy to power the radio.

Mission defined

The Mission-defined Interface, which is not included in the diagram, could monitor conditions that the radio encounters such as external temperature, solar radiation, magnetic field strength, attitude, etc. The mission would assign what to do with these values. A thermal interface that monitors temperature could be used to activate a heating element or adjust dynamic factors dependent on temperature in a known way.

8.1.4 Networking Interface

A networking interface does not necessarily map directly to the SPM, GPM, or RFM. The networking interface might handle only spacecraft TT&C data or both spacecraft TT&C data and radio data. This architecture allows for those capabilities.

8.1.5 Internal Interfaces

To support the overall goals of the architecture, the internal interfaces (GPM system bus, GPM RFM control, SPM-to-GPM test, frequency reference, and data path) should be well documented and available without restriction. The GPM system bus (see figure 2) provides the primary interconnect between elements of the GPM.

The GPM system bus may provide an interface between the microprocessor, the memory elements, and the external interfaces (TT&C and Test) of the GPM. The GPM system bus is the primary interface between the GPM and the SPM, as shown in the interconnection with the major SPM processing elements. Finally, the GPM system bus provides the interface by which the re-programmable and re-configurable elements of the SDR are modified. It supports both the read and write access to the SPM elements, as well as the reloading of hardware configuration files to the FPGAs.

The interface between the GPM and the RFM is primarily a control/status interface. Various RFM elements are controlled by the set of GPM RFM control lines (see figure 2). Coming from the System Control block in the GPM, this control bus can be either fixed by the System Control function or programmed by the GPM software and validated and routed by the System Control function. It is important to have a hardware-based confirmation and limit-check on the software controlling any RFM elements. The System Control module of the GPM provides this functionality, thus keeping the GPM RFM Control bus within operational limits.

The Ground Test Interface (see figure 2) provides specific control and status signals from different modules or functions to the Ground Test Interface block. This interface is used during development and testing to validate the operation of the various radio functions. This interface is very specific to the implementation and realization of the different modules.

Formatted: Default Paragraph Font, Font: 10.5 pt, Font color: Auto, Pattern: Clear

The Frequency Reference Interface provides an important interface between the RFM and the SPM functions. It ties the two modules together in a way that allows for the SDR to implement tracking and navigation functions. The characteristics of this interface are defined by the various amounts of tracking accuracy required by the mission for the SPM to accomplish. This interface can be as simple as a single, common frequency reference that is conditioned from an outside source and distributed in the least degrading fashion possible to the SPM. Finally, the data paths are the various streams of bits, symbols, and RF waves connecting the major blocks of the primary data path. For any particular implementation, the data path or bit streams are defined by the particular application implemented in the functional blocks.

The interface between the RFM and SPM should be well-defined and have characteristics suitable for that level of conversion between the analog and digital domains. The hardware architecture can be further specified in a manner that is important for implementers to consider and follow, if the implementation dictates the necessity of particular components. Details of the GPM, SPM, and RFM are provided in subsequent sections.

8.2 Module Specification

8.2.1 General-Purpose Processing Module

Figure 3 *Figure-3*, GPM Architecture Details, provides a closeup of the GPM. The GPM consists of one or more general purpose or digital signal-processing elements and support hardware components, embedded OS, software applications and interfaces to support the configuration, control, and status of the radio. The number of processing elements and the extent of support hardware will vary depending on the mission-class processing and data-handling requirements from a single system on a chip implementation for smaller mission classes to multiple logical replaceable units (LRUs) for the largest mission classes. In addition, fault tolerance requirements can also increase the number of hardware processing elements, support hardware components, and interface points required to meet

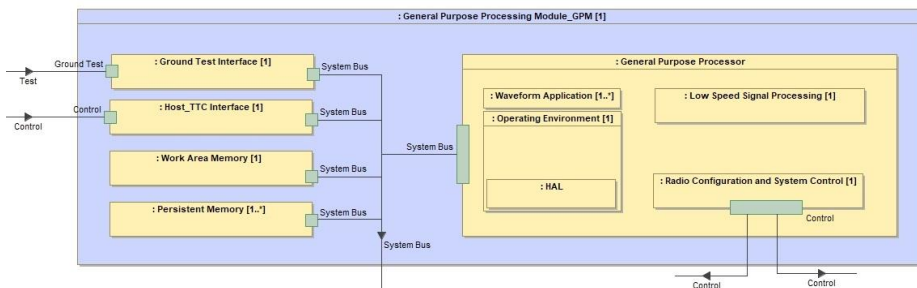

Figure 3: GPM Architecture Details (Detail of Figure 2)

the range of mission classes. The majority of processing functions of the GPM will be under software control and supported by an OS. Mission-specific data handling speeds may require the use of separate specialized support hardware (FPGA or ASIC chips) to alleviate the burden on the processing elements. Such specialized support hardware could include encryption, packet routing, and network processing functions.

GPM Components

The GPM contains, as necessary, a GPP and various memory elements as shown in **Figure 3** *Figure-3*. Depending on the particular project requirements, not all memory elements are required. The GPP will typically be implemented as a microprocessor, but it could take many forms, depending on the type of deployment. Because the GPM is the primary control component of the radio, it is a required module for an STI radio. A description of each element follows.

The GPP functions include the OE, the Hardware Abstraction Layer (HAL), and potentially application functions. The OE contains the STI infrastructure, which provides the interfaces defined by the STI APIs specification. The OE also contains the operating system and any related libraries.

Formatted: Default Paragraph Font, Font: 10.5 pt, Font color: Auto, Pattern: Clear

The *HAL* is the library of software functions in the STI OE that provides a platform-vendor-specific view of the specialized hardware by abstracting the underlying physical hardware interfaces. The HAL allows specialized hardware to be integrated with the GPM so that the STI OE can access functions implemented on the specialized hardware of the STI platform.

The *Persistent Memory Storage* element holds both the permanent (e.g. read-only memory) and reprogrammable storage for the GPP element. This is likely to be implemented using a technology such as electrically erasable, programmable read-only memory (EEPROM) or flash memory, depending on system requirements. The Persistent Memory also provides the storage for the SPM FPGA elements (i.e. configurable hardware design). The GPM may be responsible for programming and scrubbing the SPM FPGAs and, if so, would have access to the appropriate “code” for the FPGAs.

The *Work Area Memory* element is provided as operational, scratch memory for the GPP element. This memory element is implemented in concert with the GPP element and may contain both data and code, as appropriate for the execution of the radio application running in the GPM.

Finally, the GPM contains a *System Control* element to control and moderate the GPM system bus. This element provides the necessary control for the System Bus, including the various memory and SPM elements interfaced by the System Bus. In addition, the System Control element provides a validated interface to the RFM hardware via the GPM RFM Control Interface. As the software running on the GPP element commands the RFM elements into certain states, those commands are interpreted by the System Control element and validated in a manner that will prevent damaging configurations of the RFM; for example, tying the transmit amplifier directly to the receive amplifier, bypassing the diplexer element. This level of validation in the GPM-to-RFM interfaces is intended to prevent physical damage to the radio arising from a software bug. The System Control element may also be implemented by an FPGA, but if so, it should have appropriate safeguards to ensure that the FPGA cannot be modified inadvertently during flight (e.g. such as using a “permanently programmed” device or by otherwise disabling the reprogramming capabilities).

GPM Functions

The GPM will provide the overall configuration and control of the STI architecture and may include any or all of the following functions:

- Management and Control
 - Module discovery
 - Configuration control
 - Command, control, and status
 - Fault recovery
 - Encryption
- STI infrastructure, radio configuration and control.
 - Radio control
 - System management
 - Application upload management
 - Device control
 - Message center
- External network interface processing
- Internal data routing
- Waveform data link layer
 - Media Access Control (MAC) and Logical Link Control (LLC) layer
 - Physical layer processing
- Onboard data switching

Formatted: Default Paragraph Font, Font: 10.5 pt, Font color: Auto, Pattern: Clear

GPM Interfaces

- TT&C
- Ground Test
- General-purpose input output (GPIO), supporting but not limited to:
 - Interrupt source/sink
 - Application data transfer
- Control/configuration interface, supporting but not limited to:
 - RFM & SPM
 - Antenna
 - Power amplifier
- System Bus interface

For GPM Requirements

See [12.1.142-1, Provide GPM](#), and [12.1.212-2, Diagnostic Information Availability](#).

Formatted: Font: 10 pt

Formatted: Font: 10 pt

8.2.2 Signal Processing Module

[Figure 4](#), SPM Architecture Details, illustrates the SPM module. An SPM is optional for an STI platform. The SPM may implement the signal processing used to transform received digital signals into data packets and/or the conversion of data packets into digital signals to transmit. The complexity of this module is based on the applications and data rates selected for a mission. The SPM modules contain components and capabilities to manipulate and manage digital signals that need higher processing capabilities than that supplied by the GPM. The configurable hardware design architecture describes a common interface for the application on the SPM, as described in section 9.1, [Configurable Hardware Design](#).

Formatted: Font: 10 pt

Formatted: Default Paragraph Font, Font: 10.5 pt, Font color: Auto, Pattern: Clear

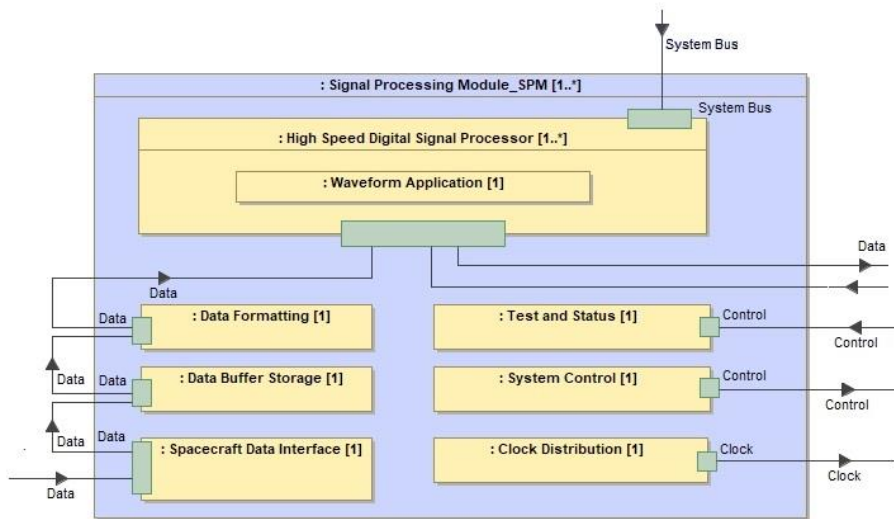

Figure 4: SPM Architecture Details (Detail of Figure 2)

SPM Components

The SPM will initially be implemented primarily with FPGAs, DSPs, reconfigurable processors, ASICs, and other integrated circuits. However, technologies will change over time, so the specific implementation is left to the STI platform provider. It is also anticipated that STI platforms may use dedicated physical hardware slices (e.g., separate circuit boards) to implement specialized applications and technologies. For example, a dedicated global positioning system (GPS) receiver slice can complement the existence of reconfigurable SPM slices in the same radio. The dedicated slice offloads demand on the less specific SPM. If an STI platform contains an SPM slice, the slice should meet the module interface specifications for control and configuration and have an interface with the GPM via the GPM system bus and the SPM-to-GPM test interface. These two interfaces work in concert to provide a control and reprogramming path to the SPM from the GPM and the application running on the GPM.

SPM Functions

The SPM implements the digital signal processing functions that convert symbols to bits and vice versa. These functions are typically implemented on FPGAs, DSPs, or ASICs. It is recommended that reconfigurable and reprogrammable devices be used because this allows for new applications to be implemented on the SDR in the future without a hardware modification. However, mission-specific requirements may dictate that the application be implemented on a non-reprogrammable hardware device.

In addition to the digital signal processing functions, a data formatting function is typically provided to convert blocks of data stored in the data storage element into bit streams appropriate for encoding into symbols and vice versa. The STI architecture does not require that these are discrete entities; in some cases, it may be possible to implement the data formatting function in the same device as the digital signal processing function.

A data storage element may be used to provide a buffer between the data interface and the bit stream coders/decoders. This data storage function can be implemented in either volatile or nonvolatile memory, depending on the operational requirements. An SPM may implement any or all of the following digital communication functions depending upon the mission waveforms:

Formatted: Default Paragraph Font, Font: 10.5 pt, Font color: Auto, Pattern: Clear

- Digital up conversion—interpolation, filtering, and “local oscillator” multiplication of baseband samples to obtain an IF or RF output sample stream appropriate for digital-to-analog conversion. This is typically the last transmit function implemented in the SPM, and the output samples are sent to the RFM.
- Digital down conversion—multiplication with “local oscillator,” downsampling, and filtering IF or RF samples to obtain a baseband output sample stream. This is typically the first receive function implemented in the SPM, with input samples coming from the analog-to-digital conversion in the RFM.
- Digital filtering—averaging, low-pass, high-pass, band-pass, polyphase, and other filters used for pulse shaping, matched filter, etc. This may overlap with some of the functionality in the up and down conversion.
- Carrier recovery and tracking—retrieval of the waveform carrier within the receive sample stream. Typical SPM functions for carrier recovery include shifting the recovered carrier frequency to compensate for local oscillator variations and Doppler shifts in the link.
- Synchronization (data, symbol, etc.)—alignment of received samples with symbol and data boundaries. There may be some integration with the digital down conversion and carrier recovery and tracking functions.
- Forward error correction coding—encoding transmit data so that receive data errors may be corrected to some level, enhancing the waveform performance.
- Digital automatic gain control (AGC)—scaling of the receive samples to optimize downstream operations.
- Symbol mapping (modulation)—translating transmit data bits to modulation symbol samples.
- Data detection (demodulation)—translating receive symbol samples to data bits.
- Spreading and despreading—a form of encoding data to obtain certain energy dispersion in the frequency domain.
- Scrambling and descrambling—a form of encoding data to ensure a certain level of randomness in the digital data stream, usually for synchronization of the receiver.
- Encryption and decryption—a form of encoding data for security purposes.
- Data Input/Output (I/O) (high-speed direct from or to source or sink)—interface for transmit and/or receive data to come in or out of the module. This may involve buffering and some protocol handling.

SPM Interfaces

The SPM’s functions and external interfaces are shown in [Figure 4](#). Interfaces shown include those common to all module types as well as those specific for the SPM. These SPM-specific interfaces may not all be required for some radios. Note that the implementation of these interfaces may combine two or more on one physical transport. For example, the Data Interface and Control and Configuration Interfaces may both use the same physical Serial Rapid I/O connection.

- Data I/O to or from RFM—This is the digital sample stream going to the RFM’s DACs for transmission, and the digital samples from the RFM’s ADCs. However, if the DACs and ADCs are preferred to be a part of the SPM, then this interface is replaced with analog baseband or IF signals.
- Waveform control and feedback to RFM—This interface will be waveform dependent. It may be used, for example, to send feedback to an AGC or control frequency hopping.
- Data interface external to the radio—High-data-rate waveforms may need a direct interface to the SPM if the GPM is not designed to handle the data.
- System bus—Data to or from GPM—This interface exchanges the packetized data for transmission and reception.
- Control and configuration from GPM—Waveform loads and reconfigurable parameters are managed through this interface.
- Test and status to GPM—Tests are initiated through this interface by the GPM, and results are returned. This is a more basic interface (electrically and protocol-wise) than the Control and Configuration interface.
- Radiometric tracking.

Formatted: Default Paragraph Font, Font: 10.5 pt, Font color: Auto, Pattern: Clear

The HID is to contain the characteristics of each reconfigurable device. Reconfigurable capacity is usually measured by the number of FPGA gates, slices, logic elements, or bytes. This information can be used by future STI application developers to determine the waveforms that can be implemented on a given platform.

8.2.3 Radio Frequency Module

The RFM handles the conversion to and from the carrier frequency, providing the SPM and/or the GPM with digital baseband or IF signals, and the transmission and reception equipment with RF to support the SPM and GPM functions. Its components typically include DACs, ADCs, RF switches, up converters, down converters, diplexers, filters, LNAs, power amplifiers, etc. Current and near-term RF technologies cannot be expected to allow multiband operation using a single channel RFM, and thus multiband radios will need to use multiple RFM slices. The RFM provides a band of frequency tunability on each slice. This tunability can be software controlled through the provided interfaces.

The RF module handles the interfaces that control the final stage of transmission or first stage of reception of the wireless signals, including antennas, optical telescopes, steerable antennas, external power amplifiers, diplexers, triplexers, RF switches, etc. These external radio equipment components would otherwise be integrated with the RFM except for the physical size and location constraints for transmission and reception. The interfaces are primarily the associated control interfaces for these components. The RFM HID encompasses the control and interface mechanism to the external components. The focus of the RF HID is to provide a standardized interface to the control of each of these devices, to synchronize the operation of the radio with any of these devices.

The other primary capability of the RFM is the conditioning and distribution of the frequency reference, as defined by the Frequency Reference Interface. This provides a common reference for the RFM and SPM modules to enable the tracking and navigation functionality typically provided by SDRs. [Figure 5](#) *Figure-5*, RFM Architecture Details, illustrates the RFM module.

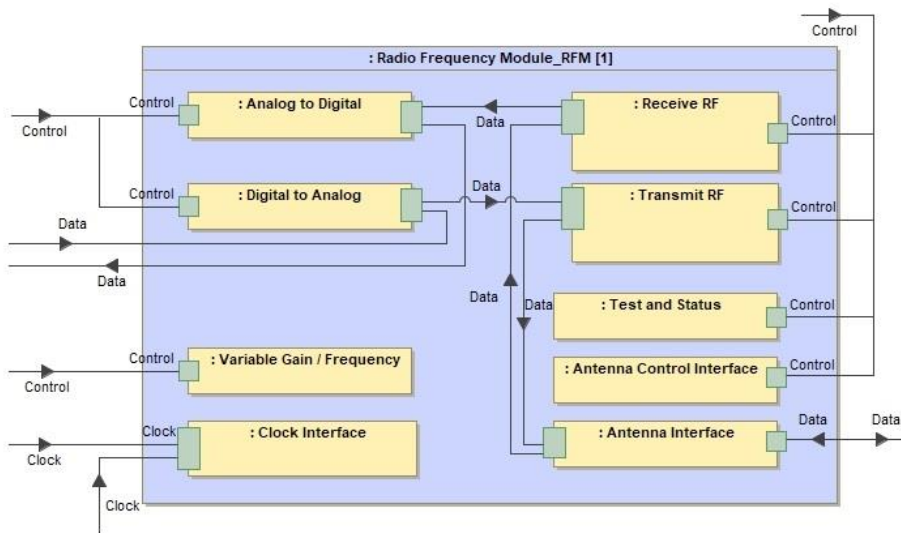

Figure 5: RFM Architecture Details (Detail of Figure 2)

RFM Components

The RFM can be implemented with a variety of integrated circuits. The control of these circuits can be implemented with a variety of different component technologies, including ASICs, discrete electronics, programmable logic

Formatted: Default Paragraph Font, Font: 10.5 pt, Font color: Auto, Pattern: Clear

devices, including FPGAs and DSPs, or even microprocessors. The choice of technologies is left up to the developer of the particular implementation.

RFM Functions

The RFM transforms the antenna signal to or from a signal usable to the radio. The RFM functions are likely to include the following:

- Frequency conversion and gain control
- Analog filtering
- Analog-to-digital and digital-to-analog conversion.
- Radiometric tracking

RFM Interface

The RFM implements the following interfaces:

- External RF interface(s) to the radio.
- Read and write access to interface registers to monitor and perform control, status, and failure and fault-recovery functions (e.g., via RS-422 or SpaceWire).
 - Control: power level tunability, frequency tunability, antenna parameter tunability, etc.
 - Status: report status of components and system operation.
 - Failure and fault-recovery functions: detect component or system failure and determine appropriate action.
 - Diagnostic test functions
- I/O for exchanging digitized waveform signal data.

For RFM Requirements

See [12.1.3+2.3, Document RF](#)~~Document RF~~

The behavior and performance of the RF modular components should be sufficiently described such that future waveform developments may take advantage of the RF capability and/or account for its performance. Information in the HID may include such items as center frequency, IF and RF frequency(s), bandwidth(s), IF and RF input/output level(s), dynamic range, sensitivity, overall noise figure, AGC, frequency accuracy and stability, and frequency-tuning resolution.

8.2.4 Security Module

The goal of the security module is to address the security services required from an SDR. There are no specific requirements for this module, but a future revision of the STI standard may add requirements or specific details. This approach supports the evolutionary nature of the STI architecture; it is expected that this module will become more well-defined as feedback is received and common interfaces are identified.

If implemented, the architecture should support selectable data-protection services for entities requiring them, providing for both confidentiality and authentication. Missions may select security options provided by the infrastructure or may develop their own.

The authentication of commands sent to SDRs is supported, including changing the configuration or uploading new programs for either the infrastructure or new applications. The security section of the architecture will include support for key management, encryption standards, and mitigating threats other than the information and communication security threats currently identified.

8.2.5 Networking Module

The STI architecture has been structured such that networks can be implemented in an SDR; that is, an SDR can be a node in a network. The SDR may be connected to another node using the appropriate logical and physical interfaces that may be wired or wireless. The STI architecture can accommodate network protocols as services that

can be made available to applications and devices. STI supports the ability to upload new software and dynamic hardware images. Advancements and replacement of existing protocols can be accomplished without affecting a spacecraft's mission resources. There are no specific requirements for this module, but a future revision of the STI standard may add requirements or specific details.

8.2.6 Optical Module

The STI architecture also supports the use of optical communications in SDRs. The optical module, if present, would logically replace the Radio Frequency Module (RFM) that is typically used for RF communication. There are no specific requirements for this module, but a future revision of the STI standard may add requirements or specific details.

STI interfacing to optical communication equipment follows the same techniques shown in integration with high-data-rate hardware. The OM would be controlled through the STI HAL interface that allows configuration and control of the digital components in the module, which abstracts the optical functionality.

8.2.7 Cognitive Module

The STI architecture supports the use of a cognitive engine used to enhance communications of SDRs. A cognitive module can be used to optimize many complex facets of the communications channel including changing the parameters of the waveform to support interference mitigation, avoid jamming, or to bypass Earth stations blocked by weather or the rotation of the Earth. A cognitive module could use sensor data about the dynamic environment to adapt to changing conditions, even learning from past experience, to respond in an optimal manner for mitigating obstacles; for example, it could use temperature data to adjust power usage or turn on climate control. By considering automation techniques including recent advances in artificial intelligence and machine learning, cognitive algorithms and related approaches enable improved resource utilization and resiliency in unpredictable or unplanned environments. There are no specific requirements for this module, but it is expected to be implemented as a service application.

8.3 Hardware Interface Description

The STI platform provider is to provide a HID document, which describes the physical interfaces, functionality, and performance of the entire platform and each platform module. The HID specifies the electrical interfaces, connector requirements, and all physical requirements for the delivered radio. The HID abstracts and describes the functionality and performance of each module. In this manner, STI application developers can know the features and limitations of the platform for their applications. The information in the HID provides the knowledge for OMG and others to integrate and test the hardware interfaces. The information in the HID may allow future module replacement or additions without the design of a completely new platform. For example, a Security Module could be added that was not originally planned, or a follow-on mission could use a different frequency band and only an RFM change would be needed. Include all waveform interfaces and any other interfaces that could be important to a waveform developer or a hardware integrator.

In addition to the GPM, SPM, and RFM HID requirements stated within each module section, the following interface descriptions and requirements are also specified for an STI platform.

For HID Requirements

See [12.1.4+2-4, Document Power-Up State](#)~~Document Power-Up State~~.

See [12.1.5+2-5, Document Hardware Capability](#)~~Document Hardware Capability~~.

See [12.1.6+2-6, Document Hardware Limitations](#)~~Document Hardware Limitations~~.

The description of the behavior and capability of modules or components available to STI application developers or reconfigurable components may include device type, processing capability, clock speeds, memory size(s), types(s), and speed(s), noting any constraints, as well as any limitation on the number of configurable hardware design reloads, as applicable, partial reload ability, built-in functionality, and any corresponding restriction on the number of gates.

See [12.1.7+2-7, Document Interfaces](#)~~Document Interfaces~~.

Formatted: Font: 10 pt

Formatted: Font: 10 pt

Formatted: Font: 10 pt

Formatted: Font: 10 pt

Formatted: Default Paragraph Font, Font: 10.5 pt, Font color: Auto, Pattern: Clear

The specific modular components or hardware slices of an STI platform will vary among different implementations. The STI platform provider or STI integrator is expected to describe each modular component and their respective physical and logical interfaces as described in this section. Table 1, Module Interface Characterization, provides typical interface characteristics to be included when identifying external interfaces or internal interfaces between modules for STI.

Table 1: Module Interface Characterization

Parameter	Description and Comments
Name	Interface name (data, control, operating power, RF, security, etc.).
Interface type	Point to point, point-multipoint, multipoint, serial, bus, other.
Implementation level	Component, module, board, chassis, remote node.
Reference documents and standards	Applicable documents for interface standards or description of custom interfaces.
Notes and constraints	Variances from standards, physical and logical functional limitations.
Transfer speed	Clock speed, throughput speed.
Signal definition	Description of functionality and intended use.
Physical Implementation	
Technology	For example, GPP, DSP, FPGA, ASIC, and description.
Connectors	Model number, pin out (including unused pins).
Data plane	Width, speed, timing, data encoding, protocols.
Control plane	Control signals, control messages or commanding, interrupts, message protocol.
Functional Implementation	
Models	Data plane model, control plane model, test bench model.
Power	Voltages, currents, noise, conducted immunity, susceptibility.
API	Custom or standard, particular to OS environment.
Software	Device drivers, development environment, and tool chain.
Logical Implementation	
Addressing	Method, schemes.
Channels	Open, close.
Connection Type	Forward, terminate, test.

8.3.1 Control and Data Interface

The control and data communications buses and links between modules within the radio are to be described by the STI platform provider to the level of detail necessary to facilitate integration of another vendor’s module. If modules communicate using the IEEE 1394, A High Performance Serial Bus, interface, for example, this will be specified in the HID with appropriate connector and pinout information. Any nonstandard protocols used should also be specified. In some cases, this may be handled by the software HAL. Module interfaces will be completely described, including any unused pins.

For Requirements for Control and Data Interface

See [12.1.8+2.8, Document the Control and Data Mechanisms](#)~~Document Control and Data Mechanisms~~.

Formatted: Font: 10 pt

Formatted: Default Paragraph Font, Font: 10.5 pt, Font color: Auto, Pattern: Clear

Besides the interface descriptions already provided for each modular component, developers should provide specific information necessary for future STI application developers to know how to interact with the command and control aspects of the platform. The description of the control, telemetry, and data mechanism of each modular component should facilitate the porting of the application software to the platform.

8.3.2 Operating Power Interface

The operating power interface description for the radio has two parts:

1. the platform as a supplier to the various modules; and
2. the power consumption of the different modules, if multiple modules are provided.

Table 2, Example Operating Power Interface, shows an example listing of a platform operating power interface. There are four distinct sets of power requirements for the platform shown. For each module delivered with the radio, as well as those built by other vendors, the HID is to specify the needed voltages, currents, and connections. Voltages are to be specified with a maximum and minimum tolerance, and associated currents are to be specified with nominal and maximum values. Connectors for operating power are to be specified, including pinouts. If power is routed through a multipurpose connector such as a backplane connector, then the pins actually used are to be documented. Power is a limited commodity for most ~~missions, and~~missions and understanding the STI platform power needs is critical.

Table 2: Example Operating Power Interface

Parameter	Values			
Voltage Rail	-15V	+2.5V	+5V	+15V
Maximum current/chassis (platform)	2A	1.7A	3A	2A
Maximum current/slot (module)	1A	1A	1A	1A
Backplane supply pins	17,19	59,61	44,46,48	21,23
Backplane return pins	18,20	60,62	43,45,47	22,24
Voltage Ripple	100 mVpp	1 mVpp	5 mVpp	100 mVpp
Notes	Slot 1 & 2 only			Slot 1 & 2 only

For Requirements for Operating Power Interface

See ~~12.1.942-9, Document Power Supply~~Document Power Supply.

Formatted: Font: 10 pt

8.3.3 Thermal Interface and Power Consumption

The power consumption and resulting heat generation of a reprogrammable FPGA will vary according to the amount of logic used, the switching rate of the waveform logic, and the clock frequency(s). The power consumption may not be constant for each possible waveform that can be loaded on the platform. The STI platform provider should document the maximum allowable power available and thermal dissipation of the FPGA(s) on the basis of the maximum allowable thermal constraints of FPGA(s) of the platform. For human spaceflight environments, touch temperature requirements may limit dissipation further; therefore, these reductions are to be factored into the given dissipation limits.

For Requirements for Thermal and Power System

See ~~12.1.1042-10, Document Thermal and Power Limits~~Document Thermal and Power Limits.

Formatted: Font: 10 pt

Formatted: Default Paragraph Font, Font: 10.5 pt, Font color: Auto, Pattern: Clear

9. Application Architecture

An example STI platform consists of one or more GPMs with GPPs, and optionally one or more SPMs containing DSPs, FPGAs, and ASICs. Application functionality may be split up according to the type of processor the function may be accomplished most efficiently on. The application component is loaded and executed on these modules to provide the signal-processing algorithms necessary to generate or receive RF signals. To aid portability and reusability, the applications use the appropriate infrastructure APIs to access platform services. Using “direct to hardware” access would increase the effort to port the application to a platform with different hardware and is discouraged. The STI infrastructure provides the APIs and services necessary to load, verify, execute, change parameters, terminate, or unload an application. The STI infrastructure implements device components that utilize the HAL or vendor-specific API to abstract communications with the specialized hardware, whereas the HID identifies the hardware interfaces and how modules are physically integrated on a platform.

The STI infrastructure utilizes separate device components to serve as a hardware abstraction layer for devices accessed by STI applications. These devices may in turn use the underlying platform HAL APIs, such as a device driver implemented to a standardized software interface. Alternatively, the device may use a custom vendor-specific API to communicate with application components on the platform specialized hardware via the physical interface defined by the STI platform provider.

9.1 Configurable Hardware Design

A configurable hardware design is one where data is used to configure a portion of the hardware without physical modification of the hardware. Configurable hardware designs are realized using a hardware device such as an FPGA or other type of programmable logic device (PLD). This section addresses the use of configurable hardware design from design and development through testing and verification and operations. It addresses aspects of model based design techniques and design for space environment applications.

Proper testing of configurable hardware design is critical to the development of reliable and reusable code. Development tools that enable early development and testing should be used so that problems can be identified and resolved early in the SDR life cycle. Many real-world signal degradations and SEUs can be simulated to identify potential issues with the waveform and waveform functions early in development, even before hardware is available. Applications implemented in configurable hardware should be modular with clear interfaces to enable individual application component simulations and incremental testing.

The configurable hardware design architecture supports the modeling of STI applications implemented in configurable hardware at the system, subsystem, and functional levels. Model-based design techniques aid in the development of modular application functions. Application development models done in a platform (or target) independent manner aid in application testing, reuse, and portability. A PIM design shall be specialized to PSMs to target different platforms. PSM design flows might include high-level models combined with manual code writing. On resource-constrained platforms, optimized code would be written. On non-resource-constrained platforms, PSMs may be used to auto generate code. These design flows can be employed to significantly reduce the porting effort.

Application portability and reusability should be considered in all facets of the design process from concept to implementation to testing. The coding technique of the application is also essential to reduce the application porting effort. Having defined syntax standards for HDLs (e.g., Verilog or VHDL) makes them appear to be easily portable across devices and software synthesizers, but this is an incorrect assumption. There are many things that can make hardware description languages hard to port. For example, the use of device-specific fixed hardware logic on the FPGA will decrease the portability. The use of specialized hardware may be necessary to meet the timing constraints of the application; however, the STI application developer should document any application function that uses the specialized hardware so that the effort to port the application function(s) can be determined. Non-boolean-type logic such as clock generation can also reduce portability. One method to decrease the porting effort would be to create a module that does the clock generation from which the rest of the application functions receive the necessary clock(s).

Development of configurable hardware design for STI radios should include provisions for mitigating space environmental effects such as SEUs. Near-term application of static random-access memory (SRAM)-based FPGAs may require triple-mode redundancy (TMR), configuration memory scrubbing, and other mitigation techniques,

Formatted: Default Paragraph Font, Font: 10.5 pt, Font color: Auto, Pattern: Clear

depending on the intended mission environment and desired reliability. Commercial design tools are becoming available to aid in this process and some newer FPGAs have versions available with embedded TMR.

A key feature of SDRs is that they can be reconfigured after deployment. The ability to load new applications and services will benefit missions in several ways, including using one SDR (instead of several separate radios) to handle different applications for various phases of a mission, some planned and some unplanned. An STI platform should receive STI application software and configurable hardware design updates after deployment.

9.2 Specialized Hardware Interfaces

Standardizing and documenting the interface from the waveform applications on the GPP to the portion of the waveform in the specialized processing hardware, such as FPGAs, is intended to provide commonality among different STI platforms and to aid portability of application functional components implemented in configurable hardware design.

The STI architecture provides a common mechanism for the software to instantiate, configure, and execute the software and configurable hardware design applications on various platforms using different hardware devices. Reconfiguration may include changing the parameters of installed applications and uploading new applications after deployment.

The application accepts configuration and control commands from the GPM and uses STI APIs that interface to the device drivers associated with the SPM and RFM modules. The device drivers communicate via the HAL on the GPM that abstracts the physical interface specification described in the HID in transferring command and data information between the modules.

For FPGAs, the interface to the application is through a platform-specific wrapper. The platform-specific wrapper accepts command and data information from the GPM and provides them to the application. The platform-specific wrapper also abstracts details of the platform from the STI application developer, such as pinout information. The platform-specific wrapper should also provide clock generation, signal registering, and synchronization functions, and any other non-waveform-specific functions that the platform requires.

Documentation of the platform-specific wrapper is necessary so that STI application developers can interface applications to the platform. This documentation should include detailed timing constraints, such as signal hold times, minimum pulse widths, and duty cycles. The signal timing constraints refer to the protocol of a particular interface describing events happening on a particular clock cycle. For clock generation, one should document what clock domains are in the design, how each clock is generated, and the resources that are involved. Signal synchronization describes any additional logic needed when clock domains are changed across the interface. The signal registering methods refer to any configurable hardware design interfaces between modules and if the input and output were registered, latched, or neither.

For Requirements for Specialized Interfaces

See [12.1.11+2.11](#), ~~Controllable From OE~~~~Controllable From OE~~;

See [12.2.1+2.12](#), ~~Platform Specific Wrapper~~~~Platform Specific Wrapper~~;

See [12.2.2+2.13](#), ~~Document FPGA Interfaces~~~~Document FPGA Interfaces~~.

Formatted: Font: 10 pt

Formatted: Font: 10 pt

Formatted: Font: 10 pt

Formatted: Default Paragraph Font, Font: 10.5 pt, Font color: Auto, Pattern: Clear

10. Software Architecture

The STI architecture is predicated on the need to provide a consistent and extensible development environment on which to construct SDR applications. The breadth of this goal implies that the specification be based on the following:

1. Core interfaces that allow flexibility in the development of application software; and
2. Hardware and software interface documentation that enable technology infusion.

10.1 Software Layer Model

The software architecture model shows the relationship between the software layers expected in an STI-compliant radio. The model illustrates the different software elements used in the software execution and defines the software interface layers between applications and the OE and the interface between the OE and the hardware platform.

[Figure 6](#) [Figure-6](#), Software Execution Model, represents the software architecture execution model. The software model achieves the following objectives:

- a) Abstracts the application from the underlying OE software to promote portability and reusability of the application.
- b) Within the abstraction layer, minimizes custom routines by using commercial software standard interfaces such as POSIX®.
- c) Depicts the STI software components as layers to specify their relationship to each other and their separation from each other which enables developers to implement the layers differently according to their needs while still complying with the architecture.
- d) Introduces a lower-level abstraction layer between the OE and the platform hardware. Note that although software abstraction for general processors is typically accomplished with board support packages and device drivers, the abstraction of hardware languages or configurable hardware design is less defined. The model represents the software and configurable hardware design abstraction in this layer.
- e) Indicates the relationship between the OE software and the different hardware processing elements (e.g., processor and specialized hardware).

The OE adheres to the interface descriptions provided in [Figure 6](#) [Figure-6](#). This specification provides two primary interface definitions, as follows: (1) The STI APIs; and (2) The STI HAL specification, each with a control and data plane specification for interchanging configuration and run-time data. The STI APIs provide the interfaces that allow applications to be instantiated and use platform services. These APIs also enable communication between application components. The HAL specification describes the physical and logical interfaces for inter-module and intra-module integration.

Formatted: Default Paragraph Font, Font: 10.5 pt, Font color: Auto, Pattern: Clear

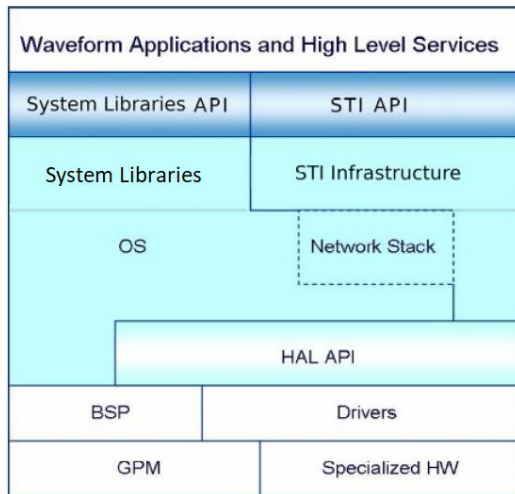

Figure 6: Software Execution Model

The STI software architecture presents a consistent set of APIs to allow waveform applications, services, and communication equipment to interoperate in meeting an application specification. [Figure 7](#), Layered Structure, represents a view of the platform OE that depicts the boundaries between the STI infrastructure provided by the STI platform provider and the components that can be developed by third-party vendors (e.g., waveform applications and services).

A key enabler of application portability and reusability is the removal of application dependencies on the infrastructure that take advantage of explicit knowledge of the infrastructure implementation. When waveforms and services conform to the API specification, they are easier to port to other STI platform implementations.

Formatted: Default Paragraph Font, Font: 10.5 pt, Font color: Auto, Pattern: Clear

Fig. 7: Layered Structure of Software Architecture from the Diagram introduced in Figure 6

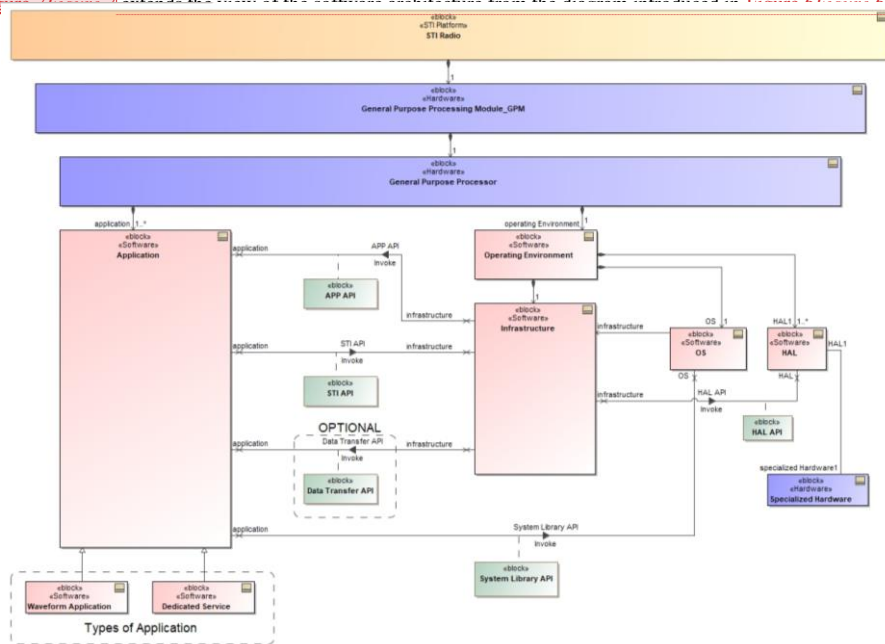

Commented [HLM(L4): JIRA issue STI_5: Correct SysML in figures
JIRA issue STI_78: Missing Clock Methods

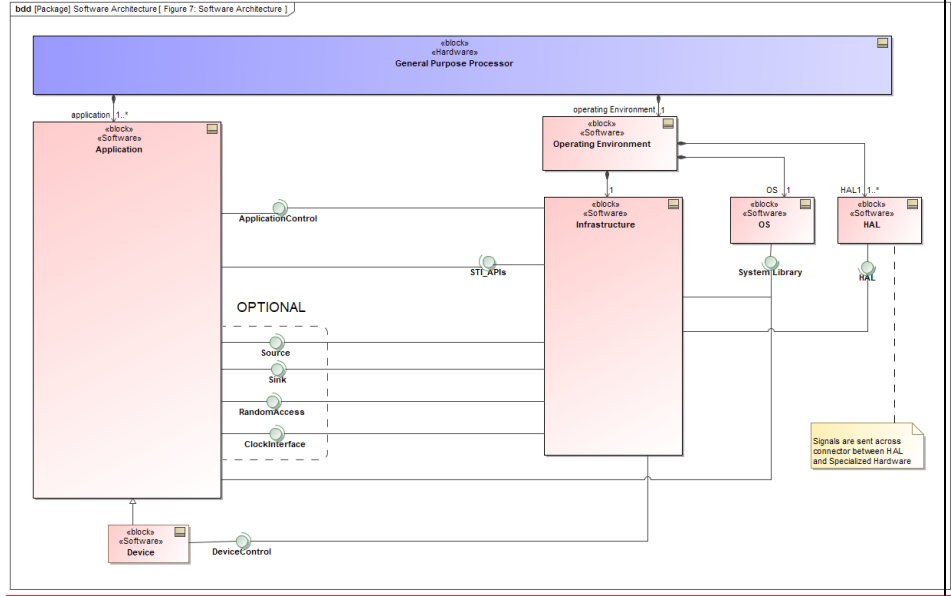

Figure 7: Layered Structure

Formatted: Default Paragraph Font, Font: 10.5 pt, Font color: Auto, Pattern: Clear

include additional detail of the infrastructure, operating system, and hardware platform using Systems Modeling Language (SysML) symbols. This approach clarifies the interfaces between components, adding additional detail.

The Operating Environment (OE) contains the OS and Infrastructure, which include System Libraries documented as allowed for that platform. In the case that the OS or platform does not support the full set of dependencies, the missing functionality is to be implemented in the STI infrastructure using a compatibility layer. For example, when using non-POSIX® OS, the compatibility layer would implement any POSIX® functions required but not implemented by the OS. The waveform applications will not directly call the driver or HAL API but use the provided STI APIs, thus providing the “abstraction layer” that helps isolate the application from the platform.

In table 3, Software Component Descriptions, the different layers of the software model shown in [Figure 7](#) are further described.

Table 3: Software Component Descriptions

Layer	Description
Waveform Application and services	Waveform application and services provide the radio GPP functionality using the STI infrastructure.
STI infrastructure	The STI infrastructure implements the behavior and functionality identified by the STI APIs as well as other required radio functionality.
STI API	The STI APIs provides consistent interfaces for the STI infrastructure to control applications and services, and for the applications and services to access STI infrastructure services.
APP API	The APP API is the interface implemented by waveforms and services whose functions are used by the STI infrastructure.
HAL	The HAL provides the device control interfaces that are responsible for all access to the hardware devices in the STI radio. The HAL API is the interface to the software drivers and BSP that communicates with the hardware.
System Library API	The specific subset of system library functions utilized by the STI waveform application. For POSIX®-based environments, this is the minimum Application Environment Profile required by the waveforms.
OS	This is the operating system that supports the POSIX® API and other OS services. The POSIX® Abstraction Layer will provide applications with a consistent AEP interface that is mapped into the chosen OS functions
System Library	This is the implementation of the system library provided by the operating system or programming language environment.
HW drivers/BSP	The hardware drivers provide the platform independence to the software and infrastructure by abstracting the physical hardware interfaces into a consistent device control API.
Driver API	OS-supplied APIs are abstracted from applications via the device control API.

Formatted: Default Paragraph Font, Font: 10.5 pt, Font color: Auto, Pattern: Clear

BSP	The BSP is the software that implements the device drivers and parts of the kernel for a specific piece of hardware. It provides the hardware abstraction of the GPM module for the POSIX®-compliant OS. A BSP contains source files, binary files, or both. A BSP contains an original equipment manufacturer (OEM) adaptation layer (OAL), which includes a boot loader for initializing the hardware and loading the OS image. Essentially, the OAL is all of the software that is hardware specific. The OAL is compiled and linked into the embedded OS.
GPM	This is the general-purpose processing module on which the STI infrastructure executes.
Specialized hardware	This is the physical layer of the hardware modules existing on the STI platform.

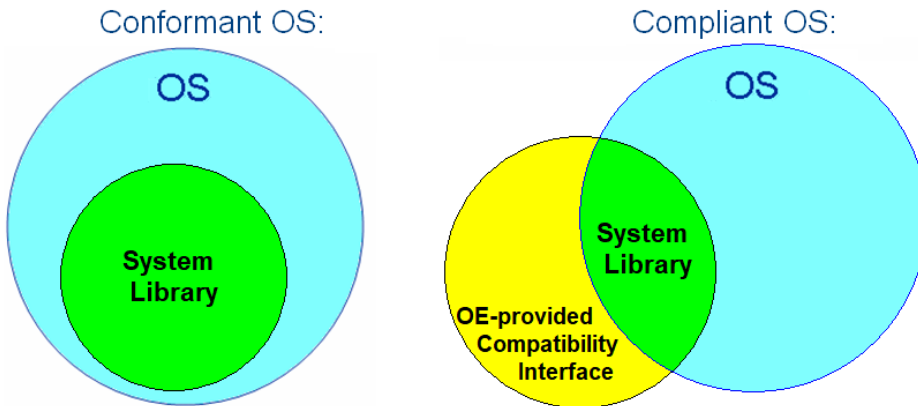

Figure 8: Standards Conformance vs. Standards Compliance

Figure 8 illustrates the difference between a standards-conformant OS and a nonconformant OS. On the left side, the prescribed set of application interfaces is provided entirely by the OS. On the right side, the OS is not directly conformant but is partially compliant. This occurs mainly when porting to a different platform with different system library support. The application profile is shown in two parts: one part shows the compliant APIs that are directly included in the OS, and the other part shows the portion of the profile that is provided through some form of abstraction or compatibility layer. For support of waveforms implemented in C/C++, the STI OE should include at least a POSIX® PSE51-conformant OS or POSIX® abstraction layer for missing APIs.

For System Library Requirements

See section 12.3.142-14, [Document System Library Interfaces Provided](#).

Formatted: Font: 10 pt

For C/C++ environments, this interface should be based on the POSIX® standard and the supported profile(s) should be indicated. For other environments, the relevant details such as the library/module name and version information should be indicated.

See section 12.3.212-15, [Document System Library Interfaces Used](#).

Formatted: Font: 10 pt

For maximum compatibility, C/C++ applications should only invoke the system library through POSIX®-compliant API calls and adhere to the smallest profile that is sufficient for application performance (e.g.

Formatted: Default Paragraph Font, Font: 10.5 pt, Font color: Auto, Pattern: Clear

PSE51). For other environments, the application should use a reasonable and customary interface for the environment.

10.2 Infrastructure

The STI infrastructure is the part of the OE that provides the functionality for the interfaces defined by the STI APIs specification. The infrastructure exposes a standard set of method names to the applications to facilitate portability. Although the STI infrastructure may use any combination of OS, BSP functions, or other infrastructure methods to implement a radio function, which may vary on different platforms, the STI APIs will be the same to allow portability. The STI APIs are the well-defined set of interfaces used by STI applications to access specific radio functions or used by the infrastructure to control the applications.

The infrastructure is composed of multiple subsystems that provide the functionality to operate the radio. The components shown in [Figure 7: Layered Structure](#)[Figure 9: Layered Structure](#), represent the high-level subsystems and services needed to control STI applications within the STI platform. These services are provided by the platform infrastructure and support applications as they execute within the STI platform. The infrastructure functions will include fault management techniques, which are necessary to increase radio robustness and support mission-dependent requirements.

10.3 API Overview

The STI APIs provide an open software specification so that the application engineers can develop STI applications. The goal is to have a standard API available to cover all application program requirements so that the application programs can be reused on other hardware systems with minimal porting effort and cost for the application implemented in software and/or configurable hardware design with increased reliability. Size, weight, and power constraints may limit the functionality of the radio by imposing a tradeoff among the following:

- The size of the API implementation,
- The size of other internal operations, and
- The size of the waveforms and services.

The size of the selected GPP should be sufficient to contain the OS, the STI infrastructure, and the appropriate portion of the waveforms and services to implement the required mission functionality, along with sufficient margin to support software upgrades. The STI APIs are defined to support internal radio commands. Any external interface commands, described in section 11, [11. External Command and Telemetry Interfaces](#)[External Command and Telemetry Interfaces](#), use the internal commands defined by the STI APIs to accomplish normal radio operations.

The API layer specification decouples the intellectual property rights of platform, application, and module developers. This allows development and interoperability of different radio aspects while protecting the investment of the developers.

The APIs in the following sections are grouped by type to simplify the description of the APIs while providing the detail for each requirement in tabular form. The table contains the name, description, parameters, return type, any additional information that is pertinent to the usage of that function. The examples shown in the table for each requirement are written from the point of view of the STI application developer.

Handle names and identifiers (i.e. `HandleID` values) have global scope within the operating environment. A handle ID is a single value that represents an STI application, device, file, or queue. A given handle identifier refers to the same application, device, file, queue, timer, or service across all applications.

A key aspect of a software architecture is the definition of the APIs that are used to facilitate software configuration and control of the target platform. The philosophy on which the STI architecture is based avoids the conflict between open architecture and proprietary implementations by specifying a minimum set of APIs that are used to execute waveform applications and to deliver data and control messages to installed hardware components. The following APIs exhibit similar functionality to a resource interface in the Object Management Group (OMG)/software radio (SWRADIO) or Software Communications Architecture (SCA 2.2.2) specifications.

Formatted: Font: 10 pt

Formatted: Default Paragraph Font, Font: 10.5 pt, Font color: Auto, Pattern: Clear

10.3.1 Interface Structure

Figure 9 Figure 9, Application and Device Structure, shows a high-level overview of the STI software interface and object definitions.

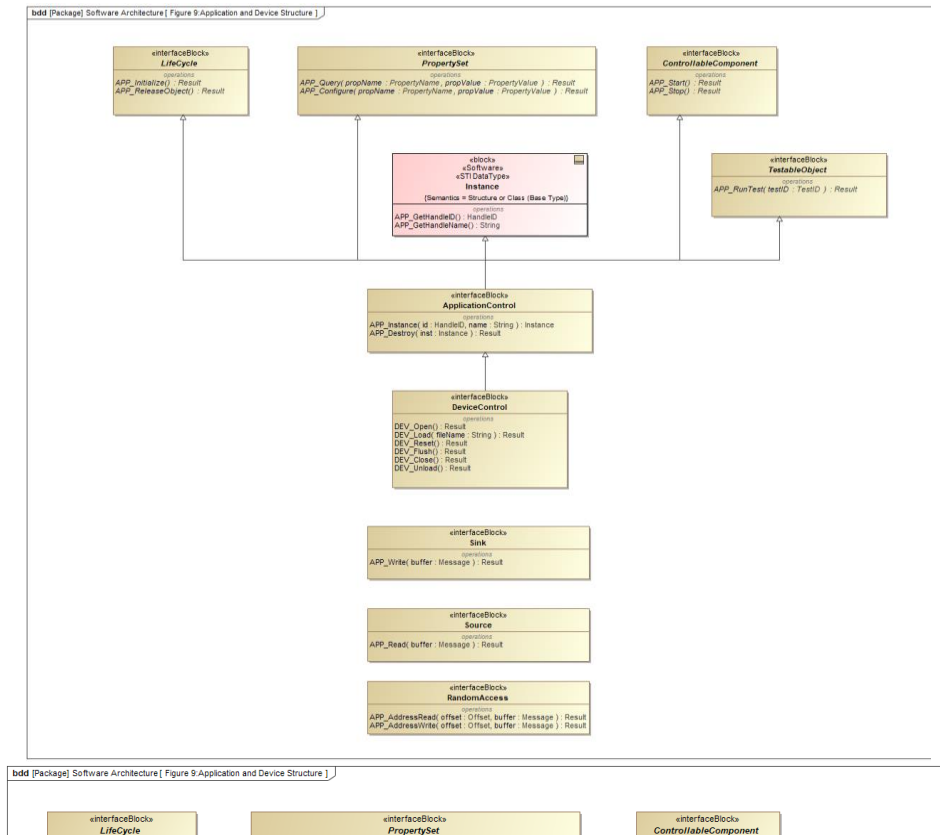

As shown in Figure 9 Figure 9, all applications and devices within the environment are derived from the Instance type, which is provided by the infrastructure and serves as a common basis point for every entity. This base type has only a minimal set of infrastructure-defined methods. All operations are defined through several control interface definitions.

The operations include:

- A means for the application or device to obtain the corresponding name and ID.
- A means to configure or query the entity state from other applications, using name/value pairs.
- A means to execute tests on the application or device
- A means to dynamically start or stop a device or service from other applications
- A means to dynamically allocate/initialize system resources when needed and release resources when no longer necessary.
- A means to “read” or pull data from this entity to other applications

Commented [HLM(L5)]: [JIRA issue STI_5: Correct SysML in figures](#)
[JIRA issue STI_78: Missing Clock Methods](#)

Formatted: Default Paragraph Font, Font: 10.5 pt, Font color: Auto, Pattern: Clear

- A means to “write” or push data to this entity from other applications

An STI application implementation (e.g., waveform) would typically implement the `ApplicationControl` interface, which includes all operations relevant for applications except those related to data transfer. An STI device would implement the `DeviceControl` interface, which provides operations specific to devices as well as all operations defined by `ApplicationControl`. Any application or device may selectively choose to implement any of the data transfer interfaces as necessary, including `Source`, `Sink`, and `RandomAccess`.

Note that from the STI perspective, “Applications” and “Devices” are very similar concepts, differing only in that a device implements the operations specified in the `DeviceControl` interface, whereas an application typically does not implement these operations. Otherwise, the two software modules are identical. Throughout the remainder of this section, the term “Application” is used, but the same features and requirements generally apply to devices as well.

For Infrastructure Software Requirements

See Section [12.3.342-16, Document Language Interfaces Provided](#) and [12.3.412-17, STI Infrastructure Uses APP API](#).

Formatted: Font: 10 pt

Formatted: Font: 10 pt

10.3.2 Implementation

An STI operating environment may support applications written in any language, so long as it provides the infrastructure API in an appropriate form for the language in use. The software interfaces in this specification utilize the OMG Interface Definition Language (IDL) syntax, and IDL language mappings provide a method to consistently translate the semantics of a given interface to many different programming languages.

For Requirements for Software Modules

See Section [12.3.512-18, Use Language Specific Facilities Specified in Annex A](#).

Formatted: Font: 10 pt

All STI applications and devices should encapsulate their state in an object or structure of some type, referred to as the “base object”. Even for “singleton” objects of which there can only be one, STI requires that there is still a base object associated with the instance, even if this object does not contain any extra information.

[Figure 9](#) also shows several different optional interfaces that an application or device may implement, depending on its specific design needs.

For Requirements instance object definition

See Section [12.3.612-19, Use Language Specific Inheritance](#).

Formatted: Font: 10 pt

See Section [12.4.212-21, Application based on Instance Object](#).

Formatted: Font: 10 pt

10.4 Data Types and **Constants**

Commented [HLM(L6): [JIRA issue STI_31: Change “constants” to “predefined values”](#)]

The following data types are defined by the infrastructure. These types serve as the basis for the STI interfaces and API calls described in the subsequent sections. The types are written in a general way that will be particularized for the implementation language and platform selected.

10.4.1 Data Types

The STI infrastructure uses the basic data types, integer, string, or enumeration. For these data types, the specification allows some flexibility in how they are implemented by the infrastructure according to the language used. Likewise, Table 5 indicates only the general behavioral semantics of the type, such as an integer, string, or enumeration. For instance, all types with integer semantics should be compatible with the standard integer assignment and relational operators per the language in use.

For enumerated types, the possible values and definitions are shown in section 10.4.2, [Predefined Values](#).

Formatted: Default Paragraph Font, Font: 10.5 pt, Font color: Auto, Pattern: Clear

For STI Infrastructure-provided Data Types

See Section [12.4.142-20](#) with Table 5: Infrastructure-provided Data Types

10.4.2 **ConstantsPredefined Values**

The STI infrastructure defines the following **constantspredefined values**. In strongly typed languages, the **constant predefined value** evaluates to a value of the specific data type as indicated.

Commented [HLM(L7)]: [JIRA issue STI_31: Change "constants" to "predefined values"](#)

For Constants Requirements see

Section [12.4.342-22](#) with Table 6: Access **ConstantsValues**

Section [12.4.442-23](#) with Table 7: CalendarKind **ConstantsValues**

Section [12.4.542-24](#) with Table 8: HandleID **ConstantsValues**

Section [12.4.642-25](#) with Table 9: Result **ConstantsValues**

Section [12.4.742-26](#) with Table 10: Handle Name **ConstantsValues**

Section [12.4.842-27](#) with Table 11: Property Name **ConstantsValues**

Section [12.4.942-28](#) with Table 12: Size Limit **ConstantsValues**

Section [12.4.1042-29](#) with Table 13: TimeWarp **ConstantsValues**

10.5 Application and Device Control Interface

The application and device interface, illustrated in [Figure 9Figure 11](#), is the mechanism through which local applications receive requests from the STI infrastructure.

All operations described in this section operate on a single context object, which is a data structure stored in local memory that contains the state of the application instance. The specific semantics of this context object depend on the language in use. In C, this context object is passed explicitly as a pointer argument to each call, which can then be cast or converted to the correct structure type. In C++ or Java, these operations are implemented as class member functions, and as such the context object is passed implicitly through the `this` reference. Other object-oriented languages have a similar paradigm to reference the context object, such as the "self" object in Python.

As a general convention, interfaces that apply to all components (applications, devices, etc.) have operations named with an APP prefix, and interfaces that apply only to devices have operations named with a DEV prefix. Further details on each of these operations are provided in the following sections.

Note that the operations listed in this section are *not* invoked directly by other applications or components in the system. The infrastructure is responsible for managing the life cycle of all context objects, and these objects are not directly exposed to other components in the system. All operation requests from other components go through the STI infrastructure, which may in turn invoke a context switch or middleware as needed, to provide the correct context for the subsequent operation. For every interface operation described in this section, there is a corresponding infrastructure-provided API call that operates on an abstract handle value rather than a context object. These handle-based API calls, as described in section 10.6, [STI APISTI API](#), are intended to be invoked from other entities.

Formatted: Font: 10 pt

10.5.1 Infrastructure-Provided **Component IdentifierInstance** Interface

The interface operations described in this section are provided by the infrastructure and may be invoked by an application or device to obtain information from the infrastructure. The interface provides a consistent means for an application or device to obtain identification information about itself.

For Infrastructure-Provided **Component IdentifierInstance** Software Requirements

See Section [12.5.142-30](#) with [Table 14Table 18](#): APP_GetHandleID() Definition.

See Section [12.5.242-31](#) with [Table 15Table 19](#): APP_GetHandleName() Definition.

Formatted: Underline

Formatted: Underline

Formatted: Default Paragraph Font, Font: 10.5 pt, Font color: Auto, Pattern: Clear

10.5.2 Application-Provided Application Control Interfaces

The operations detailed in this section are provided by the application developer.

10.5.2.1 Constructor and Destructor

For all applications, constructor and destructor functions are provided by the application developer. These functions will create and destroy an instance of the respective application's state structure, as an object of the `Instance` base type.

For applications or services that are instantiated multiple times within a single environment, the constructor will be invoked by the infrastructure for each instance. After construction, the `Instance` reference identifies the specific context object to work with for all subsequent calls interface operations. In C++ terminology, it equates to the `this` pointer.

The notion of a statically allocated "singleton" object is allowed, but the application still needs to supply a stub function for use as a constructor and destructor. In this case, the constructor may directly return the statically allocated instance, and the destructor may be empty.

Note that these methods implement the "factory" pattern in object-oriented design. As such, they are not instance methods, but rather static methods when translated to object-oriented environments.

For Application-Provided Application Control Software Requirements

See Section [12.5.3+12.32](#) with [Table 16](#) [Table 20](#): `APP_Instance()` Definition.

See Section [12.5.4+12.33](#) with [Table 17](#) [Table 21](#): `APP_Destroy()` Definition.

Formatted: Underline

Formatted: Underline

10.5.2.2 Life Cycle Interface

The Life Cycle interface is intended to provide additional control over the application start up/initialization and shutdown processes. In many cases, an application will require some allocation steps which are dependent on configuration, such as storage buffer sizes, and these configuration items may not be known at the time the constructor is invoked. This interface allows the initialization of the application to be separated from the instantiation of the application. The required application properties can then be configured after instantiation but before the initialization takes place. The shutdown process includes stopping execution of the application, releasing any resources obtained during the initialization and execution of the application, and destroying the instance created.

For Application -Provided Life Cycle Software Requirements

See Section [12.5.5+12.34](#) with [Table 18](#) [Table 22](#): `APP_Initialize()` Definition.

See Section [12.5.6+12.35](#) with [Table 19](#) [Table 23](#): `APP_ReleaseObject()` Definition.

Formatted: Underline

Formatted: Underline

10.5.2.3 Property Set Interface

The Property Set interface consists of two operations, configure and query, which operate on name/value pairs. The implementation should perform all necessary validation of the input parameters, including whether the property name specified is valid, and whether it is permissible to set or retrieve the value in the current application state. The notion of a "read-only" property is also allowed, where any attempt to configure such properties returns the `ERROR` status code.

For Application -Provided Property Set Software Requirements

See Section [12.5.7+12.36](#) with [Table 20](#) [Table 24](#): `APP_Query()` Definition.

See Section [12.5.8+12.37](#) with [Table 21](#) [Table 25](#): `APP_Configure()` Definition.

Formatted: Underline

Formatted: Underline

10.5.2.4 Test Interface

The test interface provides a means to invoke any built-in testing routines. Test routines are identified by a test ID, which is an application-defined numeric value.

Formatted: Default Paragraph Font, Font: 10.5 pt, Font color: Auto, Pattern: Clear

The application developer is responsible for documenting the test ID's which are implemented, including the purpose and any restrictions or dependencies associated with the test. For example, tests targeted toward finding manufacturing or assembly defects may only be executable as a "ground test" when the system is connected to a designated test facility. Other tests may be permissible during run-time or flight operations but may interfere with normal radio communication.

Tests may be implemented either synchronously or asynchronously (i.e. as a background operation). For synchronous tests, the status returned indicates the complete test result, with passing indicated by returning a successful status code. For asynchronous tests, the status returned indicates only if the test has been initiated. The application implementation should utilize the PropertySet interface and specify property names/values to communicate the progress and results of the test.

For Application -Provided Test Interface Software Requirements

See Section [12.5.912.38](#) with [Table 22Table 26](#): APP_RunTest() Definition.

Formatted: Underline

10.5.2.5 Controllable Component Interface

The ControllableComponent interface is intended for applications or devices to enter or exit their normal operation mode after initialization. Typically, this should not involve any additional allocation or resource acquisition, but it should only activate or deactivate the previously allocated resources.

For example, in an application designed to estimate incoming signal power, the Initialize operation (described in section 10.5.2.2, Life Cycle Interface) would allocate any buffer storage and set up the resources necessary to "tap" the incoming signal samples, but would not actually start or activate the power estimation algorithm. The Start operation described here would begin the process of taking snapshots of the incoming data and executing the power estimation algorithm. Similarly, the Stop operation would stop the active process, but it would not tear down or release any buffers or other system resources, which is the domain of the Lifecycle interface.

This interface is also applicable to devices which have the notion of a "standby" state; after initialization, the device would become ready but not active. The Start and Stop operations would put the device into its active or standby state, respectively.

For Application -Provided Controllable Component Software Requirements

See Section [12.5.1042.39](#) with [Table 23Table 27](#): APP_Start() Definition.

Formatted: Underline

See Section [12.5.1142.40](#) with [Table 24Table 28](#): APP_Stop() Definition.

Formatted: Underline

10.5.3 Device-Provided Device-Control Interface

An STI-Device is a proxy for the data and/or control path to the actual hardware. An STI-Device is a "bridge" used to decouple an abstraction from its implementation so that the two can vary independently. All operations detailed in this section are provided by the device developer or platform provider. Like the application control interface, all operations described in this section are invoked by the STI infrastructure based on requests from other entities within the environment. The operations listed below are *not* invoked directly by other applications.

The STI-Device may be implemented using any available platform-specific hardware access layer to communicate with and control the specialized hardware. While portability is not a specific goal for devices, if the hardware access layer is also standardized and/or adheres to commonly implemented patterns, then the STI device itself can also potentially be re-used in other environments with minimal modifications.

For example, many UNIX and UNIX-like RTOS operating systems implement a very similar pattern to configure and access a serial device, using a pseudo-file in the /dev filesystem combined with a defined set of ioctl() operations and "termios" C library calls. As such, an STI device abstraction for UNIX-style serial ports and other serially-connected devices could be shared among any operating environment using this style of operating system and device model. In contrast, an operating system such as Microsoft Windows® utilizes a driver architecture specific to itself, and as such any STI device abstractions written using this driver model are not likely to be portable to any other operating system. However, in either case, an STI-compliant application that accesses serial devices using the STI device abstraction would be portable to either environment.

Formatted: Default Paragraph Font, Font: 10.5 pt, Font color: Auto, Pattern: Clear

The basic operations listed in this section correspond to the DeviceControl interface as illustrated in Figure 13.

For Device-Provided Device Control Software Requirements

See Section 12.41 with Table 25: DEV_Open() Definition.

See Section 12.42 with Table 26: DEV_Load() Definition.

See Section 12.43 with Table 27: DEV_Reset() Definition.

See Section 12.44 with Table 28: DEV_Flush() Definition.

See Section 12.45 with Table 29: DEV_Unload() Definition.

See Section 12.46 with Table 30: DEV_Close() Definition.

10.5.4 10.5.3 Data Transfer Interface

The interfaces described in this section allow bulk data transfer between the component and the infrastructure. Like all other operations, this interface exists only between the infrastructure and the respective target components. The infrastructure is responsible for transporting the data between entities in the system.

The use of the interfaces described in this section are optional. Applications or devices choosing to implement this interface indicate this in the application declaration. In object-oriented languages, this is done by inheriting or implementing the Source and/or Sink interface. In non-object-oriented languages, it is indicated in an OE-specific manner.

10.5.4.1 10.5.3.1 Source Interface

The Source interface is intended for applications or devices that supply arbitrary data to other entities using a “pull” model. The specific nature of the data is not defined by this specification and should be documented by the application developer. It may represent a stream of raw data, such as ADC samples, or it may be processed data, such as a power profile or constellation of the received signal.

For Application-Provided Source Interface Software Requirements

See Section 12.5.12 12.47 with Table 31 Table 29: APP_Read() Definition.

Formatted: Underline

10.5.4.2 10.5.3.2 Sink Interface

The Sink interface is intended for applications or devices that accept arbitrary data from other entities using a “push” model. Like the Source interface, the specific nature of the data is not defined by this specification and should be documented by the application developer. It may represent a stream of raw data, such as ADC samples, or it may be higher-level data structures.

For Application-Provided Sink Interface Software Requirements

See Section 12.5.13 12.48 with Table 32 Table 30: APP_Write() Definition.

Formatted: Underline

10.5.4.3 10.5.3.3 Random Access Interface

This optional device interface provides a means to read or write data directly to a specific location within a file or device. The location specified indicates the offset from the beginning of the file, address space, or memory map of the file or device. For memory-mapped entities or devices attached to some other physical bus (e.g. I²C) this should translate to the respective bus cycles to read or write from the given location on that bus.

The register set exposed via this interface may be emulated; the implementation is free to translate or modify the request as needed by the underlying devices or hardware infrastructure. The physical bus access, if any, may go through one or more levels of indirection, and the actual physical addresses accessed may be different than the address requested.

Formatted: Default Paragraph Font, Font: 10.5 pt, Font color: Auto, Pattern: Clear

For Application-Provided Random-Access Software Requirements

See Section [12.5.1412.49](#) with [Table 33](#) [Table 31](#): APP_AddressRead() Definition.

See Section [12.5.1512.50](#) with [Table 34](#) [Table 32](#): APP_AddressWrite() Definition

Formatted: Underline

Formatted: Underline

10.5.4 Device-Provided Device Control Interface

An STI Device is a proxy for the data and/or control path to the actual hardware. An STI Device is a “bridge” used to decouple an abstraction from its implementation so that the two can vary independently. All operations detailed in this section are provided by the device developer or platform provider. Like the application control interface, all operations described in this section are invoked by the STI infrastructure based on requests from other entities within the environment. The operations listed below are *not* invoked directly by other applications.

The STI Device may be implemented using any available platform-specific hardware access layer to communicate with and control the specialized hardware. While portability is not a specific goal for devices, if the hardware access layer is also standardized and/or adheres to commonly implemented patterns, then the STI device itself can also potentially be re-used in other environments with minimal modifications.

For example, many UNIX and UNIX-like RTOS operating systems implement a very similar pattern to configure and access a serial device, using a pseudo-file in the /dev filesystem combined with a defined set of ioctl() operations and “termios” C library calls. As such, an STI device abstraction for UNIX-style serial ports and other serially connected devices could be shared among any operating environment using this style of operating system and device model. In contrast, an operating system such as Microsoft Windows® utilizes a driver architecture specific to itself, and as such any STI device abstractions written using this driver model are not likely to be portable to any other operating system. However, in either case, an STI-compliant application that accesses serial devices using the STI device abstraction would be portable to either environment.

The basic operations listed in this section correspond to the DeviceControl interface as illustrated in Figure 9.

For Device-Provided Device Control Software Requirements

See Section [12.6.1](#) with [Table 33](#): DEV_Open() Definition.

See Section [12.6.2](#) with [Table 34](#): DEV_Load() Definition.

See Section [12.6.3](#) with [Table 35](#): DEV_Reset() Definition.

See Section [12.6.4](#) with [Table 36](#): DEV_Flush() Definition.

See Section [12.6.5](#) with [Table 37](#): DEV_Unload() Definition.

See Section [12.6.6](#) with [Table 38](#): DEV_Close() Definition.:

Formatted: Underline

Formatted: Underline

Formatted: Underline

Formatted: Underline

Formatted: Underline

Formatted: Underline

10.6 STI API

The API calls in this section comprise the “public” interface into the STI infrastructure and may be used by all components in the system to initiate actions in other components. Operations primarily utilize handle ID values, which are opaque/abstract values that uniquely reference a single component within the STI infrastructure. The specific format or structure of the handle ID value is implementation-defined, but the following criteria apply:

- Handle ID values apply within a single run-time instance of an STI operating environment. They are not meaningful outside the operating environment, nor are they meaningful in a different instance of an STI operating environment. Note that a “reboot” of an environment is considered a different run-time instance; handle ID values are not required to be persistent across restarts and may be assigned differently.
- Handle ID values refer to the same component for that respective component’s lifetime; a component cannot ever change its handle ID unless that component is destroyed and re-created.
- All components within the same operating environment can refer to the same set of handle IDs, and a given handle ID referenced from one component refers to the same entity as the same handle ID referenced from a different component.

Formatted: Default Paragraph Font, Font: 10.5 pt, Font color: Auto, Pattern: Clear

- Two Handle ID values may be tested for equality using the programming language’s normal equality check operator (e.g. `if (Handle1 == Handle2)`), but all other inquiries or tests are to be performed via the infrastructure.

Portable applications and devices treat handle ID values as opaque objects, without any assumptions regarding the validity of specific values or the data type(s) capable of storing the value. Only the infrastructure-supplied `HandleID` type may be used to store a handle ID value.

It is recommended that the infrastructure implement handle IDs as an integer or a type derived from an integer, for speed and simplicity of operation, although this is not required. As such, a handle ID value should not be compared to any other integers.

10.6.1 General Utility API

The utility functions described in this section allow an application to make inquiries about the state of the infrastructure or a previous operation, and generally do not perform any operation of their own. These functions may be used at any time by any application.

10.6.1.1 Response Handling and Analysis

The function calls described in this section allow analysis of the return value of a previous call. Many STI API calls return one of four data types:

- A status code (`Result`)
- A handle ID (`HandleID`)
- A size (`FileSize`)
- A string (language-dependent)

In most circumstances, calls returning a `Result` type could test for the defined value `OK` to indicate a successful result. However, there are some API calls, mainly those that use variably-sized data buffers for reading or writing, for which partial success is permissible. In these cases, the function returns an actual size or count value rather than a fixed value upon success. For this reason, portable applications should not directly check for the specific return value `OK` to determine success of any STI call. Instead, applications should use a second operation to check if a given status code represents success or failure.

Similarly, operations that return a `HandleID` or `FileSize` type may also fail, where failure is indicated by an invalid value. A secondary check operation should be employed to determine whether the returned value is valid or not.

Finally, for functions that directly return the name of components as a string, the language in use defines the semantics of invalid responses. In C, where strings are direct pointers to memory, this is the special pointer value “NULL”. Other languages have differing representations of an “undefined value” such as `None` (Python) or `nil` (Lua), but the semantics vary from language to language. In these cases, portable applications should check the return value using the string semantics for the language in use, before passing the value to another operation.

For Infrastructure-Provided Response Handling Software Requirements

See Section [12.7.142-51](#) with [Table 35](#) [Table 39](#): `IsOK()` Definition.

See Section [12.7.242-52](#) with [Table 36](#) [Table 40](#): `ValidateHandleID()` Definition.

See Section [12.7.342-53](#) with [Table 37](#) [Table 41](#): `ValidateSize()` Definition.

- Formatted: Underline
- Formatted: Underline
- Formatted: Underline

Name to Handle ID Mappings

All components operating within an environment have an associated name and handle ID value. The name is more user-friendly, and as such is generally more useful for user interaction, whereas the numeric ID value is generally simpler and more efficient for software use. The functions described in this section provide a means to convert between these two forms of identification.

Formatted: Default Paragraph Font, Font: 10.5 pt, Font color: Auto, Pattern: Clear

For Infrastructure-Provided Handle ID Mappings Software Requirements

See Section [12.7.5+2.55](#) with [Table 39](#)[Table 43](#): GetErrorQueue() Definition.

See Section [12.7.6+2.56](#) with [Table 40](#)[Table 44](#): GetHandleName() Definition.

See Section [12.7.7+2.57](#) with [Table 41](#)[Table 45](#): HandleRequest() Definition.

Formatted: Underline

Formatted: Underline

Formatted: Underline

10.6.2 Application Control API

The operations in this section are used for controlling applications or devices from other components in the system. In [Figure 10](#), the Initialize() method call may be replaced by one of the methods in the comment titled REPLACEMENT METHOD CALLS and if so, the APP_Initialize() method is replaced by the correspondingly named method in the comment titled MATCHING METHOD CALLS. Each operation corresponds to a matching operation in the application control interface documented in section 10.4.

Formatted: Font: Not Italic

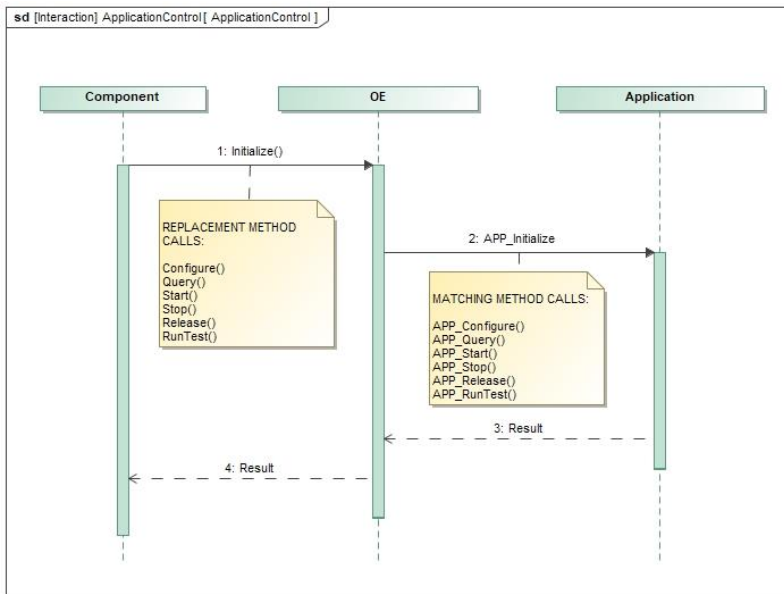

Figure 10: Sequence Diagram for Application Control Component

[Figure 10](#) illustrates the general pattern of operations between the infrastructure API calls and the corresponding interface in the target application. The left side is the request originator component, or the “from” entity in terms of the API descriptions and is identified as handle 1. The right side is the request target, or the “to” entity in terms of the API descriptions and is identified as handle 2. The originator uses the API calls described in this section, which in turn trigger the infrastructure to invoke the corresponding call on the target side. Upon completion, the return value follows the inverse path, through the infrastructure, and back to the originating component.

10.6.2.1 Setup and Teardown

The following API calls support the dynamic creation and deletion of components within the environment. See the corresponding application interface description in section 10.5.2.1 for more information.

Formatted: Default Paragraph Font, Font: 10.5 pt, Font color: Auto, Pattern: Clear

For Infrastructure-Provided Application Setup and Teardown Software Requirements

See Section [12.7.4+2.54](#) with [Table 38](#)[Table 42](#): InstantiateApp() Definition.

See Section [12.7.8+2.58](#) with [Table 42](#)[Table 46](#): AbortApp() Definition.

The interaction between the originating component, the operating environment, and the target application for an InstantiateApp call is illustrated in [Figure 11](#)[Figure 11](#).

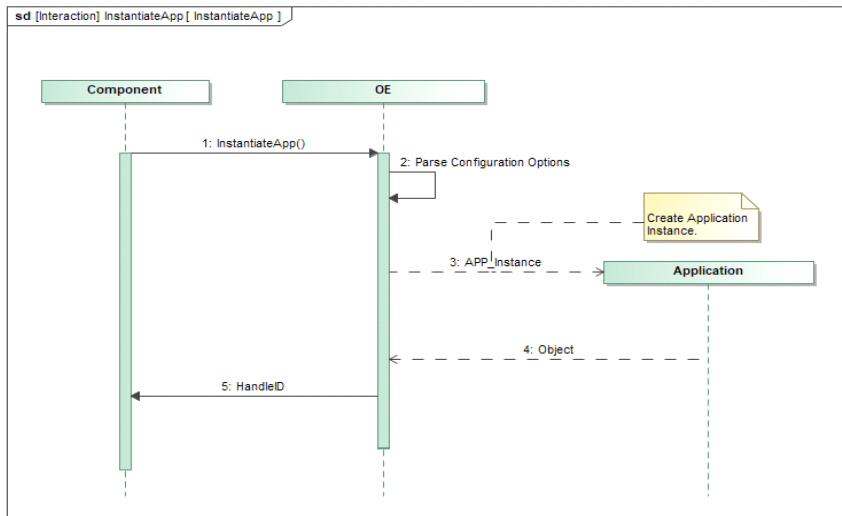

Figure 11: Sequence Diagram for InstantiateApp

The interaction between the originating component, the operating environment, and the target application for an AbortApp call is illustrated in [Figure 12](#)[Figure 12](#).

Formatted: Underline

Formatted: Underline

Formatted: Default Paragraph Font, Font: 10.5 pt, Font color: Auto, Pattern: Clear

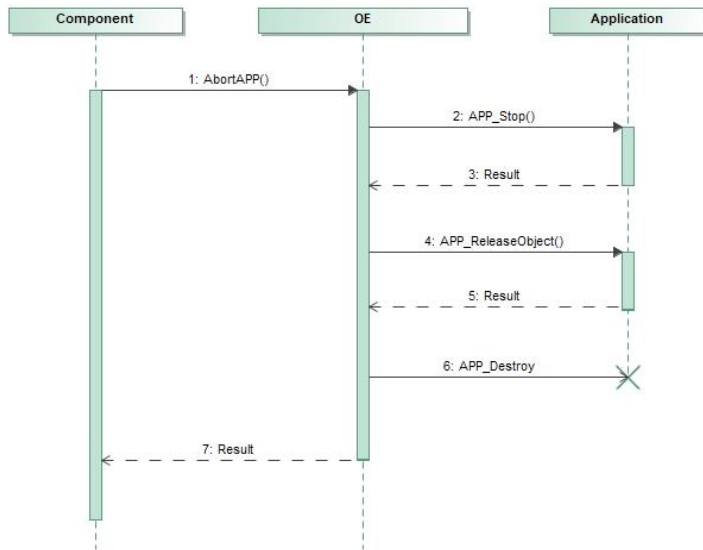

Figure 12: Sequence Diagram for AbortApp

10.6.2.2 Life Cycle Control

The following API calls correspond to the LifeCycle interface on the target component. See the corresponding application interface description in section 10.5.2.2 for more information.

For Infrastructure-Provided Life Cycle Software Requirements

See Section [12.7.912.59](#) with [Table 43](#)[Table 47](#): Initialize() Definition.

See Section [12.7.1012.60](#) with [Table 44](#)[Table 48](#): ReleaseObject() Definition.

10.6.2.3 Property Set Control

The following API calls correspond to the PropertySet interface on the target component. See the corresponding application interface description in 10.5.2.3 for more information.

For Infrastructure-Provided PropertySet Software Requirements

See Section [12.7.1112.61](#) with [Table 45](#)[Table 49](#): Configure() Definition.

See Section [12.7.1212.62](#) with [Table 46](#)[Table 50](#): Query() Definition.

10.6.2.4 Test Control

The following API calls correspond to the TestableObject interface on the target component. See the corresponding application interface description in section 10.5.2.4 for more information.

For Infrastructure-Provided Test Control Software Requirements

See Section [12.7.1312.63](#) with [Table 47](#)[Table 51](#): RunTest() Definition.

Formatted: Underline

Formatted: Underline

Formatted: Underline

Formatted: Underline

Formatted: Underline

Formatted: Default Paragraph Font, Font: 10.5 pt, Font color: Auto, Pattern: Clear

10.6.2.5 Operational Control

The following API calls correspond to the ControllableComponent interface on the target component. See the corresponding application interface description in section 10.5.2.5 for more information.

For Infrastructure-Provided Operation Control Software Requirements

See Section [12.7.1412.64](#) with [Table 48](#)[Table 52](#): Start() Definition.

See Section [12.7.1512.65](#) with [Table 49](#)[Table 53](#): Stop() Definition.

Formatted: Underline

Formatted: Underline

10.6.3 Device Control API

The following API calls allow applications to interact with STI devices. These operations provide a means to establish a path of communication to the device, and correlate to the DeviceControl interface on the target component. In [Figure 1313](#)[Figure 13](#), the DeviceOpen() method call may be replaced by one of the methods in the comment titled REPLACEMENT METHOD CALLS and if so, the Dev_open() method is replaced by the correspondingly named method in the comment titled MATCHING METHOD CALLS. Each operation corresponds to a matching operation in the device control interface documented in section [10.5.410.5.3](#).

Formatted: Font: Not Italic

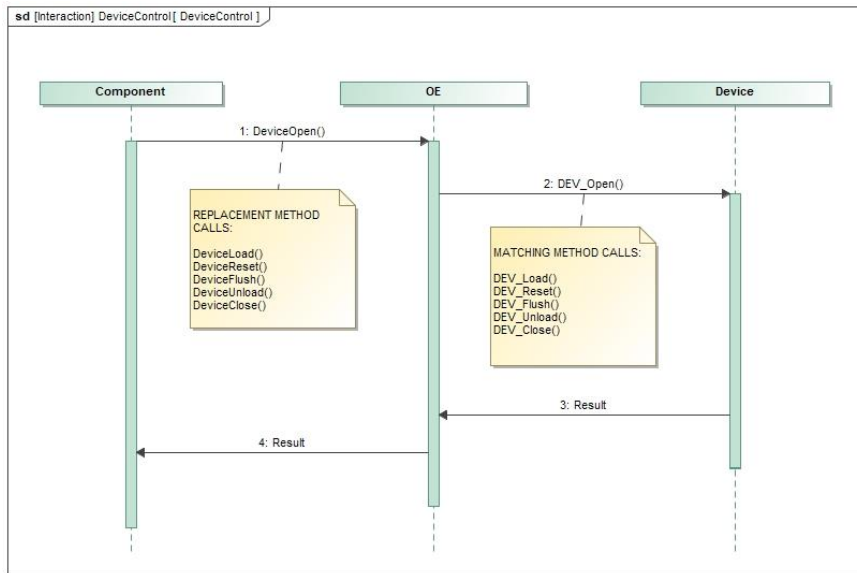

Figure 1313: Sequence Diagram for Device Control Component

For Infrastructure-Provided Device Control Software Requirements

See Section [12.7.1612.66](#) with [Table 50](#)[Table 54](#): DeviceOpen() Definition.

See Section [12.7.1712.67](#) with [Table 51](#)[Table 55](#): DeviceLoad() Definition.

See Section [12.7.1812.68](#) with [Table 52](#)[Table 56](#): DeviceReset() Definition.

See Section [12.7.1912.69](#) with [Table 53](#)[Table 57](#): DeviceFlush() Definition.

See Section [12.7.2012.70](#) with [Table 54](#)[Table 58](#): DeviceUnload() Definition.

See Section [12.7.2112.71](#) with [Table 55](#)[Table 59](#): DeviceClose() Definition.

Formatted: Underline

Formatted: Underline

Formatted: Underline

Formatted: Underline

Formatted: Underline

Formatted: Underline

Formatted: Default Paragraph Font, Font: 10.5 pt, Font color: Auto, Pattern: Clear

10.6.4 Data Transfer API

The following API calls correspond to the data transfer (Source, Sink, RandomAccess) interfaces on the target component. These functions are also used to transfer data to or from files or message queues.

10.6.4.1 Data Source

The data source operation described in this section is applicable to any application or device that implements the “Source” interface. See the corresponding application interface description in section [10.5.3.1](#) ~~10.5.4.1~~ for more information.

For Infrastructure-Provided Source Software Requirements

See Section [12.7.22](#) ~~12.72~~ with [Table 56](#) ~~Table 60~~: Read() Definition.

Formatted: Underline

10.6.4.2 Data Sink

The data sink operation described in this section is applicable to any application or device that implements the “Sink” interface. See the corresponding application interface description in section [10.5.3.2](#) ~~10.5.4.2~~ for more information.

For Infrastructure-Provided Sink Software Requirements

See Section [12.7.23](#) ~~12.73~~ with [Table 57](#) ~~Table 61~~: Write() Definition.

Formatted: Underline

10.6.4.3 Random Access

These operations provide a means to directly access specific locations within a device or file, and correlate to the RandomAccess interface on the target component. See the corresponding application interface description in section [10.5.3.3](#) ~~10.5.4.3~~ for more information.

For Infrastructure-Provided Random Access Software Requirements

See Section [12.7.24](#) ~~12.74~~ with [Table 58](#) ~~Table 62~~: AddressRead() Definition.

Formatted: Underline

See Section [12.7.25](#) ~~12.75~~ with [Table 59](#) ~~Table 63~~: AddressWrite() Definition.

Formatted: Underline

10.6.5 Log API

The Log API provides a means to record contextual information regarding errors or other conditions present in applications. The log data is maintained by the infrastructure and may be sent to the operating system log facility if one exists. The platform provider indicates the specific manner with which log data may be retrieved and examined by the operator, such as a file location or system log viewer.

See Section [12.7.26](#) ~~12.76~~ with [Table 60](#) ~~Table 64~~: Log() Definition.

Formatted: Underline

10.6.6 File API

The API calls described in this section allow an STI application or device to open, close, and manipulate files, in an abstract sense, within the operating environment. Note that the file system implemented by the STI infrastructure may or may not correspond to an actual file system in the underlying operating system. The file system may be virtualized, and the presence of these API functions does not imply a requirement that the operating system actually implements a conventional file system.

The basic requirements of the file system abstraction are:

- All applications and devices access the same file system (real or virtual). A file created by one application or device, may be subsequently opened by a different application or device, using the same file name.

Formatted: Default Paragraph Font, Font: 10.5 pt, Font color: Auto, Pattern: Clear

- The files are persistent for at least the lifetime of the current infrastructure. A virtual file system backed in RAM or other volatile storage may be cleared when the infrastructure is restarted, or the host system is rebooted. File systems should have longer persistence (i.e. across reboots) when backed by a non-volatile storage device.

The platform developer must indicate the level of persistence offered by the file system abstraction.

The methods defined in this section pertain to file system manipulation and provide a means to open or close file handles. For actual data transfer operations, file handles will respond to the data transfer methods as defined in section 10.6.4, [Data Transfer API](#)~~Data Transfer API~~.

Formatted: Font: 10 pt

10.6.6.1 File Handle Operations

Like other components, files in STI operating environment are identified using a handle ID, and as such file handles share many of the same semantics with other applications and devices. The difference lies in that file handles are obtained using the specific API methods described here, rather than the previously described methods used for applications or devices. The operations in this section manipulate file handles within the environment.

See Section [12.7.27](#)~~12.77~~ with [Table 64](#)~~Table 65~~: FileOpen() Definition.

Formatted: Underline

See Section [12.7.28](#)~~12.78~~ with [Table 62](#)~~Table 66~~: FileClose() Definition.

Formatted: Underline

Formatted: Underline

10.6.6.2 File System Operations

The operations in this section manipulate or query the file system itself, rather than on file handles within the file system.

See Section [12.7.29](#)~~12.79~~ with [Table 63](#)~~Table 67~~: FileGetSize() Definition.

Formatted: Underline

See Section [12.7.30](#)~~12.80~~ with [Table 64](#)~~Table 68~~: FileRemove() Definition.

Formatted: Underline

See Section [12.7.31](#)~~12.81~~ with [Table 65](#)~~Table 69~~: FileRename() Definition.

Formatted: Underline

See Section [12.7.32](#)~~12.82~~ with [Table 66](#)~~Table 70~~: FileGetFreeSpace() Definition.

Formatted: Underline

Formatted: Underline

10.6.7 Messaging API

The STI applications use the Messaging API to establish facilities to send messages between components using a common handle ID. The ability for applications, services, devices, or files to communicate with other STI applications, services, devices, or files is crucial for the separation of radio functionality among independent components. When using the message passing API, the final destination of a message is not necessarily known to the producer of the message.

For example, the receive and transmit telecommunication functionalities can be separated between two applications. Another example is when commands or log messages come from several independent sources and are merged appropriately. Some examples of independent components that may need to interact with others could be for navigation, GPS, file upload, file download, and computations.

There are two models for passing messages: queues (first in, first out, or FIFO) and publish/subscribe (PubSub). In a queue, messages are written to a queue by one entity and read from the queue by another entity. In a PubSub model, messages written to the message passing facility by one application are delivered to all subscribers of that publisher.

To write to or read from a FIFO queue, the Read() and Write() operations are used, respectively, as described in section 10.6.4, [Data Transfer API](#)~~Data Transfer API~~. In this model, the originating entity pushes data to the queue, where it is temporarily stored. The receiving entity pulls data from the queue later, at which time it is removed from the queue. By definition, FIFO queues only provide sequential data, they do not support random access.

Formatted: Font: 10 pt

In the publish/subscribe (PubSub) messaging model, the data is pushed to all subscribers using a one-to-many distribution. All applications subscribing to receive data using this model are required to implement the "Sink" interface as described in section 10.5.4.2. Note that any handle ID capable of acting as a data sink may be subscribed to a PubSub message distribution, including files and FIFO queues. By registering an open file handle ID, one can effectively create a "tap" to log all published data. Likewise, by registering a FIFO queue, the two

Formatted: Default Paragraph Font, Font: 10.5 pt, Font color: Auto, Pattern: Clear

messaging models may be combined, allowing broadcast data to be buffered and then “pulled” by the receiver as time permits.

10.6.7.1 *FIFO Queue Model*

The API calls described in this section implement the “first-in, first-out” (FIFO) queue model.

See Section [12.7.3312.83](#) with [Table 67](#)[Table 71](#): `MessageQueueCreate()` Definition.

See Section [12.7.3412.84](#) with [Table 68](#)[Table 72](#): `MessageQueueDelete()` Definition.

Formatted: Underline

Formatted: Underline

10.6.7.2 *Publish/Subscribe Model*

The API calls described in this section implement the publish/subscribe messaging model.

See Section [12.7.3512.85](#) with [Table 69](#)[Table 73](#): `PubSubCreate()` Definition.

See Section [12.7.3612.86](#) with [Table 70](#)[Table 74](#): `PubSubDelete()` Definition.

See Section [12.7.3712.87](#) with [Table 71](#)[Table 75](#): `Register()` Definition.

See Section [12.7.3812.88](#) with [Table 72](#)[Table 76](#): `Unregister()` Definition.

Formatted: Underline

Formatted: Underline

Formatted: Underline

Formatted: Underline

10.6.8 Time API

The STI Infrastructure Time methods are used to access the hardware and software timers. Methods are also defined to support synchronization of oscillators or other timing sources to a reference signal.

Many time operations utilize an object type called `TimeWarp`, which represents an abstract time interval.

Nominally, the `TimeWarp` object is expected to be some form of timer tick counter, with the specific resolution/units and epoch being implementation-defined. A `TimeWarp` object may represent time in standardized units, such as milliseconds or microseconds, or it may be based on the CPU clock or timer interrupt frequency. Although some API methods are defined to a nanosecond time resolution, that does not imply that the actual timer resolution is nanoseconds or that the underlying `TimeWarp` object contains its data in nanoseconds.

The following is true of `TimeWarp` objects:

- The resolution or units of `TimeWarp` objects is a fixed constant defined by the infrastructure and does not change for the lifetime of the infrastructure. For instance, if a clock is sampled at times A, B, and C, and the time interval between B-A and C-B is equal, then the corresponding difference between the successive `TimeWarp` values will also be equal.
- All [clock device/clock components](#) within an infrastructure will share the same definition of `TimeWarp`, with respect to range and resolution, even if the [clock device/clock components](#) do not share the same epoch.
- `TimeWarp` objects will be capable of differentiating between positive intervals (time in the future) and negative intervals (time in the past).

Depending on the application, time intervals may be of a long duration (years or decades) and/or high resolution (microseconds or nanoseconds). To support a wide range of time while also maintaining a high resolution, it may not be possible to represent a `TimeWarp` value as a single value on a particular CPU. For instance, if a timer has a resolution of 1 microsecond and is represented using a 32-bit signed integer, which is the largest native integer type on some microcontrollers, then the measurable time intervals would be limited to only $(2^{31}-1)$ microseconds, or approximately 35.7 minutes. Therefore, `TimeWarp` may be implemented as a structure or other extended-range numeric type in order to achieve the necessary range and resolution requirements.

10.6.8.1 *Time Conversion and Arithmetic*

The `TimeWarp` object is defined by the infrastructure as a value that represents a specific interval in time. The specific structure of this object is implementation-defined. For example, the underlying `TimeWarp` object could count ticks from some epoch, such as the infrastructure boot time, and then `GetSeconds` and `GetNanoseconds` compute the seconds and nanoseconds, respectively, based on the tick rate.

Formatted: Default Paragraph Font, Font: 10.5 pt, Font color: Auto, Pattern: Clear

The following methods provide a means to work with `TimeWarp` objects, and to convert or translate these objects into other representations. As the specific implementation of the `TimeWarp` object may vary, applications cannot assume that normal arithmetic or logical operations are possible (i.e. addition or subtraction, equality testing, etc.). Therefore, the infrastructure needs to explicitly provide these operations in the API.

In order to make these operations as efficient as possible, all operations defined in this section may be implemented as macros or inline functions on platforms that offer this feature. There is also no need for error checking and no possibility of failure on these operations, as any input value is valid.

See Section [12.7.39](#) with [Table 73](#): `GetNanoseconds()` Definition.

See Section [12.7.40](#) with [Table 74](#): `GetSeconds()` Definition.

See Section [12.7.41](#) with [Table 75](#): `GetTimeWarp()` Definition.

See Section [12.7.42](#) with [Table 76](#): `TimeAdd()` Definition.

See Section [12.7.43](#) with [Table 77](#): `TimeSubtract()` Definition.

See Section [12.7.52](#) with [Table 90](#): `ConvertToTimeWarp()` Definition

Formatted: Underline

Formatted: Underline

Formatted: Underline

Formatted: Underline

Formatted: Underline

10.6.8.2 Basic Clock Get/Set Operations

The API calls described in this section implement the basic clock operations such as getting the time, setting the time, or suspending/delaying operation until the clock reaches a specific value.

See Section [12.7.44](#) with [Table 78](#): `GetTime`,

See Section [12.7.45](#) with [Table 79](#): `SetTime`,

See Section [12.7.46](#) with [Table 80](#): `GetCalendarTime`,

Formatted: Underline

Formatted: Underline

Formatted: Underline

Several predefined `constants` for the `CalendarKind` type are specified in section 10.4.2. A compliant platform does not necessarily need to implement all the calendar types listed and may implement additional types not listed as application-specific extensions. To support the various time representations, several structures are provided by the infrastructure. The time representations are illustrated in Figure 14, Calendar Time Value Representations.

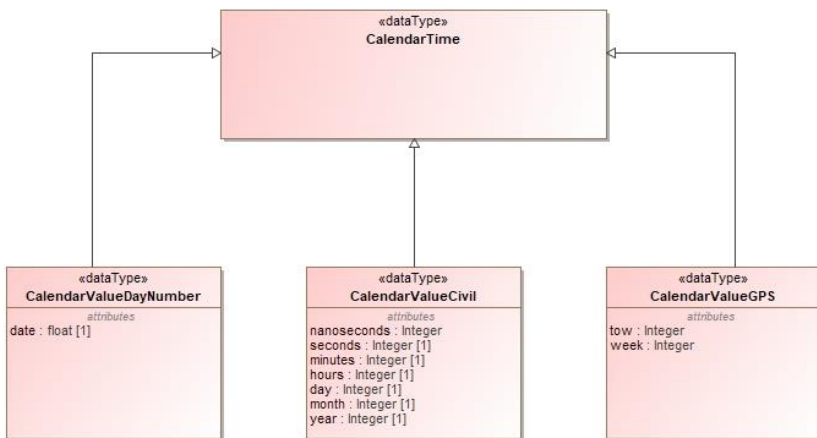

Figure 14: Calendar Time Value Representations

Formatted: Default Paragraph Font, Font: 10.5 pt, Font color: Auto, Pattern: Clear

The `CalendarTime` type may be expressed as an IDL union of all possible time representations, as indicated below.

See Section [12.4.11](#) [12.97](#) with [Table 81](#) [Table 14](#): `CalendarValueCivil` Structure Definition.

See Section [12.4.12](#) [12.98](#) with [Table 82](#) [Table 15](#): `CalendarValueGPS` Structure Definition.

See Section [12.99](#) [12.4.13](#) with [Table 83](#) [Table 16](#): `CalendarValueDayNumber` Structure Definition.

See Section [12.100](#) [12.4.14](#) with [Table 84](#) [Table 17](#): `CalendarTime` Union Definition.

Formatted: Underline

Formatted: Underline

Formatted: Underline

Formatted: Underline

10.6.8.3 Clock Rate Adjustment and Drift Compensation

If `clock-device-clock-component`s require synchronization with external signals, a dedicated service should continuously monitor for drift and handle the adjustment as needed. Common synchronization sources include a “time at tone” signal from a ground station, a 1 pulse per second (PPS) input from a GPS receiver, or via the network time protocol (NTP). Differences between the synchronization source and the `clock-device-clock-component` can be compensated by either directly stepping the `clock-device-clock-component` using `SetTime()`, or, if the underlying device supports it, by low-level adjustment of the clock source tick rate such that the drift is gradually absorbed and corrected over time.

The `SetTime()` API sets the clock directly and will step the timer forward or backward as indicated. However, a timer step may have undesirable consequences for some software, particularly control loops that rely on relative time differences between successive samples. This can sometimes be mitigated by making many small steps rather than one large step. However, even the smallest step still might cause unacceptable effects on a control loop that relies on precise relative timing measurements.

The adjustment functions are intended to address this by providing an alternative method to adjust for clock drift. In many `clock-device-clock-component` implementations, the underlying “tick” or reference signal is supplied using a hardware PLL/oscillator or clock divider of some type, driving a periodic timer tick interrupt to the CPU. Furthermore, if the source allows some level of control during operation, such as increasing or decreasing the oscillator rate by a certain ratio (e.g. parts per million) or by modifying the clock divider ratio by a small amount, then this can be used to provide for a more stable drift compensation method. By increasing or decreasing the underlying timekeeping tick rate, small differences between the `clock-device-clock-component` and the reference source can be compensated over time without ever “stepping” the clock.

Support for these adjustment routines is platform dependent. If a platform does not support clock drift adjustment, an appropriate error code will be returned.

See Section [12.7.47](#) [12.101](#) with [Table 85](#): `SetTimeAdjust()` Definition.

See Section [12.7.48](#) [12.102](#) with [Table 86](#): `GetTimeAdjust()` Definition.

See Section [12.7.49](#) [12.103](#) with [Table 87](#): `TimeSynch()` Definition

Formatted: Underline

Formatted: Underline

Formatted: Underline

10.6.8.4 Delay Operations

The `Sleep` and `DelayUntil` functions provide a means for an algorithm to delay its own execution or wait for a clock to reach a certain deadline.

See Section [12.7.50](#) [12.104](#) with [Table 88](#): `Sleep()` Definition

See Section [12.7.51](#) [12.105](#) with [table 89](#): `DelayUntil()` Definition.

Formatted: Underline

Formatted: Underline

10.6.9 Clock Control API

The following API calls allow applications or devices to act as STI clock components. The operations below provide a means to establish a path of communication to the STI clock components, and correlate to the `ClockControl` interface on the target component. There are corresponding OE methods without the “CLK_” prefix in Section [12.7.44](#) to Section [12.7.51](#) as described above.

Commented [HLM(L8)]: [JIRA issue STI_78: Missing Clock Methods](#)

For Infrastructure-Provided Clock Control Software Requirements

See Section [12.9.1](#) with [Table 91](#): `CLK_GetTime()` Definition

Formatted: Default Paragraph Font, Font: 10.5 pt, Font color: Auto, Pattern: Clear

[See Section 12.9.2 with Table 92: CLK_SetTime\(\) Definition](#)
[See Section 12.9.3 with Table 93: CLK_SetTimeAdjust\(\) Definition](#)
[See Section 12.9.4 with Table 94: CLK_GetTimeAdjust\(\) Definition](#)
[See Section 12.9.5 with Table 95: CLK_Sleep\(\) Definition](#)
[See Section 12.9.6 with Table 96: CLK_DelayUntil\(\) Definition](#)

10.7 Non-STI Software Interfaces

STI applications and services may need to utilize libraries or services outside the scope of STI, such as the services provided by the operating system or additional software libraries. As such, an STI module can only be ported to an environment that also provides a compatible set of services or libraries, so it is critical to identify these dependencies.

Examples of software libraries include, but are not limited to:

- Operating system operations such as task/thread creation or synchronization
- Floating-Point mathematical operations
- Complex algorithms, such as machine learning

Most programming languages, including C/C++, also define a “standard library” in addition to the language syntax and semantics. This library is defined by the respective standards body, such as ISO/IEC for C and C++, as a set of interfaces that all compliant implementations must meet. For instance, in ISO/IEC 9899 (C), this standard library includes a minimum set of header files specifying a core set of function calls, including basic memory access, mathematical operations, and string manipulation (e.g. `memset()`, `strcmp()`, `sqrt()`, etc.).

An STI application may use any operations defined in the standard library of the respective programming language. However, the application developer should avoid the use of any library functions which are marked as deprecated, non-cross-platform, or non-thread-safe, where applicable. If no replacement or alternative exists, this dependency should be expressly noted in the application documentation.

Beyond the standard library, additional software libraries may be used for specific functions. These include, but are not limited to:

- Accessing operating system or task scheduling resources (e.g. POSIX® or other operating system abstraction library)
- Additional mathematical computations beyond those provided by the standard library (e.g. BLAS, LAPACK, NumPy, etc.)
- Scientific or Machine Learning packages (e.g. SciPy, TensorFlow™, etc.)

10.7.1 Operating System Interface

STI applications implemented in C or C++ which do not leverage a specific 3rd party operating system abstraction library may use a subset of the POSIX® API as shown in [Figure 6/figure-8](#), Software Execution Model. POSIX® refers to a family of IEEE standards 1003.n that describe the fundamental services and functions necessary to provide a UNIX®-like kernel interface to applications. POSIX® itself is not an OS but is instead specifies the programming interfaces available to the application programmer.

POSIX® specifies a set of OS interfaces and services. The specification is not bound to a single operating system and has in fact been implemented on top of operating systems such as Digital Equipment Corporation’s (DEC’s) OpenVMS™ (Virtual Memory System) and Microsoft Windows®. However, the creation of POSIX® is closely coupled to the UNIX® OS and its evolution. The goal was to create a standard set of interfaces that all the UNIX® flavors would support in order to facilitate software portability. Even though POSIX® technically refers to the family of specifications, it is more commonly used to refer specifically to IEEE 1003.1, Information Technology - Portable Operating System Interface (POSIX®), which is the core POSIX® specification.

Formatted: Default Paragraph Font, Font: 10.5 pt, Font color: Auto, Pattern: Clear

Characteristics of POSIX® include the following:

- Application-oriented.
- Interface, not implementation.
- Source, not object, portability.
- The C-language/system interfaces written in terms of the ISO C standard.
- No superuser, no system administration.
- Minimal interface, minimally defined—core facilities of this specification have been kept as minimal as possible.
- Broadly implementable.
- Minimal changes to historical implementations.
- Minimal changes to existing application code.

The original POSIX® specification was based on a general-purpose computing platform, but a series of amendments addressed the unique requirements of real-time computing. These amendments follow:

- IEEE 1003.1B-Realtime Extension.
- IEEE 1003.1C-Threads Extension.
- IEEE 1003.1D-Additional Realtime Extensions.
- IEEE 1003.1J-Advanced Realtime Extensions.
- IEEE 1003.1Q-Tracing.

These amendments were rolled into the base specification in version IEEE 1003.1-1996. IEEE 1003.13 provides a standards-based option for an STI AEP.

10.7.1.1 STI Application Environment Profile

The subset of the POSIX® API described below is used by STI applications to access platform services when no STI Infrastructure-provided API is available. The IEEE 1003.1 standard provides a means to implement a subset of the interfaces by using “Subprofiling Option Groups.” These option groups specify “Units of Functionality” that can be removed from the base POSIX® specification.

IEEE 1003.13 created four AEPs that specified subsets of 1003.1 more suitable to embedded applications. These profiles follow:

- PSE51—Minimal Realtime Systems Profile.
- PSE52—Realtime Controller System Profile.
- PSE53—Dedicated Realtime System Profile.
- PSE54—Multi-Purpose Realtime System Profile.

Formatted: Default Paragraph Font, Font: 10.5 pt, Font color: Auto, Pattern: Clear

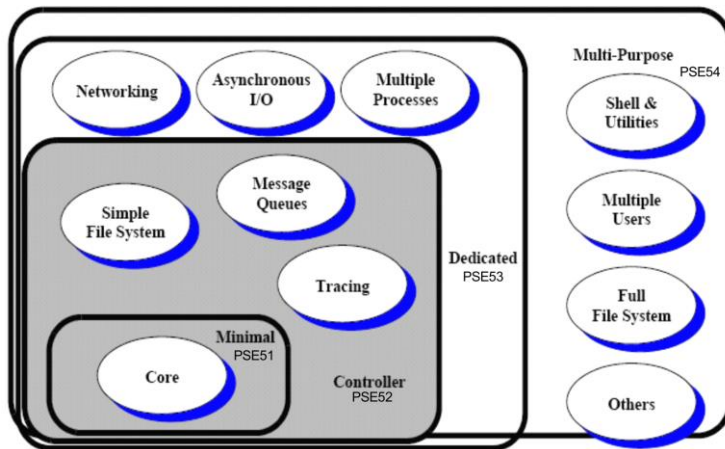

Figure 15: Profile Building Blocks

The profiles are each upwardly compatible and consist of the basic building blocks shown in figure 15, Profile Building Blocks. Each of these profiles has increasing capabilities, which increase requirements on resources. Profiles 51 and 52 runs on a single processor with no Memory Management Unit (MMU), and thus imply a single process containing one or more threads. Profile 52 adds a file system interface and asynchronous I/O. Profile 53 adds support for multiple processes, thus requiring an MMU. The last and largest profile 54 adds support for interactive users and is almost a full POSIX® 1003.1 environment. The higher numbered profiles are supersets of the lower numbered profiles, such that PSE52 includes all the features of a PSE51.

Upward portability between profiles is supported by requiring certain APIs, such as memory locking, for profiles PSE51 and PSE52. Even though there is no MMU support on the PSE51 and PSE52 profiles, code written as if there is an MMU present will be portable among all four profiles by requiring such APIs to be defined in all four profiles. The signature of these APIs will be identical on all profiles, but the functionality will differ according to the capabilities. For example, calling a memory-locking API on a PSE51 platform with no MMU will always return success. When this example application is ported to a PSE53 platform, the memory locking will work as intended without modification to the source code.

Currently, this specification supports platforms based on profiles PSE51 through PSE54, although PSE54 will only be used for development platforms and ground stations. Allowing multiple profiles allows the architecture to scale to different platforms. Applications developed for a specific profile are compatible with higher profiles; that is, a profile 52 application could be ported to profile PSE53 and PSE54 platform, but not vice versa. This upward scalability anticipates that smaller platforms will desire smaller profiles and will not have the resources to run larger applications that comply with the larger profiles.

For Requirements for Operating System Interface

See [12.3.7+12.106, Document STI Interfaces](#) ~~Document STI Interfaces~~.

For POSIX® interfaces this should indicate the supported application profiles as described in standard IEEE 1003.13. For other operating systems or operating system abstraction layers, this should indicate the specific API or abstraction layer and associated version, where applicable.

See [12.107, Document Application's System Library Interfaces-12.3.8, Document Application's System Library Interfaces](#).

Formatted: Default Paragraph Font, Font: 10.5 pt, Font color: Auto, Pattern: Clear

For POSIX® interfaces this should indicate the required application profiles as described in standard IEEE 1003.13. For other operating systems or operating system abstraction layers, this should indicate the specific API or abstraction layer and associated version, where applicable.

Regardless of the POSIX® profile implemented, STI applications should avoid use of any POSIX® function which is not thread safe, to preserve portability of application code to multi-threaded STI platforms. In addition, STI applications should not invoke any function which would cause the parent process to abort or exit (e.g. `exit()` or `abort()`) as these functions may disrupt the operation of other STI applications.

In areas where there is overlap between an STI API and a function provided by POSIX®, such as messages queues and file system access, applications should use the STI provided API.

Table 4 lists a set of common POSIX® functions and the alternative function to use in an STI application. Note that this list only contains a subset of the possible non thread-safe functions and should not be considered exhaustive or complete. Refer to the POSIX® specification for a complete set of non thread-safe functions.

Table 4: Function Alternatives

POSIX® Function(s)	Suggested Alternate
<code>asctime()</code> , <code>ctime()</code>	<code>strftime()</code>
<code>open()</code> , <code>close()</code>	<code>STI FileOpen()</code> , <code>FileClose()</code>
<code>mq_open()</code>	<code>STI MessageQueueCreate()</code>
<code>read()</code> , <code>write()</code>	<code>STI Read()</code> , <code>Write()</code>
<code>strtok()</code>	<code>strtok_r()</code>
<code>rand()</code>	<code>rand_r()</code>
<code>abort()</code> , <code>exit()</code>	<code>STI AbortApp()</code>
<code>ioctl()</code> , <code>mmap()</code>	<code>STI AddressRead()</code> , <code>AddressWrite()</code>
<code>system()</code> , <code>atexit()</code>	None; do not use

Commented [HLM(L9)]: [JIRA issue STI_29: STI Proposal: Change GetCalendarTime to strftime in Table 4](#)

11. External Command and Telemetry Interfaces

An STI radio cannot perform the necessary application and platform functions without an external system providing commands, accepting responses, and monitoring the radio's health and status. The STI radio implements an external interface to receive and act on the commands from the external system, translates the commands into the format expected by the application, and provides the information for monitoring the health and status of the radio. If the STI radio has the capability for new or modified OE, application software, or configurable hardware design, the external command and telemetry interfaces should be able to accept and store new files. The interface in the STI radio and in the external system, which is to provide the control, via a command sequence, to the STI radio and receive responses from an STI radio, is referred to as the STI command and telemetry interfaces. The external STI command and telemetry functionality illustrated in figure 16, Command and Telemetry Interfaces, typically resides on the spacecraft's flight computer, and/or it may reside on a ground station or another spacecraft.

Commented [HLM(L10)]: [JIRA issue STI_5: Correct SysML in figures](#)

Formatted: Default Paragraph Font, Font: 10.5 pt, Font color: Auto, Pattern: Clear

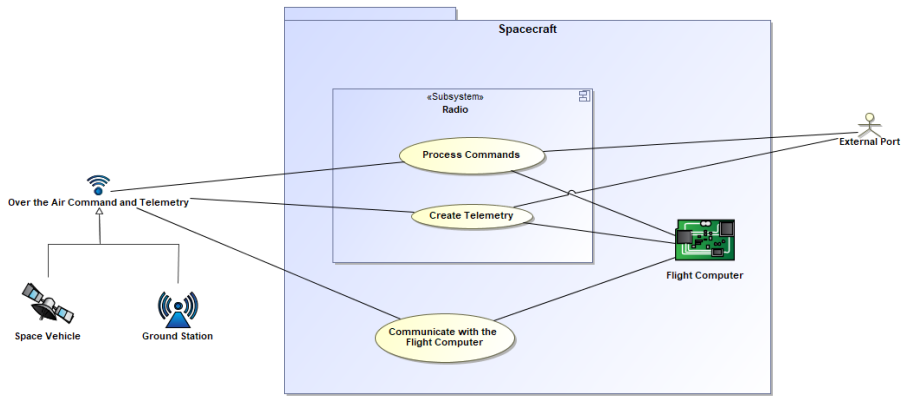

T
R
S
C
T
C
D
I
R
V
B
T

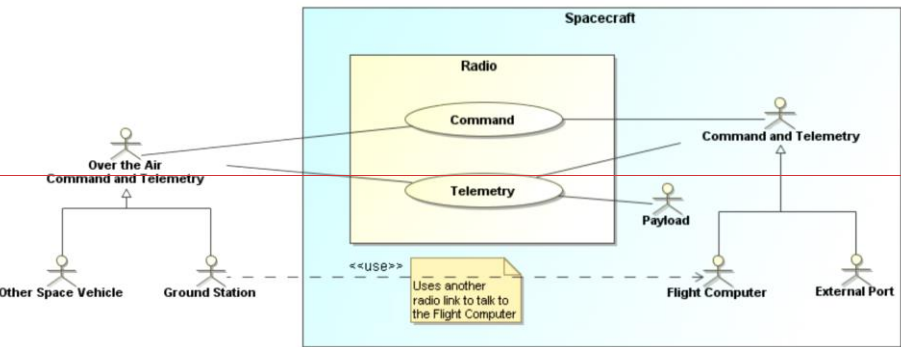

such as MIL-STD-1553, Digital Time Division Command/Response Multiplex Data Bus; command and telemetry interpretation; and translation of the command set to the STI standard necessary for application control. The protocol, command set, and telemetry set for the STI command and telemetry interfaces are *not* standardized and can be customized according to the needs of any particular deployment. However, some interface and behavioral requirements are required.

The telemetry set should contain some or all of the following parameters:

- **Electrical Conditions:** Voltage, current, and power consumption.
- **Environmental Conditions:** Temperature, pressure.
- **Module Configuration:** Module type/location, hardware revision.
- **Self-test Status:** RAM/ROM, file system, software revision, and individual module test status.
- **Operating Environment Status:** Infrastructure software revision, name/ID/state of components, available memory for data and files
- Other Application-specific parameters

The command set may contain some or all of the following actions:

- **Application Instantiation and Deletion:** Manually create or delete a waveform or device.
- **Property Set:** Query or Configure a specific component property via the STI PropertySet API.
- **File Operations:** Query, delete, or rename files via the STI File API.

Formatted: Default Paragraph Font, Font: 10.5 pt, Font color: Auto, Pattern: Clear

- **Invoke Self-tests:** Interface to the STI TestableObject API.
- **Device Operations:** Manually load, flush, or reset a device via the STI Device API.

If the command interface lies on a network containing other devices, the infrastructure should implement some form of command authentication, to reduce the likelihood that commands are received in error or from an unauthorized source. Furthermore, the infrastructure may also implement encryption on the command and telemetry interfaces to ensure that the data is not disclosed to other entities in the system while in transit. Any such security procedures should be implemented at the network transport level, which is outside the scope of this specification.

The specific command or telemetry set available for use is always at the discretion of the system integrator. While the set described here is potentially useful for a development platform, flight operations may choose to use an entirely different set. The use of additional data transmission specification standards is encouraged but not required by this standard

For Requirements for External Command and Telemetry Interfaces

- See [12.8.1+12.108](#), Respond to External Commands
- See [12.8.2+12.109](#), External Commands Use STI API
- See [12.8.3+12.110](#), Document External Commands
- See [12.110-12.8.4, Use STI Query for External Data](#) ~~Document External Commands.~~

12. Normative Requirements

12.1 Hardware

[Document hardware and interfaces.](#)

12.1.1.1 Provide GPM

STI-1 An STI platform shall have a GPM that contains and executes the STI OE and the control portions of the STI applications and services software.

12.1.1.2 Diagnostic Information Availability

STI-2 A module's diagnostic information shall be available via the STI APIs.

12.1.1.3 Document RF

STI-3 The STI platform provider shall describe, in the HID document, the behavior and performance of the RF modular component(s).

12.1.1.4 Document Power-Up State

STI-4 The STI platform provider shall describe, in the HID document, the state of all hardware devices ~~in the system~~ after completion of power-up process.

12.1.1.5 Document Hardware Capability

STI-5 The STI platform provider shall describe, in the HID document, the behavior and capability of each major module or component available for use by a waveform, service, or other application (e.g., FPGA, GPP, DSP, or memory), noting any operational limitations.

Formatted: Text body

Formatted: Heading 3, Indent: Left: 0", First line: 0"

Formatted: Heading 3, Indent: Left: 0", First line: 0"

Formatted: Heading 3, Indent: Left: 0", First line: 0"

Formatted: Heading 3, Indent: Left: 0", First line: 0"

Formatted: Heading 3, Indent: Left: 0", First line: 0"

Formatted: Default Paragraph Font, Font: 10.5 pt, Font color: Auto, Pattern: Clear

12.6 **12.1.6** Document Hardware Limitations

STI-6 The STI platform provider shall describe, in the HID document, the various capabilities, capacities, and any limitations of each reconfigurable component.

Formatted: Heading 3, Indent: Left: 0", First line: 0"

12.7 **12.1.7** Document Interfaces

STI-7 The STI platform provider shall describe, in the HID document, the interfaces that are provided to and from each modular component of the STI platform.

Formatted: Heading 3, Indent: Left: 0", First line: 0"

12.8 **12.1.8** Document the Control and Data Mechanisms

STI-8 The STI platform provider shall describe, in the HID document, the control, telemetry, and data mechanisms of each modular component (i.e., how to program or control each modular component of the platform, and how to use or access each device or software component, noting any proprietary and nonstandard aspects).

Formatted: Heading 3, Indent: Left: 0", First line: 0"

12.9 **12.1.9** Document Power Supply

STI-9 The STI platform provider shall describe, in the HID document, the behavior and performance of any power supply or power converter modular component(s).

Formatted: Heading 3, Indent: Left: 0", First line: 0"

12.10 **12.1.10** Document Thermal and Power Limits

STI-10 The STI platform provider shall describe, in the HID document, the thermal and power limits of the hardware at the smallest modular level to which power is controlled.

Formatted: Heading 3, Indent: Left: 0", First line: 0"

12.11 **12.1.11** Controllable From OE

STI-11 If the STI application has a component resident outside the GPM (e.g., in configurable hardware design), then the component shall be controllable from the STI OE.

Formatted: Heading 3, Indent: Left: 0", First line: 0"

12.2 Configurable Hardware Design

12.12 **12.2.1** Platform Specific Wrapper

STI-12 The STI SPM developer shall provide a platform specific wrapper for each FPGA, which performs the following functions:

1. Provides an interface for command and data from the GPM to the waveform application.
2. Provides the platform-specific pinout for the STI application developer. This may be a complete abstraction of the actual FPGA pinouts with only waveform application signal names provided.

Formatted: Indent: Left: 0", Hanging: 0.81", Outline numbered + Level: 2 + Numbering Style: 1, 2, 3, ... + Start at: 1 + Alignment: Left + Aligned at: 0" + Indent at: 0"

Formatted: Heading 3, Indent: Left: 0", First line: 0"

12.13 **12.2.2** Document FPGA Interfaces

STI-13 The STI SPM developer shall provide documentation on the configurable hardware design interfaces of the platform-specific wrapper for each FPGA, which describes the following:

1. Signal names and descriptions.
2. Signal polarity, format, and data type.
3. Signal direction.
4. Signal-timing constraints.
5. Clock generation and synchronization methods.
6. Signal-registering methods.

Formatted: Heading 3, Indent: Left: 0", First line: 0"

Formatted: Default Paragraph Font, Font: 10.5 pt, Font color: Auto, Pattern: Clear

- 7. Identification of development tool set used.
- 8. Any included non-interface functionality.

12.3 Software

12.1412.3.1 Document System Library Interfaces Provided

STI-14 The STI infrastructure provider shall document the supported system library interface(s) that are provided by the infrastructure, specifying any relevant standards or revisions.

12.1512.3.2 Document System Library Interfaces Used

STI-15 The STI application provider shall document the supported system library interface(s) that are required by the application, specifying any relevant standards or revisions.

12.1612.3.3 Document Language Interfaces Provided

STI-16 The STI infrastructure provider shall document the supported language interface(s) that are provided by the infrastructure, specifying any relevant standards or language revisions.

12.1712.3.4 STI Infrastructure Uses APP API

STI-17 The STI infrastructure shall use the STI Application-provided Application Control Interfaces to control STI applications.

12.1812.3.5 Use Language Specific Facilities Specified in Annex A

STI-18 Applications shall use the respective programming language's designated facilities, such as a package, module, or header file(s), to refer to all STI infrastructure-provided entities as prescribed in Annex A: Language Translations.

12.1912.3.6 Use Language Specific Inheritance

STI-19 Application object definitions shall use the programming language's inheritance mechanisms to specify the set of STI interfaces that are implemented by the application (for object-oriented languages only).

12.3.7 Document STI Interfaces

STI-106 The STI infrastructure provider shall document the set of interfaces provided by the infrastructure.

12.3.8 Document Application's System Library Interfaces

STI-107 The STI application developer shall document the set of operating system interfaces required by the application.

12.4 STI Infrastructure-Provided Software

The following items in section 12.4 are expected to appear in module STI.

12.2012.4.1 STI Infrastructure-Infrastructure-Provided Data Types

STI-20 The STI infrastructure shall define the basic data types as specified in Table 5.

Formatted: Indent: Left: 0", Hanging: 0.81", Outline numbered + Level: 2 + Numbering Style: 1, 2, 3, ... + Start at: 1 + Alignment: Left + Aligned at: 0" + Indent at: 0"

Formatted: Heading 3, Indent: Left: 0", First line: 0"

Formatted: Heading 3, Indent: Left: 0", First line: 0"

Formatted: Heading 3, Indent: Left: 0", First line: 0"

Formatted: Heading 3, Indent: Left: 0", First line: 0"

Formatted: Heading 3, Indent: Left: 0", First line: 0"

Formatted: Heading 3, Indent: Left: 0", First line: 0"

Formatted: Font: (Default) Arial, 12 pt

Commented [HLM(L11)]: Just moved during renumbering to organize requirements into sections

Formatted: Font: (Default) Arial, 14 pt, Bold

Formatted: Font: (Default) Arial, 14 pt, Bold

Formatted: Font: 10.5 pt

Formatted: Heading 3, Indent: Left: 0", First line: 0"

Formatted: Default Paragraph Font, Font: 10.5 pt, Font color: Auto, Pattern: Clear

Table 5: STI Variable Types

N	Type Name	Semantics	Usage/Description
1	Access	Enumeration	Indicates desired access to a file. The specific possible values are described in Table 6.
2	CalendarKind	Enumeration	Identifies a specific method of time representation, such as TAI or UTC. The specific possible values are described in Table 7, CalendarKind ConstantsValues . Because some time representations apply to space, date and time may be defined beyond the ISO standard for Date and Time [8601] on Earth.
3	CalendarTime	Abstract Structure or Class	An abstract object that identifies a specific time for a particular CalendarKind. All possible CalendarTime values are representable as a pointer or reference to this type.
4	FileSize	Integer	Represents a file size in bytes. The variable type should be able to represent the maximum file size among all the filesystems in the system, as well as uniquely identifiable values to indicate error conditions
5	HandleID	Integer	A handle ID is a single value that represents an STI application, device, file, or queue. It may be an index into a table or a pointer to more information for the item. The infrastructure defines the set of valid values for this type.
6	Instance	Structure or Class (base type)	The base type of all application and device context objects. All STI components have a corresponding object of this type stored by the infrastructure, although the object itself is not exposed to other applications.
7	Message	Abstract Structure or Class	The base type of all data exchange (Read, Write) buffers. All STI data exchange messages are representable as a pointer or reference to this type.
8	Nanoseconds	Integer	Indicates the number of nanoseconds (fractional part) within a TimeWarp object. This type can represent at least the range of [0, 999999999], and may be implemented using an “unsigned” value type, if available.
9	Offset	Integer	Indicates an offset from the beginning of a file or device address space. This type has a range capable of representing the last position in the largest file or device in the system. May be implemented using an “unsigned” value type, if available.
10	PropertyName	Integer, Enumeration or String	Identifies properties by name. May be implemented as a numeric enumeration in languages which support this, or as a string value in other environments.
11	PropertyValue	Abstract Structure or Class	The base type of all property values used with the property set interface (Configure, Query). All STI property values are representable as a pointer or reference to this type.

Commented [HLM(L12): [JIRA issue STI_45: STI-20 add index numbers in table](#)

Formatted Table

Commented [HLM(L13): [JIRA issue STI_31: Change “constants” to “predefined values”](#)

Formatted: Default Paragraph Font, Font: 10.5 pt, Font color: Auto, Pattern: Clear

N	Type Name	Semantics	Usage/Description
12	QueueMaxMessages	Integer	Represents the maximum number of messages allowed in a FIFO queue.
13	Result	Integer	Represents a status value, returned by many STI API calls. Specific predefined values represent error conditions, which are distinct from the set of valid results. See constants predefined values defined in Table 9, Result Constants Values .
14	Seconds	Integer	Indicates the number of seconds (whole number part) of a TimeWarp object. Negative values represent time intervals in the past, and positive values indicate time intervals in the future.
15	TestID	Integer	Represents the built-in test or ground test to be performed by APP_RunTest.
16	TimeRate	Integer	Indicates the adjustment factor of clock device clock components during adaptive sync and drift compensation. Positive values represent increased clock frequency/tick rates, negative values represent decreased frequency/tick rates, and a value of zero represents the nominal or "free-run" clock frequency. Units are implementation defined.
17	TimeWarp	Integer or Aggregate value (non-abstract)	The TimeWarp representation of an arbitrary time interval. Logically, this is a single, large value of fixed-point precision. The value should be at least 64 bits in size. If the largest native integer size is less than 64 bits on a given architecture, this may be defined as a structure or array to achieve the necessary range and precision. Units are implementation defined but are convertible to seconds and nanoseconds using the STI methods GetSeconds and GetNanosecondsAPI .

Commented [HLM(L12): JIRA issue STI_45: STI-20 add index numbers in table

Formatted Table

Commented [HLM(L14): JIRA issue STI_31: Change "constants" to "predefined values"

Formatted Table

42.24.12.4.2 Application based on Instance Object

STI-21 The application base object shall be convertible to an Instance object as defined by the STI infrastructure.

Formatted: Heading 3, Indent: Left: 0", First line: 0"

42.22.12.4.3 STI Infrastructure-Provided Access [Constants Values](#)

STI-22 The STI infrastructure shall provide the Access [Constants values](#) as specified in Table 6.

Commented [HLM(L15): JIRA issue STI_31: Change "constants" to "predefined values"

Formatted: Heading 3, Indent: Left: 0", First line: 0"

Table 6: Access [Constants Values](#)

Declaration	enum Access { READ, WRITE, APPEND, BOTH };
Description	Enumerates Enumerate types of access to a file.

Formatted: Default Paragraph Font, Font: 10.5 pt, Font color: Auto, Pattern: Clear

Usage	<ul style="list-style-type: none"> ▶ READ: Indicates file exclusive “read only” permission. ▶ WRITE: Indicates file exclusive “write only” permission, i.e. writing to beginning of file. ▶ APPEND: Indicates file exclusive “append” permission, i.e. writing to end of file. ▶ BOTH: Combination of READ and WRITE permissions.
Provided-By	<code>Infrastructure</code>
Notes	Used exclusively by the <code>FileOpen()</code> API call. See Section 12.7.27 .

Commented [HLM(L16): [JIRA issue STI 33: Remove Unnecessary Table Fields](#)

12.23 12.4.4 STI Infrastructure-Provided_CalendarKind ConstantsValues

STI-23 The STI infrastructure shall provide the CalendarKind [ConstantsValues](#) as specified in Table 7.

Table 7: CalendarKind [ConstantsValues](#)

Declaration	<pre>enum CalendarKind { TAI, UTC, GPS, MJD, LOCALLOCAL_TIME };</pre>
Description	EnumeratesEnumerate several well-defined time and date representations.
Usage	<ul style="list-style-type: none"> ▶ TAI: Corresponds to the International Atomic Time, a monotonically increasing time scale based on the weighted average of numerous Earth-based atomic clocks ▶ UTC: Corresponds to the Coordinated Universal Time, which is offset from TAI by a number of leap seconds that is occasionally updated through international consensus ▶ GPS: Corresponds to the GPS time scale, a count of weeks and seconds since the GPS epoch. Since GPS time does not adjust for leap seconds, it is ahead of UTC by the integer number of leap seconds that have occurred since January 6, 19801980, plus or minus a small number of nanoseconds. ▶ MJD: Corresponds to Modified Julian Date, which is a floating-point representation of Earth days since the MJD epoch:epoch, i.e., the number of days since midnight on November 17, 1858, which corresponds to 2400000.5 days after day 0 of the Julian calendar. MJD is still in common usage in tabulations by the U. S. Naval Observatory. ▶ <code>LOCALLOCAL_TIME</code>: Corresponds to the default local time representation. This is implementation-defined.
Provided-By	<code>Infrastructure</code>
Notes	<p>Platforms do not need to implement every defined calendar system. For those that are implemented, they should be implemented in a manner consistent with the name and specification indicated. Implementations may also define custom CalendarKind values for application-specific needs.</p> <p>Use of the <code>LOCALLOCAL_TIME</code> time and date representation in applications is discouraged, due to the inherent ambiguity. This is intended only for a user interface or display purpose.</p> <p>For more information on the specific time structures associated with these time and date representations, see section 10.6.812.4.14.</p>

Formatted: Heading 3, Indent: Left: 0", First line: 0"

Commented [HLM(L17): [JIRA issue STI 41: local is a reserved word in IDL. change local to localTime and LOCAL to LOCAL_TIME](#)

Commented [HLM(L18): [JIRA issue STI 41: local is a reserved word in IDL. change local to localTime and LOCAL to LOCAL_TIME](#)

Commented [HLM(L19): [JIRA issue STI 33: Remove Unnecessary Table Fields](#)

Formatted Table

Commented [HLM(L20): [JIRA issue STI 41: local is a reserved word in IDL. change local to localTime and LOCAL to LOCAL_TIME](#)

Formatted: Default Paragraph Font, Font: 10.5 pt, Font color: Auto, Pattern: Clear

12.24 12.4.5 STI Infrastructure-Provided_HandleID Constants Values

STI-24 The STI infrastructure shall provide the HandleID Constants values as specified in Table 8.

Table 8: HandleID Constants Values

Declaration <i>(values are examples)</i>	<pre>const HandleID HANDLEID_INVALID = {...};1; const HandleID WARNING_QUEUE = {...};2; const HandleID ERROR_QUEUE = {...};3; const HandleID FATAL_QUEUE = {...};4; const HandleID TELEMETRY_QUEUE = {...};1;</pre>
Description	A set of pre-define predefined values of the HandleID type that will be constant after initialization.
Usage	<ul style="list-style-type: none"> ▶ HANDLEID_INVALID: A reserved value that will never alias a valid handle ID ▶ WARNING_QUEUE: The default queue to use in conjunction with forthe Log() API for context information related to WARNING responses ▶ ERROR_QUEUE: The default queue to use in conjunction with forthe Log() API for context information related to ERROR responses ▶ FATAL_QUEUE: The default queue to use in conjunction with forthe Log() API for context information related to FATAL responses ▶ TELEMETRY_QUEUE: The default queue for general system telemetry data. The purpose and usage of this queue handle is implementation-defined.
Provided By	Infrastructure
Notes	<p>The HANDLEID_INVALID constant value is intended for use as an initializer, to avoid ambiguity in locally instantiated HandleID values. For instance, this can be used within an initializer list in a C++ class constructor, before the member is set to a real handle ID, to avoid potential undefined behavior if the destructor is invoked before the value is set to an actual handle ID.</p> <p><u>The actual queues do not need to be defined as "const" as long as they are defined during initialization of the OE before the need arises to log messages and not changed thereafter.</u></p> <p>Note: <u>If checking return values, a</u>Applications should never check for specifically for the HANDLEID_INVALID value, but rather use the ValidateHandleID () API call.</p>

Formatted: Heading 3, Indent: Left: 0", First line: 0"

Commented [HLM(L21): JIRA issue STI_31: Change "constants" to "predefined values"
JIRA issue STI_51: Add suggested values for ellipses in 12.4

12.25 12.4.6 STI Infrastructure-Provided_Result Constants Values

STI-25 The STI infrastructure shall provide the Result Constants values as specified in Table 9.

Table 9: Result Constants Values

Declaration <i>(values are examples)</i>	<pre>const Result OK = {...};0; const Result WARNING = {...};2; const Result ERROR = {...};3; const Result FATAL = {...};4; const Result UNIMPLEMENTED = {...};5;</pre>
Description	A set of pre-define predefined constant values of the Result type used as return values.

Formatted: Heading 3, Indent: Left: 0", First line: 0"

Commented [HLM(L22): JIRA issue STI_51: Add suggested values for ellipses in 12.4

Commented [HLM(L23): JIRA issue STI_31: Change "constants" to "predefined values"

Formatted: Default Paragraph Font, Font: 10.5 pt, Font color: Auto, Pattern: Clear

Usage	<ul style="list-style-type: none"> ▶ OK: Indicates the operation was successful ▶ WARNING: Indicates the operation was not successful, but little or no corrective action is required. The component is still operational; this may be a transient error. ▶ ERROR: Indicates the operation was not successful, and some corrective action may be required. The component is still operational. ▶ FATAL: Indicates the operation was not successful, and significant corrective action is required. The component is not able to function. ▶ UNIMPLEMENTED: Indicates that the operation itwas not implemented by the component or by the infrastructure.
Provided By:	<u>Infrastructure</u>
Notes	<p>Values other than OK may also indicate success. Applications should never check for this value specifically, but rather use <code>ISOK()</code> to determine if an operation succeeded. An ERROR indicates component is operational, but the request may not be applicable to the component or may not be valid per the current component state. The caller should take action to correct the underlying issue before attempting the call again.</p> <p>The UNIMPLEMENTED value is intended to differentiate between a request that was successfully sent to the target but failed to execute, versus a request that was not sent to the target because it does not implement an optional interface. This may be treated similarly to an ERROR response.</p> <p><u>On error, a corresponding HandleID may be obtained using <code>GetErrorQueue()</code> to use with the <code>Log()</code> API for context information.</u></p>

Commented [HLM(L24): [JIRA issue STI_33: Remove Unnecessary Table Fields](#)

12.2612.4.7 STI Infrastructure-Provided Handle Name Constants Values

STI-26 The STI infrastructure shall provide the Handle Name Constants values as specified in Table 10.

Table 10: Handle Name Constants Values

Declaration (values are examples)	<pre>const string OE_HANDLE_NAME = "<u>STI OE NAME</u>"; const string DEFAULT_CLOCK_NAME = "<u>STI DEFAULT CLOCK</u>";</pre>
Description	A set of pre-define predefined constant handle names.
Usage	<p>OE_HANDLE_NAME: A name identifying the operating environment</p> <p>DEFAULT_CLOCK_NAME: A name identifying the default system clock deviceclock component</p>
Provided By:	<u>Infrastructure</u>
Notes	These names may be passed to <code>HandleRequest()</code> to find the corresponding handle ID, which can then be used to interact with the target component.

Formatted: Heading 3, Indent: Left: 0", First line: 0"

Commented [HLM(L25): [JIRA issue STI_51: Add suggested values for ellipses in 12.4](#)

12.2712.4.8 STI Infrastructure-Provided Property Name Constants Values

STI-27 The STI infrastructure shall provide the Property Name Constants values as specified in Table 11.

Table 11: Property Name Constants Values

Formatted: Heading 3, Indent: Left: 0", First line: 0"

Formatted: Default Paragraph Font, Font: 10.5 pt, Font color: Auto, Pattern: Clear

Declaration <i>(values are examples)</i>	<pre>const PropertyName COMPONENT_PROVIDER = {...}; COMPONENT_PROVIDER"; const PropertyName COMPONENT_VERSION = "COMPONENT_VERSION" {...}; const PropertyName COMPONENT_STATE = "COMPONENT_STATE" {...};</pre>
Description	A set of pre-define predefined property names.
Usage	<ul style="list-style-type: none"> ▶ COMPONENT_PROVIDER: A name associated with the provider of the component. ▶ COMPONENT_VERSION: A name associated with the version of a component. ▶ COMPONENT_STATE: A name associated with the state of a component.
Provided By	Infrastructure
Notes	<p>All applications, as well as the operating environment, will implement these property names. Devices may also implement these property names, but it is not required; for any devices provided by the platform, the values would generally match that of the OE. The values associated with these property names should be free-form strings.</p> <p>The PROVIDER value is usually a company name or university, followed by a subsidiary, division, or department name.</p> <p>The VERSION value is implementation-specific and may be of the format MAJOR.MINOR.REVISION and may also include additional identification information, such as a baseline version control revision ID or tag/branch if relevant.</p> <p>The STATE value is implementation-specific, and the meaning should be indicated by the application developer.</p>

Commented [HLM(L26): JIRA issue STI_51: Add suggested values for ellipses in 12.4

12.2812.4.9 STI Infrastructure-Provided Size Limit Constants Values

STI-28 The STI infrastructure shall provide the Size Limit Constants values as specified in Table 12.

Table 12: Size Limit Constants Values

Declaration <i>(values are examples)</i>	<pre>const Integer MAX_PROPERTY_NAME_SIZE = {...};63; const Integer MAX_PROPERTY_VALUE_SIZE = {...};1023; const Integer MAX_PATH_NAME_SIZE = {...};255; const Integer MAX_HANDLE_NAME_SIZE = {...};63; const Integer MAX_LOG_MESSAGE_SIZE = {...};1023; const MaxQueueMaxMessages MAX_QUEUE_MESSAGES = {...};10;</pre>
Description	Establishes a set of constants predefined values of known maximum size limits for various items.
Usage	<ul style="list-style-type: none"> ▶ MAX_PROPERTY_NAME_SIZE: The maximum size, in bytes, of any PropertyName object ▶ MAX_PROPERTY_VALUE_SIZE: The maximum size, in bytes, of any PropertyValue object ▶ MAX_PATH_NAME_SIZE: The maximum length, in characters, of a file name ▶ MAX_HANDLE_NAME_SIZE: The maximum length, in characters, of a handle name ▶ MAX_LOG_MESSAGE_SIZE: The maximum length, in characters, of strings accepted by the Log () API ▶ MAX_QUEUE_MESSAGES: The maximum number of messages that can be stored in a queue.

Formatted: Heading 3, Indent: Left: 0", First line: 0"

Commented [HLM(L27): - JIRA issue STI_51: Add suggested values for ellipses in 12.4

Formatted: Default Paragraph Font, Font: 10.5 pt, Font color: Auto, Pattern: Clear

Provided-By	Infrastructure
Notes	<p>These <u>constant definitions values</u> are mainly intended for use in languages such as C/C++ where application developers are responsible for buffer allocation. In other languages, buffer allocation may occur automatically and as such these size limits may not be relevant.</p> <p>In C/C++ environments, these <u>constants values</u> will evaluate at compile time, such that they may be used as array dimensions. Note that for string length sizes, the value reflects the maximum number of actual characters in the string and does <i>not</i> take into account any terminating NUL character (<code>\0</code>). The value should always be increased by 1 if the <u>constant value</u> is used in the dimension of a <code>char[]</code> array.</p>

Formatted Table

12.29.12.4.10 STI Infrastructure-Provided TimeWarp Constants Values

STI-29 The STI infrastructure shall provide the TimeWarp Constants values as specified in Table 13.

Table 13: TimeWarp Constants Values

Declaration (values are examples)	<pre>const TimeWarp TIME_INTERVAL_ZERO = {...};0; const TimeWarp TIME_INTERVAL_UNLIMITED = {...};1;</pre>
Description	Constant values suitable for usage with functions accepting a TimeWarp value.
Usage	<ul style="list-style-type: none"> ▶ TIME_INTERVAL_ZERO: Represents the value of zero ▶ TIME_INTERVAL_UNLIMITED: A value indicating no limit to the respective time interval or step size.
Provided-By	Infrastructure
Notes	The TIME_INTERVAL_UNLIMITED <u>constant value</u> is intended be used with functions such as <code>TimeSynch()</code> . When this value is passed as the <code>stepMax</code> argument, it indicates that the infrastructure may directly step the clock to any value.

Formatted: Heading 3, Indent: Left: 0", First line: 0"

Commented [HLM(L28): JIRA issue STI_51: Add suggested values for ellipses in 12.4

12.29.12.4.11 STI Infrastructure-Provided CalendarValueCivil Structure

STI-97 The STI infrastructure shall provide the CalendarValueCivil Structure definition and implementation as specified in Table 14.

Table 14: CalendarValueCivil Structure Definition

Declaration	<pre>struct CalendarValueCivil { long nanoseconds; octet seconds; octet minutes; octet hours; octet day; octet month; short year; };</pre>
--------------------	--

Formatted Table

Formatted: Default Paragraph Font, Font: 10.5 pt, Font color: Auto, Pattern: Clear

Description	<p>Definition of time representation type for the common era / Gregorian calendar.</p> <p>Member Detailsdetails:</p> <ul style="list-style-type: none"> ▶ nanoseconds: The number of nanoseconds, range of [0-999999999] ▶ seconds: The seconds value, range of [0-60] ▶ minutes: The minutes value, range of [0-59] ▶ hours: The hours value, range of [0-23] ▶ day: The day number within the month, range of [0-30] ▶ month: The month number within the year, range of [0-11] ▶ year: The full year number, expressed as an integer (i.e. 2019)
Notes	<p>This format is applicable to UTC and, usually, the local time representations. For local time representations, the specific offset from UTC and daylight savings configuration should be configured or queried separately through the property set interface.</p> <p>The nanoseconds field is intended to support applications that require higher precision time values. This does not imply that the underlying clock has nanosecond precision. For clocks that do not support higher precision timing, this field should always be set as zero.</p>

12.29.212.4.12 STI Infrastructure-Provided CalendarValueGPS Structure

STI-98 The STI infrastructure shall provide the CalendarValueGPS Structure definition and implementation as specified in Table 15.

Table 15: CalendarValueGPS Structure Definition

Declaration	<pre>struct CalendarValueGPS { long tow; short week; };</pre>
Description	<p>Definition of time representation expressed in weeks and seconds, similar to the style used in GPS navigation messages. Member details:</p> <ul style="list-style-type: none"> ▶ tow: The time of week in milliseconds, range of [0-604799999] ▶ week: The number of weeks elapsed since the epoch
Member-Details	<ul style="list-style-type: none"> ▶ tow: The time of week in milliseconds, range of [0-604799999] ▶ week: The number of weeks elapsed since the epoch
Notes	<p>This is not an exact representation of GPS time codes, but rather a method of expressing time in terms that facilitate easy conversion to/from actual GPS navigation code formats while also providing higher precision.</p> <p>Legacy GPS navigation signals express the week number as a 10-bit integer, which rolls over every 1024 weeks, with time of week expressed as a 19-bit integer with 1.5 second resolution. Other navigation signals have a different format, using 13-bit week number along with a 2-hour interval time of week and 18-second time of interval.</p> <p>This structure expresses the time of week value in units of milliseconds. Conversion from legacy GPS time of week values is accomplished via multiplication by 1500 (1.5 seconds), and conversion from 18-second time of interval codes is accomplished via multiplication by 18000. Likewise, a conversion to whole seconds can be achieved by dividing the tow by 1000, and the day of week can be determined by dividing by 86400000.</p>

Formatted: Table List, Outline numbered + Level: 1 + Numbering Style: Bullet + Aligned at: 0" + Indent at: 0.15"

Commented [HLM(L29): [JIRA issue STI 47: Merge table fields Member details into Description](#)

Formatted: Default Paragraph Font, Font: 10.5 pt, Font color: Auto, Pattern: Clear

12.29.312.4.13 STI Infrastructure-Provided CalendarValueDayNumber Structure

STI-99 The STI infrastructure shall provide the CalendarValueDayNumber Structure definition and implementation as specified in Table 16.

Table 16: CalendarValueDayNumber Structure Definition

Declaration	struct CalendarValueDayNumber { double date; };
Description	Definition of time representation expressed as a fractional day number. <u>Member details:</u> ▶ <u>date: The day number expressed as a fractional / floating point value</u>
Member Details	▶ <u>date: The day number expressed as a fractional / floating point value</u>
Notes	The whole number (integer portion) of the value expresses the number of Earth days since the epoch, and the fractional part expresses the time of day.

Formatted: Table List, Outline numbered + Level: 1 + Numbering Style: Bullet + Aligned at: 0" + Indent at: 0.15"

Commented [HLM(L30): JIRA issue STI_47: Merge table fields Member details into Description]

12.29.412.4.14 STI Infrastructure-Provided CalendarTime Union

STI-100 The STI infrastructure shall provide the CalendarTime Union definition and implementation as specified in Table 17.

Table 17: CalendarTime Union Definition

Declaration	union CalendarTime switch(CalendarKind) { case MJD: CalendarValueDayNumber dayNumber; case GPS: CalendarValueGPS weekSeconds; case <u>LOCALLOCAL_TIME</u> : CalendarValueCivil <u>localTimeHere</u> ; case TAI: CalendarValueCivil tai; case UTC: CalendarValueCivil civil; };
Description	Definition of CalendarTime type based on CalendarKind value.
Notes	

Commented [HLM(L31): JIRA issue STI_27: STI-100: CalendarValueWeekSeconds is undefined]

Commented [HLM(L32): JIRA issue STI_41: local is a reserved word in IDL, change local to localTime and LOCALLOCAL to LOCAL_TIME]

12.30

Formatted: Normal

12.3412.5 STI Application-Application-Provided Methods

“Provide a definition” implies supplying a consistent interface, which may be used or inherited by other methods. The implementation of such an interface may be supplied by others. For functions, an abstract method or class, a virtual method, or prototype is usually supplied.

Any apparent discrepancy between application-provided and infrastructure-provided of the titles and requirements is easily resolved by noting that the infrastructure provides the definition while the application inherits an implementation or provides the implementation directly.

Formatted: Normal

Commented [HLM(L33): JIRA issue STI_35: Add extra introductory remarks to 12.5, 12.6, and 12.7. JIRA issue STI_37: Clarify definition vs implementation]

12.3212.5.1 STI Infrastructure-Provided APP_GetHandleID Method

STI-30 The STI infrastructure shall provide the APP_GetHandleID(~~Definition()~~-definition and implementation as specified in ~~Table 14~~Table 18.

Formatted: Heading 3, Indent: Left: 0", First line: 0"

Formatted: Default Paragraph Font, Font: 10.5 pt, Font color: Auto, Pattern: Clear

Table 1418: APP_GetHandleID() Definition

Declaration	interface Instance { HandleID APP_GetHandleID(); };
Description	Obtain the handle ID for the application, stored by the STI Infrastructure.
Return	The actual handle ID of the calling application, or an invalid handle ID on failure or predefined HANDLEID_INVALID on failure
Implemented By	Infrastructure
Invoked By	Application
Notes	This call should never fail when invoked from a normal, fully constructed application or device context. If invoked from an application or device context that is not fully constructed, an invalid ID may be returned. Specifically, this condition may occur while the constructor or destructor are currently executing (see section 10.5.2.1). If the infrastructure cannot obtain the correct handle ID, the infrastructure will return a value such as HANDLEID_INVALID that does not alias a valid handle ID. The caller should always validate the returned handle ID using ValidateHandleID() to determine success or failure.

Formatted: Border: Top: (No border), Bottom: (No border), Left: (No border), Right: (No border)

Commented [HLM(L34): JIRA issue STI_33: Remove Unnecessary Table Fields

12.3312.5.2 STI Infrastructure-Provided APP_GetHandleName Method

STI-31 The STI infrastructure shall provide the APP_GetHandleName() Definition() definition and implementation as specified in Table 1514.

Table 1514: APP_GetHandleName() Definition

Declaration	interface Instance { string Result APP_GetHandleName(out string handleName); };
Description	Obtain the name for the application, stored by the STI Infrastructure.
Parameters	▶ handleName: A string representing the handle name of the called STI application
Return	On success, return the predefined Result value OK; otherwise, return one of the predefined Result values indicating failure. See 12.4.6 STI Infrastructure-Provided Result Values. The name of the calling application, or a NULL/undefined value on failure
Implemented By	Infrastructure
Invoked By	Application
Notes	The caller is responsible for preallocating the size of handleName to [MAX_HANDLE_NAME_SIZE+1]. This call should never fail when invoked from a normal, fully constructed application or device context. If invoked from an application or device context that is not fully constructed, this call may fail. Specifically, this condition may occur while the constructor or destructor are currently executing (see section 10.5.2.1). If the infrastructure cannot obtain the correct handle name, the infrastructure will return a value that does not alias a valid handle name, such as NULL in C/C++ or the corresponding undefined value representation in other languages.

Formatted: Heading 3, Indent: Left: 0", First line: 0"

Formatted: Border: Top: (No border), Bottom: (No border), Left: (No border), Right: (No border)

Formatted: Font: (Default) Courier New

Formatted: Default, Indent: Left: 0.02", Right: 0.5", Bulleted + Level: 1 + Aligned at: 0.25" + Indent at:

Commented [HLM(L35): JIRA issue STI_15: STI-16: There are items in the calling sequence but the parameters are not described

Formatted: Default Paragraph Font, Font: 10.5 pt, Font color: Auto, Pattern: Clear

12.3412.5.3 STI Application-Provided APP_Instance Method

STI-32 The STI infrastructure shall provide the APP_Instance() ~~Definition~~ definition as specified in ~~Table 16~~Table 20.

Table 1620: APP_Instance() Definition

Declaration	<code>interface ApplicationControl : Lifecycle, PropertySet, ControllableComponent, TestableObject, Instance { __Instance APP_Instance(in HandleID id, in string name __); };</code>
Description	Construct an instance of the application, identified by the id and name indicated in the parameters.
Parameters	<ul style="list-style-type: none"> ▶ id: The handle ID of this STRS-STI application. ▶ name: The handle name of this STRS-STI application.
Return	On success, return a reference to the constructed instance. On failure, return an invalid reference (i.e. NULL in C/C++, or the respective undefined value in other languages)
Implemented By	Application
Invoked By	Infrastructure
Notes	<p>The id and name values passed to this constructor become valid only <i>after</i> the constructor has completed successfully and returned a valid object reference/pointer. As such, other infrastructure calls should not be invoked from the constructor using these values. Use of the values during the construction of the object itself is not defined, as the infrastructure may still consider it an invalid ID or name.</p> <p>For statically allocated objects, a pointer to the pre-allocated structure may be returned, without performing any additional allocation.</p> <p>In all cases, the object returned will be of the Instance type, either directly or as a derivative type. In object-oriented languages, the instance object will inherit from the correct base object or class. In C, this can be done by ensuring the first member of the returned structure object is an Instance object as defined by the infrastructure.</p>

Formatted: Heading 3, Indent: Left: 0", First line: 0"

Formatted: Border: Top: (No border), Bottom: (No border), Left: (No border), Right: (No border)

Commented [HLM(L36): JIRA issue STI 49: Add inheritance to APP and DEV Declarations

12.3512.5.4 STI Application-Provided APP_Destroy Method

STI-33 The STI infrastructure shall provide the APP_Destroy() ~~Definition~~ definition as specified in ~~Table 17~~Table 21.

Table 1721: APP_Destroy() Definition

Declaration	<code>interface ApplicationControl : Lifecycle, PropertySet, ControllableComponent, TestableObject, Instance { __void APP_Destroy(in Instance inst __); };</code>
--------------------	--

Formatted: Heading 3, Indent: Left: 0", First line: 0"

Formatted: Border: Top: (No border), Bottom: (No border), Left: (No border), Right: (No border)

Commented [HLM(L37): JIRA issue STI 49: Add inheritance to APP and DEV Declarations

Formatted: Default Paragraph Font, Font: 10.5 pt, Font color: Auto, Pattern: Clear

Description	Delete an instance of the application, identified by the <code>inst</code> parameter.
Parameters	► <code>inst</code> : pointer to application instance.
Return	None
Implemented By	Application
Invoked By	Infrastructure
Notes	This function will be defined but may be empty or a “no-op” for statically allocated entities. After this call completes, the object referred to by the <code>inst</code> parameter is considered invalid, and the infrastructure ensures that any internally stored references to the instance have been deleted.

12.3612.5.5 STI Application-Provided APP_Initialize Method

STI-34 The STI infrastructure shall provide the `APP_Initialize()` ~~Definition- definition~~ as specified in ~~Table 48~~Table 22 to be implemented by an STI application or device.

Table 4822: APP_Initialize() Definition

Declaration	interface ApplicationControlLifeCycle { Result APP_Initialize(); };
Description	Initialize the application. Obtain any underlying system resources as required for further operation and set all internal variables to a known initial state.
Return	On success, return the predefined Result value OK; otherwise, return one of the predefined Result values indicating failure. See 12.4.6 STI Infrastructure-Provided Result Values, Status-code which the caller should validate using ISOK (-). On failure, returns one of the defined Result error constants. On success, return the status-code OK.
Implemented By	Application
Invoked By	Infrastructure
Notes	If initialization is unsuccessful for any reason, the implementation will ensure that any external system resources obtained before the failure are returned to their original state. There is no provision to permit “partial” initialization sequences to occur. If not successful, the implementation should log details of the failure to the log facility.

Formatted: Heading 3, Indent: Left: 0", First line: 0"

Formatted: Border: Top: (No border), Bottom: (No border), Left: (No border), Right: (No border)

12.3712.5.6 STI Application-Provided APP_ReleaseObject Method

STI-35 The STI infrastructure shall provide the `APP_ReleaseObject()` ~~Definition- definition~~ as specified in ~~Table 49~~Table 23 to be implemented by an STI application or device.

Table 4923: APP_ReleaseObject() Definition

Declaration	interface ApplicationControlLifeCycle { Result APP_ReleaseObject(); };
--------------------	---

Formatted: Heading 3, Indent: Left: 0", First line: 0"

Formatted: Border: Top: (No border), Bottom: (No border), Left: (No border), Right: (No border)

Formatted: Default Paragraph Font, Font: 10.5 pt, Font color: Auto, Pattern: Clear

Description	Release any system resources that were obtained during the initialization or normal operation.
Return	On success, return the predefined Result value OK; otherwise, return one of the predefined Result values indicating failure. See 12.4.6 STI Infrastructure-Provided Result Values, Status code which the caller should validate using ISOK(). On failure, returns one of the defined Result error constants. On success, return the status code OK.
Implemented-By	Application
Invoked-By	Infrastructure
Notes	This operation should be the inverse of the APP_Initialize() operation, returning the application or device to the same state as it was prior to initialization. After this operation, the infrastructure will either destroy the instance or initialize it again.

12.3812.5.7 STI Application-Provided APP_Query Method

STI-36 The STI infrastructure shall provide the APP_Query() ~~Definition- definition~~ as specified in ~~Table 20~~Table 24 to be implemented by an STI application or device.

Table 2024: APP_Query() Definition

Declaration	interface ApplicationControlPropertySet { Result APP_Query(in PropertyName propName, out PropertyValue propValue); };
Description	Obtain or “get” the value for one property in the component.
Parameters	▶ propName: The name or identifier of the property to get ▶ propValue: A buffer to store the property value
Return	On success, return the predefined Result value OK, which indicates that the property value has been retrieved in its entirety; otherwise, return one of the predefined Result values indicating failure. See 12.4.6 STI Infrastructure-Provided Result Values, Status code which the caller should validate using ISOK(). On failure, returns one of the defined Result error constants. The status code OK indicates that the property value has been retrieved in its entirety.
Implemented-By	Application
Invoked-By	Infrastructure

Formatted: Heading 3, Indent: Left: 0", First line: 0"

Formatted: Border: Top: (No border), Bottom: (No border), Left: (No border), Right: (No border)

Formatted: Font: 10.5 pt

Formatted: Default Paragraph Font, Font: 10.5 pt, Font color: Auto, Pattern: Clear

Notes	<p>If an error is returned by an implementation, a corresponding message indicating details of the failure should be written to the log facility for diagnostic purposes.</p> <p>Return status-codesResult values other than the predefined status-Result constantsvalues are permissible for backward compatibility but are to be validated using the <code>IsOK()</code> function. Use of additional codes-return values are is-not recommended for new software; for maximum portability, custom status-codesreturn values or “partial success” return codes should be avoided.</p> <p>For C/C++ implementations, the abstract <code>propValue</code> parameter is translated to two parameters, a base object pointer and size.</p>
--------------	--

12.3912.5.8 STI Application-Provided APP_Configure Method

STI-37 The STI infrastructure shall provide the `APP_Configure()` ~~Definition- definition~~ as specified in ~~Table 24~~**Table 25** to be implemented by an STI application or device.

Table ~~24~~**25**: `APP_Configure()` Definition

Declaration	<pre>interface ApplicationControlPropertySet { Result APP_Configure(in PropertyName propName, in PropertyValue propValue); };</pre>
Description	Configure or "set" the value for one property in the component.
Parameters	<ul style="list-style-type: none"> ▶ <code>propName</code>: The name of the property to set ▶ <code>propValue</code>: The value to set the property to
Return	<p>On success, return the predefined Result value OK, which indicates that the property value has been configured; otherwise, return one of the predefined Result values indicating failure. See 12.4.6 STI Infrastructure-Provided Result Values. Status code which the caller should validate using IsOK().</p> <p>On failure, returns one of the defined Result error constants. The status code OK indicates that the property value has been configured.</p>
Implemented By	Application
Invoked By	Infrastructure
Notes	<p>If an error is returned by an implementation, a corresponding message indicating details of the failure should be written to the log facility for diagnostic purposes.</p> <p>Status-codesReturn Result values (other than the predefined status-Result constantsvalues) are permissible for backward compatibility but are to be validated using the <code>IsOK()</code> function. ThisUse of additional return Result values This is not recommended for new software; for maximum portability, custom status-codesResult values or “partial success” return codes should be avoided.</p> <p>For C/C++ implementations, the abstract <code>propValue</code> parameter is translated to two parameters, a base object pointer and size.</p>

Formatted: Heading 3, Indent: Left: 0", First line: 0"

Formatted: Border: Top: (No border), Bottom: (No border), Left: (No border), Right: (No border)

Formatted: Font: 10.5 pt

Formatted Table

Formatted: Default Paragraph Font, Font: 10.5 pt, Font color: Auto, Pattern: Clear

12.4012.5.9 STI Application-Provided APP_RunTest Method

STI-38 The STI infrastructure shall provide the APP_RunTest() ~~Definition~~ definition as specified in ~~Table 22~~Table 26 to be implemented by an STI application or device.

Table 2226: APP_RunTest() Definition

Declaration	interface ApplicationControl TestableObject { Result APP_RunTest(in TestID testID); };
Description	Invokes the test of the target application as indicated by the test ID.
Parameters	► testID: the ID of the test to be performed. Values of testID are mission dependent.
Return	On success or if the test is running in the background, return the predefined Result value OK; otherwise, return one of the predefined Result values indicating failure. See 12.4.6 STI Infrastructure-Provided Result Values, Status-code which the caller should validate using ISOK(). On error, returns one of the defined Result error constants. A successful result (status-code OK) indicates that the test is successful or that the test is running in the background.
Implemented-By	Application
Invoked-By	Infrastructure
Notes	Tests which are not appropriate for a given system state, such as invoking a ground-specific test while in a flight operation mode, should generate an error status return and record the issue in the system log.

Formatted: Heading 3, Indent: Left: 0", First line: 0"

Formatted: Border: Top: (No border), Bottom: (No border), Left: (No border), Right: (No border)

12.4412.5.10 STI Application-Provided APP_Start Method

STI-39 The STI infrastructure shall provide the APP_Start() ~~Definition~~ definition as specified in ~~Table 23~~Table 27 to be implemented by an STI application or device.

Table 2327: APP_Start() Definition

Declaration	interface ApplicationControl ControllableComponent { Result APP_Start(); };
Description	Begin normal target component (application or device) processing.
Return	On success, return the predefined Result value OK; otherwise, return one of the predefined Result values indicating failure. See 12.4.6 STI Infrastructure-Provided Result Values, Status-code which the caller should validate using ISOK(). On error, returns one of the defined Result error constants. On success, return the status-code OK.
Implemented-By	Application
Invoked-By	Infrastructure

Formatted: Heading 3, Indent: Left: 0", First line: 0"

Formatted: Border: Top: (No border), Bottom: (No border), Left: (No border), Right: (No border)

Formatted Table

Formatted: Default Paragraph Font, Font: 10.5 pt, Font color: Auto, Pattern: Clear

Notes	If the application is not in the appropriate internal state, then nothing is done and an error is returned. If an error is returned by an implementation, a corresponding message to indicate details of the failure should be written to the log facility for diagnostic purposes.
--------------	--

12.4.212.5.11 STI Application-Provided APP_Stop Method

STI-40 The STI infrastructure shall provide the APP_Stop() ~~Definition-~~ definition as specified in ~~Table 24~~Table 28 to be implemented by an STI application or device.

Table 2428: APP_Stop() Definition

Declaration	interface ApplicationControlControllableComponent { Result APP_Stop(); };
Description	End normal target component (application or device) processing.
Return	On success, return the predefined Result value OK; otherwise, return one of the predefined Result values indicating failure. See 12.4.6 STI Infrastructure-Provided Result Values, Status code which the caller should validate using ISOK(). On error, returns one of the defined Result error constants. On success, return status code OK.
Implemented By	Application
Invoked By	Infrastructure
Notes	If the application is not in the appropriate internal state, then nothing is done and an error is returned. If an error is returned by an implementation, a corresponding message to indicate details of the failure should be written to the log facility for diagnostic purposes.

Formatted: Heading 3, Indent: Left: 0", First line: 0"

Formatted: Border: Top: (No border), Bottom: (No border), Left: (No border), Right: (No border)

12.5.12 STI Application-Provided APP_Read Method

STI-47 The STI infrastructure shall provide the APP_Read() definition as specified in Table 29 to be implemented as needed, by an STI application or device.

Table 29: APP_Read() Definition

Declaration	interface Source { Result APP_Read(out Message buffer); };
Description	The buffer is filled with data from the component.
Parameters	► <i>buffer</i> : a storage area for data transferred from the target
Return	On success, the return value indicates the number of units of data (records or bytes) actually obtained from the application or device, which may be less than the complete buffer size. Otherwise, return one of the predefined Result values indicating failure. See 12.4.6 STI Infrastructure-Provided Result Values.

Formatted: Border: Top: (No border), Bottom: (No border), Left: (No border), Right: (No border)

Formatted Table

Formatted: Default Paragraph Font, Font: 10.5 pt, Font color: Auto, Pattern: Clear

Notes	<p>The actual storage for the buffer is allocated by the caller or infrastructure prior to invoking this function. The application should fill the buffer to the maximum extent possible and return the amount of buffer actually filled.</p> <p>The application developer defines the specific format and units for the buffer. In languages with direct memory access (e.g. C), it may be an arbitrary memory buffer with the units specified in bytes. In other languages, the units should reflect logical records, such as a number of characters, samples, or objects.</p> <p>The infrastructure makes no assumptions about the format of the message data, nor the presence or expectation of a terminating entity, such as a NUL character ('\0') as required for C-style strings. If a terminating character is required, the caller will ensure that sufficient space is available in the buffer to store the termination character.</p> <p>If an error is returned by an implementation, a corresponding message to indicate details of the failure should be written to the log facility for diagnostic purposes.</p> <p>For C/C++ implementations, the abstract <code>buffer</code> parameter is translated to two parameters, a base object pointer and size.</p>
--------------	---

12.5.13 STI Application-Provided APP_Write Method

STI-48 The STI infrastructure shall provide the APP_Write() definition as specified in Table 30 to be implemented, as needed, by an STI application or device.

Table 30: APP_Write() Definition

Declaration	<pre>interface Sink { Result APP_Write(in Message buffer); };</pre>
Description	The buffer data is sent to the target component.
Parameters	► <code>buffer</code> : an abstract data set that should be transferred to the target
Return	On success, the return value indicates the number of units of data (records or bytes) actually sent to the application or device, which may be less than the buffer size. Otherwise, return one of the predefined Result values indicating failure. See 12.4.6 STI Infrastructure-Provided Result Values.
Notes	<p>The actual storage for the buffer is allocated and filled by the caller or infrastructure prior to invoking this function. The application should transfer the data to the maximum extent possible and return the amount of buffer actually transferred to the device.</p> <p>The application developer defines the specific format and units for the buffer. In languages with direct memory access (e.g. C), it may be an arbitrary memory buffer with the units specified in bytes. In other languages, the units should reflect logical records, such as a number of characters, samples, or objects.</p> <p>The infrastructure makes no assumptions about the format of the message data, nor the presence or expectation of a terminating entity, such as a NUL character ('\0') as required for C-style strings. If a terminating character is required, the caller will ensure that it has been added to the buffer prior to invoking this operation.</p> <p>If an error is returned by an implementation, a corresponding message to indicate details of the failure should be written to the log facility for diagnostic purposes.</p> <p>For C/C++ implementations, the abstract <code>buffer</code> parameter is translated to two parameters, a base object pointer and size.</p>

Formatted: Border: Top: (No border), Bottom: (No border), Left: (No border), Right: (No border)

Formatted: Default Paragraph Font, Font: 10.5 pt, Font color: Auto, Pattern: Clear

12.5.14 STI Application-Provided APP AddressRead Method

STI-49 The STI infrastructure shall provide the APP_AddressRead() definition as specified in Table 31 to be implemented, as needed, by an STI application or device.

Table 31: APP_AddressRead() Definition

Declaration	<pre>interface RandomAccess { _____ Result _____ APP_AddressRead(_____ in Offset offset, _____ out Message buffer _____); };</pre>
Description	The buffer is filled with data from the component at the specified location.
Parameters	<ul style="list-style-type: none"> ▶ <u>offset</u>: the location to read data from ▶ <u>buffer</u>: a storage area for data transferred from the target
Return	On success, the return value indicates the number of units of data (defined by the platform developer) actually obtained from the application or device, which may be less than the complete buffer size. Otherwise, return one of the predefined Result values indicating failure. See 12.4.6 STI Infrastructure-Provided Result Values.
Notes	<p>The actual storage for the buffer is allocated by the caller or infrastructure prior to invoking this function. The application should fill the buffer to the maximum extent possible and return the amount of buffer actually filled.</p> <p>The application developer defines the specific format and units for the buffer. In languages with direct memory access (e.g. C), it may be an arbitrary memory buffer with the units specified in bytes. In other languages, the units should reflect logical records, such as a number of characters, samples, or objects.</p> <p>The infrastructure makes no assumptions about the format of the message data, nor the presence or expectation of a terminating entity, such as a NUL character ('\0') as required for C-style strings. If a terminating character is required, the caller will ensure that sufficient space is available in the buffer to store the termination character.</p> <p>If an error is returned by an implementation, a corresponding message to indicate details of the failure should be written to the log facility for diagnostic purposes.</p> <p>For C/C++ implementations, the abstract <u>buffer</u> parameter is translated to two parameters, a base object pointer and size.</p>

Formatted: Border: Top: (No border), Bottom: (No border), Left: (No border), Right: (No border)

12.5.15 STI Application-Provided APP AddressWrite Method

STI-50 The STI infrastructure shall provide the APP_AddressWrite() definition as specified in Table 32 to be implemented, as needed, by an STI application or device.

Table 32: APP_AddressWrite() Definition

Declaration	<pre>interface RandomAccess { _____ Result _____ APP_AddressWrite(_____ in Offset offset, _____ in Message buffer _____); };</pre>
Description	The buffer data is written to the target component at the specified location.

Formatted: Border: Top: (No border), Bottom: (No border), Left: (No border), Right: (No border)

Formatted: Default Paragraph Font, Font: 10.5 pt, Font color: Auto, Pattern: Clear

Parameters	<ul style="list-style-type: none"> ▶ <code>offset</code>: the location to write the data ▶ <code>buffer</code>: an abstract data set that should be transferred to the target
Return	On success, the return value indicates the number of units of data (records or bytes) actually sent to the application or device, which may be less than the buffer size. Otherwise, return one of the predefined Result values indicating failure. See 12.4.6 STI Infrastructure-Provided Result Values.
Notes	<p>The actual storage for the buffer is allocated and filled by the caller or infrastructure prior to invoking this function. The application should transfer the data to the maximum extent possible and return the amount of buffer actually transferred to the device.</p> <p>The application developer defines the specific format and units for the buffer. In languages with direct memory access (e.g. C), it may be an arbitrary memory buffer with the units specified in bytes. In other languages, the units should reflect logical records, such as a number of characters, samples, or objects.</p> <p>The infrastructure makes no assumptions about the format of the message data, nor the presence or expectation of a terminating entity, such as a NUL character ('\0') as required for C-style strings. If a terminating character is required, the caller will ensure that it has been added to the buffer prior to invoking this operation.</p> <p>If an error is returned by an implementation, a corresponding message to indicate details of the failure should be written to the log facility for diagnostic purposes.</p> <p>For C/C++ implementations, the abstract <code>buffer</code> parameter is translated to two parameters, a base object pointer and size.</p>

Formatted Table

12.6 STI Device-Provided Methods

“Provide a definition” implies supplying a consistent interface, which may be used or inherited by other methods. The implementation of such an interface may be supplied by others. For functions, an abstract method or class, a virtual method, or prototype is usually supplied.

Formatted: Normal, Indent: Left: 0", First line: 0"

Formatted: Font: 14 pt

Formatted: Font: 14 pt

Any apparent discrepancy between device-provided and infrastructure-provided of the titles and requirements is easily resolved by noting that the infrastructure provides the definition while the device inherits an implementation or provides the implementation directly.

Formatted: Normal

Commented [HLM(L38): JIRA issue STI_35: Add extra introductory remarks to 12.5, 12.6, and 12.7. JIRA issue STI_37: Clarify definition vs implementation]

12.4.3 12.6.1 STI Device-Provided DEV_Open Method

STI-41 The STI infrastructure shall provide the DEV_Open() ~~Definition-~~ definition as specified in Table 25 Table 33 to be implemented by an STI device.

Formatted: Font: 12 pt

Formatted: Heading 3, Indent: Left: 0", First line: 0"

Table 25 Table 33: DEV_Open() Definition

Declaration	interface DeviceControl : ApplicationControl { Result DEV_Open(); };
Description	Open the device for command and control.
Return	On success, return the predefined Result value OK; otherwise, return one of the predefined Result values indicating failure. See 12.4.6 STI Infrastructure-Provided Result Values. On error, returns one of the defined Result error constants. On success, return status code OK.
Implemented By	Device or Platform Provider

Commented [HLM(L39): JIRA issue STI_49: Add inheritance to APP and DEV Declarations]

Formatted: Border: Top: (No border), Bottom: (No border), Left: (No border), Right: (No border)

Formatted: Default Paragraph Font, Font: 10.5 pt, Font color: Auto, Pattern: Clear

Invoked-By	Infrastructure
Notes	The implementation should obtain whatever operating system or HAL resources are necessary to initiate communication or data transfer with the hardware device. Depending on the underlying device and operating system driver infrastructure, use of a hardware device may be limited to one process at a time, so a successful call to this function may prevent other processes in the system from using the device. Likewise, if another process is using the device, or the device is otherwise not able to accept control requests, this operation may fail or block until the device becomes available. If no specific operating system resources are required for communication with the device, this implementation may be a no-op. In this case, this operation should return the predefined Result value OK to maintain compatibility.

Formatted Table

12.44 12.6.2 STI Device-Provided DEV_Load Method

STI-42 The STI infrastructure shall provide the DEV_Load() ~~Definition- definition~~ as specified in ~~Table 26~~Table 34 to be implemented by an STI device.

Table 2634: DEV_Load() Definition

Declaration	interface DeviceControl : ApplicationControl { Result DEV_Load(in string fileName); };
Description	Load a binary application image or configuration file to the device.
Parameters	► fileName: name of the image or configuration file to load to the device
Return	On success, return the predefined Result value OK; otherwise, return one of the predefined Result values indicating failure. See 12.4.6 STI Infrastructure-Provided Result Values. On error, returns one of the defined Result error constants. On success, return status code OK.
Implemented-By	Device or Platform Provider
Invoked-By	Infrastructure
Notes	If the device is an FPGA, this operation would load a specific hardware design image to the device. If the device represents a microcontroller or DSP, this should load a firmware or application image to the device.

Formatted: Font: 14 pt

Formatted: Heading 2, Indent: Left: 0.81"

Formatted: Heading 3, Indent: Left: 0", First line: 0"

Formatted: Border: Top: (No border), Bottom: (No border), Left: (No border), Right: (No border)

12.45 12.6.3 STI Device-Provided DEV_Reset Method

STI-43 The STI infrastructure shall provide the DEV_Reset() ~~Definition- definition~~ as specified in ~~Table 27~~Table 35 to be implemented by an STI device.

Table 2735: DEV_Reset() Definition

Declaration	interface DeviceControl : ApplicationControl { Result DEV_Reset(); };
Description	Initialize a device to a known state.

Formatted: Heading 3, Indent: Left: 0", First line: 0"

Formatted: Border: Top: (No border), Bottom: (No border), Left: (No border), Right: (No border)

Formatted: Default Paragraph Font, Font: 10.5 pt, Font color: Auto, Pattern: Clear

Return	<u>On success, return the predefined Result value OK; otherwise, return one of the predefined Result values indicating failure. See 12.4.6 STI Infrastructure-Provided Result Values.</u> On error, returns one of the defined Result error constants. On success, return status code OK.
Implemented By	Device or Platform Provider
Invoked By	Infrastructure
Notes	This operation should bring a device into a known clean state, if possible. This operation may utilize a hardware reset function if available, or it may reconfigure all internal registers to a known initial value. This function should not “unload” programming information from an FPGA device. If a hardware reset function is used and this clears the programming information, the implementation should ensure that previously loaded image is restored before returning.

12.4612.6.4 STI Device-Provided DEV_Flush Method

STI-44 The STI infrastructure shall provide the DEV_Flush()~~Definition- definition~~ as specified in ~~Table 28~~Table 36 to be implemented by an STI device.

Table 2836: DEV_Flush() Definition

Declaration	interface DeviceControl : <u>ApplicationControl</u> { Result DEV_Flush(); };
Description	Clear any pending input/output buffers associated with the device.
Return	<u>On success, return the predefined Result value OK; otherwise, return one of the predefined Result values indicating failure. See 12.4.6 STI Infrastructure-Provided Result Values.</u> On error, returns one of the defined Result error constants. On success, return status code OK.
Implemented By	Device or Platform Provider
Invoked By	Infrastructure
Notes	This operation should ensure that any existing data that may be buffered within the hardware device or control software is cleared, such that subsequent read operations (for source devices) or write operations (for sink devices) only transfer new data. It is implementation-defined how existing data that has not yet been fully transferred is handled. On a sink device, the operation may wait until the data is transferred, or the data may be discarded, depending on what is more appropriate for the device and the system context. On a source device, any received but unread data should typically be discarded. The device developer or platform provider should document the behavior of this operation.

Formatted: Heading 3, Indent: Left: 0", First line: 0"

Formatted: Border: Top: (No border), Bottom: (No border), Left: (No border), Right: (No border)

12.4712.6.5 STI Device-Provided DEV_Unload Method

STI-45 The STI infrastructure shall provide the DEV_Unload()~~Definition- definition~~ as specified in ~~Table 29~~Table 37 to be implemented by an STI device.

Table 2937: DEV_Unload() Definition

Formatted: Heading 3, Indent: Left: 0", First line: 0"

Formatted: Default Paragraph Font, Font: 10.5 pt, Font color: Auto, Pattern: Clear

Declaration	interface DeviceControl :ApplicationControl { Result DEV_Unload(); };
Description	Unload a binary image or configuration file to from the device.
Return	On success, return the predefined Result value OK; otherwise, return one of the predefined Result values indicating failure. See 12.4.6 STI Infrastructure-Provided Result Values. On error, returns one of the defined Result error constants. On success, return status code OK.
Implemented By	Device or Platform Provider
Invoked By	Infrastructure
Notes	This operation clears any programming information from the device. Ideally this should be the inverse of the DEV_Load () operation. If the device does not support this operation, this may be implemented as a “no-op”.

Formatted: Border: Top: (No border), Bottom: (No border), Left: (No border), Right: (No border)

12.4812.6.6 STI Device-Provided DEV_Close Method

STI-46 The STI infrastructure shall provide the DEV_Close() ~~Definition- definition~~ as specified in ~~Table 30~~Table 38 to be implemented by an STI device.

Table 3038: DEV_Close() Definition

Declaration	interface DeviceControl :ApplicationControl { Result DEV_Close(); };
Description	Closes the device.
Return	On success, return the predefined Result value OK; otherwise, return one of the predefined Result values indicating failure. See 12.4.6 STI Infrastructure-Provided Result Values. On error, returns one of the defined Result error constants. On success, return status code OK.
Implemented By	Device or Platform Provider
Invoked By	Infrastructure
Notes	This operation should be the inverse of the DEV_Open () operation. If the open operation was a no-op, this operation should also be empty and it should return the predefined Result value OK for compatibility.

Formatted: Heading 3, Indent: Left: 0", First line: 0"

Formatted: Border: Top: (No border), Bottom: (No border), Left: (No border), Right: (No border)

12.49STI Application-Provided APP_Read Method

STI-47 The STI infrastructure shall provide the APP_Read() Definition as specified in Table 31 to be implemented, as needed, by an STI application or device.

Table 31: APP_Read() Definition

Declaration	interface Source { Result APP_Read(out Message buffer); };
--------------------	---

Formatted: Heading 3, Indent: Left: 0", First line: 0"

Formatted: Default Paragraph Font, Font: 10.5 pt, Font color: Auto, Pattern: Clear

Description	The buffer is filled with data from the component.
Parameters	► <code>buffer</code> : a storage area for data transferred from the target
Return	Status code which the caller should validate using <code>ISOK()</code> . On error, returns one of the defined <code>Result</code> error constants. On success, the return value indicates the number of units of data (records or bytes) actually obtained from the application or device, which may be less than the complete buffer size.
Implemented By	Application
Invoked By	Infrastructure
Notes	The actual storage for the buffer is allocated by the caller or infrastructure prior to invoking this function. The application should fill the buffer to the maximum extent possible and return the amount of buffer actually filled. The application developer defines the specific format and units for the buffer. In languages with direct memory access (e.g. C), it may be an arbitrary memory buffer with the units specified in bytes. In other languages, the units should reflect logical records, such as a number of characters, samples or objects. The infrastructure makes no assumptions about the format of the message data, nor the presence or expectation of a terminating entity, such as a NUL character (“\0”) as required for C-style strings. If a terminating character is required, the caller will ensure that sufficient space is available in the buffer to store the termination character. If an error is returned by an implementation, a corresponding message to indicate details of the failure should be written to the log facility for diagnostic purposes. For C/C++ implementations, the abstract <code>buffer</code> parameter is translated to two parameters, a base object pointer and size.

12.50 STI Application-Provided APP_Write Method

STI 48 – The STI infrastructure shall provide the `APP_Write()` Definition as specified in Table 32 to be implemented, as needed, by an STI application or device.

Table 32: `APP_Write()` Definition

Declaration	<pre>interface Sink { Result APP_Write(in Message buffer); };</pre>
Description	The buffer data is sent to the target component.
Parameters	► <code>buffer</code> : an abstract data set that should be transferred to the target
Return	Status code which the caller should validate using <code>ISOK()</code> . On error, returns one of the defined <code>Result</code> error constants. On success, the return value indicates the number of units of data (records or bytes) actually sent to the application or device, which may be less than the buffer size.
Implemented By	Application
Invoked By	Infrastructure

Formatted: Heading 3, Indent: Left: 0", First line: 0"

Formatted: Default Paragraph Font, Font: 10.5 pt, Font color: Auto, Pattern: Clear

Notes	<p>The actual storage for the buffer is allocated and filled by the caller or infrastructure prior to invoking this function. The application should transfer the data to the maximum extent possible and return the amount of buffer actually transferred to the device. The application developer defines the specific format and units for the buffer. In languages with direct memory access (e.g. C), it may be an arbitrary memory buffer with the units specified in bytes. In other languages, the units should reflect logical records, such as a number of characters, samples or objects.</p> <p>The infrastructure makes no assumptions about the format of the message data, nor the presence or expectation of a terminating entity, such as a NUL character ('\0') as required for C style strings. If a terminating character is required, the caller will ensure that it has been added to the buffer prior to invoking this operation.</p> <p>If an error is returned by an implementation, a corresponding message to indicate details of the failure should be written to the log facility for diagnostic purposes.</p> <p>For C/C++ implementations, the abstract <code>buffer</code> parameter is translated to two parameters, a base object pointer and size.</p>
--------------	---

12.51 STI Application-Provided APP_AddressRead Method

STI 49 The STI infrastructure shall provide the APP_AddressRead() Definition as specified in Table 33 to be implemented, as needed, by an STI application or device.

Table 33: APP_AddressRead() Definition

Declaration	<pre>interface RandomAccess { Result APP_AddressRead(in Offset offset, out Message buffer); };</pre>
Description	The buffer is filled with data from the component at the specified location
Parameters	<ul style="list-style-type: none"> ▶ <code>offset</code>: the location to read data from ▶ <code>buffer</code>: a storage area for data transferred from the target
Return	Status code which the caller should validate using <code>ISOK()</code> . On error, returns one of the defined <code>Result</code> error constants. On success, the return value indicates the number of units of data (defined by the platform developer) actually obtained from the application or device, which may be less than the complete buffer size.
Implemented By	Application
Invoked By	Infrastructure

Formatted: Heading 3, Indent: Left: 0", First line: 0"

Formatted: Default Paragraph Font, Font: 10.5 pt, Font color: Auto, Pattern: Clear

Notes	<p>The actual storage for the buffer is allocated by the caller or infrastructure prior to invoking this function. The application should fill the buffer to the maximum extent possible and return the amount of buffer actually filled.</p> <p>The application developer defines the specific format and units for the buffer. In languages with direct memory access (e.g. C), it may be an arbitrary memory buffer with the units specified in bytes. In other languages, the units should reflect logical records, such as a number of characters, samples or objects.</p> <p>The infrastructure makes no assumptions about the format of the message data, nor the presence or expectation of a terminating entity, such as a NUL character ('\0') as required for C style strings. If a terminating character is required, the caller will ensure that sufficient space is available in the buffer to store the termination character.</p> <p>If an error is returned by an implementation, a corresponding message to indicate details of the failure should be written to the log facility for diagnostic purposes.</p> <p>For C/C++ implementations, the abstract <code>buffer</code> parameter is translated to two parameters, a base object pointer and size.</p>
--------------	--

12.52 STI Application-Provided APP_AddressWrite Method

STI-50 The STI infrastructure shall provide the APP_AddressWrite() Definition as specified in Table 34 to be implemented, as needed, by an STI application or device.

Formatted: Heading 3, Indent: Left: 0", First line: 0"

Table 34: APP_AddressWrite() Definition

Declaration	<pre>interface RandomAccess { Result APP_AddressWrite(in Offset offset, in Message buffer); };</pre>
Description	The buffer data is written to the target component at the specified location
Parameters	<ul style="list-style-type: none"> ▶ <code>offset</code>: the location to write the data ▶ <code>buffer</code>: an abstract data set that should be transferred to the target
Return	Status code which the caller should validate using <code>ISOK()</code> . On error, returns one of the defined <code>Result</code> error constants values. On success, the return value indicates the number of units of data (records or bytes) actually sent to the application or device, which may be less than the buffer size.
Implemented By	Application
Invoked By	Infrastructure

Formatted: Default Paragraph Font, Font: 10.5 pt, Font color: Auto, Pattern: Clear

Notes	<p>The actual storage for the buffer is allocated and filled by the caller or infrastructure prior to invoking this function. The application should transfer the data to the maximum extent possible and return the amount of buffer actually transferred to the device. The application developer defines the specific format and units for the buffer. In languages with direct memory access (e.g. C), it may be an arbitrary memory buffer with the units specified in bytes. In other languages, the units should reflect logical records, such as a number of characters, samples or objects.</p> <p>The infrastructure makes no assumptions about the format of the message data, nor the presence or expectation of a terminating entity, such as a NUL character ('\0') as required for C style strings. If a terminating character is required, the caller will ensure that it has been added to the buffer prior to invoking this operation.</p> <p>If an error is returned by an implementation, a corresponding message to indicate details of the failure should be written to the log facility for diagnostic purposes.</p> <p>For C/C++ implementations, the abstract <code>buffer</code> parameter is translated to two parameters, a base object pointer and size.</p>
--------------	---

Formatted: Normal, Indent: Left: 0", First line: 0"

12.7 STI Infrastructure-Provided Methods

Formatted: Font: 14 pt

“Provide a definition” implies supplying a consistent interface, which may be used or inherited by other methods. The implementation of such an interface may be supplied by others. For functions, an abstract method or class, a virtual method, or prototype is usually supplied.

The following items in section 12.7 are expected to appear in module STI.

Commented [HLM(L40): [JIRA issue STI_35: Add extra introductory remarks to 12.5, 12.6, and 12.7.](#)
[JIRA issue STI_37: Clarify definition vs implementation](#)

12.7.1 STI Infrastructure-Provided IsOK Method

STI-51 The STI infrastructure shall provide the `IsOK()` definition and implementation as specified in Table 35 Table 39.

Formatted: Font: 10.5 pt

Formatted: Heading 3, Indent: Left: 0", First line: 0"

Table 35: `IsOK()` Definition

Declaration	boolean <code>IsOK()</code> in <code>Result</code> status);
Description	Determine if a <code>Result</code> value represents a successful response.
Parameters	► <code>status</code> : A return value from a previous call
Return	If the <code>Result status code status value</code> represents a successful result, evaluates as TRUE. If the <code>Result status code status value</code> represents a failure, evaluates as FALSE.
Implemented By	Infrastructure
Invoked By	Application, Service, or Device
Notes	Converts a <code>Result status code value</code> from any previous API call into a boolean value that can be used in conjunction with the programming language conditional statements. For efficiency reasons, this may be implemented as a macro or inline function in languages which support this concept.

Formatted: Border: Top: (No border), Bottom: (No border), Left: (No border), Right: (No border)

Formatted: Default Paragraph Font, Font: 10.5 pt, Font color: Auto, Pattern: Clear

12.54 12.7.2 STI Infrastructure-Provided ValidateHandleID Method

STI-52 The STI infrastructure shall provide the ValidateHandleID() ~~Definition()~~ definition and implementation as specified in ~~Table 36~~ Table 40.

Table 3640: ValidateHandleID() Definition

Declaration	Result ValidateHandleID(in HandleID id);
Description	Determine if a HandleID value is valid.
Parameters	► id: A return value from a previous call
Return	If the handle ID value is valid, returns the <u>return the status-predefined Result</u> value OK. If the handle ID is not valid, returns one of the defined error constants. Otherwise, return one of the predefined Result values indicating failure. See 12.4.6 STI Infrastructure-Provided Result Values.
Implemented-By	Infrastructure
Invoked-By	Application, Service, or Device
Notes	This is used to check the result of any function returning a HandleID value. The result of this function should be passed to IsOK() for use in any conditional test.

Formatted: Heading 3, Indent: Left: 0", First line: 0"

Formatted: Border: Top: (No border), Bottom: (No border), Left: (No border), Right: (No border)

Formatted Table

12.55 12.7.3 STI Infrastructure-Provided ValidateSize Method

STI-53 The STI infrastructure shall provide the ValidateSize() ~~Definition()~~ definition and implementation as specified in ~~Table 37~~ Table 41.

Table 3741: ValidateSize() Definition

Declaration	Result ValidateSize(in FileSize size);
Description	Determine if a FileSize value is valid.
Parameters	► size: A return value from a previous call
Return	If the size value is valid, returns the <u>return the predefined Resultstatus</u> value OK. Otherwise, return one of the predefined Result values indicating failure. See 12.4.6 STI Infrastructure-Provided Result Values. If the size is not valid, returns one of the defined error constants.
Implemented-By	Infrastructure
Invoked-By	Application, Service, or Device
Notes	This is used to check the result of any function returning a FileSize value. The result of this function should be passed to IsOK() for use in any conditional test.

Formatted: Heading 3, Indent: Left: 0", First line: 0"

Formatted: Border: Top: (No border), Bottom: (No border), Left: (No border), Right: (No border)

Formatted: Default Paragraph Font, Font: 10.5 pt, Font color: Auto, Pattern: Clear

12.5612.7.4 STI Infrastructure-Provided InstantiateApp Method

STI-54 The STI infrastructure shall provide the InstantiateApp() ~~Definition()~~ definition and implementation as specified in ~~Table 38~~ Table 42.

Table 3842: InstantiateApp() Definition

Declaration	HandleID InstantiateApp(in HandleID fromID, in string handleName, in string configuration);
Description	Instantiate an application or service.
Parameters	<ul style="list-style-type: none"> ▶ fromID: The handle ID of the current component making the request. ▶ handleName: The name of the new component to be instantiated. ▶ configuration: Configuration data to be associated with the new instance. If NULL or undefined, the STI Infrastructure should use defaults if appropriate/possible.
Return	On success, returns <u>return</u> a Handle ID value identifying the newly created instance. On error otherwise, an invalid handle ID value is returned <u>return the predefined HANDLEID_INVALID.</u> The returned handle value should always be validated by the caller using the ValidateHandleID() API call to determine success or failure.
Implemented By	Infrastructure
Invoked By	Application, Service, or Device
Notes	<p><u>The caller should validate the return HandleID value using the ValidateHandleID() API call to determine success or failure.</u></p> <p>The handle name specified for the application, service, or device is to be unique within the scope of the current STI environment.</p> <p>The STI Infrastructure may also impose additional operations to be performed during instantiation, such as the loading of dynamic link libraries or shared objects, as documented by the platform provider. It is up to the STI Infrastructure to determine whether any additional resources are to be loaded to accomplish the instantiation.</p> <p>The configuration parameter will be a free-form string, defined by the platform provider, and intended as a generic means to pass additional instructions to the infrastructure as part of the instantiation process. This string may directly contain a set of encoded configuration data (e.g. XML), or it may refer to a filename on the system storage device containing additional information about the instance.</p>

Formatted: Heading 3, Indent: Left: 0", First line: 0"

Formatted: Border: Top: (No border), Bottom: (No border), Left: (No border), Right: (No border)

Formatted Table

12.5712.7.5 STI Infrastructure-Provided GetErrorQueue Method

STI-55 The STI infrastructure shall provide the GetErrorQueue() ~~Definition()~~ definition and implementation as specified in ~~Table 39~~ Table 43.

Table 431539: GetErrorQueue() Definition

Declaration	HandleID GetErrorQueue(in Result status);
--------------------	---

Formatted: Heading 3, Indent: Left: 0", First line: 0"

Formatted: Border: Top: (No border), Bottom: (No border), Left: (No border), Right: (No border)

Formatted: Default Paragraph Font, Font: 10.5 pt, Font color: Auto, Pattern: Clear

Description	Obtain the error queue associated with the given status value.
Parameters	▶ status: A <u>Result</u> error <u>status-code-value</u> from a previous call
Return	Returns <u>Return</u> a handle ID value identifying the queue to which any associated log message should be written.
Implemented By	Infrastructure
Invoked By	Application, Service, or Device
Notes	This call is intended for use in conjunction with the Log () function for preserving error-related context information. The platform may direct different types of errors to different log queues to aid with diagnostics. For any given error response, this locates the proper queue for logging of any related information. In general, this should only be used for error <u>status-codesResult values</u> (i.e. those for which IsOK () returns FALSE). However, in all cases, the return value from this function will be passable directly to the Log () routine, without further validation, for any <u>status-codeResult value</u> .

12.5812.7.6 STI Infrastructure-Provided GetHandleName Method

STI-56 The STI infrastructure shall provide the GetHandleName() Definition-() definition and implementation as specified in Table 40Table 44.

Table 4044: GetHandleName() Definition

Declaration	<u>string-Result</u> GetHandleName(in HandleID fromID, in HandleID toID, <u>out string handleName</u>);
Description	Obtain the handle name associated with the given handle ID <u>(toID)</u> .
Parameters	▶ fromID: The handle ID of the current component making the request. ▶ toID: The handle ID of the component for which the name is to be obtained ▶ <u>handleName</u> : A string representing the handle name of the referenced <u>(toID)</u> application
Return	<u>On success, returns a string representing the handle name. On error, returns an undefined or invalid value. On success, return the predefined Result value; otherwise, return one of the predefined Result values indicating failure. See 12.4.6 STI Infrastructure-Provided Result Values.</u>
Implemented By	Infrastructure
Invoked By	Application, Service, or Device
Notes	<u>The caller is responsible for preallocating the size of handleName to [MAX_HANDLE_NAME_SIZE+1]. If the infrastructure cannot obtain the correct handle name, the infrastructure will return a value that does not alias a valid handle name, such as NULL in C/C++ or the corresponding undefined value representation in other languages.</u>

Formatted: Heading 3, Indent: Left: 0", First line: 0"

Formatted: Border: Top: (No border), Bottom: (No border), Left: (No border), Right: (No border)

Formatted: Don't keep with next

Formatted: Default Paragraph Font, Font: 10.5 pt, Font color: Auto, Pattern: Clear

12.59 12.7.7 STI Infrastructure-Provided HandleRequest Method

STI-57 The STI infrastructure shall provide the HandleRequest() ~~Definition ()~~ definition and implementation as specified in ~~Table 44~~Table 45.

Table 445: HandleRequest() Definition

Declaration	HandleID HandleRequest(in HandleID fromID, in string toName);
Description	Obtain the handle ID associated with the given handle name.
Parameters	<ul style="list-style-type: none"> ▶ fromID: The handle ID of the current component making the request. ▶ toName: The handle name of the component for which the ID should be obtained
Return	On success, returns return a Handle ID value identifying the component. On error, an invalid handle ID value is returned return the predefined HANDLEID_INVALID. The returned value should always be validated by the caller using the ValidateHandleID() API call to determine success or failure.
Implemented By	Infrastructure
Invoked By	Application, Service, or Device
Notes	The caller should always validate the returned value using the ValidateHandleID() API call to determine success or failure.

Formatted: Heading 3, Indent: Left: 0", First line: 0"

Formatted: Border: Top: (No border), Bottom: (No border), Left: (No border), Right: (No border)

12.60 12.7.8 STI Infrastructure-Provided AbortApp Method

STI-58 The STI infrastructure shall provide the AbortApp() ~~Definition ()~~ definition and implementation as specified in ~~Table 42~~Table 46.

Table 4246: AbortApp() Definition

Declaration	Result AbortApp(in HandleID fromID, in HandleID toID);
Description	Abort an application or service.
Parameters	<ul style="list-style-type: none"> ▶ fromID: The handle ID of the current component making the request. ▶ toID: The handle ID of the target component that should respond to the request
Return	On success, return the predefined Result value OK; otherwise, return one of the predefined Result values indicating failure. See 12.4.6 STI Infrastructure-Provided Result Values, Status code which the caller should validate using ISOK(). On error, returns one of the defined Result error constants. On success, returns OK.
Implemented By	Infrastructure
Invoked By	Application, Service, or Device
Notes	The target component will be removed from the environment, and any system resources associated with it should be released.

Formatted: Heading 3, Indent: Left: 0", First line: 0"

Formatted: Border: Top: (No border), Bottom: (No border), Left: (No border), Right: (No border)

Formatted Table

Formatted: Default Paragraph Font, Font: 10.5 pt, Font color: Auto, Pattern: Clear

12.6412.7.9 STI Infrastructure-Provided Initialize Method

STI-59 The STI infrastructure shall provide the Initialize()~~Definition()~~ definition and implementation as specified in ~~Table 43~~Table 47.

Table 4347: Initialize() Definition

Declaration	Result Initialize(in HandleID fromID, in HandleID toID);
Description	Initialize the target component.
Parameters	▶ fromID: The handle ID of the current component making the request ▶ toID: The handle ID of the component that should respond to the request
Return	<u>On success, return the predefined Result value OK; otherwise, return one of the predefined Result values indicating failure. See 12.4.6 STI Infrastructure-Provided Result Values.</u> On error, returns one of the defined error constants. On success, returns OK.
Implemented By	Infrastructure
Invoked By	Application, Service, or Device
Notes	This sets the component to a known initial state. The specific definition of this state is application-defined. This triggers the APP_Initialize() operation on the target interface.

Formatted: Heading 3, Indent: Left: 0", First line: 0"

Formatted: Border: Top: (No border), Bottom: (No border), Left: (No border), Right: (No border)

12.6212.7.10 STI Infrastructure-Provided ReleaseObject Method

STI-60 The STI infrastructure shall provide the ReleaseObject()~~Definition()~~ definition and implementation as specified in ~~Table 44~~Table 48.

Table 4448: ReleaseObject() Definition

Declaration	Result ReleaseObject(in HandleID fromID, in HandleID toID);
Description	Releases any system resources held by the application or component.
Parameters	▶ fromID: The handle ID of the current component making the request ▶ toID: The handle ID of the component that should respond to the request
Return	<u>On success, return the predefined Result value OK; otherwise, return one of the predefined Result values indicating failure. See 12.4.6 STI Infrastructure-Provided Result Values.</u> On error, returns one of the defined error constants. On success, returns OK.
Implemented By	Infrastructure
Invoked By	Application, Service, or Device

Formatted: Heading 3, Indent: Left: 0", First line: 0"

Formatted: Border: Top: (No border), Bottom: (No border), Left: (No border), Right: (No border)

Formatted: Default Paragraph Font, Font: 10.5 pt, Font color: Auto, Pattern: Clear

Notes	This triggers the APP_ReleaseObject () operation on the target interface.
-------	---

12.63 12.7.11 STI Infrastructure-Provided Configure Method

STI-61 The STI infrastructure shall provide the Configure() ~~Definition ()~~ definition and implementation as specified in ~~Table 45~~ Table 49.

Table 4549: Configure() Definition

Declaration	Result Configure(in HandleID fromID, in HandleID toID, in PropertyName propName, in PropertyValue propValue);
Description	Configures or sets a single property in the target component.
Parameters	<ul style="list-style-type: none"> ▶ fromID: The handle ID of the current component making the request ▶ toID: The handle ID of the component that should respond to the request ▶ propName: The name or identifier of the property to set ▶ propValue: A buffer containing the value to set the property to
Return	On success, return the predefined Result value OK; otherwise, return one of the predefined Result values indicating failure. See 12.4.6 STI Infrastructure-Provided Result Values. On error, returns one of the defined error constants. On success, returns OK.
Implemented By	Infrastructure
Invoked By	Application, Service, or Device
Notes	The caller manages the memory associated with the value buffer. This triggers the APP_Configure () operation in the target interface.

Formatted: Heading 3, Indent: Left: 0", First line: 0"

Formatted: Border: Top: (No border), Bottom: (No border), Left: (No border), Right: (No border)

12.64 12.7.12 STI Infrastructure-Provided Query Method

STI-62 The STI infrastructure shall provide the Query() ~~Definition ()~~ definition and implementation as specified in ~~Table 46~~ Table 50.

Table 4650: Query() Definition

Declaration	Result Query(in HandleID fromID, in HandleID toID, in PropertyName propName, out PropertyValue propValue);
Description	Obtains or gets a single property from the target component.

Formatted: Heading 3, Indent: Left: 0", First line: 0"

Formatted: Border: Top: (No border), Bottom: (No border), Left: (No border), Right: (No border)

Formatted: Default Paragraph Font, Font: 10.5 pt, Font color: Auto, Pattern: Clear

Parameters	<ul style="list-style-type: none"> ▶ fromID: The handle ID of the current component making the request ▶ toID: The handle ID of the component that should respond to the request ▶ propName: The name or identifier of the property to get ▶ propValue: A buffer into which the current value should be stored
Return	On success, return the predefined Result value OK; otherwise, return one of the predefined Result values indicating failure. See 12.4.6 STI Infrastructure-Provided Result Values. On error, returns one of the defined error constants. On success, returns OK.
Implemented By	Infrastructure
Invoked By	Application, Service, or Device
Notes	The caller manages the memory associated with the value buffer. This triggers the APP_Query () operation in the target interface.

12.65 12.7.13 STI Infrastructure-Provided RunTest Method

STI-63 The STI infrastructure shall provide the RunTest() ~~Definition ()~~ definition and implementation as specified in ~~Table 47~~ Table 51.

Table 47 ~~51~~: RunTest() Definition

Declaration	Result RunTest(in HandleID fromID, in HandleID toID, in TestID testID);
Description	Obtain the handle ID associated with the given handle name.
Parameters	<ul style="list-style-type: none"> ▶ fromID: The handle ID of the current component making the request ▶ toID: The handle ID of the component that should respond to the request ▶ testID: The ID of the test to be performed
Return	On success, return the predefined Result value OK; otherwise, return one of the predefined Result values indicating failure. See 12.4.6 STI Infrastructure-Provided Result Values. On error, returns one of the defined error constants. On success, returns OK.
Implemented By	Infrastructure
Invoked By	Application, Service, or Device
Notes	The specific values and meaning of the testID parameter are application specific. This triggers the APP_RunTest () operation in the target interface.

Formatted: Heading 3, Indent: Left: 0", First line: 0"

Formatted: Border: Top: (No border), Bottom: (No border), Left: (No border), Right: (No border)

12.66 12.7.14 STI Infrastructure-Provided Start Method

STI-64 The STI infrastructure shall provide the Start() ~~Definition ()~~ definition and implementation as specified in ~~Table 48~~ Table 52.

Table 48 ~~52~~: Start() Definition

Formatted: Heading 3, Indent: Left: 0", First line: 0"

Formatted: Default Paragraph Font, Font: 10.5 pt, Font color: Auto, Pattern: Clear

Declaration	Result Start(in HandleID fromID, in HandleID toID);
Description	Begin normal application or device processing.
Parameters	<ul style="list-style-type: none"> ▶ fromID: The handle ID of the current component making the request ▶ toID: The handle ID of the component that should respond to the request
Return	<u>On success, return the predefined Result value OK; otherwise, return one of the predefined Result values indicating failure. See 12.4.6 STI Infrastructure-Provided Result Values.</u> On error, returns one of the defined error constants. On success, returns OK.
Implemented By	Infrastructure
Invoked By	Application, Service, or Device
Notes	This triggers the APP_Start () operation in the target interface.

Formatted: Border: Top: (No border), Bottom: (No border), Left: (No border), Right: (No border)

12.6712.7.15 STI Infrastructure-Provided Stop Method

STI-65 The STI infrastructure shall provide the Stop()~~Definition ()~~ definition and implementation as specified in ~~Table 49~~Table 53.

Table 4953: Stop() Definition

Declaration	Result Stop(in HandleID fromID, in HandleID toID);
Description	End normal application or device processing.
Parameters	<ul style="list-style-type: none"> ▶ fromID: The handle ID of the current component making the request ▶ toID: The handle ID of the component that should respond to the request
Return	<u>On success, return the predefined Result value OK; otherwise, return one of the predefined Result values indicating failure. See 12.4.6 STI Infrastructure-Provided Result Values.</u> On error, returns one of the defined error constants. On success, returns OK.
Implemented By	Infrastructure
Invoked By	Application, Service, or Device
Notes	This triggers the APP_Stop () operation in the target interface.

Formatted: Heading 3, Indent: Left: 0", First line: 0"

Formatted: Border: Top: (No border), Bottom: (No border), Left: (No border), Right: (No border)

Formatted Table

12.6812.7.16 STI Infrastructure-Provided DeviceOpen Method

STI-66 The STI infrastructure shall provide the DeviceOpen()~~Definition ()~~ definition and implementation as specified in ~~Table 50~~Table 54.

Table 5054: DeviceOpen() Definition

Formatted: Heading 3, Indent: Left: 0", First line: 0"

Formatted: Default Paragraph Font, Font: 10.5 pt, Font color: Auto, Pattern: Clear

Declaration	Result DeviceOpen(in HandleID fromID, in HandleID toID);
Description	Open the device.
Parameters	<ul style="list-style-type: none"> ▶ fromID: The handle ID of the current component making the request ▶ toID: The handle ID of the component that should respond to the request
Return	<u>On success, return the predefined Result value OK; otherwise, return one of the predefined Result values indicating failure. See 12.4.6 STI Infrastructure-Provided Result Values.</u> On error, returns one of the defined error constants. On success, returns OK.
Implemented By	Infrastructure
Invoked By	Application, Service, or Device
Notes	This triggers the DEV_Open () operation in the target interface. This will be the first call issued before invoking any other device control operations.

Formatted: Border: Top: (No border), Bottom: (No border), Left: (No border), Right: (No border)

12.69 12.7.17 STI Infrastructure-Provided DeviceLoad Method

STI-67 The STI infrastructure shall provide the DeviceLoad(~~Definition()~~definition and implementation as specified in ~~Table 54~~Table 55.

Table ~~54~~55: DeviceLoad() Definition

Declaration	Result DeviceLoad(in HandleID fromID, in HandleID toID, in string fileName);
Description	Load an application, hardware design, or configuration file into the device.
Parameters	<ul style="list-style-type: none"> ▶ fromID: The handle ID of the current component making the request ▶ toID: The handle ID of the component that should respond to the request ▶ fileName: The name of the file to load
Return	<u>On success, return the predefined Result value OK; otherwise, return one of the predefined Result values indicating failure. See 12.4.6 STI Infrastructure-Provided Result Values.</u> On error, returns one of the defined error constants. On success, returns OK.
Implemented By	Infrastructure
Invoked By	Application, Service, or Device
Notes	This triggers the DEV_Load () operation in the target interface.

Formatted: Heading 3, Indent: Left: 0", First line: 0"

Formatted: Border: Top: (No border), Bottom: (No border), Left: (No border), Right: (No border)

Formatted Table

Formatted: Default Paragraph Font, Font: 10.5 pt, Font color: Auto, Pattern: Clear

12.7012.7.18 STI Infrastructure-Provided DeviceReset Method

STI-68 The STI infrastructure shall provide the DeviceReset(~~Definition()~~, ~~definition and implementation~~ as specified in ~~Table 52~~Table 56.

Table 5256: DeviceReset() Definition

Declaration	Result DeviceReset(in HandleID fromID, in HandleID toID);
Description	Resets the device into a known state.
Parameters	<ul style="list-style-type: none"> ▶ fromID: The handle ID of the current component making the request ▶ toID: The handle ID of the component that should respond to the request
Return	On success, return the predefined Result value OK; otherwise, return one of the predefined Result values indicating failure. See 12.4.6 STI Infrastructure-Provided Result Values. On error, returns one of the defined error constants. On success, returns OK.
Implemented By	Infrastructure
Invoked By	Application, Service, or Device
Notes	The specific state after reset is device-defined. This triggers the DEV_Reset () operation in the target interface.

Formatted: Heading 3, Indent: Left: 0", First line: 0"

Formatted: Border: Top: (No border), Bottom: (No border), Left: (No border), Right: (No border)

12.7412.7.19 STI Infrastructure-Provided DeviceFlush Method

STI-69 The STI infrastructure shall provide the DeviceFlush(~~Definition()~~, ~~definition and implementation~~ as specified in ~~Table 53~~Table 57.

Table 5357: DeviceFlush() Definition

Declaration	Result DeviceFlush(in HandleID fromID, in HandleID toID);
Description	Clears any pending input/output data buffers in the device.
Parameters	<ul style="list-style-type: none"> ▶ fromID: The handle ID of the current component making the request ▶ toID: The handle ID of the component that should respond to the request
Return	On success, return the predefined Result value OK; otherwise, return one of the predefined Result values indicating failure. See 12.4.6 STI Infrastructure-Provided Result Values. On error, returns one of the defined error constants. On success, returns OK.
Implemented By	Infrastructure
Invoked By	Application, Service, or Device
Notes	This triggers the DEV_Flush () operation in the target interface.

Formatted: Heading 3, Indent: Left: 0", First line: 0"

Formatted: Border: Top: (No border), Bottom: (No border), Left: (No border), Right: (No border)

Formatted: Default Paragraph Font, Font: 10.5 pt, Font color: Auto, Pattern: Clear

12.7.20 STI Infrastructure-Provided DeviceUnload Method

STI-70 The STI infrastructure shall provide the DeviceUnload() ~~Definition()~~ definition and implementation as specified in ~~Table 54~~ Table 58.

Table 5458: DeviceUnload() Definition

Declaration	Result DeviceUnload(in HandleID fromID, in HandleID toID);
Description	Unload any previously loaded application, hardware design image, or configuration file.
Parameters	<ul style="list-style-type: none"> ▶ fromID: The handle ID of the current component making the request ▶ toID: The handle ID of the component that should respond to the request
Return	On success, return the predefined Result value OK; otherwise, return one of the predefined Result values indicating failure. See 12.4.6 STI Infrastructure-Provided Result Values. <u>On error, returns one of the defined error constants. On success, returns OK.</u>
Implemented By	Infrastructure
Invoked By	Application, Service, or Device
Notes	This triggers the DEV_Unload() operation in the target interface.

Formatted: Heading 3, Indent: Left: 0", First line: 0"

Formatted: Border: Top: (No border), Bottom: (No border), Left: (No border), Right: (No border)

12.7.21 STI Infrastructure-Provided DeviceClose Method

STI-71 The STI infrastructure shall provide the DeviceClose() ~~Definition()~~ definition and implementation as specified in ~~Table 55~~ Table 59.

Table 5559: DeviceClose() Definition

Declaration	Result DeviceClose(in HandleID fromID, in HandleID toID);
Description	Closes the device.
Parameters	<ul style="list-style-type: none"> ▶ fromID: The handle ID of the current component making the request ▶ toID: The handle ID of the component that should respond to the request
Return	On success, return the predefined Result value OK; otherwise, return one of the predefined Result values indicating failure. See 12.4.6 STI Infrastructure-Provided Result Values. <u>On error, returns one of the defined error constants. On success, returns OK.</u>
Implemented By	Infrastructure
Invoked By	Application, Service, or Device
Notes	This triggers the DEV_Close() operation in the target interface. The device will not be used by the application after this call unless opened again.

Formatted: Heading 3, Indent: Left: 0", First line: 0"

Formatted: Border: Top: (No border), Bottom: (No border), Left: (No border), Right: (No border)

Formatted: Default Paragraph Font, Font: 10.5 pt, Font color: Auto, Pattern: Clear

12.74 12.7.22 STI Infrastructure-Provided Read Method

STI-72 The STI infrastructure shall provide the Read() ~~Definition()~~ definition and implementation as specified in ~~Table 56~~ Table 60.

Table 5660: Read() Definition

Declaration	Result Read(in HandleID fromID, in HandleID toID, out Message buffer);
Description	Read or “pull” arbitrary data from another application or device.
Parameters	<ul style="list-style-type: none"> ▶ fromID: The handle ID of the current component making the request ▶ toID: The handle ID of the component that should respond to the request ▶ buffer: A buffer to hold the transferred data
Return	On error, returns one of the defined error constants. On success, returns return a Result status value indicating the actual number of records or bytes of data that was transferred into the supplied buffer. Otherwise, return one of the predefined Result values indicating failure. See 12.4.6 STI Infrastructure-Provided Result Values. The caller will check the return status using ISOK().
Implemented By	Infrastructure
Invoked By	Application, Service, or Device
Notes	<p>The storage for the buffer will be managed by the caller. The target application defines the specific binary format for the data.</p> <p>In languages with direct memory access (e.g. C/C++), the buffer is an arbitrary memory location with the units specified in bytes. In other languages, the units should reflect logical records, such as a number of characters, samples or objects.</p> <p>The infrastructure makes no assumptions about the format of the message data, nor the presence or expectation of a terminating entity, such as a NUL character ('\0') as required for C-style strings. If a terminating character is required, the caller will ensure that sufficient space is available in the buffer to store the termination character.</p>

Formatted: Heading 3, Indent: Left: 0", First line: 0"

Formatted: Border: Top: (No border), Bottom: (No border), Left: (No border), Right: (No border)

12.75 12.7.23 STI Infrastructure-Provided Write Method

STI-73 The STI infrastructure shall provide the Write() ~~Definition()~~ definition and implementation as specified in ~~Table 57~~ Table 61.

Table 5761: Write() Definition

Declaration	Result Write(in HandleID fromID, in HandleID toID, in Message buffer);
Description	Write or “push” arbitrary data to another application or device.

Formatted: Heading 3, Indent: Left: 0", First line: 0"

Formatted: Border: Top: (No border), Bottom: (No border), Left: (No border), Right: (No border)

Formatted: Default Paragraph Font, Font: 10.5 pt, Font color: Auto, Pattern: Clear

Parameters	<ul style="list-style-type: none"> ▶ <code>fromID</code>: The handle ID of the current component making the request ▶ <code>toID</code>: The handle ID of the component that should respond to the request ▶ <code>buffer</code>: A buffer containing the data to be transferred
Return	<p>On error, returns one of the defined error constants. On success, returns return a status value indicating the actual number of records or bytes of data that was transferred from the supplied buffer. Otherwise, return one of the predefined Result values indicating failure. See 12.4.6 STI Infrastructure-Provided Result Values. The caller will check the return status using <code>ISOK()</code>.</p>
Implemented-By	Infrastructure
Invoked-By	Application, Service, or Device
Notes	<p>The storage for the buffer will be managed by the caller. The target application defines the specific binary format for the data.</p> <p>In languages with direct memory access (e.g. C/C++), the buffer is an arbitrary memory location with the units specified in bytes. In other languages, the units should reflect logical records, such as a number of characters, samples<u>samples</u>, or objects.</p> <p>The infrastructure makes no assumptions about the format of the message data, nor the presence or expectation of a terminating entity, such as a NUL character ('\0') as required for C-style strings. If a terminating character is required, the caller will ensure that sufficient space is available in the buffer to store the termination character.</p>

Formatted Table

12.7612.7.24 STI Infrastructure-Provided AddressRead Method

STI-74 The STI infrastructure shall provide the `AddressRead()` ~~Definition()~~ definition and implementation as specified in ~~Table 58~~Table 62.

Formatted: Heading 3, Indent: Left: 0", First line: 0"

Table ~~6258~~: `AddressRead()` Definition

Declaration	<pre>Result AddressRead(in HandleID fromID, in HandleID toID, in Offset offset, out Message buffer);</pre>
Description	Read data from a specific offset or address within a device or file.
Parameters	<ul style="list-style-type: none"> ▶ <code>fromID</code>: The handle ID of the current component making the request ▶ <code>toID</code>: The handle ID of the component that should respond to the request ▶ <code>offset</code>: The location to read data from ▶ <code>buffer</code>: A buffer to hold the transferred data
Return	<p>On error, returns one of the defined error constants. On success, returns return a <u>Result</u> status value indicating the actual number of records or bytes of data that was transferred into the supplied buffer. Otherwise, return one of the predefined Result values indicating failure. See 12.4.6 STI Infrastructure-Provided Result Values. The caller will check the return status using <code>ISOK()</code>.</p>
Implemented-By	Infrastructure
Invoked-By	Application, Service, or Device

Formatted: Border: Top: (No border), Bottom: (No border), Left: (No border), Right: (No border)

Formatted: Default Paragraph Font, Font: 10.5 pt, Font color: Auto, Pattern: Clear

Notes	<p>The storage for the buffer will be managed by the caller. The target application defines the specific binary format for the data.</p> <p>In languages with direct memory access (e.g. C/C++), the buffer is an arbitrary memory location with the units specified in bytes. In other languages, the units should reflect logical records, such as a number of characters, samples<u>samples</u>, or objects.</p> <p>The infrastructure makes no assumptions about the format of the message data, nor the presence or expectation of a terminating entity, such as a NUL character ('\0') as required for C-style strings. If a terminating character is required, the caller will ensure that sufficient space is available in the buffer to store the termination character.</p>
--------------	--

12.7.25 STI Infrastructure-Provided AddressWrite Method

STI-75 The STI infrastructure shall provide the AddressWrite() ~~Definition()~~ definition and implementation as specified in ~~Table 59~~Table 63.

Table 5963: AddressWrite() Definition

Declaration	<pre>Result AddressWrite(in HandleID fromID, in HandleID toID, in Offset offset, in Message buffer);</pre>
Description	Write data to a specific offset or address within a device or file.
Parameters	<ul style="list-style-type: none"> ▶ fromID: The handle ID of the current component making the request ▶ toID: The handle ID of the component that should respond to the request ▶ offset: The location to write data to ▶ buffer: A buffer containing the data to be transferred
Return	<p>On error, returns one of the defined error constants. On success, <u>returns return</u> a status value indicating the actual number of records or bytes of data that was transferred from the supplied buffer. <u>Otherwise, return one of the predefined Result values indicating failure.</u> See 12.4.6 STI Infrastructure-Provided Result Values.</p> <p>The caller will check the return status using ISOK().</p>
Implemented-By	Infrastructure
Invoked-By	Application, Service, or Device
Notes	<p>The storage for the buffer will be managed by the caller. The target application defines the specific binary format for the data.</p> <p>In languages with direct memory access (e.g. C/C++), the buffer is an arbitrary memory location with the units specified in bytes. In other languages, the units should reflect logical records, such as a number of characters, samples<u>samples</u>, or objects.</p> <p>The infrastructure makes no assumptions about the format of the message data, nor the presence or expectation of a terminating entity, such as a NUL character ('\0') as required for C-style strings. If a terminating character is required, the caller will ensure that sufficient space is available in the buffer to store the termination character.</p>

Formatted: Heading 3, Indent: Left: 0", First line: 0"

Formatted: Border: Top: (No border), Bottom: (No border), Left: (No border), Right: (No border)

Commented [HLM(L41): [JIRA issue STI_7: Calling sequence is inconsistent](#)]

Formatted: Default Paragraph Font, Font: 10.5 pt, Font color: Auto, Pattern: Clear

12.78 12.7.26 STI Infrastructure-Provided Log Method

STI-76 The STI infrastructure shall provide the Log() ~~Definition()~~ definition and implementation as specified in ~~Table 60~~ Table 64.

Table 6064: Log() Definition

Declaration	Result Log(in HandleID fromID, in HandleID toID, in string-Message logMsgbuffer);
Description	Sends an information message to the specified log facility.
Parameters	<ul style="list-style-type: none"> ▶ fromID: The handle ID of the current component making the request ▶ toID: The handle ID of the log queue to which the message should be sent ▶ logMsgbuffer: A message to send to the log facility
Return	<u>On success, return the predefined Result value OK; otherwise, return one of the predefined Result values indicating failure. See 12.4.6 STI Infrastructure-Provided Result Values. On error, returns one of the defined error constants. On success, returns OK.</u>
Implemented By	Infrastructure
Invoked By	Application, Service, or Device
Notes	When logging context information related to errors, the GetErrorQueue() function may be used to determine the proper value to use for the toID parameter. In other cases, the predefined error queue <u>constants values</u> may be used, as listed in Table 8, HandleID <u>Constants Values</u> . Behavior is not specified if the toID parameter does not refer to a component capable of accepting log messages (i.e. one of the defined log facilities).

Formatted: Heading 3, Indent: Left: 0", First line: 0"

Formatted: Border: Top: (No border), Bottom: (No border), Left: (No border), Right: (No border)

Commented [HLM(L42): JIRA issue STI 39: Inconsistency in signature between Log and Write/APP Write

Formatted Table

12.79 12.7.27 STI Infrastructure-Provided FileOpen Method

STI-77 The STI infrastructure shall provide the FileOpen() ~~Definition()~~ definition and implementation as specified in ~~Table 64~~ Table 65.

Table 6465: FileOpen() Definition

Declaration	HandleID FileOpen(in HandleID fromID, in string fileName, in Access fileAccess, in boolean fileTypeText);
Description	Opens a file within the infrastructure file system.

Formatted: Heading 3, Indent: Left: 0", First line: 0"

Formatted: Border: Top: (No border), Bottom: (No border), Left: (No border), Right: (No border)

Commented [HLM(L43): JIRA issue STI 21: Add file type parameter to the FileOpen method. (Done in FTF1.)

Formatted: Default Paragraph Font, Font: 10.5 pt, Font color: Auto, Pattern: Clear

Parameters	<ul style="list-style-type: none"> ▶ <code>fromID</code>: The handle ID of the current component making the request ▶ <code>fileName</code>: The name of the file to be opened ▶ <code>fileAccess</code>: Whether the file is to be opened for reading, writing, appending, or both (reading and writing). ▶ <code>fileTypeText</code>: indicator whether the file is text or binary; use true for text and false for binary.
Return	On success, returns <u>return</u> a Handle ID value identifying the open file. On error <u>Otherwise, return the predefined an invalid handle ID value is returned</u> <code>HANDLEID_INVALID</code> . The returned handle value should always be validated by the caller using the <code>ValidateHandleID()</code> API call to determine success or failure.
Implemented By	Infrastructure
Invoked By	Application, Service, or Device
Notes	<u>The caller should always validate the returned HandleID value using <code>ValidateHandleID()</code> to determine success or failure.</u> After successfully opening a file, data transfer can be performed using the read <u>Read</u> and write <u>Write</u> functions described in sections 4.6.4 <u>12.7.22</u> and <u>12.7.23</u> . For the file access types, which provide the appropriate constraints, see Table 6, Access Constants <u>Values</u> .

Formatted: Font color: Auto

12.80 12.7.28 STI Infrastructure-Provided FileClose Method

STI-78 The STI infrastructure shall provide the `FileClose()` ~~Definition()~~ definition and implementation as specified in ~~Table 62~~ Table 66.

Table 6266: FileClose() Definition

Declaration	Result FileClose(in HandleID fromID, in HandleID toID);
Description	Closes a file handle.
Parameters	<ul style="list-style-type: none"> ▶ <code>fromID</code>: The handle ID of the current component making the request ▶ <code>toID</code>: The handle ID of the file that should be closed
Return	On success, returns <u>OK</u> return the predefined Result value OK. On error <u>Otherwise, returns one</u> return one of the <u>predefined error-Result constants</u> values indicating failure.
Implemented By	Infrastructure
Invoked By	Application, Service, or Device
Notes	The <code>toID</code> parameter should reflect a file handle that was previously obtained using <code>FileOpen()</code> . Behavior is undefined if this function is called with other types of handle IDs.

Formatted: Heading 3, Indent: Left: 0", First line: 0"

Formatted: Border: Top: (No border), Bottom: (No border), Left: (No border), Right: (No border)

Formatted Table

Formatted: Default Paragraph Font, Font: 10.5 pt, Font color: Auto, Pattern: Clear

12.8412.7.29 STI Infrastructure-Provided FileGetSize Method

STI-79 The STI infrastructure shall provide the FileGetSize() ~~Definition()~~ definition and implementation as specified in ~~Table 63~~ Table 67.

Table 6367: FileGetSize() Definition

Declaration	FileSize FileGetSize(in HandleID fromID, in string fileName);
Description	Get the size of the specified file.
Parameters	<ul style="list-style-type: none"> ▶ fromID: The handle ID of the current component making the request ▶ fileName: The name of the file to obtain the size of
Return	On success, returns the <u>return the</u> size of the file. On error, returns return an invalid size.
Implemented By	Infrastructure
Invoked By	Application, Service, or Device
Notes	The return value should be validated by the caller using the ValidateSize() operation as described in section 10.6.1.1 <u>12.7.3</u> .

Formatted: Heading 3, Indent: Left: 0", First line: 0"

Formatted: Border: Top: (No border), Bottom: (No border), Left: (No border), Right: (No border)

12.8212.7.30 STI Infrastructure-Provided FileRemove Method

STI-80 The STI infrastructure shall provide the FileRemove() ~~Definition()~~ definition and implementation as specified in ~~Table 64~~ Table 68.

Table 6468: FileRemove() Definition

Declaration	Result FileRemove(in HandleID fromID, in string fileName);
Description	Removes a specified file from the system.
Parameters	<ul style="list-style-type: none"> ▶ fromID: The handle ID of the current component making the request ▶ fileName: The name of the file to remove
Return	On success, return the predefined Result value OK; otherwise, return one of the predefined Result values indicating failure. See 12.4.6 STI Infrastructure-Provided Result Values. <u>On success, returns OK. On error, returns one of the defined error constants.</u>
Implemented By	Infrastructure
Invoked By	Application, Service, or Device
Notes	Behavior of this function is implementation-defined if the specified file is currently open within the infrastructure. Some systems may support this by "unlinking" the file name but deferring the actual removal (and recovery of space) until the file is closed. On other systems, the function may return an error if the file is currently open. Portable applications should ensure that a file has been closed prior to removal.

Formatted: Heading 3, Indent: Left: 0", First line: 0"

Formatted: Border: Top: (No border), Bottom: (No border), Left: (No border), Right: (No border)

Formatted Table

Formatted: Default Paragraph Font, Font: 10.5 pt, Font color: Auto, Pattern: Clear

12.8312.7.31 STI Infrastructure-Provided FileRename Method

STI-81 The STI infrastructure shall provide the FileRename() ~~Definition()~~ definition and implementation as specified in ~~Table 65~~ Table 69.

Table 6569: FileRename() Definition

Declaration	Result FileRename(in HandleID fromID, in string oldName, in string newName);
Description	Renames a specified file in the file system.
Parameters	<ul style="list-style-type: none"> ▶ fromID: The handle ID of the current component making the request ▶ oldName: The existing/current name of the file ▶ newName: The desired name of the file
Return	<u>On success, return the predefined Result value OK; otherwise, return one of the predefined Result values indicating failure. See 12.4.6 STI Infrastructure-Provided Result Values.</u> On success, returns OK. On error, returns one of the defined error constants.
Implemented By	Infrastructure
Invoked By	Application, Service, or Device
Notes	Behavior of this function is implementation-defined if the specified file is currently open within the infrastructure. Some systems may support renaming an open file, but on other systems the function may return an error. Portable applications should ensure that a file has been closed prior to rename.

Formatted: Heading 3, Indent: Left: 0", First line: 0"

Formatted: Border: Top: (No border), Bottom: (No border), Left: (No border), Right: (No border)

12.8412.7.32 STI Infrastructure-Provided FileGetFreeSpace Method

STI-82 The STI infrastructure shall provide the FileGetFreeSpace() ~~Definition()~~ definition and implementation as specified in ~~Table 66~~ Table 70.

Table 6670: FileGetFreeSpace() Definition

Declaration	FileSize FileGetFreeSpace(in HandleID fromID, in string fileSystem);
Description	Get the total free space available for file storage on the indicated file system.
Parameters	<ul style="list-style-type: none"> ▶ fromID: The handle ID of the current component making the request ▶ fileSystem: Identifies the file system to check
Return	On success, returns the <u>return the</u> amount of free space. On error, returns <u>return</u> an invalid size.
Implemented By	Infrastructure
Invoked By	Application, Service, or Device

Formatted: Heading 3, Indent: Left: 0", First line: 0"

Formatted: Border: Top: (No border), Bottom: (No border), Left: (No border), Right: (No border)

Formatted Table

Formatted: Default Paragraph Font, Font: 10.5 pt, Font color: Auto, Pattern: Clear

Notes	The specific format and options for the fileSystem parameter will be defined by the platform provider. An invalid (undefined/NULL) or empty string value should always be interpreted to refer to the “default” or root storage device, if available. A non-empty string may refer to a physical device name, drive identifier, or a mount point, depending on the system.
-------	--

12.8512.7.33 STI Infrastructure-Provided MessageQueueCreate Method

STI-83 The STI infrastructure shall provide the MessageQueueCreate() ~~Definition()~~ definition and implementation as specified in ~~Table 67~~ Table 71.

Table 671: MessageQueueCreate() Definition

Declaration	HandleID MessageQueueCreate(in HandleID fromID, in string queueName, in QueueMaxMessages nmax, in <u>BufferSize-Integer</u> nb);
Description	Create a FIFO message queue.
Parameters	<ul style="list-style-type: none"> ▶ fromID: The handle ID of the current component making the request ▶ queueName: The name of the queue to create ▶ nmax: The maximum number of messages (depth) of the FIFO queue ▶ nb: The maximum size of each entry in the queue
Return	On success, returns <u>return</u> a Handle ID value identifying the FIFO queue. On error <u>Otherwise, return an invalid handle ID value is returned</u> the predefined <u>HANDLEID_INVALID</u> . The returned handle value should always be validated by the caller using the ValidateHandleID() API call to determine success or failure.
Implemented-By	Infrastructure
Invoked-By	Application, Service, or Device
Notes	<p><u>The returned handle value should always be validated by the caller using ValidateHandleID() to determine success or failure.</u></p> <p>The queue name will be unique in within the current environment.</p> <p>Once a queue depth reaches its maximum (nmax), applications will be unable to write new data into the queue. Data does not “expire” from a FIFO queue; any data successfully written to the input side of a queue is removed only by reading the data from the output side of the queue, or by deleting the entire queue.</p> <p>If the nb parameter is omitted or specified as 0, the interpretation is implementation-defined. Specifically, this may be used for languages that employ automatic memory management and do not expose the size of objects in memory to applications.</p>

Formatted: Heading 3, Indent: Left: 0", First line: 0"

Formatted: Border: Top: (No border), Bottom: (No border), Left: (No border), Right: (No border)

Formatted: Border: Top: (No border), Bottom: (No border), Left: (No border), Right: (No border)

12.8612.7.34 STI Infrastructure-Provided MessageQueueDelete Method

STI-84 The STI infrastructure shall provide the MessageQueueDelete() ~~Definition()~~ definition and implementation as specified in ~~Table 68~~ Table 72.

Formatted: Heading 3, Indent: Left: 0", First line: 0"

Formatted: Default Paragraph Font, Font: 10.5 pt, Font color: Auto, Pattern: Clear

Table 6872: MessageQueueDelete() Definition

Declaration	Result MessageQueueDelete(in HandleID fromID, in HandleID toID);
Description	Delete a FIFO queue.
Parameters	<ul style="list-style-type: none"> ▶ fromID: The handle ID of the current component making the request ▶ toID: The handle ID of the queue that should be deleted
Return	<u>On success, return the predefined Result value OK; otherwise, return one of the predefined Result values indicating failure. See 12.4.6 STI Infrastructure-Provided Result Values. On success, returns OK. On error, returns one of the defined error constants.</u>
Implemented By	Infrastructure
Invoked By	Application, Service, or Device
Notes	Any written but unread data messages in the queue are discarded.

Formatted: Border: Top: (No border), Bottom: (No border), Left: (No border), Right: (No border)

Formatted Table

12.8712.7.35 STI Infrastructure-Provided PubSubCreate Method

STI-85 The STI infrastructure shall provide the PubSubCreate() ~~Definition ()~~ definition and implementation as specified in ~~Table 69~~Table 73.

Table 6973: PubSubCreate() Definition

Declaration	HandleID PubSubCreate(in HandleID fromID, in string pubSubName);
Description	Create a PubSub entity.
Parameters	<ul style="list-style-type: none"> ▶ fromID: The handle ID of the current component making the request ▶ pubSubName: The name of the PubSub entity to be created
Return	<u>On success, returns return a Handle ID value identifying the PubSub entity. On error, otherwise, return the predefined an invalid handle ID value is returned HANDLEID_INVALID. The returned handle value should always be validated by the caller using the ValidateHandleID() API call to determine success or failure.</u>
Implemented By	Infrastructure
Invoked By	Application, Service, or Device
Notes	<p><u>The returned handle value should always be validated by the caller using ValidateHandleID() to determine success or failure.</u></p> <p>The name will be unique in within the current environment.</p> <p>Unlike FIFO queues, PubSub entities do not store messages; any messages pushed to a PubSub entity are immediately distributed to all currently registered subscribers at the time the message is pushed.</p>

Formatted: Heading 3, Indent: Left: 0", First line: 0"

Formatted: Border: Top: (No border), Bottom: (No border), Left: (No border), Right: (No border)

Formatted: Default Paragraph Font, Font: 10.5 pt, Font color: Auto, Pattern: Clear

12.8812.7.36 STI Infrastructure-Provided PubSubDelete Method

STI-86 The STI infrastructure shall provide the PubSubDelete(~~Definition()~~ definition and implementation as specified in ~~Table 70~~Table 74.

Table 7074: PubSubDelete() Definition

Declaration	Result PubSubDelete(in HandleID fromID, in HandleID toID);
Description	Delete a PubSub entity.
Parameters	<ul style="list-style-type: none"> ▶ fromID: The handle ID of the current component making the request ▶ toID: The handle ID of the PubSub entity to be deleted
Return	On success, returns OK. On error, returns one of the defined error constants. <u>On success, return the predefined Result value OK; otherwise, return one of the predefined Result values indicating failure. See 12.4.6 STI Infrastructure-Provided Result Values.</u>
Implemented By	Infrastructure
Invoked By	Application, Service, or Device
Notes	Any registered subscribers will be automatically unregistered upon deletion.

Formatted: Heading 3, Indent: Left: 0", First line: 0"

Formatted: Border: Top: (No border), Bottom: (No border), Left: (No border), Right: (No border)

Formatted Table

12.8912.7.37 STI Infrastructure-Provided Register Method

STI-87 The STI infrastructure shall provide the Register(~~Definition()~~ definition and implementation as specified in ~~Table 74~~Table 75.

Table 7475: Register() Definition

Declaration	Result Register(in HandleID fromID, in HandleID toID, in HandleID recipientID);
Description	Add a handle to the recipient list of the PubSub entity.
Parameters	<ul style="list-style-type: none"> ▶ fromID: The handle ID of the current component making the request ▶ toID: The handle ID of the PubSub entity ▶ recipientID: The handle ID of another application, device, file, or queue that should receive all messages written to the PubSub entity
Return	On success, returns OK. On error, returns one of the defined error constants. <u>On success, return the predefined Result value OK; otherwise, return one of the predefined Result values indicating failure. See 12.4.6 STI Infrastructure-Provided Result Values.</u>
Implemented By	Infrastructure
Invoked By	Application, Service, or Device

Formatted: Heading 3, Indent: Left: 0", First line: 0"

Formatted: Border: Top: (No border), Bottom: (No border), Left: (No border), Right: (No border)

Formatted: Default Paragraph Font, Font: 10.5 pt, Font color: Auto, Pattern: Clear

Notes	A single recipient cannot be registered multiple times. If a recipient is already registered within the PubSub entity, this function returns a success code without making any change.
--------------	--

12.9012.7.38 STI Infrastructure-Provided Unregister Method

STI-88 The STI infrastructure shall provide the Unregister() ~~Definition()~~ definition and implementation as specified in ~~Table 72~~ Table 76.

Table 7276: Unregister() Definition

Declaration	Result Unregister(in HandleID fromID, in HandleID toID, in HandleID recipientID);
Description	Remove a handle from the recipient list of the PubSub entity.
Parameters	<ul style="list-style-type: none"> ▶ fromID: The handle ID of the current component making the request ▶ toID: The handle ID of the PubSub entity ▶ recipientID: The handle ID of the other application, device, file, or queue that should no longer receive messages written to the PubSub entity
Return	On success, return the predefined Result value OK; otherwise, return one of the predefined Result values indicating failure. See 12.4.6 STI Infrastructure-Provided Result Values. <u>On success, returns OK. On error, returns one of the defined error constants.</u>
Implemented By	Infrastructure
Invoked By	Application, Service, or Device
Notes	

Formatted: Heading 3, Indent: Left: 0", First line: 0"

Formatted: Border: Top: (No border), Bottom: (No border), Left: (No border), Right: (No border)

Formatted Table

12.9412.7.39 STI Infrastructure-Provided GetNanoseconds Method

STI-89 The STI infrastructure shall provide the GetNanoseconds() ~~Definition()~~ definition and implementation as specified in ~~Table 73~~ Table 77.

Table 7377: GetNanoseconds() Definition

Declaration	Nanoseconds GetNanoseconds(in TimeWarp twObj);
Description	Get the number of nanoseconds (fractional quantity) from the TimeWarp object.
Parameters	▶ twObj: The value from which the nanoseconds portion of the time is extracted
Return	Returns the <u>Return the</u> number of nanoseconds
Implemented By	Infrastructure
Invoked By	Application, Service, or Device

Formatted: Heading 3, Indent: Left: 0", First line: 0"

Formatted: Border: Top: (No border), Bottom: (No border), Left: (No border), Right: (No border)

Formatted: Default Paragraph Font, Font: 10.5 pt, Font color: Auto, Pattern: Clear

Notes	The nanoseconds value is always non-negative, and reflects the difference between the actual interval time and the number of whole seconds in the interval as reported by <code>GetSeconds()</code>
--------------	---

12.9212.7.40 STI Infrastructure-Provided GetSeconds Method

STI-90 The STI infrastructure shall provide the `GetSeconds()` ~~Definition()~~ definition and implementation as specified in ~~Table 74~~Table 78.

Table 7478: `GetSeconds()` Definition

Declaration	Seconds <code>GetSeconds()</code> in <code>TimeWarp twObj</code>);
Description	Get the number of seconds (whole number quantity) from the <code>TimeWarp</code> object.
Parameters	► <code>twObj</code> : The value from which the seconds portion of the time is extracted
Return	Returns the <u>Return the</u> number of seconds
Implemented By	Infrastructure
Invoked By	Application, Service, or Device
Notes	The seconds value may be negative, which indicates an interval back in time. For fractional intervals, the seconds value reflects the largest integral value not greater than the interval length in seconds, similar to the POSIX <code>floor()</code> operation applied to a floating-point value. For example, given a <code>TimeWarp</code> interval corresponding to <code>-1.1s</code> , the <code>GetSeconds()</code> function will return <code>-2</code> , and the <code>GetNanoseconds()</code> function will return <code>900,000,000</code> .

Formatted: Heading 3, Indent: Left: 0", First line: 0"

Formatted: Border: Top: (No border), Bottom: (No border), Left: (No border), Right: (No border)

12.9312.7.41 STI Infrastructure-Provided GetTimeWarp Method

STI-91 The STI infrastructure shall provide the `GetTimeWarp()` ~~Definition()~~ definition and implementation as specified in ~~Table 75~~Table 79.

Table 7579: `GetTimeWarp()` Definition

Declaration	<code>TimeWarp GetTimeWarp()</code> in Seconds <code>isec</code> , in Nanoseconds <code>nsec</code>);
Description	Get the <code>TimeWarp</code> object value corresponding to the seconds and nanoseconds.
Parameters	► <code>isec</code> : The number of seconds in the time interval (whole number portion) ► <code>nsec</code> : The number of nanoseconds in the time interval (fractional portion)
Return	Returns the <u>Return the</u> corresponding time value as a <code>TimeWarp</code> value
Implemented By	Infrastructure
Invoked By	Application, Service, or Device

Formatted: Heading 3, Indent: Left: 0", First line: 0"

Formatted: Border: Top: (No border), Bottom: (No border), Left: (No border), Right: (No border)

Formatted: Default Paragraph Font, Font: 10.5 pt, Font color: Auto, Pattern: Clear

Notes	The <code>nsec</code> parameter value should be between 0 and 999,999,999, inclusive. If the <code>nsec</code> value is not within this range, the infrastructure should adjust the <code>isec</code> and <code>nsec</code> values by decrementing/incrementing <code>nsec</code> by 1,000,000,000 and incrementing/decrementing <code>isec</code> by 1, respectively, until the <code>nsec</code> value is within this range.
--------------	--

12.9412.7.42 STI Infrastructure-Provided TimeAdd Method

STI-92 The STI infrastructure shall provide the `TimeAdd()` [Definition\(\)](#) [definition and implementation](#) as specified in [Table 76](#)[Table 80](#).

Table 7680: TimeAdd() Definition

Declaration	TimeWarp TimeAdd(in TimeWarp t1, in TimeWarp t2);
Description	Compute the sum of two TimeWarp values.
Parameters	► t1, t2: Any previously obtained time values
Return	The sum (t1 + t2) expressed as a TimeWarp value
Implemented-By	Infrastructure
Invoked-By	Application, Service, or Device
Notes	

Formatted: Heading 3, Indent: Left: 0", First line: 0"

Formatted: Border: Top: (No border), Bottom: (No border), Left: (No border), Right: (No border)

12.9512.7.43 STI Infrastructure-Provided TimeSubtract Method

STI-93 The STI infrastructure shall provide the `TimeSubtract()` [Definition\(\)](#) [definition and implementation](#) as specified in [Table 77](#)[Table 81](#).

Table 7781: TimeSubtract() Definition

Declaration	TimeWarp TimeSubtract(in TimeWarp t1, in TimeWarp t2);
Description	Compute the difference between two TimeWarp values.
Parameters	► t1, t2: Any previously obtained time values
Return	The difference (t1 - t2) expressed as a TimeWarp value
Implemented-By	Infrastructure
Invoked-By	Application, Service, or Device

Formatted: Heading 3, Indent: Left: 0", First line: 0"

Formatted: Border: Top: (No border), Bottom: (No border), Left: (No border), Right: (No border)

Formatted Table

Formatted: Default Paragraph Font, Font: 10.5 pt, Font color: Auto, Pattern: Clear

Notes	This operation may be implemented as a macro or inline function for efficiency, on languages that offer this feature. This operation may be used by software to compute the elapsed time between two successive calls to <code>GetTime()</code> . The result can be converted back to engineering units via the <code>GetSeconds()</code> and <code>GetNanoseconds()</code> operations
--------------	---

12.9612.7.44 STI Infrastructure-Provided GetTime Method

STI-94 The STI infrastructure shall provide the `GetTime()` [Definition\(\)](#) [-definition and implementation](#) as specified in [Table 78](#)[Table 82](#).

Table 7882: `GetTime()` Definition

Declaration	Result <code>GetTime</code> (in <code>HandleID</code> fromID, in <code>HandleID</code> toID, out <code>TimeWarp</code> currentTime);
Description	Obtains the current value of the clock.
Parameters	<ul style="list-style-type: none"> ▶ <code>fromID</code>: The handle ID of the current component making the request ▶ <code>toID</code>: The handle ID of the clock device/clock component that should respond to the request ▶ <code>currentTime</code>: A buffer to store the current time, as an interval since the epoch
Return	On success, return the predefined Result value OK; otherwise, return one of the predefined Result values indicating failure. See 12.4.6 STI Infrastructure-Provided Result Values. On success, returns OK. On error, returns one of the defined error constants.
Implemented By	Infrastructure
Invoked By	Application, Service, or Device
Notes	The output value returned represents a direct measurement of elapsed time since its respective epoch according to the clock's time scale and is not adjusted for nor dependent upon any locale-specific time representations (i.e. time zone, daylight savings time, etc.) or effects of relativity.

Formatted: Heading 3, Indent: Left: 0", First line: 0"

Formatted: Border: Top: (No border), Bottom: (No border), Left: (No border), Right: (No border)

12.9712.7.45 STI Infrastructure-Provided SetTime Method

STI-95 The STI infrastructure shall provide the `SetTime()` [Definition\(\)](#) [-definition and implementation](#) as specified in [Table 79](#)[Table 83](#).

Table 7983: `SetTime()` Definition

Declaration	Result <code>SetTime</code> (in <code>HandleID</code> fromID, in <code>HandleID</code> toID, in <code>TimeWarp</code> deltaTime);
Description	Sets the current value of the clock.

Formatted: Heading 3, Indent: Left: 0", First line: 0"

Formatted: Border: Top: (No border), Bottom: (No border), Left: (No border), Right: (No border)

Formatted: Default Paragraph Font, Font: 10.5 pt, Font color: Auto, Pattern: Clear

Parameters	<ul style="list-style-type: none"> ▶ fromID: The handle ID of the current component making the request ▶ toID: The handle ID of the <code>eClockDeviceClockComponent</code> that should respond to the request ▶ deltaTime: The step size, relative to the current clock value
Return	On success, return the predefined Result value OK; otherwise, return one of the predefined Result values indicating failure. See 12.4.6 STI Infrastructure-Provided Result Values. On success, returns OK. On error, returns one of the defined error constants.
Implemented By	Infrastructure
Invoked By	Application, Service, or Device
Notes	<p>This function will “step” the base clock. Since the offset is applied against the base clock measurement, it affects all calendar representations of the clock accordingly. It may be used to synchronize a clock based on information obtained after start up.</p> <p>Not all <code>eClockDeviceClockComponents</code> are required to support this operation. If a <code>eClockDeviceClockComponent</code> is read-only and not settable from an application, this function should return UNIMPLEMENTED.</p> <p>Note that this is not intended for implementing the concept of a “time zone” or “local time” (i.e. the time as commonly expressed in a given geopolitical region). If the platform implements the concept of local time, then the specific local time offset or conversion rules should be configured using the <code>PropertySetAPIConfigure and Query methods</code> as described in sections 10.6.2.3, 12.7.11 and 12.7.12.</p> <p>The specific property name and value format for time zone configuration is platform-defined. On some systems, it may be directly configured as a number (i.e. minutes ahead of GMT) or it may be configured as a string reflecting a predefined rule (i.e. “US/Eastern”) if the system is capable of automatic daylight savings time adjustments.</p>

Formatted Table

12.98 12.7.46 STI Infrastructure-Provided GetCalendarTime Method

STI-96 The STI infrastructure shall provide the `GetCalendarTime()` Definition () -definition and implementation as specified in Table 80 Table 84.

Table 80 Table 84: GetCalendarTime() Definition

Declaration	<pre>Result GetCalendarTime(in HandleID fromID, in HandleID toID, in TimeWarp referenceTime, in CalendarKind calendarKind, out CalendarTime calendarTime);</pre>
Description	Convert the base clock time value to a defined calendar representation.
Parameters	<ul style="list-style-type: none"> ▶ fromID: The handle ID of the current component making the request ▶ toID: The handle ID of the clock device that should respond to the request ▶ referenceTime: The time to convert, expressed as an interval since the clock epoch ▶ calendarKind: The calendar system to convert the reference time to ▶ calendarTime: A buffer to store the calendar representation of the reference time

Formatted: Heading 3, Indent: Left: 0", First line: 0"

Formatted: Border: Top: (No border), Bottom: (No border), Left: (No border), Right: (No border)

Formatted: Default Paragraph Font, Font: 10.5 pt, Font color: Auto, Pattern: Clear

Return	On success, return the predefined Result value OK; otherwise, return one of the predefined Result values indicating failure. See 12.4.6 STI Infrastructure-Provided Result Values. On success, returns OK. On error, returns one of the defined error constants.
Implemented By	Infrastructure
Invoked By	Application, Service, or Device
Notes	This call is used by applications to convert an abstract TimeWarp value (of which the definition is platform-specific) into a value in one of the defined calendar systems, such that portable applications can interpret it in a consistent manner. If the system or clock does not support the requested calendarKind, the implementation should return UNIMPLEMENTED. If the referenceTime is zero, such as the result of a call to GetTimeWarp(0, 0) then this will return the respective calendar representation of the clock epoch.

12.99 STI Infrastructure-Provided CalendarValueCivil Structure

STI-97 The STI infrastructure shall provide the CalendarValueCivil Structure Definition as specified in Table 81.

Table 81: CalendarValueCivil Structure Definition

Declaration	<pre>struct CalendarValueCivil { long nanoseconds; octet seconds; octet minutes; octet hours; octet day; octet month; short year; };</pre>
Description	Definition of time representation type for the common era / Gregorian calendar
Member Details	<ul style="list-style-type: none"> ▶ nanoseconds: The number of nanoseconds, range of [0-999999999] ▶ seconds: The seconds value, range of [0-60] ▶ minutes: The minutes value, range of [0-59] ▶ hours: The hours value, range of [0-23] ▶ day: The day number within the month, range of [0-30] ▶ month: The month number within the year, range of [0-11] ▶ year: The full year number, expressed as an integer (i.e. 2019)
Implemented By	Infrastructure
Notes	This format is applicable to UTC and, usually, the local time representations. For local time representations, the specific offset from UTC and daylight savings configuration should be configured or queried separately through the property set interface. The nanoseconds field is intended to support applications that require higher precision time values. This does not imply that the underlying clock has nanosecond precision. For clocks that do not support higher precision timing, this field should always be set as zero.

Formatted: Heading 3, Indent: Left: 0", First line: 0"

Formatted: Default Paragraph Font, Font: 10.5 pt, Font color: Auto, Pattern: Clear

12.100 — STI Infrastructure Provided CalendarValueGPS Structure

STI-98 The STI infrastructure shall provide the CalendarValueGPS Structure Definition as specified in Table 82.
Table 82: CalendarValueGPS Structure Definition

Declaration	<pre>struct CalendarValueGPS { long tow; short week; };</pre>
Description	Definition of time representation expressed in weeks and seconds, similar to the style used in GPS navigation messages
Member Details	<ul style="list-style-type: none"> ▶ <code>tow</code>: The time of week in milliseconds, range of [0-604799999] ▶ <code>week</code>: The number of weeks elapsed since the epoch
Implemented By	Infrastructure
Notes	<p>This is not an exact representation of GPS time codes, but rather a method of expressing time in terms that facilitate easy conversion to/from actual GPS navigation code formats while also providing higher precision.</p> <p>Legacy GPS navigation signals express the week number as a 10-bit integer, which rolls over every 1024 weeks, with time of week expressed as a 19-bit integer with 1.5-second resolution. Other navigation signals have a different format, using 13-bit week number along with a 2-hour interval time of week and 18-second time of interval.</p> <p>This structure expresses the time of week value in units of milliseconds. Conversion from legacy GPS time of week values is accomplished via multiplication by 1500 (1.5 seconds), and conversion from 18-second time of interval codes is accomplished via multiplication by 18000. Likewise, a conversion to whole seconds can be achieved by dividing the <code>tow</code> by 1000, and the day of week can be determined by dividing by 86400000.</p>

Formatted: Heading 3, Indent: Left: 0", First line: 0"

Formatted: Text body, Space Before: 0 pt

12.101 — STI Infrastructure Provided CalendarValueDayNumber Structure

STI-99 The STI infrastructure shall provide the CalendarValueDayNumber Structure Definition as specified in Table 83.

Table 83: CalendarValueDayNumber Structure Definition

Declaration	<pre>struct CalendarValueDayNumber { double date; };</pre>
Description	Definition of time representation expressed as a fractional day number
Member Details	▶ <code>date</code> : The day number expressed as a fractional / floating point value
Implemented By	Infrastructure
Notes	The whole number (integer portion) of the value expresses the number of Earth days since the epoch, and the fractional part expresses the time of day.

Formatted: Heading 3, Indent: Left: 0", First line: 0"

Formatted: Text body, Space Before: 0 pt

12.102 — STI Infrastructure Provided CalendarTime Union

STI-100 The STI infrastructure shall provide the CalendarTime Union Definition as specified in Table 84.

Formatted: Heading 3, Indent: Left: 0", First line: 0"

Formatted: Default Paragraph Font, Font: 10.5 pt, Font color: Auto, Pattern: Clear

Table 84: CalendarTime Union Definition

Declaration	<pre> union CalendarTime switch(CalendarKind) { case MJD: CalendarValueDayNumber dayNumber; case GPS: CalendarValueGPS weekSeconds; case LOCAL: CalendarValueCivil local; case TAI: CalendarValueCivil tai; case UTC: CalendarValueCivil civil; }; </pre>
Description	Definition of CalendarTime type based on CalendarKind value
Implemented By	Infrastructure
Invoked By	Application, Service, or Device
Notes	

Formatted: Text body, Space Before: 0 pt

12.40312.7.47 STI Infrastructure-Provided SetTimeAdjust Method

STI-101 The STI infrastructure shall provide the SetTimeAdjust() Definition-() definition and implementation as specified in Table 85.

Table 1685: SetTimeAdjust() Definition

Declaration	<pre> Result SetTimeAdjust(in HandleID fromID, in HandleID toID, in TimeRate rateAdjustment); </pre>
Description	Adjusts the tick rate of the clock device/clock component.
Parameters	<ul style="list-style-type: none"> ▶ fromID: The handle ID of the current component making the request ▶ toID: The handle ID of the clock device/clock component that should respond to the request ▶ rateAdjustment: The amount of adjustment to apply
Return	On success, return the predefined Result value OK; otherwise, return one of the predefined Result values indicating failure. See 12.4.6 STI Infrastructure-Provided Result Values. On success, returns OK. On error, returns one of the defined error constants.
Implemented By	Infrastructure
Invoked By	Application, Service, or Device

Formatted: Heading 3, Indent: Left: 0", First line: 0"

Formatted: Border: Top: (No border), Bottom: (No border), Left: (No border), Right: (No border)

Formatted: Default Paragraph Font, Font: 10.5 pt, Font color: Auto, Pattern: Clear

Notes	<p>The <code>rateAdjustment</code> parameter is a signed integer, where the value of 0 represents the nominal or free-run rate of the clock without any adjustment applied. If any adjustment had been previously applied, calling this function with a value of 0 will restore a clock to its default rate.</p> <p>A positive value will cause the clock frequency to increase from the nominal rate, and a negative value will cause the clock frequency to decrease from the nominal rate. The specific unit of rate increase/decrease is platform defined, although typically might reflect a number of parts per million or parts per billion depending on clock design.</p> <p>If the underlying device does not support rate adjustment, then this function will return the <code>predefined Result value_UNIMPLEMENTED</code> status code.</p> <p>A typical use-case of this function would periodically compute the difference between the reference clock and the local <code>clock-device-clock component</code>, which is then multiplied by a feedback ratio (proportional coefficient) to compute the adjustment value to pass into this function.</p>
--------------	--

12.10412.7.48 STI Infrastructure-Provided GetTimeAdjust Method

STI-102 The STI infrastructure shall provide the `GetTimeAdjust()` ~~Definition()~~ definition and implementation as specified in Table 86.

Table 1786: `GetTimeAdjust()` Definition

Declaration	<pre>TimeRate GetTimeAdjust(in HandleID fromID, in HandleID toID);</pre>
Description	Obtain the current tick rate adjustment value of the <code>clock-device-clock component</code> .
Parameters	<ul style="list-style-type: none"> ▶ <code>fromID</code>: The handle ID of the current component making the request ▶ <code>toID</code>: The handle ID of the <code>clock-device-clock -component</code> that should respond to the request
Return	Returns the <u>Return</u> the current tick rate adjustment value
Implemented By	Infrastructure
Invoked By	Application, Service, or Device
Notes	<p>A return value of 0 indicates the clock is operating at its nominal or free-run frequency. If the underlying device does not support rate adjustment, then this function always returns 0.</p> <p>A positive value indicates the clock frequency is above nominal, and a negative value indicates the clock frequency is below nominal.</p> <p>The specific units of the <code>TimeRate</code> value are platform defined, although typically might reflect a number of parts per million or parts per billion depending on clock design.</p>

Formatted: Heading 3, Indent: Left: 0", First line: 0"

Formatted: Border: Top: (No border), Bottom: (No border), Left: (No border), Right: (No border)

Formatted Table

12.10512.7.49 STI Infrastructure-Provided TimeSynch Method

STI-103 The STI infrastructure shall provide the `TimeSynch()` ~~Definition()~~ definition and implementation as specified in Table 87.

Table 1887: `TimeSynch()` Definition

Formatted: Heading 3, Indent: Left: 0", First line: 0"

Formatted: Default Paragraph Font, Font: 10.5 pt, Font color: Auto, Pattern: Clear

Declaration	Result TimeSynch(in HandleID fromID, in HandleID toID, in HandleID referenceID, in TimeWarp stepMax);
Description	Synchronizes <u>a one clock deviceclock -component</u> with another <u>waveform or deviceclock component in the system</u> .
Parameters	<ul style="list-style-type: none"> ▶ fromID: The handle ID of the current component making the request ▶ toID: The handle ID of the <u>clock deviceclock -component</u> that should respond to the request ▶ referenceID: The handle ID of another <u>device or waveformclock component in the system</u> that provides a synchronization source for the target <u>clock deviceclock component</u>. ▶ stepMax: The maximum amount that the target clock should be modified. <u>A value of either TIME_INTERVAL_ZERO or TIME_INTERVAL_UNLIMITED indicates no limit to the maximum step size.</u>
Return	<p><u>If the synchronization is successful with a single call to TimeSynch(), such that no further action is required, return the predefined Result value OK.</u></p> <p><u>If the synchronization is partially successful such that additional calls to TimeSynch() are required, due to constraints such as those imposed by stepMax, return a positive integer value indicating the anticipated number of calls required.</u></p> <p><u>If synchronization is not possible under the given constraints, return one of the predefined Result values indicating failure. See 12.4.6 STI Infrastructure-Provided Result Values. A status code that should be checked using ISOK().</u></p> <p><u>If the synchronization is successful with a single call to TimeSynch(), such that no further action is required, the implementation will return OK.</u></p> <p><u>If the synchronization is successful but requires multiple calls (e.g. due to constraints imposed by stepMax) the implementation will return a positive integer value indicating the anticipated number of calls required.</u></p> <p><u>If synchronization is not possible under the given constraints the implementation will return a suitable error response.</u></p>
Implemented By	Infrastructure
Invoked By	Application, Service, or Device

Formatted: Border: Top: (No border), Bottom: (No border), Left: (No border), Right: (No border)

Commented [HLM(L44): [JIRA issue STI_19: Typo "TIME_INTERVAL_MAX" should be "TIME_INTERVAL_UNLIMITED"](#)

Formatted Table

Formatted: Default Paragraph Font, Font: 10.5 pt, Font color: Auto, Pattern: Clear

Notes	<p>This function is intended for use in systems where a local general-purpose clock/timer service<u>one clock component</u> may be selectively synchronized with other devices<u>another clock component on the system</u>. Support for this function is implementation-defined, and this function may return <u>the predefined value</u> UNIMPLEMENTED if the <u>clock device</u>clock component does not support synchronization with any other devices<u>clock component</u>.</p> <p>The infrastructure provider will document the set of <u>applications</u>, <u>devices</u>, or services suitable for use with the referenceID parameter. This reference device<u>synchronizable clock components with a handle ID parameter</u>. This <u>reference clock component</u> may be another infrastructure-provided clock/timer service, or it may be another form of timing reference, such as a software service implementing a protocol such as NTP or IEEE-1588, or a device capable of recovering timing signals from received bit streams.</p> <p>The <u>stepMax</u> parameter specifies the maximum amount that the target <u>clock device</u>clock component may be modified in a single step change. The <u>constant predefined</u> TIME_INTERVAL_UNLIMITED <u>value</u> may be specified to indicate no limit to the step size, permitting the target <u>device</u>clock component to be directly set to any value.</p>
--------------	---

Formatted: Font: (Default) Times New Roman, 10 pt, Font color: Auto, Pattern: Clear

12.10612.7.50 STI Infrastructure-Provided Sleep Method

STI-104 The STI infrastructure shall provide the Sleep() ~~Definition()~~definition and implementation as specified in Table 88.

Formatted: Heading 3, Indent: Left: 0", First line: 0"

Table 1988: Sleep() Definition

Declaration	<pre>Result Sleep(in HandleID fromID, in HandleID toID, in TimeWarp interval);</pre>
Description	<p>Delays the caller until the specified interval has elapsed, as measured by the <u>clock device</u>clock component.</p>
Parameters	<ul style="list-style-type: none"> ▶ <u>fromID</u>: The handle ID of the current component making the request ▶ <u>toID</u>: The handle ID of the <u>clock device</u>clock component that should respond to the request ▶ <u>interval</u>: The amount of time that the caller should be delayed, relative to the current clock value
Return	<p>On success, return the predefined Result value OK; otherwise, return one of the predefined Result values indicating failure. See 12.4.6 STI Infrastructure-Provided Result Values. On success, returns OK. On error, returns one of the defined error constants.</p>
Implemented By	<p>Infrastructure</p>
Invoked By	<p>Application, Service, or Device</p>

Formatted: Border: Top: (No border), Bottom: (No border), Left: (No border), Right: (No border)

Formatted: Default Paragraph Font, Font: 10.5 pt, Font color: Auto, Pattern: Clear

Notes	<p>The call may be interrupted under some circumstances, causing the infrastructure to return to the caller before the interval has elapsed. In these cases, the infrastructure should return the <code>WARNING</code> response.</p> <p>Note that the actual sleep time may be longer than requested due to the resolution of the <code>clock-deviceclock-component</code> and operating system scheduling variances.</p> <p>Setting a clock using <code>SetTime()</code> while this operation is in progress has undefined effects on the delay operation.</p>
--------------	---

12.10712.7.51 STI Infrastructure-Provided DelayUntil Method

STI-105 The STI infrastructure shall provide the `DelayUntil()` definition and implementation as specified in Table 89.

Table 2089: DelayUntil() Definition

Declaration	<pre>Result DelayUntil(in HandleID fromID, in HandleID toID, in TimeWarp endTime);</pre>
Description	Delays the caller until the clock reaches the indicated value.
Parameters	<ul style="list-style-type: none"> ▶ <code>fromID</code>: The handle ID of the current component making the request ▶ <code>toID</code>: The handle ID of the component that should respond to the request ▶ <code>endTime</code>: The time value at which the function should return, relative to the clock epoch
Return	<p>On success, return the predefined Result value <code>OK</code>; otherwise, return one of the predefined Result values indicating failure. See 12.4.6 STI Infrastructure-Provided Result Values. On success, returns <code>OK</code>. On error, returns one of the defined error constants.</p>
Implemented By	Infrastructure
Invoked By	Application, Service, or Device
Notes	<p>The call may be interrupted under some circumstances, causing the infrastructure to return to the caller before the end time has been reached. In these cases, the infrastructure should return the <code>WARNING</code> response.</p> <p>Note that the actual sleep time may be longer than requested due to the resolution of the <code>clock-deviceclock-component</code> and operating system scheduling variances.</p> <p>Setting a clock using <code>SetTime()</code> while this operation is in progress has undefined effects on the delay operation.</p>

Formatted: Heading 3, Indent: Left: 0", First line: 0"

Formatted: Border: Top: (No border), Bottom: (No border), Left: (No border), Right: (No border)

12.7.52 STI Infrastructure-Provided ConvertToTimeWarp Method

STI-112 The STI infrastructure shall provide the `ConvertToTimeWarp()` definition and implementation as specified in Table 90.

Table 90: ConvertToTimeWarp() Definition

Declaration	<pre>Result ConvertToTimeWarp(in HandleID fromID, in CalendarKind calendarKind,</pre>
--------------------	--

Commented [HLM(L45): JIRA issue STI 78: Missing Clock Methods]

Formatted: Font: 12 pt

Formatted: Font: 12 pt

Formatted: Font: (Default) Times New Roman, 10 pt, Not Bold, Font color: Auto

Formatted: Table, Space Before: 9 pt

Formatted: Font: 10 pt

Formatted: Interface Heading, Left

Formatted Table

Formatted: Font: 10 pt, Not Bold

Formatted: Default Paragraph Font, Font: 10.5 pt, Font color: Auto, Pattern: Clear

	<pre> in CalendarTime calendarTime, out TimeWarp twTime); </pre>
Description	Convert the defined calendar representation to a TimeWarp clock time value.
Parameters	<ul style="list-style-type: none"> ▶ <code>fromID</code>: The handle ID of the current component making the request ▶ <code>calendarKind</code>: The calendar system of the calendar time to be converted ▶ <code>calendarTime</code>: A buffer to store the calendar representation of the calendar time to be converted ▶ <code>twTime</code>: The converted time, expressed as an interval since the clock epoch
Return	On success, return the predefined Result value OK. On error, return one of the predefined Result values indicating failure. See 12.4.6 STI Infrastructure-Provided Result Values.
Notes	This call is used by applications to convert a value in one of the defined calendar systems into a TimeWarp value (of which the definition is platform-specific), such that portable applications can interpret it in a consistent manner. If the system or clock does not support the requested calendarKind, the implementation should return UNIMPLEMENTED. If the calendarTime is prior to the epoch for TimeWarp, an error is returned.

12.108 Document STI Interfaces

STI-106 The STI infrastructure provider shall document the set of interfaces provided by the infrastructure.

12.109 Document Application's System Library Interfaces

STI-107 The STI application developer shall document the set of operating system interfaces required by the application.

12.8 External Command and Telemetry

12.110 12.8.1 Respond to External Commands

STI-108 An STI platform shall accept, validate, and respond to external commands.

12.111 12.8.2 External Commands Use STI API

STI-109 An STI platform shall execute external application control commands using the standardized STI APIs.

12.112 12.8.3 Document External Commands

STI-110 An STI platform provider shall document any external commands describing their format, function, and any STI methods invoked.

12.113 12.8.4 Use STI Query for External Data

STI-111 The STI infrastructure shall use the STI Query method to service external system requests for information and to provide telemetry data about an STI application.

Formatted: HTML Preformatted

Formatted: Font: Not Bold

Formatted: Font: 10 pt

Formatted: Interface Heading, Left

Formatted: Font: 10 pt, Not Bold

Formatted: Font: 10 pt

Formatted: Source Text, Font: 10 pt

Formatted: Table List, Space Before: 0 pt, After: 0 pt, Outline numbered + Level: 1 + Numbering Style: Bullet + Aligned at: 0" + Indent at: 0.15"

Formatted: Font: 10 pt

Formatted: Interface Heading, Left

Formatted: Font: 10 pt, Not Bold

Formatted: Font: 10 pt

Formatted: Font: 10 pt

Formatted: Font: 10 pt

Formatted: Font: 10 pt, Not Bold

Formatted: Font: 10 pt

Formatted: Interface Heading, Left

Formatted: Font: 10 pt

Formatted: Font: 10 pt

Formatted: Font: 10 pt

Formatted: Interface Heading, Left

Formatted: Font: 10 pt, Not Bold

Formatted: Heading 3, Indent: Left: 0", First line: 0"

Formatted: Heading 3, Indent: Left: 0", First line: 0"

Formatted: Indent: Left: 0", Hanging: 0.81", Outline numbered + Level: 2 + Numbering Style: 1, 2, 3, ... + Start at: 1 + Alignment: Left + Aligned at: 0" + Indent at: 0"

Formatted: Heading 3, Indent: Left: 0", First line: 0"

Formatted: Heading 3, Indent: Left: 0", First line: 0"

Formatted: Heading 3, Indent: Left: 0", First line: 0"

Formatted: Heading 3, Indent: Left: 0", First line: 0"

Formatted: Default Paragraph Font, Font: 10.5 pt, Font color: Auto, Pattern: Clear

12.9 Clock Control Interface

Clock components must also be STI applications or devices to be able to be accessed by a handle ID.

"Provide a definition" implies supplying a consistent interface, which may be used or inherited by other methods. The implementation of such an interface may be supplied by others. For functions, an abstract method or class, a virtual method, or prototype is usually supplied.

Any apparent discrepancy between clock-provided and infrastructure-provided of the titles and requirements is easily resolved by noting that the infrastructure provides the definition while the clock inherits an implementation or provides the implementation directly.

Clock components must be STI applications or devices or services to be able to be accessed by a handle ID.

12.9.1 STI Infrastructure-Provided CLK_GetTime Method

STI-113 The STI infrastructure shall provide the CLK_GetTime() definition as specified in Table 91, to be implemented by an STI clock.

Table 91: CLK_GetTime() Definition

Declaration	<pre>interface ClockControl { Result CLK_GetTime(out TimeWarp currentTime); };</pre>
Description	Obtain the current value of the clock.
Parameters	<ul style="list-style-type: none"> currentTime: A buffer to store the current time, as an interval since the epoch
Return	On success, return the predefined Result value OK; otherwise, return one of the predefined Result values indicating failure. See 12.4.6 STI Infrastructure-Provided Result Values.
Notes	The output value returned represents a direct measurement of elapsed time since its respective epoch according to the clock's time scale and is not adjusted for nor dependent upon any locale-specific time representations (i.e. time zone, daylight savings time, etc.) or effects of relativity.

12.9.2 STI Infrastructure-Provided CLK_SetTime Method

STI-114 The STI infrastructure shall provide the CLK_SetTime() definition as specified in Table 92, to be implemented by an STI clock.

Table 92: CLK_SetTime() Definition

Declaration	<pre>interface ClockControl { Result CLK_SetTime(in TimeWarp deltaTime); };</pre>
Description	Set the current value of the clock.
Parameters	<ul style="list-style-type: none"> deltaTime: The step size, relative to the current clock value

Commented [HLM(L46)]: [JIRA issue STI_78: Missing Clock Methods](#)

Formatted: Heading 3

Formatted: Font: 10 pt

Formatted: Font: 10 pt

Formatted: Font: 10 pt

Formatted: Font: 10 pt

Formatted: Font: 10 pt

Formatted: Font: 9 pt

Formatted: Font: 10 pt

Formatted Table

Formatted: HTML Preformatted

Formatted: Font: Not Bold

Formatted: Font: 10 pt

Formatted: Space Before: 0 pt, After: 0 pt

Formatted: Font: 10 pt

Formatted: Font: 10 pt

Formatted: Font: 10 pt

Formatted: Font: 10 pt

Formatted: Heading 3

Formatted: Font: 10 pt

Formatted: Font: 10 pt

Formatted: Font: 10 pt

Formatted: Font: 10 pt

Formatted: Font: 10 pt

Formatted: Font: 10 pt

Formatted: Font: 9 pt

Formatted: Font: 10 pt

Formatted Table

Formatted: HTML Preformatted

Formatted: Font: Not Bold

Formatted: Font: 10 pt

Formatted: Space Before: 0 pt, After: 0 pt

Formatted: Font: 10 pt

Formatted: Default Paragraph Font, Font: 10.5 pt, Font color: Auto, Pattern: Clear

Return	On success, return the predefined Result value OK; otherwise, return one of the predefined Result values indicating failure. See 12.4.6 STI Infrastructure-Provided Result Values.
Notes	This function will "step" the base clock. Since the offset is applied against the base clock measurement, it affects all calendar representations of the clock accordingly. It may be used to synchronize a clock based on information obtained after start up. Not all clock components are required to support this operation. If a clock component is read-only and not settable from an application, this function should return UNIMPLEMENTED. Note that this is not intended for implementing the concept of a "time zone" or "local time" (i.e. the time as commonly expressed in a given geopolitical region). If the platform implements the concept of local time, then the specific local time offset or conversion rules should be configured using the Configure and Query methods as described in sections 12.7.11 and 12.7.12. The specific property name and value format for time zone configuration is platform-defined. On some systems, it may be directly configured as a number (i.e. minutes ahead of GMT) or it may be configured as a string reflecting a predefined rule (i.e. "US/Eastern") if the system is capable of automatic daylight savings time adjustments.

Formatted: Font: 10 pt
Formatted: Font: 10 pt

Formatted: Font: 10 pt
Formatted: Font: 10 pt
Formatted: Font: 10 pt
Formatted: Font: 10 pt
Formatted: Hyperlink, Font: 10 pt
Formatted: Font: 10 pt
Formatted: Font: 10 pt
Formatted: Font: 10 pt

12.9.3 STI Infrastructure-Provided CLK_SetTimeAdjust Method

STI-115 The STI infrastructure shall provide the CLK_SetTimeAdjust() definition as specified in Table 93 to be implemented by an STI clock.

Table 93: CLK_SetTimeAdjust() Definition

Declaration	<pre>interface ClockControl { Result CLK_SetTimeAdjust(in TimeRate rateAdjustment); };</pre>
Description	Adjust the tick rate of the clock component.
Parameters	<ul style="list-style-type: none"> rateAdjustment: The amount of adjustment to apply
Return	On success, return the predefined Result value OK; otherwise, return one of the predefined Result values indicating failure. See 12.4.6 STI Infrastructure-Provided Result Values.
Notes	The rateAdjustment parameter is a signed integer, where the value of 0 represents the nominal or free-run rate of the clock without any adjustment applied. If any adjustment had been previously applied, calling this function with a value of 0 will restore a clock to its default rate. A positive value will cause the clock frequency to increase from the nominal rate, and a negative value will cause the clock frequency to decrease from the nominal rate. The specific unit of rate increase/decrease is platform defined, although typically might reflect a number of parts per million or parts per billion depending on clock design. If the underlying device does not support rate adjustment, then this function will return the Predefined UNIMPLEMENTED Result value. A typical use-case of this function would periodically compute the difference between the reference clock and the local clock component, which is then multiplied by a feedback ratio (proportional coefficient) to compute the adjustment value to pass into this function.

Formatted: Heading 3
Formatted: Font: 10 pt
Formatted: Font: 10 pt
Formatted: Font: 10 pt
Formatted: Font: 10 pt
Formatted: Font: 10 pt
Formatted: Font: 10 pt
Formatted: Font: 10 pt
Formatted: Font: 10 pt
Formatted: Font: 9 pt
Formatted: Font: 10 pt
Formatted Table
Formatted: HTML Preformatted
Formatted: Font: Not Bold
Formatted: Font: 10 pt
Formatted: Font: 10 pt
Formatted: Space Before: 0 pt, After: 0 pt
Formatted: Font: 10 pt
Formatted: Font: 10 pt
Formatted: Font: 10 pt
Formatted: Font: 10 pt
Formatted: Font: 10 pt
Formatted: Font: 10 pt
Formatted: Heading 3
Formatted: Font: 10 pt
Formatted: Font: 10 pt

12.9.4 STI Infrastructure-Provided CLK_GetTimeAdjust Method

STI-116 The STI infrastructure shall provide the CLK_GetTimeAdjust() definition as specified in Table 94 to be implemented by an STI clock.

Table 94: CLK_GetTimeAdjust() Definition

Formatted: Font: 10 pt
Formatted: Font: 9 pt
Formatted: Default Paragraph Font, Font: 10.5 pt, Font color: Auto, Pattern: Clear

Description	Delay the caller until the clock reaches the indicated value.
Parameters	<ul style="list-style-type: none"> endTime: The time value at which the function should return, relative to the clock epoch
Return	On success, return the predefined Result value OK; otherwise, return one of the predefined Result values indicating failure. See 12.4.6 STI Infrastructure-Provided Result Values.
Notes	The call may be interrupted under some circumstances, causing the infrastructure to return to the caller before the end time has been reached. In these cases, the infrastructure should return the WARNING response. Note that the actual Sleep time may be longer than requested due to the resolution of the clock component and operating system scheduling variances. Setting a clock using CLK_SetTime() while this operation is in progress has undefined effects on the delay operation.

Formatted: Font: 10 pt

Formatted: Space Before: 0 pt, After: 0 pt

Formatted: Font: 10 pt

Formatted: Font: 10 pt

Formatted: Font: 10 pt

Formatted: Font: 10 pt

Formatted: Font: 10 pt

Formatted: Default Paragraph Font, Font: 10.5 pt, Font color: Auto, Pattern: Clear

Annex A: Language Translations

This appendix describes some specific mappings to programming languages for STI interfaces. This section is intended to clarify certain aspects of the IDL mappings to ensure that different implementations will remain consistent with regard to these interface definitions.

Many of the interface definitions in this specification are provided as OMG Interface Definition Language (IDL) fragments. OMG also specifies a specific method for mapping these interfaces to source code in various common programming languages, and the STI implementation of these interfaces will adhere to these mappings where relevant.

Earlier versions of the OMG IDL specification were specifically designed for defining the interfaces within a CORBA environment. IDL has since been revised as a general-purpose interface definition language and has been released independently from CORBA since version 3.5. While a compliant implementation of STI may utilize a CORBA-like layer to exchange data between modules, there is no requirement for nor assumption of a CORBA environment within STI. As such, the function prototypes or interface definitions based on the IDL fragments in this specification will not directly include any CORBA references.

All IDL fragments in this document shall be interpreted as belonging to an IDL module called “STI”, with interface and identifier names mapped accordingly. To ensure naming consistency across differing OE implementations, a specific header file/module/namespace needs to be implemented such that the same function names are present and available on all STI implementations. Each programming language environment has differences in the paradigms used for this purpose.

The general STI architecture can also be implemented in programming languages using the translations prescribed by the IDL specification. Additional directives on how the IDL translations apply to the STI applications and infrastructure is available in this section. This section is intended to clarify certain aspects of the interface translation for commonly used programming languages, but other language translations beyond what is specified here are also possible. The appendix may be extended in a future revision of this specification to contain additional language mappings.

Nearly all modern high-level programming languages support some notion of “packages” or “modules” to separate functionality into logical entities. Whenever possible, all STI functionality should be encapsulated in a single package or module called “STI”. Note that some languages, such as Java, dictate additional package naming recommendations. Any such language-specific package name recommendations should also be adhered to. In C and C++, the interfaces are available through multiple header files.

All object-oriented languages such as C++, Java, and Python generally support the same fundamental concepts of inheritance and interfaces. For these languages, the interface translation is fairly straightforward, and the application will use the language’s native inheritance mechanisms. For other languages such as C, which are not natively object-oriented, the approach differs slightly, but many of the same concepts can still be employed even if not directly supported by the language. Therefore, a different set of requirements will apply to applications implemented in C versus other object-oriented languages.

All STI applications and devices should encapsulate their state in an object or structure of some type, referred to as the “base object”. Even for “singleton” objects of which there can only be one, STI requires that there is still a base object associated with the instance, even if this object does not contain any extra information.

~~Figure 9~~ ~~Figure 9~~ also shows several different optional interfaces that an application or device may implement, depending on its specific design needs. In object-oriented languages, the set of interfaces is indicated in the object definition, using the language’s inheritance mechanisms. In these languages, a “connection” between the implementation and interface is automatically made through the language’s type system. In non-object-oriented languages, such as C, a separate mechanism is necessary to explicitly create the connection between a given implementation to the interface it implements. For STI, a naming convention is employed to facilitate this connection.

In object-oriented languages, the conversion to an Instance object is achieved by simply inheriting from the proper base class. In non-object-oriented languages, the application developer will implement this conversion, and it is not specified how the conversion takes place. For a singleton object, this can be a simple global. In C, this could be performed using a pointer conversion of some sort. Alternatively, this could be implemented using a lookup table or dictionary.

A.1 C Language Mapping

The C programming language is standardized as ISO/IEC 9899, with a specific revision to the standard identified by a year number suffix (e.g. ISO/IEC 9899:1999). The STI architecture should be implementable in any current or future version of the C programming language.

A.1.1 Naming Conventions

Unlike other languages, the C language does not include the concept of a “namespace” or “module” to avoid identifier name collisions between global-scope symbols in separate libraries or code units. As such, it is common practice to add a prefix to all global identifier names supplied by a library or module as a means of differentiation.

All infrastructure-provided functions, constants, and types defined in this specification shall be denoted with an “STI_” prefix when mapped to identifiers in the C programming language. For example, the “Instance” type is named “STI_Instance”, the “OK” result value constant is named “STI_OK”, the “Write” method is named “STI_Write”, and so forth.

All application-provided implementation written in the C language shall be denoted with a prefix defined by the application. For instance, if an application were named “Example”, the application-provided application control methods may be called “Example_APP_Instantiate”, “Example_APP_Start”, and so forth.

A.1.2 Header Files

The following header files shall be provided by the infrastructure, such that applications can use the #include preprocessor directive to incorporate the respective resources:

Table 2190: C Language Header Files

Include File	Provides
STI.h	C language STI data types and abstract object definitions. This file provides declarations of all data types described in section 40.4.12.4 .
STI_APIs.h	C language function prototype declarations for all infrastructure-provided API calls. This file provides declarations of all calls described in section 40.6.12.7 .
STI_ApplicationControl.h	C language function prototype declarations associated with ApplicationControl interface, as described in sections 40.5.2.12.5 – 12.5.11 .
STI_DeviceControl.h	C language function prototype declarations associated with DeviceControl interface, as described in section 40.5.3.12.6 .
STI_Source.h	C language function prototype declarations associated with the Source interface, as described in section 40.5.4.12.5.12 .
STI_Sink.h	C language function prototype declarations associated with the Sink interface, as described in section 40.5.4.2.12.5.13 .
STI_RandomAccess.h	C language function prototype declarations associated with the RandomAccess interface, as described in sections 40.5.4.3.12.5.14 – 12.5.15 .

After utilizing the language-specific import statement, all components of the STI API can be referenced using the paradigm of the respective language’s package/module facility.

A.1.3 Interface Type Mappings

Table 5, Infrastructure-provided Data Types, in section [40.4.12.4](#) indicates the general semantics of each STI-defined type. These general semantics, in turn, determine the proper method to pass a value or object of that type through an IDL-defined interface or function definition.

Formatted: Default Paragraph Font, Font: 10.5 pt, Font color: Auto, Pattern: Clear

The table below indicates the basic type mappings for the C language. This table also indicates whether an operand should be passed as value or as a pointer/reference, and how the pointer type should be qualified, if applicable. For operations which utilize an abstract base type containing application-defined data of arbitrary size (e.g. Message and PropertyValue types), the size of this data will also be specified. In these cases, a single object in the IDL fragment will translate to two arguments in the C function prototype. This also applies to strings, as the C language implements strings as a pointer to the `char` type, rather than as a distinct value type in itself.

Table 2294: C Language Data Type Mapping

Semantics	Usage	Pass As	C Data Type(s)	Applicable to
Integer, Enumeration, or aggregate value	in, return	Value	STI_<type>	Access, CalendarKind, FileSize, HandleID, Nanoseconds, Offset, QueueMaxMessages, Result, Seconds, TestID, TimeRate, TimeWarpResult, HandleID, TimeWarp, Access, etc.
	out, inout	Pointer to Value	STI_<type> *	
string	in, return	Pointer	const char *	Object Names
	out, inout	Pointer and Size	char *, size_t	
Abstract Object	in	Pointer and Size	const STI_<type> *, size_t	Message, PropertyValue
	out	Pointer and Size	STI_<type> *, size_t	
Base Type	any	Pointer	STI_Instance *	Context Objects

Formatted Table

Commented [HLM(L47): JIRA issue STI 43: Remove "etc." from Tables

A.1.4 Inheritance and Base Types

Although C is not an object-oriented language by nature, the same basic concepts can still be manually implemented by the programmer through use of specific patterns and by utilizing type casting where necessary. The main requirement is that structure definitions be defined appropriately such that a pointer to a base structure can be reliably converted to a derived structure and vice versa.

The first element of a C structure is guaranteed to be at the same memory address as the structure itself, as specified in ISO/IEC 9899 section 6.7.2.1, as follows:

A pointer to a structure object, suitably converted, points to its initial member, and vice versa. There may be unnamed padding within a structure object, but not at its beginning.

Given this requirement, the concept of single inheritance may be implemented simply by ensuring that the “base type” of a given structure is declared as its first element. For STI, the base type of all context objects is the Instance type. The specific content of the Instance type is implementation-defined, but the infrastructure will provide this type such that it is suitable for use as a base type, as in this example:

```
typedef struct
{
    STI_Instance Base;
    int LocalValue;
} Example_Object;
```

Using this definition, a pointer to the base object (STI_Instance*) may be safely typecast by the application to the derived object (Example_Object*) and vice-versa. Note that while this approach generally works for simple cases, more complex applications may necessitate a different approach. The STI infrastructure only stipulates that interaction with the infrastructure takes place using an Instance object; more complex applications may in turn use this object to index into a larger state table or database.

Formatted: Default Paragraph Font, Font: 10.5 pt, Font color: Auto, Pattern: Clear

A.1.5 Interface Operations

All methods defined in the STI application or device control interfaces in section [40.5.12.5 – 12.6, Application and Device Control Interface](#) shall have a context object as the first parameter in the calling sequence.

Formatted: Font: 10 pt

All operations defined in the STI application or device control interfaces in section [40.5.12.5 – 12.6, Application and Device Control Interface](#), require a context object, which is the in-memory data structure comprising the device or application state. This is an application defined structure that may contain any arbitrary state information needed by the application. In object-oriented languages this object is often referred to as the “self” or “this” object and is usually implicitly supplied through the respective language internal mechanisms.

Formatted: Font: 10 pt

Since the C programming language does not provide these object-oriented features, the context object shall be explicitly included as the first argument in the function prototype, followed by the remainder of the operands specified in the interface definition.

STI requires that all such context objects ~~in the system~~ are derivatives of the infrastructure-defined Instance type. Therefore, in the C programming language, all interaction between the infrastructure and the application will use a pointer to the “STI_Instance” type to identify the target of the operation. For example, the C prototype for the APP_Instance() and APP_Start() operations in the “Example” application would be:

```
STI_Instance*   Example_APP_Instance(STI_HandleID id, const char *name);
STI_Result      Example_APP_Start(STI_Instance *inst);
```

A.2 C++ Language Mapping

The C++ programming language is standardized as ISO/IEC 14882, with a specific revision to the standard identified by a year number suffix (e.g. ISO/IEC 14882:2003). The STI architecture should be implementable in any current or future version of the C++ programming language.

Mapping of the STI interfaces to C++ should follow the guidelines set forth in the OMG IDL C++ language mapping. However, in STI there is no assumption or dependence on CORBA types or interfaces. This section is intended to clarify how the C++ language mapping applies to STI.

A.2.1 Naming Conventions

All STI infrastructure-provided functions, constants, and types shall be defined within a C++ namespace called “STI”. For example, the “Instance” type is named “STI::Instance”, the “OK” result value constant is named “STI::OK”, the “Write” method is named “STI::Write”, and so forth.

A.2.2 Header Files

The following header files shall be provided by the infrastructure, such that applications can use the #include preprocessor directive to incorporate the respective resources:

Table 2392: C++ Language Header Files

Include File	Provides
STI.hh	Fundamental STI data types and abstract object definitions. This file provides declarations of all data types described in section 40.4.12.4 .
STI_APIs.hh	Function prototype declarations for all infrastructure-provided API calls. This file provides declarations of all calls described in section 40.6.12.7 .
STI_ApplicationControl.hh	ApplicationControl interface class definition, as described in section 40.5.2.12.5.1 – 12.5.11 .
STI_DeviceControl.hh	DeviceControl interface class definition, as described in section 40.5.3.12.6 .

Formatted: Default Paragraph Font, Font: 10.5 pt, Font color: Auto, Pattern: Clear

Include File	Provides
STI_Source.hh	Source interface class definition, as described in section 10.5.4.12.5.12 .
STI_Sink.hh	Sink interface class definition, as described in section 10.5.4.2.12.5.13 .
STI_RandomAccess.hh	RandomAccess interface class definition, as described in section 10.5.4.3.12.5.14 – 12.5.15 .

After utilizing the language-specific import statement, all components of the STI API can be referenced using the paradigm of the respective language’s package/module facility.

A.2.3 Constructor and Destructor

STI defines the `APP_Instance()` and `APP_Destroy()` methods as a means to construct and destruct instances, rather than relying on language-specific paradigms to invoke a class constructor or destructor. These should be implemented as static methods in the C++ application class. This aligns with a “factory” design pattern that allows additional application control over the construction process. When the infrastructure invokes the factory function, the application should invoke the class constructor appropriately, and return the newly constructed object.

A.2.4 Interface Classes

All other application and device control interfaces defined in section [10.5.12.5 – 12.6, Application and Device Control Interface](#), shall each be mapped to a C++ abstract interface base class provided by the infrastructure.

The class shall declare each of the operations as a pure virtual function, which in turn requires that any derivative class provide an implementation as a prerequisite to being instantiated.

For example, the following class definition would represent the `ControllableComponent` interface:

```
namespace STI
{
    class ControllableComponent
    {
    public:
        virtual Result APP_Start() = 0;
        virtual Result APP_Stop() = 0;
    };
}
```

All application-provided methods shall be class member functions of an application-defined class inheriting from some or all of these abstract interface classes.

Table 5, Infrastructure-provided Data Types, in section [10.4.12.4](#) indicates the general semantics of each STI-defined type. These general semantics, in turn, determine the proper method to pass a value or object of that type through an IDL-defined interface or function definition.

Table 2493: C++ Language Data Type Mapping

Semantics	Usage	Pass As	C++ Data Type(s)	Applicable to
Integer, Enumeration, or aggregate value	in, return	Value	STI::<type>	Access , CalendarKind , FileSize , HandleID , Nanoseconds , Offset

Formatted: Font: 10 pt

Formatted Table

Formatted: Default Paragraph Font, Font: 10.5 pt, Font color: Auto, Pattern: Clear

	out, inout	Pointer to Value	STI::<type> *	QueueMaxMessages, Result, Seconds, TestID, TimeRate, TimeWarpResult, HandleID, TimeWarp, Access, etc.
string (see note)	in, return out, inout	Pointer Pointer and Size	const char * char *, size_t	Object Names
Abstract Object	in out	Pointer and Size Pointer and Size	const STI::<type> *, size_t STI::<type> *, size_t	Message, PropertyValue
Base Type	any	Pointer	STI::Instance *	Context Objects

Commented [HLM(L48): JIRA issue STI 43: Remove "etc." from Tables

The “string” types in C++ shall utilize C-style string representations (pointer to char) rather than the std::string type. This is because the C++ string type typically relies on dynamic memory allocation, and usage of this type may also introduce additional compile-time and run-time dependencies on the C++ standard library. Using C-style strings also facilitates an infrastructure implementation supporting both C and C++.

A.3 Python Mapping

Python is an object-oriented programming language developed by the Python Software Foundation. The language has seen significant adoption by the scientific and research communities and is often used for prototyping software algorithms.

Python is an interpreted language and utilizes a dynamic type system with automatic memory management. As such, it may not be suitable for flight software environments where strict deterministic behavior is required. However, during the SDR development stages, the ability to integrate existing Python applications into an SDR may be highly useful and beneficial. This can be accomplished by mapping the STI interfaces to a Python language environment.

A.3.1 Naming Conventions

All STI infrastructure-provided functions, constants, and types shall be provided through a Python module called “STI”.

All infrastructure-provided types and methods shall be available through this module. For example, the “Instance” type is identified as “STI.Instance”, the “OK” result value constant is named “STI.OK”, the “Write” method is named “STI.Write”, and so forth.

A.3.2 Application Classes

Applications utilizing the STI infrastructure shall use the standard Python module import mechanisms to access the STI infrastructure.

All application base classes utilized with STI shall inherit from the “Instance” class provided through this module.

For example, an application would typically have an “import” statement at the beginning of the source file, followed by an application class definition.

```
import STI

class ExampleWaveform(STI.Instance):
    ...
```

After utilizing the language-specific import statement, all components of the STI API can be referenced using the paradigm of the respective language’s package/module facility. For instance, in languages such as Python, Ruby and

Formatted: Default Paragraph Font, Font: 10.5 pt, Font color: Auto, Pattern: Clear

Lua, the module contents are designated by the module name and a period (.) separator, for example the term “STI.Initialize” would refer to the Initialize function within the STI module.

A.3.3 Constructor and Destructor

The Python application module shall also provide an implementation of the APP_Instance and APP_Destroy methods, implementing a “factory” design pattern that can be invoked by the infrastructure. These are implemented as static methods in the application class.

A.3.4 Interface Operations

Unlike C++, the methods in a Python class are dynamic and do not need to be explicitly declared at compile time. Therefore, applications do not need to inherit from an interface class as in C++. Instead, implementation of any application-provided interface method defined in section [40.5.12.5 or 12.6, Application and Device Control Interface](#), is simply a matter of defining a matching method within the application class.

For example, the following class definition would implement the ControllableComponent interface:

```
class ExampleWaveform(STI.Instance):  
  
    def APP_Start(self):  
        # Implementation-defined action...  
        return STI.OK  
  
    def APP_Stop(self):  
        # Implementation-defined action...  
        return STI.OK
```

All application-provided methods shall be class member functions of an application-defined class inheriting from some or all of these abstract interface classes.

Being a fully object-oriented language with automatic memory management, Python represents all values in software code as a logical object of some type. Unlike C and C++, the actual memory storage and representation of these objects is hidden from the developer, and there is no direct equivalent of a “pointer” type. However, Python does provide some data types that can directly deal with memory reservation and access, and these can be used to exchange data directly with C/C++ software. Since all Python objects are fundamentally self-describing, with a type and size known to the interpreter, the STI interfaces do not need to explicitly indicate size information when passing abstract buffer objects through the interface.

Python classifies certain object types as “immutable”, which include strings, integers, and other fundamental value types. Once instantiated, these values can never be modified; instead, a new, distinct value object will be created, and the previous object can be destroyed. On the other hand, aggregate types such as classes, dictionaries, and lists are “mutable”, meaning that the content can be modified after instantiation. Some fundamental objects have both mutable and immutable variants (e.g. byte/bytarray, frozenset/set, etc.). When translating from IDL, immutable types can only be used to implement “in” or “return” parameter values from an operation definition. Parameters designated as “out” or “inout” will only use mutable types.

Table 5, Infrastructure-provided Data Types, in section [40.4.12.4](#) indicates the general semantics of each STI-defined type. These general semantics, in turn, define the expected mutability of a value of the given type, and therefore its applicability to IDL-defined operations.

Table [2594](#): Python Language Data Type Mapping

Formatted: Font: 10 pt

Formatted: Default Paragraph Font, Font: 10.5 pt, Font color: Auto, Pattern: Clear

Semantics	Mutability	Python Data Type	Applicable to
Integer	immutable	STI.<type>	FileSize, HandleID, Nanoseconds, Offset, QueueMaxMessages, Result, Seconds, TestID, TimeRate, TimeWarpResult, HandleID, etc.
Enumeration	immutable	Integer, see below	Access, CalendarKind
string	immutable	str	Object Names
Aggregate Value	mutable	STI.TimeWarp	TimeWarp
Abstract Object	mutable	Any object type implementing the Python “buffer protocol”, such as bytearray.	Message, PropertyValue
Base Type	mutable	STI.Instance	Context Objects

Commented [HLM(L49): JIRA issue STI 43: Remove "etc." from Tables

Note that Python does not implement enumerated data types as C/C++ do

Access enumerated values shall be implemented as integer constant named values of type Access, with each value being one more than the preceding one.

CalendarKind enumerated values shall be implemented as integer constant named values of type CalendarKind with each value being one more than the preceding one.

A.4 Perl Mapping

Only certain features have been determined to be required when software is implemented in Perl.

The STI module/package namespace for Perl shall be OMG::STI.

An example of its use is:

```
use OMG::STI
```

After utilizing the language-specific import statement, all components of the STI API can be referenced using the paradigm of the respective language’s package/module facility. For instance, in Perl, the module contents are designated by the module name and a double-colon (:) separator, for example the term “OMG::STI::Initialize()” would refer to the Initialize function within the OMG::STI package.

Perl has built-in strings but not enumerations. Enumerations are implemented as a set of constant Integer values. It is possible to implement an enumeration pragma function for this purpose. Perl does not have built-in Integer types. On those platforms without floating point hardware, using a Perl pragma to tell the compiler to use integer operations instead of floating point within the block can make a big difference in performance.

Commented [HLM(L50): JIRA issue STI 11: Update Perl, Ruby, Java, and Lua Sections (Completed in FTF1)

A.5 Ruby Mapping

Only certain features have been determined to be required when software is implemented in Ruby.

The STI module namespace for Ruby shall be STI.

An example of its use is:

```
require 'STI'
```

After utilizing the language-specific import statement, all components of the STI API can be referenced using the paradigm of the respective language’s package/module facility. For instance, in Ruby, the module contents are

Formatted: Default Paragraph Font, Font: 10.5 pt, Font color: Auto, Pattern: Clear

designated by the module name and a period (.) separator, for example the term “STI.Initialize()” would refer to the Initialize function within the STI module.

Ruby has built-in strings but not enumerations. Enumerations are implemented as a set of constant Integer values. These values are not considered to be Enumerable.

A.6 Java Mapping

Only certain features have been determined to be required when software is implemented in Java.

The STI module namespace for Java shall be `org.omg.STI` package.

An example of its use is:

```
import org.omg.STI.*
```

After utilizing the language-specific import statement, all components of the STI API can be referenced using the paradigm of the respective language’s package/module facility. For instance, in Java, the module contents are designated by the package name and a period (.) separator, for example the term “org.omg.STI.Initialize()” would refer to the Initialize function within the STI module.

Java has built-in strings and enumerations.

A.7 Lua Mapping

Only certain features have been determined to be required when software is implemented in Lua.

The STI module namespace for Lua shall be STI.

An example of its use is:

```
STI = require("STI")
```

After utilizing the language-specific import statement, all components of the STI API can be referenced using the paradigm of the respective language’s package/module facility. For instance, in Lua, the module contents are designated by the module name and a period (.) separator, for example the term “STI.Initialize()” would refer to the Initialize function within the STI module.

Lua has built-in strings but not enumerations. Enumerations are implemented as a set of constant Integer values.

Formatted: Default Paragraph Font, Font: 10.5 pt, Font color: Auto, Pattern: Clear