

Date: ~~March-December 2015~~2017

---

**Issue:** SMM12-86 – Show the new SMM logo in the specification.

---



## Structured Metrics Meta-Model (SMM)

Version 1.24

---

OMG Document Number:     ~~ptc/20-175-1203-0307~~

Normative reference:     <http://www.omg.org/spec/SMM/1.24/>

Machine consumable Files: <http://www.omg.org/spec/SMM/>

    Normative:     <http://www.omg.org/spec/SMM/20175110201/SMM.cmf>

---

Field Code Changed

Copyright © 2010, Benchmark Consulting  
Copyright © 2010, eCube Systems, LLC  
Copyright © 2010, Electronic Data Systems  
Copyright © 2010, KDM Analytics  
Copyright © 2010, Object Management Group, Inc.  
Copyright © 2010, Software Revolution  
Copyright © 2010, Tactical Strategy Group

## USE OF SPECIFICATION - TERMS, CONDITIONS & NOTICES

The material in this document details an Object Management Group specification in accordance with the terms, conditions and notices set forth below. This document does not represent a commitment to implement any portion of this specification in any company's products. The information contained in this document is subject to change without notice.

## LICENSES

The companies listed above have granted to the Object Management Group, Inc. (OMG) a nonexclusive, royalty-free, paid up, worldwide license to copy and distribute this document and to modify this document and distribute copies of the modified version. Each of the copyright holders listed above has agreed that no person shall be deemed to have infringed the copyright in the included material of any such copyright holder by reason of having used the specification set forth herein or having conformed any computer software to the specification.

Subject to all of the terms and conditions below, the owners of the copyright in this specification hereby grant you a fully-paid up, non-exclusive, nontransferable, perpetual, worldwide license (without the right to sublicense), to use this specification to create and distribute software and special purpose specifications that are based upon this specification, and to use, copy, and distribute this specification as provided under the Copyright Act; provided that: (1) both the copyright notice identified above and this permission notice appear on any copies of this specification; (2) the use of the specifications is for informational purposes and will not be copied or posted on any network computer or broadcast in any media and will not be otherwise resold or transferred for commercial purposes; and (3) no modifications are made to this specification. This limited permission automatically terminates without notice if you breach any of these terms or conditions. Upon termination, you will destroy immediately any copies of the specifications in your possession or control.

## PATENTS

The attention of adopters is directed to the possibility that compliance with or adoption of OMG specifications may require use of an invention covered by patent rights. OMG shall not be responsible for identifying patents for which a license may be required by any OMG specification, or for conducting legal inquiries into the legal validity or scope of those patents that are brought to its attention. OMG specifications are prospective and advisory only. Prospective users are responsible for protecting themselves against liability for infringement of patents.

## GENERAL USE RESTRICTIONS

Any unauthorized use of this specification may violate copyright laws, trademark laws, and communications regulations and statutes. This document contains information which is protected by copyright. All Rights Reserved. No part of this work covered by copyright herein may be reproduced or used in any form or by any means--graphic, electronic, or mechanical,

including photocopying, recording, taping, or information storage and retrieval systems--without permission of the copyright owner.

#### DISCLAIMER OF WARRANTY

WHILE THIS PUBLICATION IS BELIEVED TO BE ACCURATE, IT IS PROVIDED "AS IS" AND MAY CONTAIN ERRORS OR MISPRINTS. THE OBJECT MANAGEMENT GROUP AND THE COMPANIES LISTED ABOVE MAKE NO WARRANTY OF ANY KIND, EXPRESS OR IMPLIED, WITH REGARD TO THIS PUBLICATION, INCLUDING BUT NOT LIMITED TO ANY WARRANTY OF TITLE OR OWNERSHIP, IMPLIED WARRANTY OF MERCHANTABILITY OR WARRANTY OF FITNESS FOR A PARTICULAR PURPOSE OR USE. IN NO EVENT SHALL THE OBJECT MANAGEMENT GROUP OR ANY OF THE COMPANIES LISTED ABOVE BE LIABLE FOR ERRORS CONTAINED HEREIN OR FOR DIRECT, INDIRECT, INCIDENTAL, SPECIAL, CONSEQUENTIAL, RELIANCE OR COVER DAMAGES, INCLUDING LOSS OF PROFITS, REVENUE, DATA OR USE, INCURRED BY ANY USER OR ANY THIRD PARTY IN CONNECTION WITH THE FURNISHING, PERFORMANCE, OR USE OF THIS MATERIAL, EVEN IF ADVISED OF THE POSSIBILITY OF SUCH DAMAGES.

The entire risk as to the quality and performance of software developed using this specification is borne by you. This disclaimer of warranty constitutes an essential part of the license granted to you to use this specification.

#### RESTRICTED RIGHTS LEGEND

Use, duplication or disclosure by the U.S. Government is subject to the restrictions set forth in subparagraph (c) (1) (ii) of The Rights in Technical Data and Computer Software Clause at DFARS 252.227-7013 or in subparagraph (c)(1) and (2) of the Commercial Computer Software - Restricted Rights clauses at 48 C.F.R. 52.227-19 or as specified in 48 C.F.R. 227-7202-2 of the DoD F.A.R. Supplement and its successors, or as specified in 48 C.F.R. 12.212 of the Federal Acquisition Regulations and its successors, as applicable. The specification copyright owners are as indicated above and may be contacted through the Object Management Group, 140 Kendrick Street, Needham, MA 02494, U.S.A.

#### TRADEMARKS

MDA®, Model Driven Architecture®, UML®, UML Cube logo®, OMG Logo®, CORBA® and XMI® are registered trademarks of the Object Management Group, Inc., and Object Management Group™, OMG™, Unified Modeling Language™, Model Driven Architecture Logo™, Model Driven Architecture Diagram™, CORBA logos™, XMI Logo™, CWM™, CWM Logo™, IIOP™, MOF™, OMG Interface Definition Language (IDL)™, and OMG SysML™ are trademarks of the Object Management Group. All other products or company names mentioned are used for identification purposes only, and may be trademarks of their respective owners.

#### COMPLIANCE

The copyright holders listed above acknowledge that the Object Management Group (acting itself or through its designees) is and shall at all times be the sole entity that may authorize developers, suppliers and sellers of computer software to use certification marks, trademarks or other special designations to indicate compliance with these materials.

Software developed under the terms of this license may claim compliance or conformance with this specification if and only if the software compliance is of a nature fully matching the applicable compliance points as stated in the specification. Software

developed only partially matching the applicable compliance points may claim only that the software was based on this specification, but may not claim compliance or conformance with this specification. In the event that testing suites are implemented or approved by Object Management Group, Inc., software developed using this specification may claim compliance or conformance with the specification only if the software satisfactorily completes the testing suites.

## **OMG's Issue Reporting Procedure**

All OMG specifications are subject to continuous review and improvement. As part of this process we encourage readers to report any ambiguities, inconsistencies, or inaccuracies they may find by completing the Issue Reporting Form listed on the main web page <http://www.omg.org>, under Documents, Report a Bug/Issue (<http://www.omg.org/technology/agreement>.)



# Table of Contents

1	Scope .....	1
2	Conformance .....	2
3	Normative References.....	2
4	Terms and Definitions.....	3
5	Symbols.....	4
6	Additional Information .....	4
6.1	Changes to Adopted OMG Specifications .....	4
6.2	Conventions .....	4
6.3	How to Read this Specification.....	4
6.4	Acknowledgments .....	4
7	SMM Introduction .....	6
7.1	Overview .....	6
7.2	General Usage Notes (Non-normative) .....	7
7.3	Steps in using SMM (Non-normative) .....	7
7.4	Interpreting Measures (Informative) .....	8
8	Core Classes .....	10
8.1	General.....	10
8.2	SmmElement Class (abstract) .....	13
8.3	SmmModel Class .....	13
8.4	SmmRelationship Class (abstract).....	13
8.5	MeasureLibrary Class .....	14
8.6	MeasureCategory Class .....	14
8.7	CategoryRelationship Class .....	15
8.8	TimeStamp Primitive Type .....	16
9	Extensions .....	17

9.1	General.....	17
9.2	Attribute Class.....	17
9.3	Annotation Class .....	18
10	Measures.....	19
10.1	General .....	19
10.2	AbstractMeasureElement Class (abstract).....	22
10.3	Characteristic Class.....	23
10.4	Scope Class.....	23
10.5	Measure Class (abstract) .....	25
10.6	UnitOfMeasure Class .....	28
10.7	Operation Class.....	28
10.8	OCLOperation Class .....	29
10.9	MeasureRelationship Class (abstract).....	29
10.10	EquivalentMeasureRelationship Class.....	30
10.11	RefinementMeasureRelationship Class.....	31
10.12	DimensionalMeasure Class (abstract).....	32
10.13	GradeMeasure Class.....	33
10.14	GradeMeasureRelationship Class .....	34
10.15	Interval Class (abstract).....	34
10.16	GradeInterval Class.....	35
10.17	RankingMeasure Class .....	35
10.18	RankingMeasureRelationship Class .....	36
10.19	RankingInterval Class .....	37
10.20	Influence Data Type (enumeration) .....	37
10.21	ScaleOfMeasurement Data Type (enumeration).....	37
11	Collective Measures.....	39
11.1	General.....	39
11.2	CollectiveMeasure Class.....	41
11.3	Accumulator Data Type (enumeration) .....	42
11.4	BinaryFunctor Data Type (enumeration) .....	43



11.5	DirectMeasure Class.....	43
11.6	CountingMeasure Class.....	43
11.7	BinaryMeasure Class.....	45
11.8	RatioMeasure Class.....	47
11.9	BaseMeasureRelationship Class (abstract).....	48
11.10	ScaledBaseMeasureRelationship Class.....	48
11.11	BaseNMeasureRelationship Class.....	49
11.12	Base1MeasureRelationship Class.....	49
11.13	Base2MeasureRelationship Class.....	49
11.14	CountingUnit Class.....	50
12	Other Measures.....	50
12.1	General.....	50
12.2	NamedMeasure Class.....	52
12.3	RescaledMeasure Class.....	52
12.4	RescaledMeasureRelationship Class.....	53
13	Measurements.....	55
13.1	General.....	55
13.2	Measurement Class (abstract).....	56
13.3	MeasurementRelationship Class (abstract).....	58
13.4	EquivalentMeasurementRelationship Class.....	58
13.5	RefinementMeasurementRelationship Class.....	59
13.6	DimensionalMeasurement Class (abstract).....	59
13.7	GradeMeasurement Class.....	60
13.8	GradeMeasurementRelationship Class.....	62
13.9	RankingMeasurement Class.....	62
13.10	RankingMeasurementRelationship Class.....	63
14	Collective Measurements.....	64
14.1	General.....	64
14.2	CollectiveMeasurement Class.....	65
14.3	DirectMeasurement Class.....	66

14.4	CountingMeasurement Class .....	66
14.5	BinaryMeasurement Class .....	67
14.6	RatioMeasurement Class .....	68
14.7	BaseMeasurementRelationship Class (abstract) .....	68
14.8	ScaledBaseMeasurementRelationship Class .....	68
14.9	BaseNMeasurementRelationship Class .....	68
14.10	Base1MeasurementRelationship Class .....	69
14.11	Base2MeasurementRelationship Class .....	69
15	Named and Rescaled Measurements .....	71
15.1	General .....	71
15.2	NamedMeasurement Class .....	72
15.3	RescaledMeasurement Class .....	73
15.4	RescaledMeasurementRelationship Class .....	74
16	Observations .....	75
16.1	General .....	75
16.2	Observation Class .....	76
16.3	ObservationScope Class .....	77
16.4	ObservedMeasure Class .....	78
16.5	Argument Class .....	79
17	Example Measures (Non-normative) .....	80
17.1	General .....	80
17.2	Common Patterns .....	80
17.3	Business Measures .....	82
17.4	Software Measures .....	88
<del>1</del>	<del>Scope .....</del>	<del>1</del>
<del>2</del>	<del>Conformance .....</del>	<del>2</del>
<del>3</del>	<del>Normative References .....</del>	<del>2</del>
<del>4</del>	<del>Terms and Definitions .....</del>	<del>2</del>
<del>5</del>	<del>Symbols .....</del>	<del>3</del>

<b>6</b>	<b>Additional Information</b>	<b>3</b>
6.1	Changes to Adopted OMG Specifications	3
6.2	Conventions	3
6.3	How to Read this Specification	3
6.4	Acknowledgments	3
<b>7</b>	<b>SMM Introduction</b>	<b>4</b>
7.1	Overview	4
7.2	General Usage Notes (Non normative)	5
7.3	Steps in using SMM (Non normative)	5
7.4	Interpreting Measures (Informative)	5
<b>8</b>	<b>Core Classes</b>	<b>7</b>
8.1	General	7
8.2	SmmElement Class (abstract)	8
8.3	SmmModel Class	9
8.4	SmmRelationship Class (abstract)	9
8.5	MeasureLibrary Class	9
8.6	MeasureCategory Class	10
8.7	CategoryRelationship Class	11
8.8	TimeStamp Primitive Type	12
<b>9</b>	<b>Extensions</b>	<b>13</b>
9.1	General	13
9.2	Attribute Class	13
9.3	Annotation Class	14
<b>10</b>	<b>Measures</b>	<b>14</b>
10.1	General	14
10.2	AbstractMeasureElement Class (abstract)	16
10.3	Characteristic Class	17
10.4	Scope Class	17
10.5	Measure Class (abstract)	19
10.6	UnitOfMeasure Class	21

10.7	Operation Class	21
10.8	OCLOperation Class	22
10.9	MeasureRelationship Class (abstract)	22
10.10	EquivalentMeasureRelationship Class	23
10.11	RefinementMeasureRelationship Class	24
10.12	DimensionalMeasure Class (abstract)	25
10.13	GradeMeasure Class	26
10.14	GradeMeasureRelationship Class	27
10.15	Interval Class (abstract)	27
10.16	GradeInterval Class	27
10.17	RankingMeasure Class	28
10.18	RankingMeasureRelationship Class	28
10.19	RankingInterval Class	29
10.20	Influence Data Type (enumeration)	29
10.21	ScaleOfMeasurement Data Type (enumeration)	29
11	Collective Measures	30
11.1	General	30
11.2	CollectiveMeasure Class	31
11.3	Accumulator Data Type (enumeration)	33
11.4	BinaryFunctor Data Type (enumeration)	33
11.5	DirectMeasure Class	33
11.6	CountingMeasure Class	33
11.7	BinaryMeasure Class	34
11.8	RatioMeasure Class	36
11.9	BaseMeasureRelationship Class (abstract)	37
11.10	BaseNMeasureRelationship Class	37
11.11	Base1MeasureRelationship Class	37
11.12	Base2MeasureRelationship Class	38
12	Other Measures	38
12.1	General	38

12.2	NamedMeasure Class .....	39
12.3	RescaledMeasure Class .....	40
12.4	RescaledMeasureRelationship Class .....	41
13	Measurements .....	41
13.1	General .....	41
13.2	Measurement Class (abstract) .....	42
13.3	MeasurementRelationship Class (abstract) .....	44
13.4	EquivalentMeasurementRelationship Class .....	44
13.5	RefinementMeasurementRelationship Class .....	44
13.6	DimensionalMeasurement Class (abstract) .....	45
13.7	GradeMeasurement Class .....	46
13.8	GradeMeasurementRelationship Class .....	47
13.9	RankingMeasurement Class .....	47
13.10	RankingMeasurementRelationship Class .....	48
14	Collective Measurements .....	49
14.1	General .....	49
14.2	CollectiveMeasurement Class .....	49
14.3	DirectMeasurement Class .....	50
14.4	CountingMeasurement Class .....	50
14.5	BinaryMeasurement Class .....	51
14.6	RatioMeasurement Class .....	52
14.7	BaseMeasurementRelationship Class (abstract) .....	52
14.8	BaseNMeasurementRelationship Class .....	52
14.9	Base1MeasurementRelationship Class .....	53
14.10	Base2MeasurementRelationship Class .....	53
15	Named and Rescaled Measurements .....	53
15.1	General .....	53
15.2	NamedMeasurement Class .....	54
15.3	RescaledMeasurement Class .....	54
15.4	RescaledMeasurementRelationship Class .....	55

16 Observations .....	56
16.1 General .....	56
16.2 Observation Class .....	56
16.3 ObservationScope Class .....	57
16.4 ObservedMeasure Class .....	58
16.5 Argument Class .....	59
17 Example Measures (Non Normative) .....	59
17.1 Common Patterns .....	59
17.2 Business Measures .....	62
17.3 Software Measures .....	64

## Table of Figures

Figure 7.1 - Fundamental Approach .....	9
Figure 8.1 - Core Classes Diagram .....	11
Figure 8.2 - Core Relationship Classes .....	13
Figure 9.1 - SMM Extensions .....	17
Figure 10.1 - Measurable Characteristic and Scope .....	20
Figure 10.2 - Measure Class Diagram .....	22
Figure 11.1 - Collective Measures .....	40
Figure 11.2 - CollectiveMeasurement example .....	41
Figure 11.3 - CountingMeasure Unit of Measure Constraint .....	45
Figure 12.1 - Other Measures .....	52
Figure 13.1 - Measurements .....	56
Figure 13.2 - GradeMeasure Constraint .....	61
Figure 14.1 - Collective Measurements .....	64
Figure 15.1 - Named and Rescaled Measurements .....	72
Figure 16.1 - Observations .....	76
Figure 17.1 - Tracking Measurements across Versions .....	80
Figure 17.2 - Inaccuracy Demonstration .....	81
Figure 17.3 - Uncertainty Demonstration .....	82
Figure 17.4 - Profit Measure .....	82
Figure 17.5 - Customer Satisfaction Measure .....	86
Figure 17.6 - Value Stream Cost Measure .....	87
Figure 17.7 - Cost Measure with Recursion .....	88
Figure 17.8 - Conversion of Information Size to Maintainability .....	89

Figure 17.9 - Conversion of McCabe Cyclomatic to Maintainability.....	89
Figure 17.10 - Conversion of LOC to Maintainability.....	90
Figure 17.11 - Conversion of Comment Count to Maintainability.....	90
Figure 17.12 - SEI Maintainability Demonstration.....	91
Figure 7.1 Fundamental Approach.....	8
Figure 8.1 Core Classes Diagram.....	10
Figure 8.2 Core Relationship Classes.....	12
Figure 9.1 SMM Extensions.....	16
Figure 10.1 Measurable Characteristic and Scope.....	19
Figure 10.2 Measure Class Diagram.....	21
Figure 11.1 Collective Measures.....	37
Figure 11.2 Collective Measurement example.....	37
Figure 11.3 Counting Measure Unit of Measure Constraint.....	40
Figure 12.1 Other Measures.....	47
Figure 13.1 Measurements.....	51
Figure 13.2 Grade Measure Constraint.....	56
Figure 14.1 Collective Measurements.....	60
Figure 15.1 Named and Rescaled Measurements.....	66
Figure 16.1 Observations.....	70
Figure 17.1 Tracking Measurements across Versions.....	74
Figure 17.2 Inaccuracy Demonstration.....	75
Figure 17.3 Uncertainty Demonstration.....	76
Figure 17.4 Profit Measure.....	76
Figure 17.5 Customer Satisfaction Measure.....	77
Figure 17.6 Value Stream Cost Measure.....	78
Figure 17.7 Cost Measure with Recursion.....	78
Figure 17.8 Conversion of Information Size to Maintainability.....	79
Figure 17.9 Conversion of McCabe Cyclomatic to Maintainability.....	80
Figure 17.10 Conversion of LOC to Maintainability.....	80
Figure 17.11 Conversion of Comment Count to Maintainability.....	81
Figure 17.12 SEI Maintainability Demonstration.....	81

## Preface

### OMG

Founded in 1989, the Object Management Group, Inc. (OMG) is an open membership, not-for-profit computer industry standards consortium that produces and maintains computer industry specifications for interoperable, portable, and reusable enterprise applications in distributed, heterogeneous environments. Membership includes Information Technology vendors, end users, government agencies, and academia.

OMG member companies write, adopt, and maintain its specifications following a mature, open process. OMG's specifications implement the Model Driven Architecture® (MDA®), maximizing ROI through a full-lifecycle approach to enterprise integration that covers multiple operating systems, programming languages, middleware and networking infrastructures, and software development environments. OMG's specifications include: UML® (Unified Modeling Language™); CORBA® (Common Object Request Broker Architecture); CWM™ (Common Warehouse Metamodel); and industry-specific standards for dozens of vertical markets.

More information on the OMG is available at <http://www.omg.org/>.

### OMG Specifications

As noted, OMG specifications address middleware, modeling and vertical domain frameworks. A Specifications Catalog is available from the OMG website at:

[http://www.omg.org/technology/documents/spec\\_catalog.htm](http://www.omg.org/technology/documents/spec_catalog.htm)

Specifications within the Catalog are organized by the following categories:

#### Business Modeling Specifications

- Business Rules and Process Management Specifications

#### Language Mappings

- IDL/Language Mapping Specifications
- Other Language Mapping Specifications

#### OMG Middleware Specifications

- CORBA/IIOP
- IDL/Language Mappings
- Specialized CORBA specifications
- CORBA Component Model (CCM)

#### Modeling and Metadata Specifications

- UML
- MOF



- **XMI**
- **CWM**
- **Profile specifications**

#### **Modernization Specifications**

- **KDM**

#### **Platform Specific Model and Interface Specifications**

- **CORBA services**
- **CORBA facilities**

#### **OMG Domain specifications**

#### **OMG Embedded Intelligence specifications**

#### **OMG Security specifications**

All of OMG's formal specifications may be downloaded without charge from our website. (Products implementing OMG specifications are available from individual suppliers.) All specifications are available in PostScript and PDF format and may be obtained from the Specifications Catalog cited above. Certain OMG specifications are also available as ISO standards. Please consult <http://www.iso.org>

#### **OMG Contact Information**

OMG Headquarters  
140 Kendrick Street  
Building A, Suite 300  
Needham, MA 02494  
USA  
Tel: +1-781-444-0404  
Fax: +1-781-444-0320  
Email: [pubs@omg.org](mailto:pubs@omg.org)

### **Typographical Conventions**

The type styles shown below are used in this document to distinguish programming statements from ordinary English. However, these conventions are not used in tables or section headings where no distinction is necessary.

Times/Times New Roman - 10 pt.: Standard body text

**Helvetica/Arial - 10 pt. Bold:** OMG Interface Definition Language (OMG IDL) and syntax elements.

**Courier - 10 pt. Bold:** Programming language elements.

Helvetica/Arial - 10 pt: Exceptions

NOTE: Terms that appear in italics are defined in the glossary. Italic text also represents the name of a document, specification, or other publication.

# 1 Scope

**Issue: SMM12-137 – Scope clause restricts SMM to software measures.**

This specification defines a meta-model for representing measurement information related to any ~~model-~~structured information ~~model-with an initial focus on software, its operation, and its design~~. Referred to as the Structured Metrics Meta-model (SMM), this specification is an extensible meta-model for exchanging both measures and measurement information concerning artifacts contained or expressed by structured models, such as MOF.

The SMM include elements representing the concepts needed to express a wide range of diversified measures. The specification does include a ~~minimal library~~group of ~~software sample~~ measures, but it is not asserting that the listed measures constitute standards themselves; these are supplied simply as non-normative examples.

The SMM is a specification for the definition of measures and the representation of their measurement results. ~~A The measure definitions make up the~~library of measures ~~consists of measure definitions~~ and ~~that~~serves to establish the specification upon which all of the measurements will be based.

The SMM is part of the Architecture Driven Modernization (ADM) roadmap and fulfills the metric needs of the ADM roadmap scenarios as well as other information technology scenarios. ~~SMM's scope, however, is broader than software modelling. This standard looks to fulfill the metric needs across the OMG's wide variety of interest from automotive and business architecture to space and telecommunications.~~

SMM measures describe methods of computing comparable values such as:

~~The SMM specifies the representation of measures without detailing the representation of the entities measured. SMM anticipates that those entities are represented in other OMG meta-models. Measures of software artifacts or their features that are defined within the SMM, the Knowledge Discovery Metamodel (KDM), the Abstract Syntax Tree Metamodel (ASTM), another ADM roadmap meta-model or another OMG meta-model may arise as:~~

- Counts. (~~Votes in an election and L~~lines of code measures exemplify the mechanism.)
- Direct applications of named measurements. (One such named measure is Cyclomatic Complexity.)
- Simple algebraic change of calibration of already defined numeric measures (e.g. the translation ~~to miles from kilometersto 'choice points' from Cyclomatic complexity~~).
- Simple algebraic aggregations of numeric artifact features, including other measures, over sets of ~~software~~artifacts. (Determining an enterprise global sales by summing its regional sales~~the complexity of an application by summing the complexities of the application's elements demonstrates this process~~.)
- Simple range-based grading or classification of already defined numeric measures. (~~Exams are frequently measured on a scale of 0 to 100 which is translated to A, B, C, D and F gradesCyclomatic reliable/unreliable quadrants are one such a grading~~.)
- Qualitative evaluations where the range of evaluations can be mapped to a linear order.

~~The SMM specifies the representation of measures without detailing the representation of the entities measured. SMM anticipates that those entities are represented in other OMG meta-models. Measured artifacts or their features may be defined within Knowledge Discovery Metamodel (KDM), Abstract Syntax Tree Metamodel (ASTM), Value Delivery Modeling Language (VDML), other OMG meta-models, or other structured models.~~

~~Useful metrics must go beyond static (or dynamic) code analysis and technical performance to include factors related to~~

~~information utility and acceptance of the system by the organization(s) participating in an enterprise. To be objective and repeatable, such metrics need to be based on technical characteristics of the system. Given a meta-model representation of such characteristics, the SMM will facilitate the exchange of such measures:~~

The information captured in OMG models often evolves over time. Given ~~the evolutionary nature of system development and~~ the predicate value of metrics with respect to “downstream” problems, metrics are gathered into trends or viewed from historical perspective. As shown in Section Historic and Trend Data, SMM addresses the issues of trend and history to model for system development as long as the historical links of the measured entities are provided.

Consistent with other models defined by OMG, the SMM will be defined using the MOF meta-modeling language. As such, it will have a standard textual representation presented by XMI. Consequently, the exchange of metrics defined by SMM will be in the XMI. These models will, similarly, be compatible with MOF repositories for storage and retrieval by various tools.

## 2 Conformance

---

**Issue: SMM12-122 – Conformance clause restricts SMM to software measures.**

**Issue: SMM12-96 – Define conformance levels for SMM.**

---

~~The principle goal of SMM is the exchange of measurements about software.~~ SMM specifies a meta-model for defining, representing and exchanging measures and measurements of any objects modeled by a MOF-based meta-model. To be SMM compliant, a tool must fully support SMM at ~~one of the two~~ compliance points. An implementation must provide:

- The capability to generate XMI documents based on the SMM XMI schema capturing measurements from the existing model of the tool.
- The capability to import measurements via representations based on the SMM XMI schema and to map the measurements into the existing model of the tool.

---

**Issue: SMM12-96 – Define conformance levels for SMM.**

---

This specification defines two levels of conformance.

- Level 1 requires full implementation of SMM except for the attribute stereotype of Scope [see 10.4].
- Level 2 requires full implementation of SMM including the attribute stereotype of Scope.

Level 1 models measurements where measured elements are identified by name and description or as elements of CMOF classes. Level 2 additionally models measurements where measured elements are identified by name and description, as elements of CMOF classes, or as instances of UML2 stereotypes. Level 2 implementations need to include a UML2 Infrastructure package. Level 1 has no such requirement.

## 3 Normative References

The following normative documents contain provisions, which, through reference in this text, constitute provisions of this specification. For dated references, subsequent amendments to or revisions of any of these publications do not apply.

- UML 2.4.1 Infrastructure Specification
- MOF 2.4.1 Specification
- OCL 2.2 Specification
- XQuery 1.0, XPath 2.0 (W3C Recommendation)
- RFC-2119 (Key words for use in RFCs to Indicate Requirement Levels, S. Bradner, IETF RFC 2119, March 1997 <http://www.ietf.org/rfc/rfc2119.txt>)

## 4 Terms and Definitions

---

**Issue:** SMM12-105 – The wording “base measure(ment)” is ambiguous.

---

We assume the following definitions:

**Base Measure:** A measure which provides input to a derived measure.

**Derived Measure:** A measure not taken directly against a measurand. It is instead derived from values of base measures of the measurand.

**Dimension:** A totally ordered range of values which can be stated as orders of magnitude relative to one another or to an archetypal member.

**Measurand:** An entity quantified by a measurement.

**Measure:** A method assigning comparable numerical or symbolic values to entities in order to characterize an attribute of the entities.

**Measurement:** A numerical or symbolic value assigned to an entity by a measure.

~~**Measurand:** An entity quantified by a measurement.~~

~~**Unit of Measure:** A quantity in terms of which the magnitudes of other quantities within the same total order can be stated.~~

~~**Dimension:** A totally ordered range of values which can be stated as orders of magnitude relative to one another or to an archetypal member.~~

**Measurement Accuracy:** The measurement by which another measurement may be wrong.

**Measurement Range:** The range (set of comparable values) assignable by a given measure.

**Measurement Scope:** The domain (set of entities) to which a given measure may be applied.

~~**Measurement Range:** The range (set of comparable values) assignable by a given measure.~~

---

**Issue:** SMM12-158 – Unit of Measure definition should refer to dimension

---

**Unit of Measure:** A quantity in terms of which the magnitudes of other quantities within the same dimension can be stated.

## 5 Symbols

There are no symbols/abbreviations.

## 6 Additional Information

### 6.1 Changes to Adopted OMG Specifications

There are no changes to other OMG specifications.

### 6.2 Conventions

The keywords “MUST,” “MUST NOT,” “REQUIRED,” “SHALL,” “MUST NOT,” “SHOULD,” “SHOULD NOT,” “RECOMMENDED,” “MAY,” and “OPTIONAL” in this document are to be interpreted as described in RFC-2119.

### 6.3 How to Read this Specification

The rest of this document contains the technical content of this specification.

Although the clauses are organized in a logical manner and can be read sequentially, this reference specification is intended to be read in a non-sequential manner. Consequently, extensive cross-references are provided to facilitate browsing and search.

### 6.4 Acknowledgments

---

#### Issue: SMM12-114 – Add more parties to Acknowledgements

---

The following companies submitted and/or supported parts of this specification:

- Adaptive
- ~~EDS~~
- Benchmark Consulting
- CAST
- eCube Systems
- KDM Analytics
- Micro Focus
- NIST
- Software Revolution
- Tactical Strategy Group

- VDMbee

← NIST

← eCube Systems

The following persons were members of the core team that designed and wrote this specification: ~~Kevin Barnes, Djenana Campara, Larry Hines, Alain Picard, Henk de Man, Pete Rivett, Bill Curtis, Kevin Barnes, Djenana Campara, Nikolai Mansurov, Alain Picard,~~ John Salasin, Michael Smith, and William Ulrich.

## 7 SMM Introduction

**Issue:** SMM12-138 – SMM Introduction Overview clause is too software measures centric.

### 6.57.1 Overview

Measurement is an essential concept to a wide variety of human endeavors such as science, business, finance, sports, politics, economics, education, engineering, cooking and programming. Measurements provide data for ~~disciplined~~ science, engineering, commerce and everyday life. ~~in that~~ Scientists, engineers, business managers and ~~their~~ ~~managers~~ everyone else rely on these comparable evaluations in assessing, controlling, budgeting, synchronizing, and improving the ~~static and operational~~ qualities of systems measured artifacts. Historically, measured artifacts were beer in Babylonian salaries, be stones in Egyptian pyramids, and wheel spacing in Roman chariots. Today, measurements occur in brewing, designing skyscrapers, laying out roads, analyzing software, making medical diagnoses, managing businesses, governing economies and finding bosons.

~~For example, software measurement methods produce comparable evaluations of software or application artifacts. Counts such as number of screens, lines of code and number of methods quantify the size of artifacts along a single dimension. These evaluations readily distinguish larger artifacts from smaller ones; likewise complexity metrics such as Halstead and Cyclomatic separate the simpler artifacts from the more complex. Comparable evaluations form mappings of artifacts of a given type into a single dimension.~~

~~Such is also the case for architecture measures (coupling and cohesion); functional measures (functions defined in system, persistent data as a percentage of all data, functions in current system that map to functions in target architecture); quality measures (failures per unit time, meantime to failure, meantime between repair); performance measures (average batch window clock time, average online response time); software assurance measures; and cost measures.~~

~~Predictive metrics provide a basis for continual system level in contrast to fixed milestone based assessments. These metrics may indicate at some future development stage the probability that the system will or will not meet its requirements.~~

This specification defines a meta-model for representing measurement related to structured model assets and their operational environments referred to as the Structured Metrics Meta-model (SMM).

The SMM promotes a common interchange format that will allow interoperability between existing tools, commercial services providers and their respective models. This common interchange format applies equally well to development and maintenance tools, services and models. SMM complements a common repository structure and so facilitates the exchange of data currently contained within individual tool models that represent modeled assets. Given that the repository's meta-model represents the physical and logical modeled assets at various levels of abstraction as entities and relations, SMM represent the measurements of these assets.

The main goals for the SMM are to provide an extendable meta-model establishing a standard for the interchange of measure libraries and structured model related measurements over the entities modeled by OMG meta-models. By structured model, we mean measurements derived from the structure model artifacts (that is those artifact that are modeled according to the MOF meta-model approach). SMM contains meta-model classes and associations to model measurements, measures and observations. We present and explain diagrams depicting measures, then measurements and finally observations. ~~All initial depictions are in terms of software measurement, but the specification is not limited to representing those modeled elements.~~

SMM supports the meta-models of the OMG by providing for extendable measurements of entities.

SMM supports querying or constraining data of interest by specifying queries which can be expressed either with OCL version 2.2 as published by the OMG, or with XQuery 1.0 as published by the W3C. For XQuery, SMM uses a variant of XPath 2.0 (part of XQuery 1.0) and maps it to XMI using the following rules:



- XPath uses a path expression where each path is a series of steps separated by forward slashes (/).
- The steps are evaluated from left to right, and generally descend the model's tree as they do so
- Each step identifies tree nodes by their classifier name and attributes are specified, just as in XPath with a leading @.

SMM implementations are encouraged to implement OCL and XQuery by providing a wrapper that exposes their models to 3rd party query engines that implement all of the complexities of those languages.

## 6.67.2 General Usage Notes (Non-normative)

The SMM is designed to allow for both the exchange of measurement data, as well as the measures upon which those measurements were established.

Even though there exists a mechanism whereby someone can essentially exchange measurement data without providing any insight into the measures (accomplished with NamedMeasure), this approach is surely not the major thrust of this specification.

The value of SMM comes from the ability of various groups and vendors to be able to define library of measures against different structured models. These libraries can then be exchanged, validated and then used to produce measurements of specific model instances.

In order to exchange measure libraries, the definition of those libraries has to be precise and detailed enough to enable for their unambiguous use in carrying out measurements on models.

While SMM compliance doesn't mandate how to gather measurements from defined measures, it is clear that without any common understanding measures lose most of their value. This section should help to facilitate the understanding of the specification and also provide some background that will help in applying the specification more uniformly.

## 6.77.3 Steps in using SMM (Non-normative)

In general, using the SMM starts with the definition of measures and their libraries. In the case of measures being applied to standard models, these measure libraries could also be pre-defined and made available to various practitioners.

How we proceed next very much depends on the type of environment that the tools are operating in. Tools that are simply using the SMM as a mean of interchanging measurement data will take some measurements, along with the details about the Observation that resulted in those measurements, populate the model and deliver the results.

Other tools that are designed more natively with the SMM in mind will take a bit of a different multi-steps process.

Once we have our measures in place, the next step is to determine what we will be measuring. This is what we call defining the observation. Among other things this will include specifying the model(s) to use (ObservationScope) for taking the measures, as well as determining which measures we are interested in performing (requestedMeasures). It can also include determining and passing in any arguments that might be needed by our requestMeasure(s) and their descendants.

Next step is to apply the requested measure(s) on the model(s) in scope and to figure out the measurements. Once that is done, the resulting model is ready to be used or exchanged.

The step of applying the measure, the "measurement step" is clearly one that can take on many forms depending on the implementer. But regardless of how the process is carried out, the measure library should provide sufficient information for a tool vendor to implement "executable measuring". This "executable measuring" should enable another tool vendor, presented with the same measure libraries, observation information and instance models, to be able to apply those

measures in an unambiguous fashion and to come up with the same measurements (subject to uncertainty errors).

## 6.87.4 Interpreting Measures (Informative)

Measures essentially fall into 2 “categories”, there are direct measures, which are measures that are taken directly against a measurand, and all others, which we shall call derived measures, as their result is based on some other measure(s), direct or derived. Ultimately, every measure comes from a direct measure (otherwise it might end up triggering a defaultQuery for its value).

In order to support many types of measure refinement, where you have a drill-down of measures representing the collective aggregation of values in a top-down fashion, and also in order to make sure that derived measures are correctly linked to their base measure(s), the establishment of a measurement graph shall be considered to essentially be a top-down operation.

In contrast, the taking of measurements to realize such a measurement graph, is normally a bottom-up operation, where the direct measures are first calculated, in order for the various next levels of derived measures to have all of the base measures calculated prior to being calculated themselves.

**Issue: SMM12-92 – Inconsistent handling of inherited attributes.**

**Issue: SMM12-95 – Replace SMM “string” with UML/MOF “String”.**

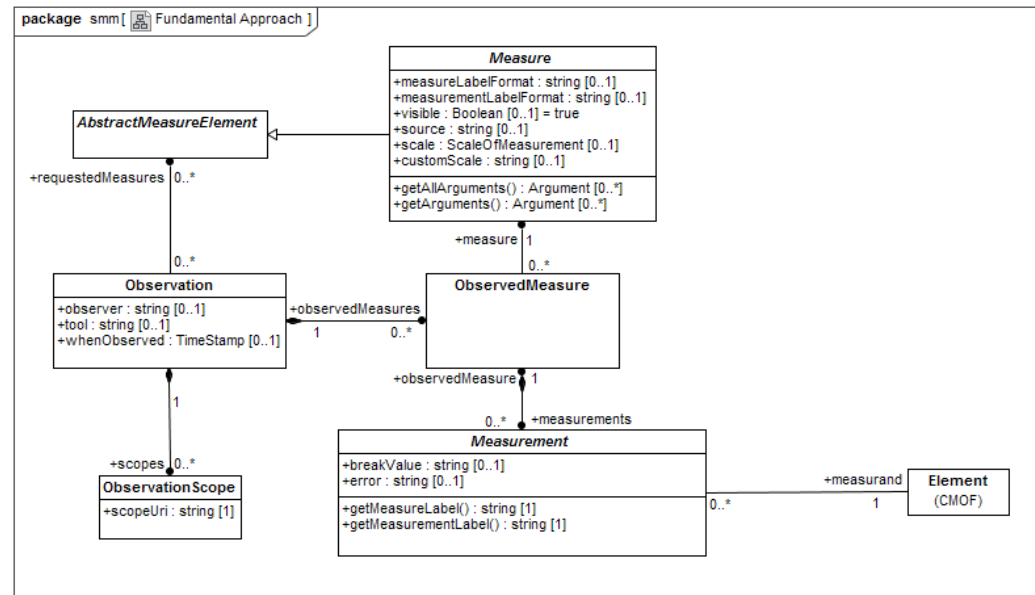

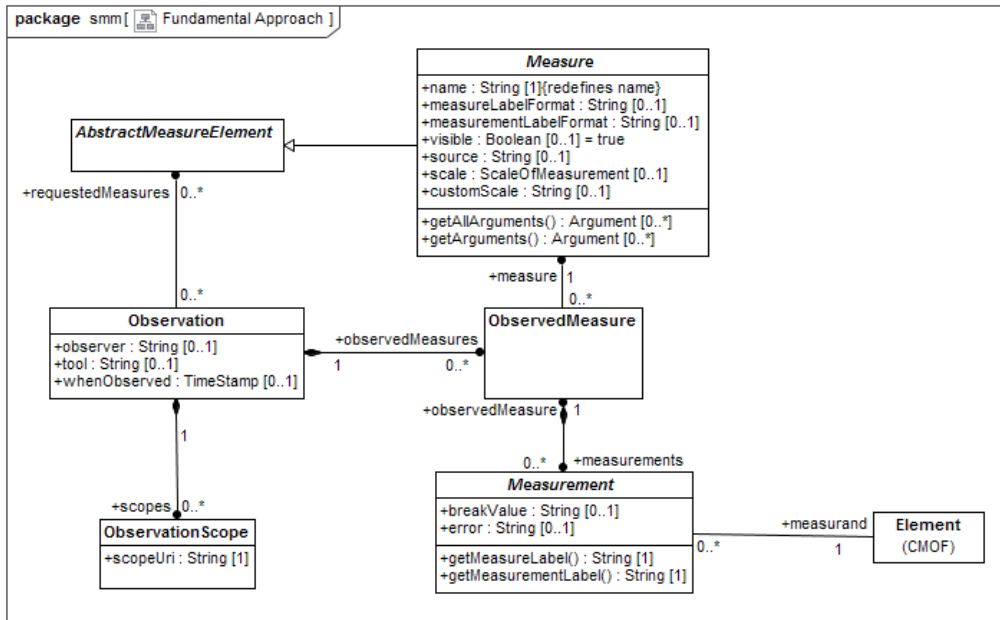

**Figure 7.1 - Fundamental Approach**

SMM avoids duplicating features of the measured artifact as features of the measurement. Consider as an example a log of bug reports. Possible measures are total bug count in the log, total time logged in the log and bugs per time-period. The units of measures are a bug, a unit of time and bugs per time interval, respectively. SMM does not provide representations for bug, start time and end time. Their representations must be provided elsewhere<sup>1</sup>.

A measurement result is precisely identified only if its measure is identified. To understand the meaning of 1000 lines we need to know that it is the result of measuring a program's length in lines. The measured entity must be identified. That is, 1000 lines is for a particular program. Contextual information may also be needed. For example, function point counts of a program may vary depending upon the expert applying the measure.

Figure 7.1 presents the fundamental approach of this specification. Measurement has a value conveying the measurement results. The measurement may be of any MOF element as related by the measurand association. In this way, measurement is applicable to elements of any OMG meta-models including the Knowledge Discovery Meta-model and the Abstract Syntax Tree Meta-model. The measured entity may represent any software artifact or an aspect of an artifact.

The SMM associates an evaluation process, a measure, to each of the measurement. Measures signify functions from the domain of the modeled artifacts and aspects thereof to sets of ordered values.

Contextual information is related by Observation, such as who, where and when. Observation may serve to distinguish distinct utilizations of a given measure on a given measurand.

<sup>1</sup> For example, the General Ledger Specification v1.0 provides representations for start\_date and end\_date.

# 78 Core Classes

## 7.18.1 General

**Issue: SMM12-92 – Inconsistent handling of inherited attributes.**

**Issue: SMM12-95 – Replace SMM “string” with UML/MOF “String”.**

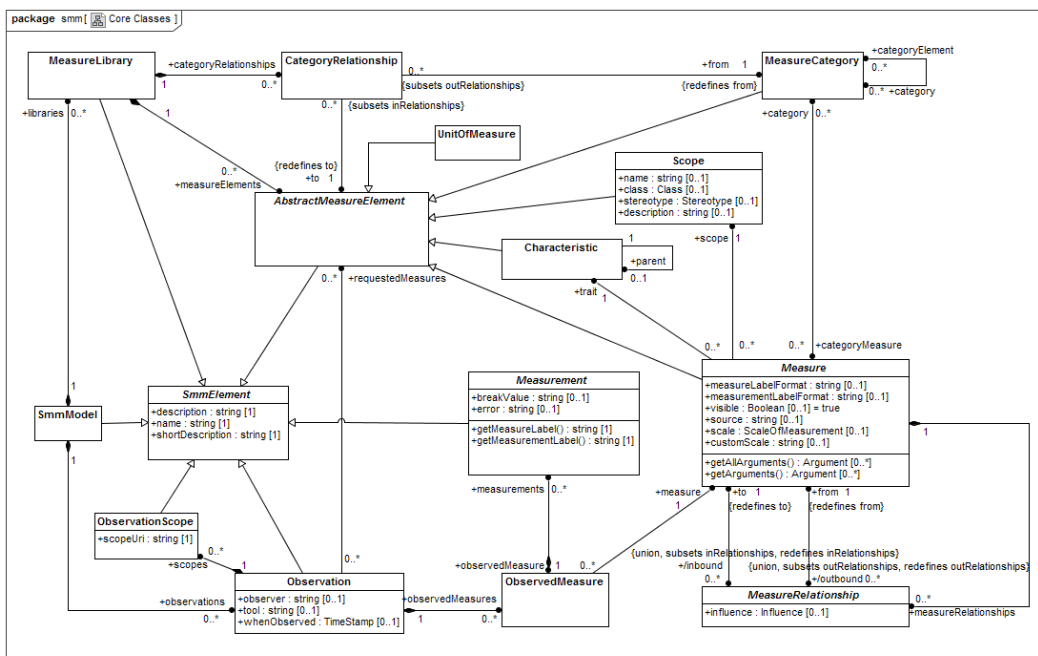



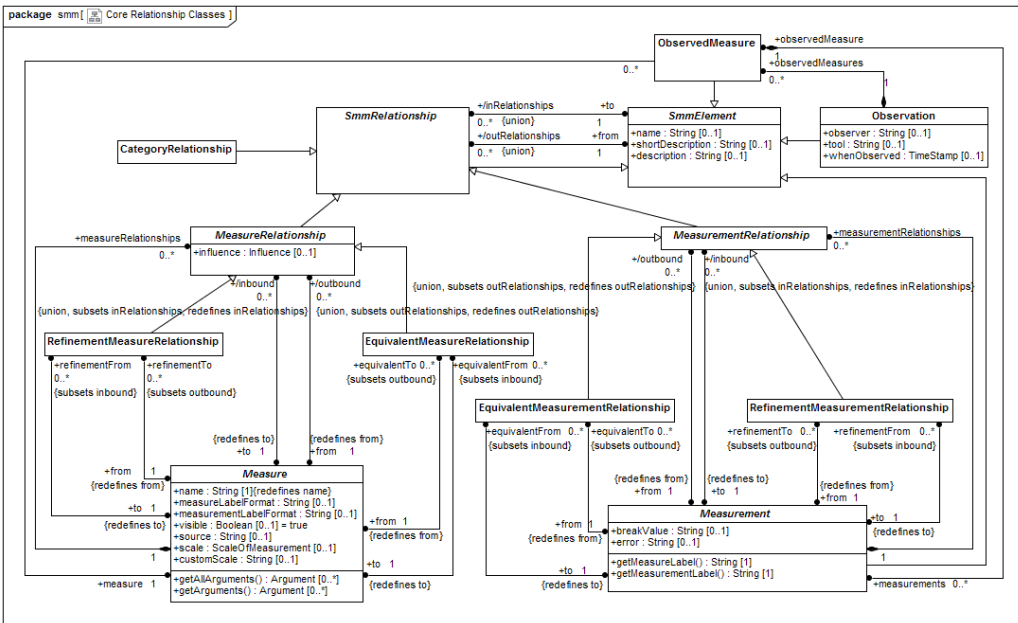
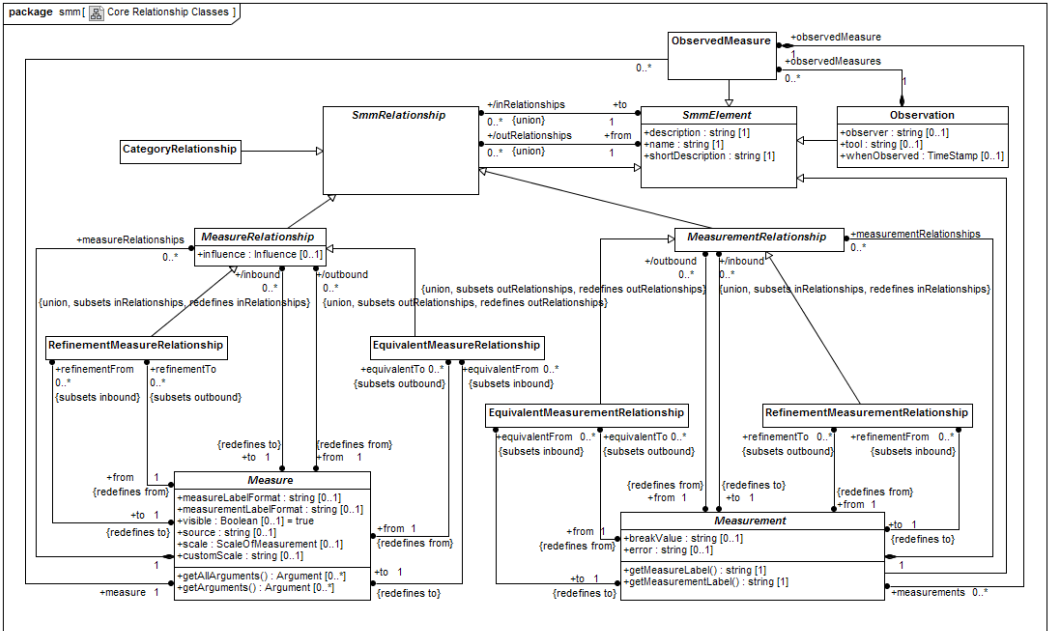

Figure 8.2 - Core Relationship Classes

### 7.28.2 SmmElement Class (abstract)

An SmmElement constitutes an atomic constituent of a model. In the meta-model, SmmElement is the top class in the hierarchy. SmmElement is an abstract class.

---

**Issue:** SMM12-95 – Replace SMM “string” with UML/MOF “String”.

---

#### Attributes

name: <del>string</del> -String [0..1]	Specifies the name of the SMM element (optional)
shortDescription: <del>string</del> -String [0..1]	A short description for the element (optional).
description: <del>string</del> -String [0..1]	A detailed description for the element (optional).

#### Associations

/inRelationships:SmmRelationship [0..*]	The set of relationships such that the current SmmElement is the to-endpoint of these relations. This property is a derived union.
/outRelationships:SmmRelationship [0..*]	The set of relationships such that the current SmmElement is the from-endpoint of these relations. This property is a derived union.

### 7.38.3 SmmModel Class

This class represents the entry point into the SMM model and provides the top-level container for all the elements of the SMM.

#### SuperClass

SmmElement

#### Associations

libraries:MeasureLibrary [0..*]	The set of all MeasureLibrary owned by the model.
observations:Observation [0..*]	The set of all Observation owned by the model.

### 7.48.4 SmmRelationship Class (abstract)

This class is a model element that represents semantic association between SMM elements.

#### SuperClass

SmmElement

## Associations

from:SmmElement [1]	The <i>origin</i> element (also referred to as the from-endpoint of the relationship).
to:SmmElement [1]	The <i>target</i> element (also referred to as the to-endpoint of the relationship).

## 7.58.5 MeasureLibrary Class

This class represents libraries of measures. A library represents the top container for all measure artifacts. The library of measures defines a reference set of measures that can be applied over and over in a way that is independent and decoupled from the models under observation. Therefore it shall be possible to pre-define library of metrics and to pass those libraries to a builder so that the metrics can be applied to specified models, without affecting the measures in the library.

## SuperClass

SmmElement

## Associations

measureElements:AbstractMeasureElement [0..*]	The set of all AbstractMeasureElement owned by the measure library.
categoryRelationships:CategoryRelationship [0..*]	The set of all CategoryRelationship owned by the measure library.

## Semantics

Measure elements can be related across libraries and need not be restricted to their own library.

## 7.68.6 MeasureCategory Class

This class represents categories of measures. A category has measures and other categories as its elements.

A category represents the measures directly associated with an 'element' and the measures of each sub-category likewise associated with an 'element'.

A measure may appear in multiple categories. A category can be a subcategory of other categories indicating only that its measures also are measures of these other categories.

This class may be used to represent a family of similar measures which apply to different scopes such as lines of code in a file, lines of code in a method and lines of code in program. It may also represent a category of measures which are associated with a given field or engineering task. For instance we speak often of Quality Assurance Metrics and Software Maintainability Metrics. The category of a metric may indicate the kind of purpose for which the metric is used.



- Environmental Metrics (e.g., number of screens, programs, lines of code, etc.)
- Data Definition Metrics (e.g., number of data groups, overlapping data groups, unused data elements, etc.)
- Program Process Metrics (e.g., Halstead, McCabe, etc.)
- Architecture Metrics (e.g., average call nesting level, deepest call nesting level, etc.)
- Functional Metrics (e.g., functions defined in system, business data as a percentage of all data, functions in current system that map to functions in target architecture, etc.)
- Quality Metrics (e.g., failures per day, meantime to failure, meantime to repair, etc.)
- Performance Metrics (e.g. average batch window clock time, average online response time, etc.)
- Software Assurance Metrics

Metric categorization has other uses as well. For example, measures may be categorized by tool support.

## SuperClass

AbstractMeasureElement

## Associations

category:MeasureCategory [0..*]	Represents the parent endpoint of the category hierarchy relationship.
categoryElement:MeasureCategory [0..*]	Represents the children endpoint of the category hierarchy relationship.
categoryMeasure:Measure [0..*]	Represents that measure is in this category.

### 7.78.7 CategoryRelationship Class

This class is a model element that represents semantic or named association between Measure categories and other Measure elements. For example, a modeler may choose to create a “gold standard” measure for a selected category. To do so, the modeler can use a category relationship named “gold standard” to associate the measure to the category. See Figure 17.2.

## SuperClass

SmmRelationship

## Associations

from:MeasureCategory [1]	Indicates the measure category which has relation. This property redefines the from-endpoint of SmmRelationship.
to:AbstractMeasureElement [1]	Indicates the Category or Measure element related to the category. A constraint is used to limit the type of SmmElement that can be used. This property redefines the to-endpoint of SmmRelationship.

## Constraints

```
context CategoryRelationship inv:  
to.oclIsTypeOf(MeasureCategory) or  
to.oclIsTypeOf(Measure)
```

## Semantics

CategoryRelationship represents a named association between a measure category and a measure element (AbstractMeasureElement) such as a measure.

### 7.88.8 TimeStamp Primitive Type

This primitive type represents a point in time: for example, a combination of a date and a time within the day. For XMI it is mapped to the XML dateTime type.

# 89 Extensions

## 8.19.1 General

The SMM model provides for a set of simple extension mechanisms that provide a uniform meta-model pattern for extending the SMM model.

**Issue: SMM12-95 – Replace SMM “string” with UML/MOF “String”.**

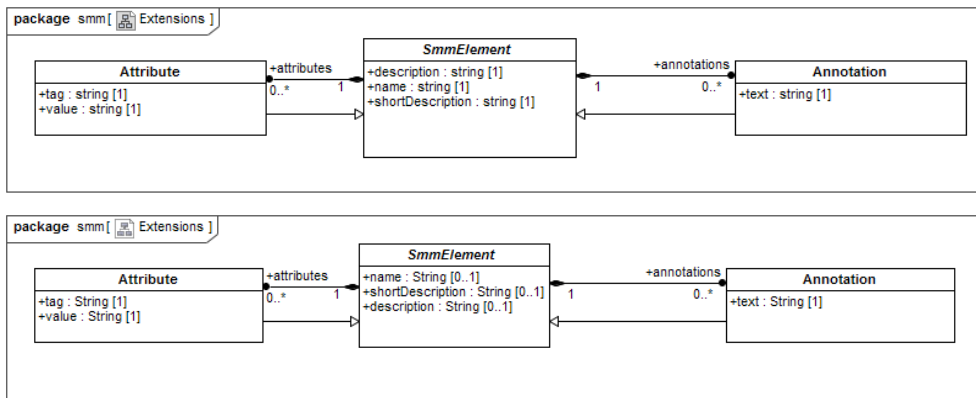

**Figure 9.1 - SMM Extensions**

This diagram defines meta-model elements that allow ad hoc user-defined attributes and annotations to instances of SMM elements. The mechanism of ad hoc user-defined attributes provides a capability to add pairs of <tag, value> to an individual element instance. An ad hoc user-defined attribute is owned by an individual element instance. This means that different instances of the same meta-model element may own completely different user-defined attributes (and some may have none at all).

An Annotation is an ad hoc note owned by an individual element instance. Annotations and attributes are applied to the elements of SMM instances. They may be used by implementer to add specific information to an individual element. They may also be used by an analyst, annotating a given SMM instance.

## 8.29.2 Attribute Class

An attribute allows information to be attached to any model element in the form of a “tagged value” pair (i.e., name=value). Attribute add information to the instances of model elements.

### SuperClass

SmmElement

**Issue: SMM12-95 – Replace SMM “string” with UML/MOF “String”.**

### Attributes

tag: <del>string</del> String	Contains the name of the attribute. This name determines the semantics
-------------------------------	--

	that are applicable to the contents of the value attribute.
value: <del>string</del> String	Contains the current value of the attribute

## Constraints

Attribute MUST NOT have annotations or attributes.

## Semantics

The interpretation of attribute semantics is outside the scope of SMM. It must be determined by the user or the implementer conventions. It is expected that some tools will provide capability to add arbitrary attributes to the instances of the model to supply information needed for their operations beyond the basic semantics of SMM. Such information could support analysis of SMM models by analysis, etc.

An attribute element is not related to a particular meta-model element. It does not define a “virtual” attribute to an extended meta-model element that is instantiated with every instantiation of the new element. Instead, an attribute element can be added to any SMM element. It defines a property of a particular instance, not a property of a class of instances.

### 8.39.3 Annotation Class

Annotations allow textual descriptions to be attached to any instance of a model element.

#### SuperClass

SmmElement

---

**Issue:** SMM12-95 – Replace SMM “string” with UML/MOF “String”.

---

#### Attributes

text: <del>string</del> String	Contains the text of the annotation to the target model element.
--------------------------------	--

## Constraints

Annotations MUST NOT have annotations or attributes.

## Semantics

Annotation allows associating a human-readable text with an instance of any Element.

# 910 Measures

## 9.110.1 General

Measures are evaluation processes that assign comparable numeric or symbolic values to entities in order to characterize selected qualities or traits of the entities. Counting the lines of program code in a software application is one such evaluation.

There may be many measures which characterize a trait with differing dimensions, resolutions, accuracy, and so forth. Moreover, trait or characteristic may be generalized or specialized. For example, line length is a specialization of length which is a specialization of size.

**Issue: SMM12-80 – Threshold values for dimensional measures.**

Each measure has a scope, the set of entities to which it is applicable; a range, the set of possible measurement results; and the measurable property or trait which the measure characterizes. For example, the aforementioned line counting has software applications as one of its scope with line length as one of its measurable trait. Explicitly representing the scope and the measurable trait allows for the consideration of different measures which characterize the same attribute for the same set of entities. Each measurable trait may have multiple, identifiably distinct measures.

**Issue: SMM12-92 – Inconsistent handling of inherited attributes.**

**Issue: SMM12-93 – Some classes are shown in some diagrams without purpose.**

**Issue: SMM12-95 – Replace SMM “string” with UML/MOF “String”.**

**Issue: SMM12-115 – Measure to Scope association missing from Measurable Characteristic and Scope diagram**

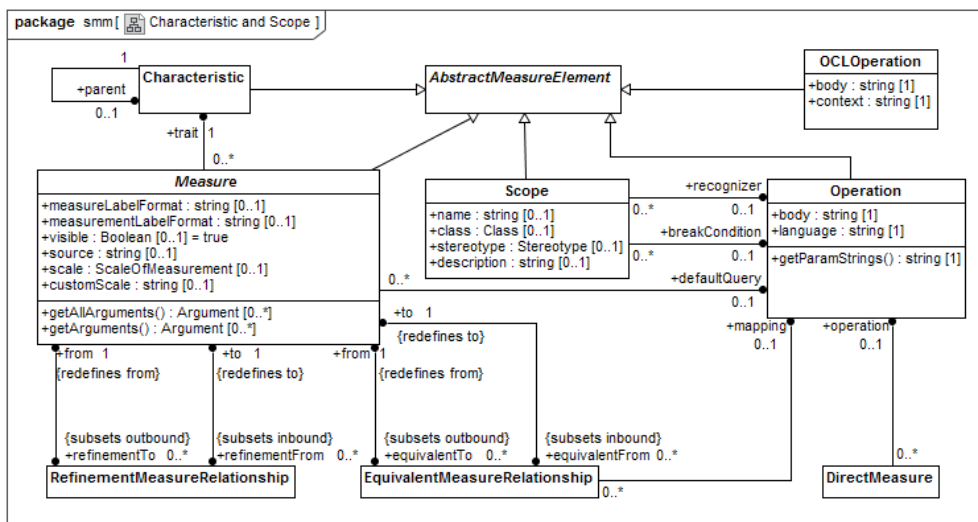

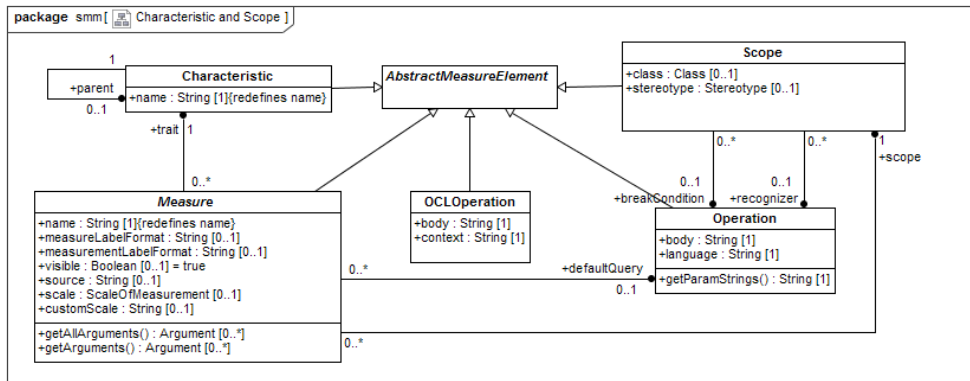

**Figure 10.1 - Measurable Characteristic and Scope**

The evaluation process may assign numeric values which can be ordered by magnitude relative to one another. These measures are modeled by the DimensionalMeasure class.

The evaluation process may alternatively assign numeric values which are percentages or, more generically, ratios of two base measurements. These measures are modeled by the RatioMeasure class. The percentage of comment lines in an application exemplifies this type of measure.

The evaluation process may also assign symbolic values demonstrating a grading which preserve the ordering of underlying base measures. These measures are modeled by the GradeMeasure class. Cyclomatic reliable/unreliable criterion illustrates one such grading. Reliable is comparably better than unreliable. Comparability is essential here because grading is not intended to model every possible assignment of measurands.

The documentations of measures, accomplished with measure libraries, should stand by themselves so that an interchange of measurements may simply reference such documentation and not duplicate it. The documentation of measures should also be precise and complete enough to provide for an unambiguous specification that can be executed on a referenced model, with the exception of the NamedMeasure when used for simple result interchange. The actual ability to execute a model is not part of the compliance to this specification and neither is the method to provide execution defined within this specification. These are left to the implementers.

**Issue:** SMM12-87 – Relax constraint requiring both boundary points of an Interval.

**Issue:** SMM12-92 – Inconsistent handling of inherited attributes.

**Issue:** SMM12-95 – Replace SMM “string” with UML/MOF “String”.

**Issue:** SMM12-105 – The wording “base measure(ment)” is ambiguous.

**Issue:** SMM12-167 – GradeFrom association wrongly named in Figure 10.2

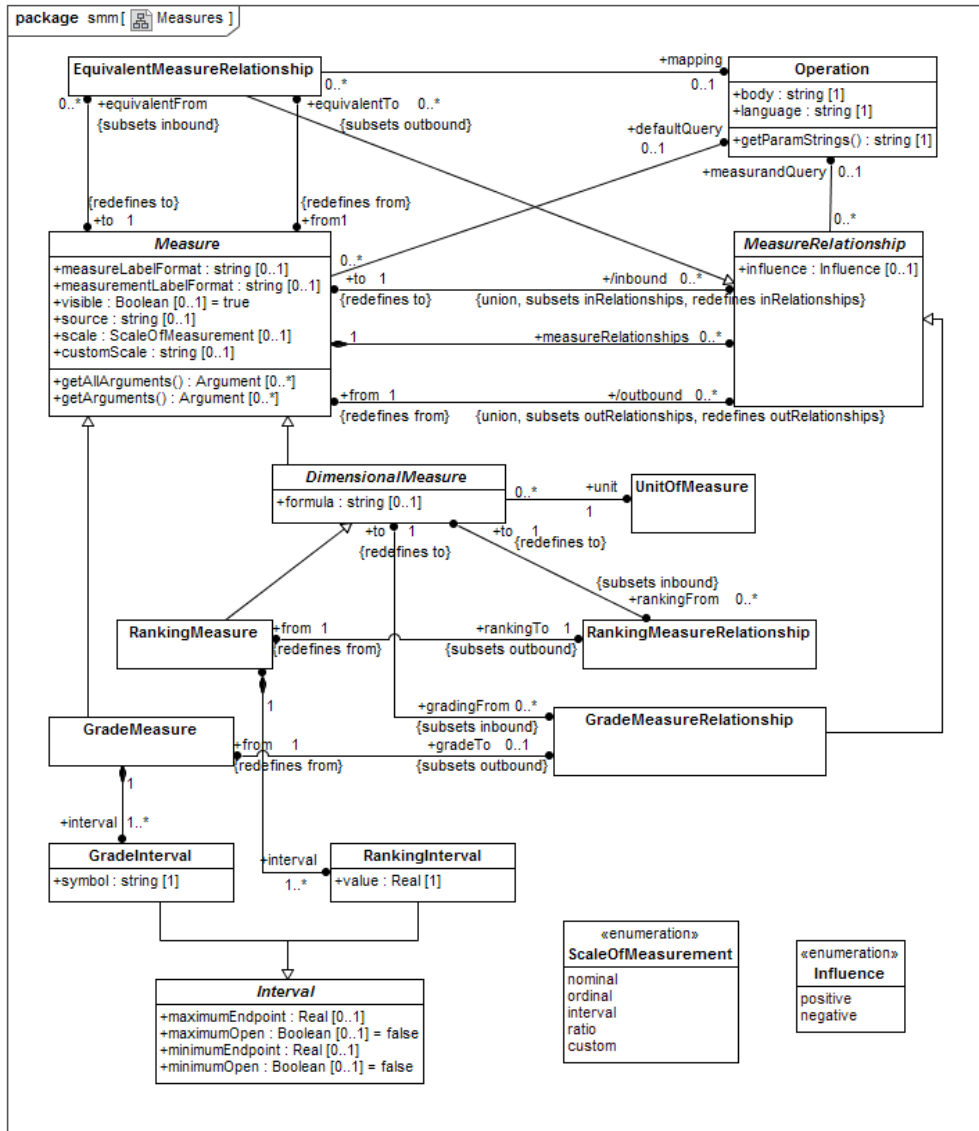

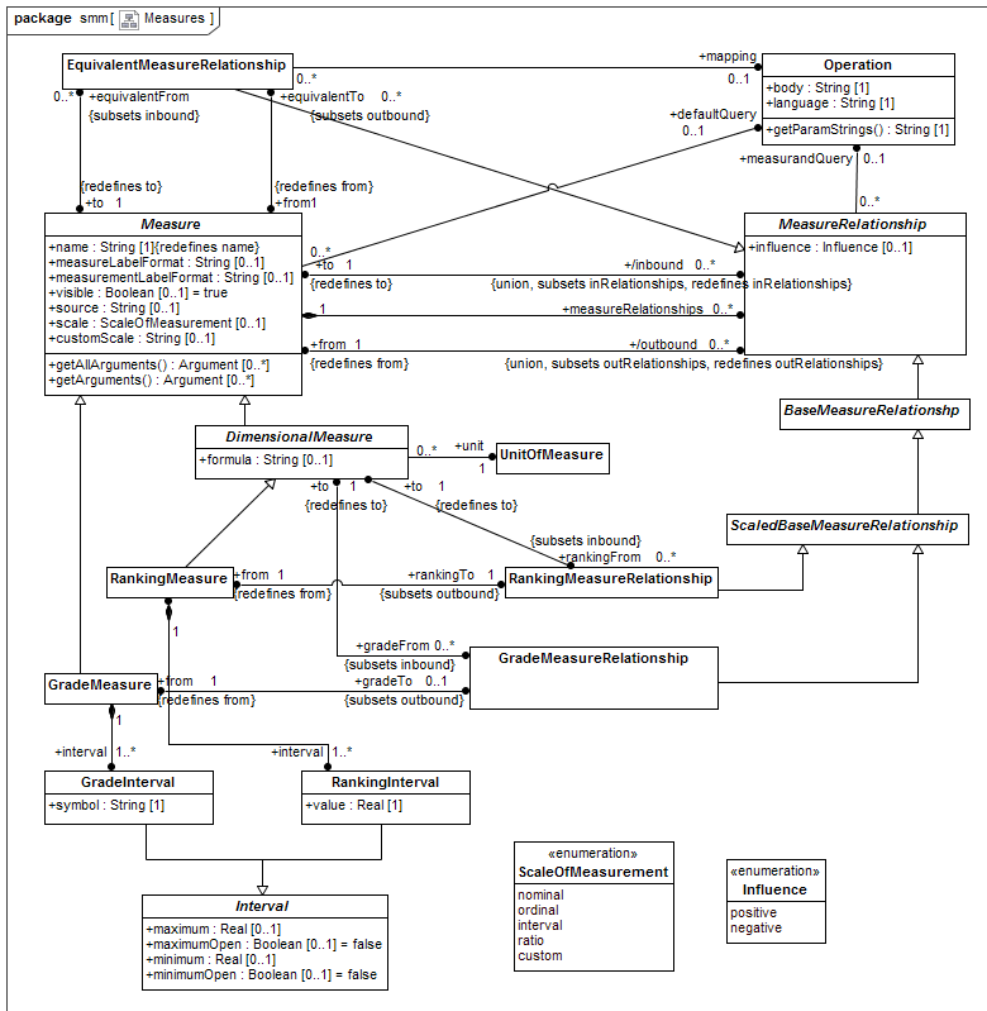

Figure 10.2 - Measure Class Diagram

## 9.210.2 AbstractMeasureElement Class (abstract)

The AbstractMeasureElement is the abstract parent class for all measure entities.

### SuperClass

SmmElement

### Associations

None.



### 9.310.3 Characteristic Class

This class represents a property or trait of the members in its scope, a set of MOF Elements, which may be characterized by applying a measure to those members. By specifying a characteristic a modeler is indicating what aspect, trait or property the measure purports to measure.

Note that Characteristic provides for a representation of a hierarchy of measures based upon the abstraction of measured trait. For example, a length characteristic may be the parent of the fileLength and programLength characteristics. programLength could be the parent of programLinesOfCodeLength.

#### SuperClass

AbstractMeasureElement

---

**Issue:** SMM12-95 – Replace SMM “string” with UML/MOF “String”.

---

**Issue:** SMM12-92 – Inconsistent handling of inherited attributes.

---

#### Attributes

name: <del>string</del> String [1]	Specifies the name of the <del>characteristicSMM element (inherited)</del> . This property redefines the name of SmmElement.
------------------------------------	--

#### Associations

parent:Characteristic [0..1]	Specifies the generalization of this characterization.
------------------------------	--

---

**Issue:** SMM12-146 – General text for Scope class (10.4) assumes class attribute is given.

---

### 9.410.4 Scope Class

This class represents sets of MOF::Elements as domains for measures. The domain is a subset of

- ~~a subset~~ instances of ~~the~~ class specified by the class attribute,
- instances of the stereotype specified by the stereotype attribute, or
- the objects named by the name attribute and described by the description attribute when neither the class nor the stereotype is specified.

If the subset does not include all instances of the given class then a restriction is specified by specifying a recognizer for the subset elements.

The scope of a measure identifies a set of objects as the domain of the measure. The objects all exhibit to varying degrees the trait or property characterized by a measurement. SMM requires that the objects be ~~instances~~ instances of ~~of a single class~~ its domain which. ~~The set of objects~~ may be further restricted by a recognizer operation. The recognizer is optional.

The recognizer, if given, is a boolean operation applicable to instances of the named class. The measure’s scope is restricted to those instances for which the recognizer returns true.

The class or stereotype attributes and recognizer association provide for the formal specification of a measure’s scope. Alternatively, a scope may be informally specified by a name and a description. An informal scope ~~may be preferable in the early stages of development, especially may be required when no~~ before a MOF model for the domain is available ~~or may be preferable in the early stages of development~~. An informal scope may likewise be used when the measure designer understands the semantics of the domain, but does not know the MOF model.

Example: Area of a square where we don't have a class named square.

Binary Measure:

Functor: Times

Base Measure1: Side1 Length

Base Measure2: Side2 Length

Scope:

Name: Square

Description: 2 dimensional closed object with 4 equal length sides.

For the measure above, the characteristic trait is likely to be "area" which could be a child characteristic of the more general "size".

## SuperClass

AbstractMeasureElement

---

**Issue: SMM12-92 – Inconsistent handling of inherited attributes.**

---

## Attributes

class: MOF::Class [0..1]	Specifies the class for elements of the set. See Semantics for format rules.
stereotype: UML::Stereotype [0..1]	Specifies the stereotype for elements of the set. See Semantics.
<del>name: string [0..1]</del>	<del>Specifies a name for the scope (inherited).</del>
<del>description: string [0..1]</del>	<del>Specifies a description of the scope (inherited).</del>

## Associations

recognizer: Operation [0..1]	If given, provides a boolean operation applicable to instances of the class which returns true if and only if the instance is an element of the set.
breakCondition: Operation [0..1]	If given, provides for an operation that returns a string describing a break condition to allow for dynamically grouping instances of the class in scope by a certain value. For example, this can be used to group elements by language name in KDM SourceItem or by folder name in Inventory Items, without having to know all of the possible conditions in advance.

## Constraints

```
context Scope inv:  
(class->isEmpty and stereotype->isEmpty  
 implies (!name->isEmpty and !description->isEmpty))  
and ((name->isEmpty or description->isEmpty)  
 implies !class->isEmpty or !stereotype->isEmpty)
```

## Semantics

The scope is formally specified by the class or stereotype attributes or is informally specified by name and description attributes. The class attribute may name a class within any MOF model. The entities associated as elements of a Scope are restricted to members of the specified class. The stereotype attribute can be used, instead of the class attribute, to indicate that the scope is the members of the classes extended by the stereotype.

The breakCondition attribute is defined as an OCL operation that evaluates to a string representing the group or break value of the class instance.

- Examples:
  1. this.language
    1. This would represent a break on the attribute language, as seen in the KDM inventory model SourceFile class. Applicable as long as the measurand class is the same as the scope class, SourceFile in this example.

### 9.510.5 Measure Class (abstract)

The Measure class (see Figure 7.1) models the specification of measures either by name, by representing derivations of base measures, or by representing method operations directly applied to the measured object. The essential requirement for the measure class is that it meaningfully identifies the measure applied to produce a given measurement. For example, McCabe's cyclomatic complexity could be specified by its name, McCabe's cyclomatic complexity, by a direct measurement operation or by rescaling counts of either independent paths or choice points. A measure may alternatively be identified by citing a library of measure which includes the measure by name.

The scope of a measure identifies a set of objects as the domain of the measure. The objects all exhibit to varying degrees the trait or property characterized by a measurement. SMM requires that the objects be instances of a single class. The set of objects may be further restricted by a recognizer function. The recognizer is optional.

Scope need not be specified if the library and name are given. In that case, the scope can be found in the library.

A measure may be a refinement of another measure. The scope of the first measure is a subset of the second measure's scope. The characteristic of both measures must be identical.

## SuperClass

AbstractMeasureElement

---

**Issue:** SMM12-95 – Replace SMM “string” with UML/MOF “String”.

**Issue:** SMM12-92 – Inconsistent handling of inherited attributes.

**Issue:** SMM12-128 – Replace boolean with UML/MOF “Boolean”.

**Issue:** SMM12-89 – Better document rendering aspects of the measureLabelFormat and measurementLabelFormat of Measures.

---

## Attributes

name: <del>string-String</del> [1]	Specifies the unique name of the measure ( <del>inherited</del> ). This property redefines the name of SmmElement.
measureLabelFormat: <del>string-String</del> [0..1]	Specifies a <del>label-formatting-string</del> to use when rendering a label for this measure. See Semantics for detailed content format.
measurementLabelFormat: <del>string-String</del> [0..1]	Specifies a <del>label-formatting-string</del> to use when rendering labels for measurements of this measure. See Semantics for detailed content format.

visible: <del>boolean</del> Boolean [1]	Specifies if rendering tools should display this measure or not. Some measures whose role is only to help produce other measures will often be marked as non-visible. Defaults to true.
source: <del>string</del> String [0..1]	Specifies a defined or undefined measure which serves as the source of this measure.
scale:ScaleOfMeasurement [0..1]	Specifies the scale of measurement (nominal, ordinal, interval, ratio, or custom).

**Issue: SMM12-170 – Outbound associations wrongly defined**

## Associations

scope:Scope [1]	Specifies a set of elements measurable by this measure.
defaultQuery:Operation [0..1]	Specifies a query that is used to determine a default value for the measure in case we are dealing with a non-direct measure (i.e. a measure that depends on another for its value) where its base measure returns no children. This is a normal situation that can happen when certain optional “children” don’t exist.
equivalentFrom:EquivalentMeasureRelationship [0..*]	Specifies the relationship instance that defines the equivalency of this measure. This property subsets the inbound property of Measure.
equivalentTo: EquivalentMeasureRelationship [0..*]	Specifies the relationship instance that defines the equivalency of this measure. This property subsets the outbound property of Measure.
refinementFrom:RefinementMeasureRelationship [0..*]	Specifies the relationship instance that defines the refinement of this measure. This property subsets the inbound property of Measure.
refinementTo:RefinementMeasureRelationship [0..*]	Specifies the relationship instance that defines the refinement of this measure. This property subsets the outbound property of Measure.
category:MeasureCategory [0..*]	Specifies categories to which this measure belongs.
trait:Characteristic [1]	Specifies the trait characterized by this measure.
/inbound:MeasureRelationship [0..*]	The set of relationships such that the current Measure is the to-endpoint of these relations. This property is a derived union, subsets inRelationships and redefines inRelationships of SmmElement.
/outbound:MeasureRelationship [0..*]	The set of relationships such that the current Measure is the <del>from</del> endpoint of these relations. This property is a derived union, subsets outRelationships and redefines outRelationships of SmmElement.
measureRelationships:MeasureRelationship [0..*]	The set of all MeasureRelationship owned by the measure.

## Operations

getArguments:Argument [0..*]	This operation returns the set of arguments that the different operations of the measure have defined and got returned by getParamStrings().
getAllArguments:Argument [0..*]	This operation returns the set of arguments for this measure and any

	child measure required for the execution of the measure. It should call getArguments() on itself and every one of its child measures.
--	---

## Semantics

**Issue: SMM12-89 – Better document rendering aspects of the measureLabelFormat and measurementLabelFormat of Measures.**

The label formatting attributes, measureLabelFormat and measurementLabelFormat, specify the composition of labels for measures and measurements. ~~labelFormat~~The composition is based on the concept of format string used in many languages to assemble string content for rendering. Although beyond the scope of this specification to cover implementation details, this format also supports the use of external resource to provide i18N internationalization.

~~Just like format strings, the labelFormat is defined as a text portion with possible replacement expressed as argument index surrounded by French braces “{}”, where the zero-based index is matched with its corresponding replacement argument, which follow the text portion.~~

Label format specification has the form:

~~<“Template-Text”(<Context Object: OperationName, ContextObject.attribute,...<Argument>)\*~~

~~Just like format strings, <TemplateText> is a template label string with the labelFormat is defined as a text portion with possible replacements expressed expressed as argument indices ex surrounded by French braces “{}”, where the zero-based index is matched with its corresponding replacement <Argument>, which follow the text portion.~~

Examples of the label ~~<TemplateText> String Template~~ could be:

- “This is a label”                      A fixed string, in which case no arguments are necessary
- “This {1} of {0}”                      A label with replaceable arguments that will come from evaluating the corresponding argument from the list supplied (in numerical order, starting at 0)
- \$Resource:resource\_text\_constant      Here resource\_text\_constant would be replaced with a constant that will be matched in some resource location and for the proper locale (not defined here). The content returned by this resource resolution can be any valid label string template.

~~The argArguments of the label format are defined in a comma separated list. Each <of those Aargument>s must follow a specific pattern: expressed in There is a standard syntax and also a shorthand version syntax for some common cases.~~

The standard syntax, ~~which is always valid,~~ has the form

~~<ContextIdentifier>: <OperationName>~~

~~<ContextIdentifier > may be “Measurement”, “ObservedMeasure”, “Observation”, “Measure”, “Scope”, “Characteristic” or “UnitOfMeasure”. Each uniquely identifies a context object relative measurement. “Measurement” identifies the measurement itself; “ObservedMeasure” the measurement’s observedMeasure; “Observation” the Observation containing the measurement; “Measure” the observedMeasure’s measure; “Scope” the measure’s scope; “Characteristic” the measure’s trait; and “UnitOfMeasure” the measure’s unit.~~

~~starts by specifying a context object, followed by a literal colon “:”, then an <OperationName> operation whose names must be the name of a valid instance in the Operation class which when; performed in the context of object identified by <ContextIdentifier> returns a string.~~

~~ContextObject: It is the first part and it represents the Object that we are interested in collecting information from. This object is related or associated with the measurement such as the Scope or the measure or the measurand ...etc. It is important to understand here that the labelFormat is defined as part of the measure, but it is accessed normally from within the context of a measurement.~~

Formatted: Font: (Default) Courier New

Formatted: Font: (Default) Courier New

Formatted: Body

~~• OperationName: Defines the name of a valid instance of the Operation class that is designed to return a string.~~

The shorthand syntax has the form

<ContextIdentifier> . <PropertyName>

<ContextIdentifier> is as above. ~~is~~<PropertyName> is ~~an valid to get the value of attributes~~ in the context of object identified by <ContextIdentifier> which returns a string ~~from the current instance of measurement, measure and scope based on the current context of the initial measurement. This syntax calls for the use of a dotted notation being ContextObject.attributeName~~. For example, an argument can be ~~you could get~~ "Measure.name" or "ScopeObservation.whenObserved~~class~~" ~~directly~~.

The defaultQuery is designed to provide a way to specify a default value in the specific case where a non-direct measure (i.e. a measure that depends on another for its value) happens not to have any available value from what should have been its "base measure". In those case, the query should be execute to provide for the value instead of returning null or failing the measurement, as this is a normal situation that can happen when certain optional "children" don't exist.

Formatted: Indent: First line: 0.5"

## 9.610.6 UnitOfMeasure Class

The UnitOfMeasure class provides a representation for units of measure. A unit is a quantity in terms of which the magnitudes of other quantities within the same total order can be stated.

Units are expected to be standards which are heavily re-used. The SmmModel may contain a base, shared MeasureLibrary which contains these standard units. For example, one such MeasureLibrary could provide all the units of the British imperial system.

### SuperClass

AbstractMeasureElement

## 9.710.7 Operation Class

Operation is a subclass of AbstractMeasureElement which defines an operation to execute.

### SuperClass

AbstractMeasureElement

---

**Issue:** SMM12-95 – Replace SMM "string" with UML/MOF "String".

---

### Attributes

language: <del>string</del> String	Specifies the language of the operation. The language may be a computer language such as "OCL" or "XQuery" or a natural language such as "English", "French", etc.
body: <del>string</del> String	Specifies the measurement operation expressed in the selected language.

---

**Issue:** SMM12-95 – Replace SMM "string" with UML/MOF "String".

---

### Operations

getParamStrings: <a href="#">stringString</a> [0..*]	This operation returns the set of string that defines the parameter in use by an operation.
---	---

## Semantics

The operation body supports the use of replaceable parameters in order to support parameterized measures. This is accomplished by defining placeholders for incoming arguments that will be replaced at runtime with a specific value, like when dealing with date ranges for example.

The implementer is responsible, when using the measure library in an executable fashion, to determine based on the requested measures of his observation, what are all of the arguments that should be passed in with the observation in order to properly perform the measurements. The getArguments and getAllArguments operation of the Measure class are designed to help in this regard.

When parameters are used they must adhere to the following specification: '{ [typeName] parameterName [ '=' defaultValue " " ] }' where:

- typeName represents the type of the parameter. The typeName must be one of the types supported by the "type" attribute of the Argument class
- parameterName represents the name of the parameter (required)
- defaultValue represents a default value to offer (on getArguments()) or to use if not supplied as Argument to an observation. defaultValue is optional.

### 9.810.8 OCLOperation Class

OCLOperation is a subclass of AbstractMeasureElement which defines OCL helper methods.

#### SuperClass

AbstractMeasureElement

---

**Issue:** SMM12-95 – Replace SMM “string” with UML/MOF “String”.

---

#### Attributes

context: <a href="#">stringString</a> g	Specifies the classifier for which this helper is being defined. OCL inheritance rules applies to resolve applicability of operation, based on the passed in context
body: <a href="#">stringString</a>	Specifies the body of the OCL helper method.

## Semantics

The OCLOperation class allows for the definition and registration of OCL helper methods in the context of specific classifiers. These operations allow for the definition and reuse of often lengthy and complex OCL methods. It is the implementer’s responsibility to determine how to best provide for the parsing or execution environment of those methods. Any helper method that is defined with an OCLOperation then becomes available for OCL based operations applied to the proper classifier.

### 9.910.9 MeasureRelationship Class (abstract)

MeasureRelationship is an abstract class representing any relationship between two measures. See Figure 10.2.

## SuperClass

SmmRelationship

**Issue:** SMM12-95 – Replace SMM “string” with UML/MOF “String”.

**Issue:** SMM12-92 – Inconsistent handling of inherited attributes.

## Attributes

<del>name:string</del>	<del>Specifies the name of this measure relationship (inherited).</del>
influence:Influence [0..1]	Indicates whether the origin Measure positively or negatively influences the target Measure.

## Associations

from:Measure [1]	The origin element (also referred to as the from-endpoint of the relationship). This property redefines the from-endpoint of SmmRelationship.
to:Measure [1]	The target element (also referred to as the to-endpoint of the relationship). This property redefines the to-endpoint of SmmRelationship.
measurandQuery:Operation [0..1]	Specifies a query that is used to determine the measurands that satisfy the relation between two measures. It is most often used to specify the measurands that match a specific non-containment refinement relation between measures.

## Semantics

By default, relationships between measures have their meaning implied by their concrete subtype. The measurandQuery defines an optional way to describe this relationship by allowing the specification of a query operation that will return the specific measure instance that satisfies the query condition. It is mostly designed to be used with RefinementMeasureRelationship in order to provide a navigation that is different than the default containment mode.

## 9.1010.10 EquivalentMeasureRelationship Class

EquivalentMeasureRelationship is a class representing any relationship of equivalency between two measures. See Figure 10.2.

## SuperClass

MeasureRelationship

## Associations

from:Measure [1]	Specifies the equivalent measure at the from-endpoint of the relationship. This property redefines the from-endpoint of MeasureRelationship.
to:Measure [1]	Specifies the equivalent measure at the to-endpoint of the relationship. This property redefines the to-endpoint of MeasureRelationship.
mapping:Operation [0..1]	Specifies the mapping operation query that retrieves the “to” measure between a pair of equivalent measures, when each measure is represented



	by a different scope.
--	-----------------------

**Constraints**

```
context EquivalentMeasureRelationship inv:
influence.oclIsTypeOf(OclVoid)
```

**Semantics**

Defining a measure as being equivalent to another measure states that two measures are semantically indistinguishable. Any measurement result by one on a given entity under a given observation should equal a measurement by the other on the same or different entity as long as they are part of the same observation.

The semantics of this association is symmetric, but only one direction needs to be defined in a way that is resolvable, i.e. in a way that provides a path all of the way to base measures assigned against outside measurand. If a measure can't resolve to base measurements but is defined as equivalent to another measure, then it can use this equivalency to derive its own measurement result.

This means that when establishing the dependency graph for calculation, a measure can find its base measure not only through direct lineage, but also through measure equivalency. For example, calculating LOC at various levels in code can be defined against ASTM. Then we define that the ASTM CompilationUnit level LOC measure is equivalent to the KDM SourceFile LOC measure. This then allows for the SourceFile LOC measure to find its result through its equivalency relationship.

**9.11.11 RefinementMeasureRelationship Class**

Refinement MeasureRelationship is a class representing any relationship of refinement between two measures.

**SuperClass**

MeasureRelationship

**Associations**

from:Measure [1]	Specifies the measure at the from-endpoint of the relationship. This property redefines the from-endpoint of MeasureRelationship.
to:Measure [1]	Specifies the measure at the to-endpoint of the relationship. This property redefines the to-endpoint of MeasureRelationship.

**Constraints**

```
context RefinementMeasureRelationship inv:
influence.oclIsTypeOf(OclVoid)
```

**Semantics**

Throughout the remainder of this document we will say that a measure is a refinement of another measure if and only if the first is associated to the second as a refinement directly or transitively.

When this association is defined without a measurandQuery (from MeasureRelationship superclass), then it implies

that the from and to measure of the refinement are related through a containment relation where the from measure is the container and the to measure represents the content of the container.

When the refinement relation between the two measure classes is not a direct containment, then a measurandQuery should be used to provide the appropriate query to retrieve the related children in the scope of the 'to' measure.

## 9.1210.12 DimensionalMeasure Class (abstract)

This class models the specification of measures which assign numeric values that can be placed in order by magnitude. Dimensional measures have units of measures and their values span a dimension. See Figure 11.1.

The unit of measure is an archetypal or prototype element of the dimension. Every element of the dimension can be stated by a numerical multiple of the 'unit of measure' element.

The unit of measure does not distinguish between measures which share the same range. That distinction would be entirely within the purview of the measure identification. For examples, a height measure and a width measure may share the same unit of measure. That is to say, a measurement is not just a number and a unit of measure. The measured artifact must be indicated, the measure identified and contextual information retained as the observation.

### SuperClass

Measure

**Issue:** SMM12-95 – Replace SMM “string” with UML/MOF “String”.

**Issue:** SMM12-88 – The definition of Formula of DimensionalMeasure should be more generally specified.

### Attributes

formula: <del>string</del> String [0..1]	Describes the measure’s calculation in an algebraic manner or <b>pseudocode</b> . This attribute is an optional description of the measure. For example, “X + Y” or “Height * Width” are possible formulas. The decision to provide a formula would be entirely up to the SMM library designer. <b>Formulas are simply descriptive and not akin to operations which are operational and defined by a coherent program fragment for a stated programming language.</b>
--	---

**Issue:** SMM12-133 – “From” associations on Dimensional Measure/Measurement are poorly described.

### Associations

unit:UnitOfMeasure [1]	Specifies the unit of measure.
rankingFrom:RankingMeasureRelationship [0..*]	Specifies the relationship instances that defines the ranking <b>measures derived from <del>for</del></b> this measure. This property subsets the inbound property of Measure.
gradeFrom:GradeMeasureRelationship [0..*]	Specifies the relationship instances that defines the grade <b>measures derived from <del>for</del></b> this measure. This property subsets the inbound property of Measure.
baseMeasureFrom:BaseMeasureRelationship [0..*]	Specifies the relationship instances that defines the <b>accumulation-collective measures derived from <del>for</del></b> this measure. This property subsets the inbound property of Measure.
baseMeasureIFrom:BaseIMeasureRelationship [0..*]	Specifies the relationship instances that defines the 1 <sup>st</sup> part of the binary <b>measures derived from</b>

	<del>comparator for</del> this measure. This property subsets the inbound property of Measure.
baseMeasure2From:Base2MeasureRelationship [0..*]	Specifies the relationship instances that defines the 2nd part of the binary <del>measures derived from</del> <del>comparator for</del> this measure. This property subsets the inbound property of Measure.
rescaleTo:RescaledMeasureRelationship [0..*]	Specifies the relationship instance that defines the measure rescaling this measure. This property subsets the inbound property of Measure.

### 9.1310.13 GradeMeasure Class

This class represents simple range-based grading or classifications based upon already defined dimensional measures. See Figure 10.2

Examples are:

- Small, medium, large
- Cold, warm, hot
- A, B, C, D or F
- Reliable / Unreliable

---

**Issue: SMM12-105 – The wording “base measure(ment)” is ambiguous.**

---

Collectively the grade intervals may completely cover the ~~base-intervals~~ dimension or may leave gaps. A ~~base~~ measurement in such a gap is considered not graded and is not representable as a measurement of the grade measure.

The intervals may overlap. A grade resulting in a particular symbol means and only means that the ~~base-gradeTo~~ measure resulted in a value (~~possibly rescaled~~) occurring in a grade’s interval which mapped to that symbol. This does not exclude the possibility that the value might occur in another interval.

A GradeMeasure consists of mapping intervals to symbols where the intervals are parts of the underlying measure’s dimension. For example, 100 to 90 points maps to “A,” 80 up to 90 maps to “B,” 70 up to 80 maps to “C,” 60 up to 70 maps to “D,” and below 60 maps to “F.” The underlying dimension consists of grade points. The result is the usual A, B, C, D, and F style grade.

GradeMeasure may represent a purely qualitative evaluation with no quantitative ~~base-gradeTo~~ measure. For example we could measure the non-standardness of the source language and evaluate it without quantification. It is identified as “2GL,” “Unacceptable 3GL or 4GL,” “Acceptable 3GL or 4GL,” or “Ideal Strategic Language.” The first two are judged equivalently non-standard. The third is more nearly standard and the last is standard.

#### SuperClass

Measure

---

**Issue: SMM12-105 – The wording “base measure(ment)” is ambiguous.**

---

#### Associations

gradeTo:GradeMeasureRelationship [0..1]	Specifies the relationship instance that defines the measure ranked by this grade. This property subsets the outbound property of Measure.
interval:GradeInterval [1..*]	Identifies intervals within the <del>gradeTo’s</del> dimension ( <del>possibly rescaled</del> ) of the <del>base-measure</del> and the symbol to which each interval is mapped.

---

**Issue:** SMM12-105 – The wording “base measure(ment)” is ambiguous.

---

**Issue:** SMM12-87 – Relax constraint requiring both boundary points of an Interval.

---

## Constraints

```
econtext GradeMeasure inv:  
{gradeTo->notEmpty implies  
  interval->forall(i | not i.minimum.isOclUndefined() and  
                  not i.maximum.isOclUndefined())) and  
(interval->exists(i | i.minimum.isOclUndefined() or  
                  i.maximum.isOclUndefined())) implies  
  gradeTo->isEmpty}
```

If gradeTo is specified then every interval has at least one boundary specified and the boundaries' units are gradeTo.rescaledMeasure.unit when gradeTo.rescaledMeasure is specified and are gradeTo.to.unit otherwise.

## Semantics

Unit consistency between the grade intervals and their base measurement is required. If gradeTo is specified, the unit of measure for the boundaries (minimum and maximum) of a GradeMeasure's intervals is determined by the GradeMeasureRelationship specified by gradeTo.

### 9.1410.14 GradeMeasureRelationship Class

---

**Issue:** SMM12-105 – The wording “base measure(ment)” is ambiguous.

---

GradeMeasureRelationship is a class representing any relationship of grading between a grade measure (**from**) and a dimensional measure (**to**).

---

**Issue:** SMM12-105 – The wording “base measure(ment)” is ambiguous.

---

## SuperClass

ScaledBaseMeasureRelationship

## Associations

from:GradeMeasure [1]	Specifies the grade measure at the from-endpoint of the relationship. This property redefines the from-endpoint of MeasureRelationship.
to:DimensionalMeasure [1]	Specifies the dimensional measure at the to-endpoint of the relationship. This property redefines the to-endpoint of MeasureRelationship.

---

**Issue:** SMM12-87 – Relax constraint requiring both boundary points of an Interval.

---

### 9.1510.15 Interval Class (abstract)

This class represents an interval, the range of values from a minimum to a maximum. Either or both **boundaries** and **points** can be included or excluded. See Figure 10.2.

## SuperClass

SmmElement

## Attributes

maximumOpen:Boolean	True if and only if interval excludes maximum <del>endpoint</del> boundary. Default = false.
minimumOpen:Boolean	True if and only if interval excludes minimum <del>endpoint</del> boundary. Default = false.
maximum:Number [0..1]	Identifies interval's maximum <del>endpoint</del> boundary.
minimum:Number [0..1]	Identifies interval's minimum <del>endpoint</del> boundary.

## Constraints

```
context Interval inv:
  if not maximum.isOclUndefined and not minimum.isOclUndefined
  then minimum.isOclDefined and maximum ≥ minimum and
      (maximumOpen or minimumOpen → maximum > minimum)
  else not minimum.isOclDefined
```

### 9.1610.16 GradeInterval Class

This class represents the mapping of an interval to a symbol that serves as a grade. See Figure 10.2.

## SuperClass

Interval

---

**Issue:** SMM12-95 – Replace SMM “string” with UML/MOF “String”.

**Issue:** SMM12-105 – The wording “base measure(ment)” is ambiguous.

---

## Attributes

symbol: <del>string</del> String	<del>Base-Values</del> measurements within this interval are mapped <del>to</del> by symbol.
----------------------------------	--

---

**Issue:** SMM12-105 – The wording “base measure(ment)” is ambiguous.

---

### 9.1710.17 RankingMeasure Class

This class represents (as does the GradeMeasure) simple range-based ranking or classifications based upon already defined dimensional measures. See Figure 10.2. It differs from GradeMeasure in that RankingMeasures are DimensionalMeasures. The result of each ranking is a value within a dimension and can be used as such.

For example, one might use a RankingMeasure in mapping delivery time to “satisfaction” units. The delivery time satisfaction measurement can then be combined with other satisfaction measurements to get a customer total satisfaction measurement.

The ranking intervals, as with grading intervals, may collectively cover the ~~rankingTo.to base~~dimension (possibly ~~rescaled~~)-or may leave gaps. A ~~base~~ measurement in such a gap is considered not ranked and is not representable as a measurement of the ranking measure.

The intervals may overlap. A ranking resulting in a particular numeric value means and only means that the **base rankingTo.to** measure resulted in a value (possibly rescaled) occurring in a rank's interval which mapped to that numeric value. This does not exclude the possibility that the value might occur in another interval.

## SuperClass

DimensionalMeasure

## Associations

rankingTo:RankingMeasureRelationship [1]	Specifies the relationship instance that defines the measure ranked by this ranking.
interval:RankingInterval [1..*]	Identifies intervals within the <b>rankingTo.to</b> dimension (possibly rescaled) of the <b>base measure</b> and the symbol to which each interval is mapped.

**Issue:** SMM12-105 – The wording “base measure(ment)” is ambiguous.

**Issue:** SMM12-87 – Relax constraint requiring both boundary points of an Interval.

## Constraints

If **rankingTo.rescaledMeasure** is specified then the boundaries' unit is **rankingTo.rescaledMeasure.unit**. Otherwise, their unit is **rankingTo.to.unit**.

## Semantics

A central role for RankingMeasure is the translation of a measurement with one unit to a measurement of a different unit. Unit consistency **between the results of rankings and their base measurements** is consequently not enforced by the tool and is the responsibility of the measure library designer.

Unit consistency, however, between the ranking intervals and their base measurement is required. The unit of measure for the boundaries (minimum and maximum) of a RankingMeasure's intervals is determined by the RankingMeasureRelationship specified by **rankingTo**.

**Issue:** SMM12-105 – The wording “base measure(ment)” is ambiguous.

## 9-1810.18 RankingMeasureRelationship Class

RankingMeasureRelationship is a class representing any relationship of ranking between a ranking measure (**from**) and a base dimensional measure (**to**).

## SuperClass

ScaledBaseMeasureRelationship

## Associations

from:RankingMeasure [1]	Specifies the ranking measure at the from-endpoint of the relationship. This property redefines the from-endpoint of MeasureRelationship.
-------------------------	---

to:DimensionalMeasure [1]	Specifies the dimensional measure at the to-endpoint of the relationship. This property redefines the to-endpoint of MeasureRelationship.
---------------------------	---

**9.1910.19 RankingInterval Class**

This class represents the mapping of an interval to a number that serves as a rank. See Figure 10.2.

**SuperClass**

Interval

---

**Issue:** SMM12-105 – The wording “base measure(ment)” is ambiguous.

---

**Attributes**

value:Number	<del>Base-Values</del> measurements within this interval are mapped to this value.
--------------	--

---

**Issue:** SMM12-87 – Relax constraint requiring both boundary points of an Interval.

---

**Constraints**

```
context RankingInterval inv:
maximum.isOclDefined
context Interval inv: (not maximum.isOclUndefined or not
minimum.isOclUndefined)
```

**9.2010.20 Influence Data Type (enumeration)**

The Influence enumeration defines Influence – a property of MeasureRelationship. See Figure 10.2. The Influence property provides a quick understanding of how measures influence each other.

**Literal Values**

- Positive
- Negative

**9.2110.21 ScaleOfMeasurement Data Type (enumeration)**

The scale of measurement classifies the measure into four levels: nominal, ordinal, interval or ratio. ScaleofMeasurement may be used to develop taxonomy of measures.

**Literal Values**

- nominal
- ordinal
- interval
- ratio
- custom

Nominal scale measures differentiate measured objects based upon their categorical equivalence. Classification by gender, favorite color, and religion are nominal scales. Ordinal scales provide sorting of the measured objects, but do not allow for relative degree of difference between them. Customer service satisfaction surveys are often ordinal scales with, e.g., values of “Very Unsatisfied”, “Somewhat Unsatisfied”, “Neutral”, “Satisfied”, and “Very Satisfied”. The median is meaningful for ordinal scales.

Measures at the interval scale or level have units of measure. That is, they are DimensionalMeasures. Sums and differences of interval scale measurements are meaningful as are means and standard deviations. Their zero may not, however, be the lowest value of the scale. Celsius, Fahrenheit, elevation (height above/below sea level), pH, time of day are interval scales.

---

**Issue: SMM12-153 – Scalar misused in attributes subclass of RescaledMeasure Class.**

---

Ratio scale measures are DimensionalMeasures with absolute zeros. Kelvin, net loss and net gain are ratio scales. ~~Scalar~~ Multiples are permissible with ratio scales. One can say half as hot or twice as profitable. The coefficient of variation is meaningful for ratio scales as their measurements are always non-negative values.

Custom allows measure library designers to extend ScaleOfMeasurement to include other scales.

## Semantics

The four levels of scales of measurement are cumulative. Ordinal implies nominal; interval implies ordinal; and ratio implies interval.

All SMM measures are nominal scale measures. Asserting that a measure is an ordinal scale measure implies the existence of a sorting of the measured objects based upon their measurements.

All DimensionalMeasures are interval scale measures. Asserting that a DimensionalMeasure is a ratio scale measure implies that the dimension’s zero is absolute.



# 4011 Collective Measures

## 40.111.1 General

Figure 11.1 This diagram represents measures which assess container entities by accumulating assessments of contained entities which are found by the base measure. See demonstration given in Figure 11.2.

Most engineering measures are collective. We count up lines of code for each program block and sum these values to measure routines, programs and eventually applications. A similar process is followed to count operators, operands, operator and operand occurrences, independent paths, and branching points.

Other frequently used container measures are based upon finding the maximum measurement of the container's elements. Nesting depth in a program and class inheritance depth exemplify these collective measures.

The collective measure specifies the following measurement process:

1. Apply the base measure to each contained element to obtain a set of base measurements.
2. Apply the n-ary accumulator to the set of base measurements to obtain the measurement of the container.

Figure 11.2 demonstrates this process, with simplified associations.

**Issue: SMM12-95 – Replace SMM “string” with UML/MOF “String”.**

**Issue: SMM12-97 – SMM class for unit of measure of counting measures.**

**Issue: SMM12-105 – The wording “base measure(ment)” is ambiguous.**

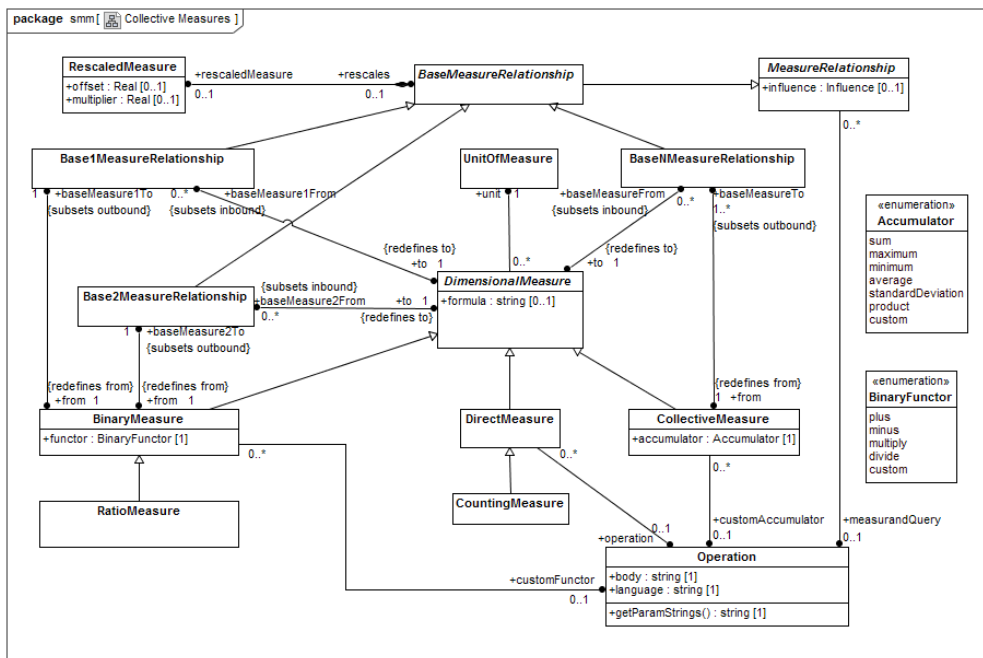

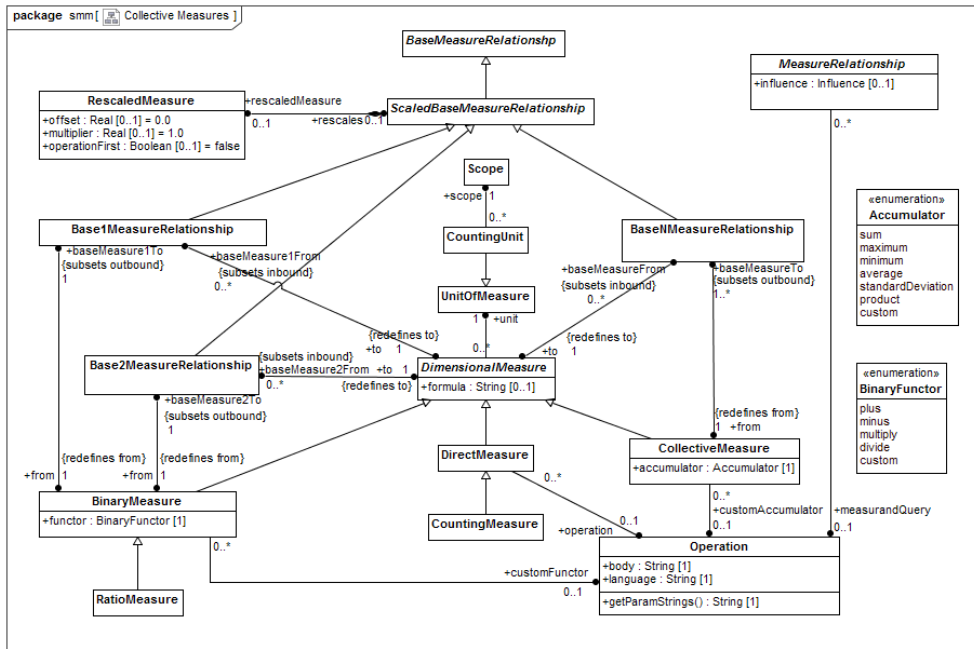

Figure 11.1 - Collective Measures

**Issue:** SMM12-160 – Fix and improve CollectiveMeasurement examples.

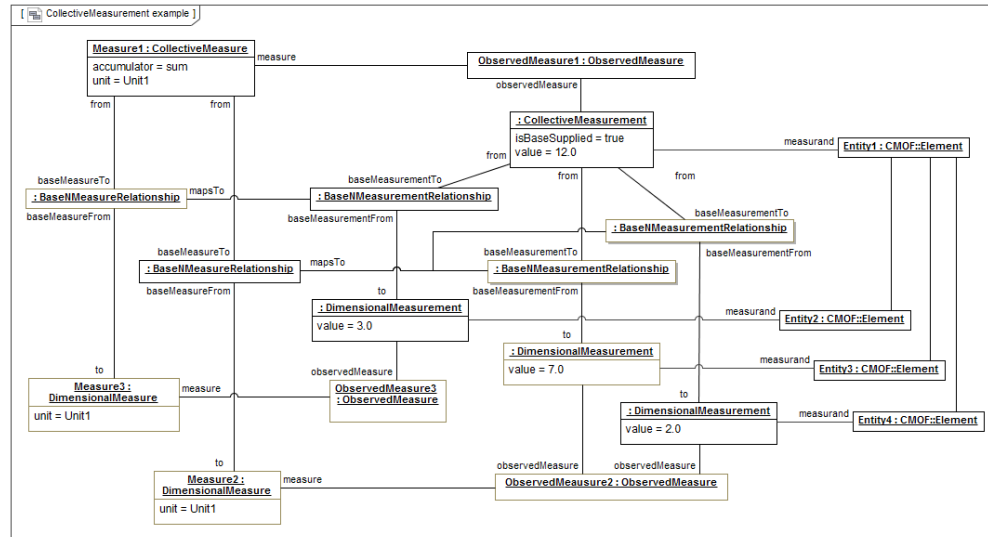
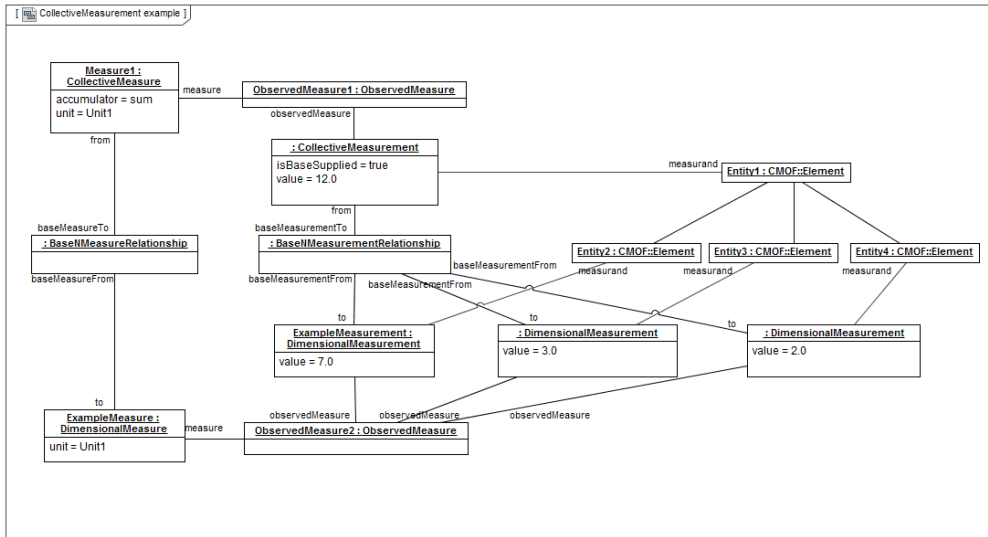

Figure 11.2 - CollectiveMeasurement example

## 40.211.2 CollectiveMeasure Class

The CollectiveMeasure class represents measures which when applied to a given entity accumulates measurements of entities similarly related to the given entity. See Figure 11.1. For example, counts for container entities are often found by accumulating (adding) counts of the containers' contained entities. In fact, sizing measures generally accumulate to containers by adding the results of applying the appropriate size measure to the contained entities.

Maximum is another frequent accumulator.

**Issue:** SMM12-150 – SMM is presumptuous about how measurands must relate

The measurands of the base measurements need not be the same as of the measurand of the collective measurement.

Within SMM, the measurands are ~~just arbitrary MOF::Elements~~ objects declared in another MOF or UML model. The SEI Maintainability Index is one such aggregation that does not change the unit of measure.

## SuperClass

DimensionalMeasure

## Attributes

accumulator:Accumulator	Identifies the n-ary or custom function that accumulates the base measurements.
-------------------------	---

## Associations

baseMeasureTo:BaseNMeasureRelationship [1..*]	Specifies the relationship instance that defines the measure accumulated by this collective measure. This property subsets the outbound property of Measure.
customAccumulator:Operation [0..1]	Specifies the measurement operation of this measure.

## Constraints

```
Context CollectiveMeasure inv:
(accumulator<>Accumulator::custom implies customAccumulator ->isEmpty)
and (accumulator=Accumulator::custom implies customAccumulator->notEmpty)
```

If the accumulator is sum, maximum, minimum, average or standardDeviation then all of the base measures' units MUST be consistent with the collective measure's unit. If baseMeasureTo.rescaledMeasure is specified then baseMeasureTo.rescaledMeasure.unit MUST be identical to collective measure's unit. Otherwise baseMeasureTo.to.unit MUST be identical to the collective measure's unit.

---

**Issue: SMM12-91 – Move constraint on the “product” accumulator in CollectiveMeasure to CollectiveMeasurement.**

---

~~If the accumulator is product, then each of the base measures' units MUST be scalar. If baseMeasureTo.rescaledMeasure is specified then baseMeasureTo.rescaledMeasure.unit MUST be scalar. Otherwise baseMeasureTo.to.unit MUST be scalar.~~

## Semantics

Collective measures have operations (customAccumulator) if and only if their accumulators are custom.

When the accumulator is custom, unit consistency cannot be enforced by the tool and is the responsibility of the measure library designer.

### 40.311.3 Accumulator Data Type (enumeration)

The Accumulator enumeration defines DirectMeasure – a subclass of DimensionalMeasure which applies a given

operation to the measured entity. See Figure 11.1.

### Literal Values

- sum
- minimum
- maximum
- average
- standardDeviation
- product
- custom

## 40.411.4 BinaryFuncor Data Type (enumeration)

The BinaryFuncor enumeration defines the binary funcor applied to 2 base measurements to compute a binary measurement.

### Literal Values

- plus
- minus
- multiply
- divide
- custom

## 40.511.5 DirectMeasure Class

DirectMeasure – a subclass of DimensionalMeasure which applies a given operation to the measured entity. See Figure 11.1.

### SuperClass

DimensionalMeasure

### Associations

operation:Operation [0..1]	Specifies the measurement operation of this measure.
----------------------------	--

---

**Issue:** SMM12-119 – CountingMeasure operation should not be confused with Scope.recognizer

---

## 40.611.6 CountingMeasure Class

CountingMeasure is a subclass of DirectMeasure where the given operation returns 0 or 1 based upon recognizing whether the measured entity should be counted. See Figure 11.1.

### SuperClass

DirectMeasure

---

**Issue:** SMM12-97 – SMM class for unit of measure of counting measures.

---

### Constraints

```
context CountingMeasure::self.operation(unit):int  
post: result = 0 or result = 1
```

```
context CountingMeasure inv:  
unit.oclIsTypeOf(CountingUnit)and scope=unit.scope
```

See Figure 11.3.

---

**Issue:** SMM12-97 – SMM class for unit of measure of counting measures.

---

### Semantics

The operation is a ~~recognizer~~ counter that ~~selects some subset of the elements of the measure's scope found by self.scope. The recognizer~~ returns 1 for some subset of ~~the~~ elements in the measure's scope ~~of the subset. It and~~ returns 0 otherwise. ~~self.unit need not be an element of the subset.~~

---

**Issue:** SMM12-97 – SMM class for unit of measure of counting measures.

---

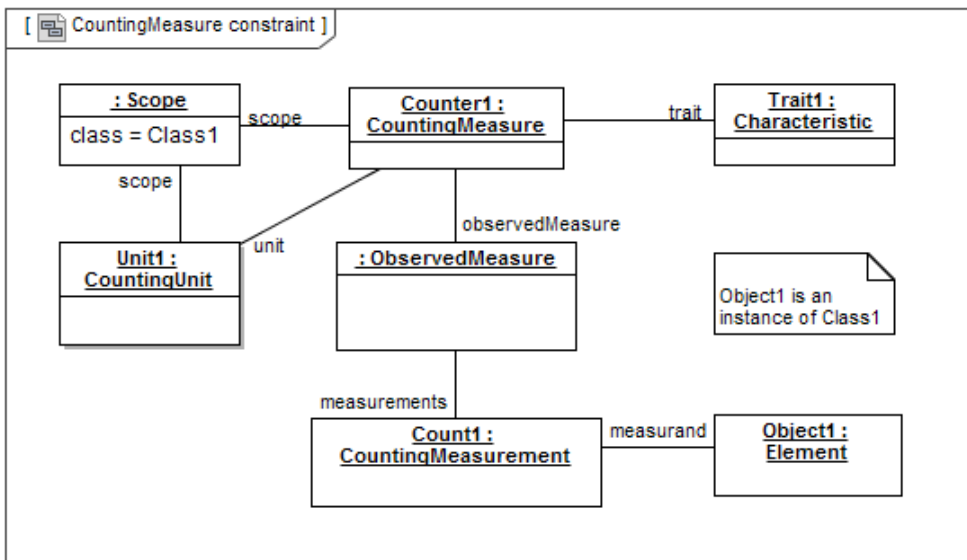
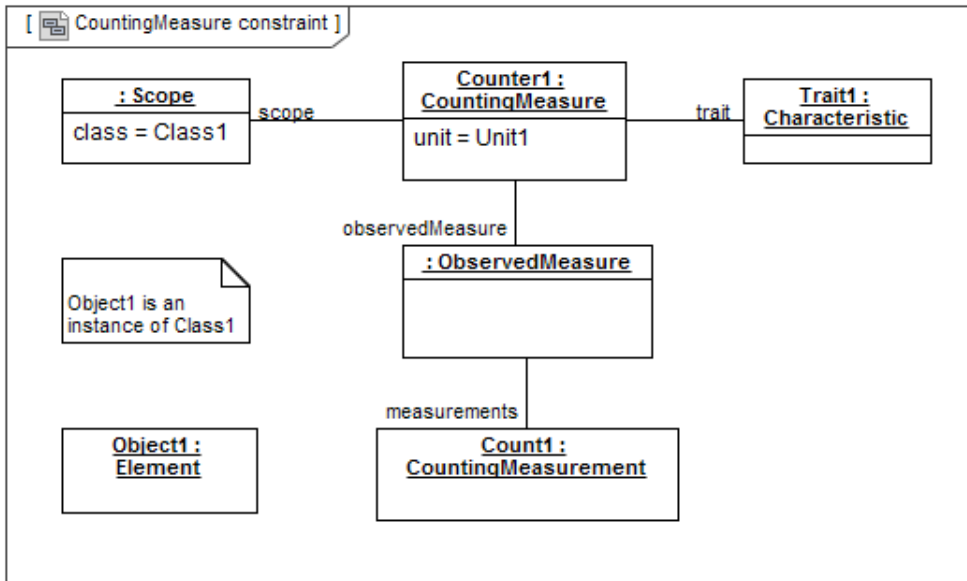

Figure 11.3 - CountingMeasure Unit of Measure Constraint

### 40.711.7 BinaryMeasure Class

**Issue:** SMM12-94 – Replace “accumulate” variants with “combine” concerning binary measures.

The BinaryMeasure class represents measures which when applied to a given entity ~~accumulates~~ combines measurements of two entities related to the given entity. See Figure 11.1. For example, areas for two dimensional entities are often found by ~~accumulating~~ combining (multiplying) lengths.

**Issue: SMM12-150 – SMM is presumptuous about how measurands must relate**

**Issue: SMM12-165 – Binary measurement, not collective measurement**

The measurands of the base measurements need not be the same as the measurand of the ~~collective~~-binary measurement. Measurands are objects declared in another MOF or UML model.

## SuperClass

DimensionalMeasure

## Attributes

functor:BinaryFunctor [1]	Identifies the binary function that combines two base measurements.
---------------------------	---

**Issue: SMM12-94 – Replace “accumulate” variants with “combine” concerning binary measures.**

## Associations

baseMeasure1To: Base1MeasureRelationship [1]	Specifies the relationship instance that defines the first measure <del>accumulated</del> -combined by this binary measure. This property subsets the outbound property of Measure.
baseMeasure2To: Base2MeasureRelationship [1]	Specifies the relationship instance that defines the second measure <del>accumulated</del> -combined by this binary measure. This property subsets the outbound property of Measure.
customFunctor:Operation [0..1]	Specifies the measurement operation of this measure.

## Constraints

```
Context BinaryMeasure inv:  
(functor <> BinaryFunctor::custom implies customFunctor->isEmpty)  
and (functor = BinaryFunctor::custom implies customFunctor->isEmpty)
```

If the functor is ‘plus’ or ‘minus’, then both base measures’ units MUST be consistent with the binary measure’s unit.

If baseMeasure1To.rescaledMeasure is specified then  
baseMeasure1To.rescaledMeasure.unit MUST be identical to binary measure’s unit.  
Otherwise baseMeasure1To.to.unit MUST be identical to the binary measure’s unit.

If baseMeasure2To.rescaledMeasure is specified then  
baseMeasure2To.rescaledMeasure.unit MUST be identical to binary measure’s unit.  
Otherwise baseMeasure2To.to.unit MUST be identical to the binary measure’s unit.

If the functor is ‘multiply’, then the binary measure’s unit MUST be equivalent to the product of the base measures’ units (after re-scaling if present) as shown in the table below.

rescaledMeasure specified for baseMeasure1To	rescaledMeasure specified for baseMeasure2To	Binary measure’s unit equivalent
No	No	baseMeasure1To.to.unit * baseMeasure2To.to.unit



No	Yes	$\text{baseMeasure1To.to.unit} * \text{baseMeasure2To.rescaledMeasure.unit}$
Yes	No	$\text{baseMeasure1To.rescaledMeasure.unit} * \text{baseMeasure2.to.unit}$
Yes	Yes	$\text{baseMeasure1To.rescaledMeasure.unit} * \text{baseMeasure2to.rescaledMeasure.unit}$

If the functor is 'divide', then the binary measure's unit MUST be equivalent to the unit of the first base measure (after re-scaling if present) divided by the unit of the second base measure (after re-scaling if present) as shown in the table below.

rescaledMeasure specified for baseMeasure1To	rescaledMeasure specified for baseMeasure2To	Binary measure's unit equivalent
No	No	$\text{baseMeasure1To.to.unit} / \text{baseMeasure2To.to.unit}$
No	Yes	$\text{baseMeasure1To.to.unit} / \text{baseMeasure2To.rescaledMeasure.unit}$
Yes	No	$\text{baseMeasure1To.rescaledMeasure.unit} / \text{baseMeasure2To.to.unit}$
Yes	Yes	$\text{baseMeasure1To.rescaledMeasure.unit} / \text{baseMeasure2To.rescaledMeasure.unit}$

## Semantics

The usual semantics of algebra would require that the unit of a binary measure equals applying the accumulator to the units of the base measures. While conforming to this requirement would ensure more easily understood models, SMM does not enforce this requirement.

When the functor is custom, unit consistency cannot be enforced by the tool and is the responsibility of the measure library designer.

A binary measure has an operation if and only if its functor is custom. For a binary measure the context is a measurand and a pair of base measurements.

### 40.811.8 RatioMeasure Class

This class represents those measures that are ratios of two base measures. See Figure 11.1. Examples include:

- Average lines of code per module,
- Failures per day,
- Uptime percentage – Uptime divided by total time,
- Business data percentage of all data,
- Halstead level = Halstead volume divided by potential volume,
- Halstead effort = Halstead level divided by volume.

A RatioMeasure and its two base measures frequently characterize three different traits of the same entity. If the dividend characterized the total code length of an application and the divisor characterized the number of program in the application then the ratio characterizes the average code length per program.

Ratios may also characterize traits of distinct entities. For example, a ratio may contrast the code length between a pair of programs.

---

**Issue:** SMM12-144 – Superclass of RatioMeasure should be BinaryMeasure

---

## SuperClass

~~DimensionalMeasure~~ BinaryMeasure

## Constraints

```
context MaximalMeasure inv:  
functor = 'BinaryFunctor.divide'
```

---

**Issue:** SMM12-105 – The wording “base measure(ment)” is ambiguous.

---

## ~~10.911.9~~ BaseMeasureRelationship Class (abstract)

BaseMeasureRelationship is a class representing relationship of hierarchy between a derived measure and its base measures.

~~The rescaledMeasure association provides a mechanism for a change in dimension from that of the base measure, to apply a weight factor, to flip the sign, or other linear adjustments.~~

## SuperClass

MeasureRelationship

---

**Issue:** SMM12-105 – The wording “base measure(ment)” is ambiguous.

---

## 11.10 ScaledBaseMeasureRelationship Class

ScaledBaseMeasureRelationship is a class representing relationship of hierarchy between a derived measure and its possibly rescaled base measures.

The rescaledMeasure association provides a mechanism for a change in dimension from that of the base measure, to apply a weight factor, to flip the sign, or other linear adjustments.

## SuperClass

BaseMeasureRelationship

## Associations

rescaledMeasure:RescaledMeasure [0..1]	Specifies the rescaled measure which defines a linear adjustment which may translate from the base measure's dimension (unit of measure) to the derived measure's dimension or apply a weight factor.
---	---

---

**Issue:** SMM12-105 – The wording “base measure(ment)” is ambiguous.

---

### 40.1011.11 BaseMeasureRelationship Class

BaseMeasureRelationship is a class representing relationship of hierarchy between a collective measure and a dimensional measure.

---

**Issue:** SMM12-105 – The wording “base measure(ment)” is ambiguous.

---

#### SuperClass

ScaledBaseMeasureRelationship

#### Associations

from:CollectiveMeasure [1]	Specifies the collective measure at the from-endpoint of the relationship. This property redefines the from-endpoint of MeasureRelationship.
to: DimensionalMeasure [1]	Specifies the dimensional measure at the to-endpoint of the relationship. This property redefines the to-endpoint of MeasureRelationship.

---

**Issue:** SMM12-105 – The wording “base measure(ment)” is ambiguous.

---

### 40.1111.12 Base1MeasureRelationship Class

Base1MeasureRelationship is a class representing relationship of hierarchy between a binary measure and a dimensional measure.

---

**Issue:** SMM12-105 – The wording “base measure(ment)” is ambiguous.

---

#### SuperClass

ScaledBaseMeasureRelationship

#### Associations

from:BinaryMeasure [1]	Specifies the binary measure at the from-endpoint of the relationship. This property redefines the from-endpoint of MeasureRelationship.
to: DimensionalMeasure [1]	Specifies the dimensional measure at the to-endpoint of the relationship. This property redefines the to-endpoint of MeasureRelationship.

---

**Issue:** SMM12-105 – The wording “base measure(ment)” is ambiguous.

---

### 40.1211.13 Base2MeasureRelationship Class

Base2MeasureRelationship is a class representing relationship of hierarchy between a binary measure and a dimensional measure.

---

**Issue:** SMM12-105 – The wording “base measure(ment)” is ambiguous.

---

#### SuperClass

### Associations

from:BinaryMeasure [1]	Specifies the binary measure at the from-endpoint of the relationship. This property redefines the from-endpoint of MeasureRelationship.
to: DimensionalMeasure [1]	Specifies the dimensional measure at the to-endpoint of the relationship. This property redefines the to-endpoint of MeasureRelationship.

---

**Issue:** SMM12-97 – SMM class for unit of measure of counting measures.

---

### 11.14 CountingUnit Class

The CountingUnit class provides a representation of a unit for counting members of a scope.

#### SuperClass

UnitOfMeasure

#### Associations

scope:Scope [1]	Specifies a set of elements each of which is counted as a unit.
-----------------	---

## 11.12 Other Measures

### 11.12.1 General

The following diagram presents three additional measures.

- Direct applications of named measurements. (One such named measure is Cyclomatic Complexity.)
- Simple algebraic change of scales of already defined numeric measures (e.g. the translation to ‘choice points’ from Cyclomatic complexity).

---

**Issue:** SMM12-95 – Replace SMM “string” with UML/MOF “String”.

**Issue:** SMM12-90 – Allow more flexibility in defining a RescaledMeasure.

**Issue:** SMM12-92 – Inconsistent handling of inherited attributes.

**Issue:** SMM12-105 – The wording “base measure(ment)” is ambiguous.

---

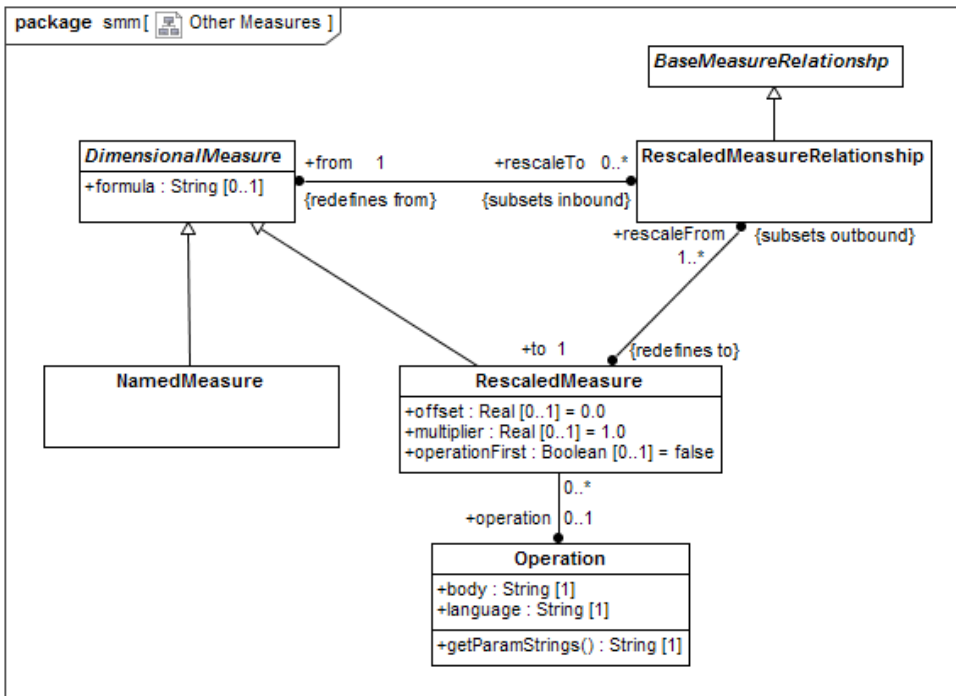
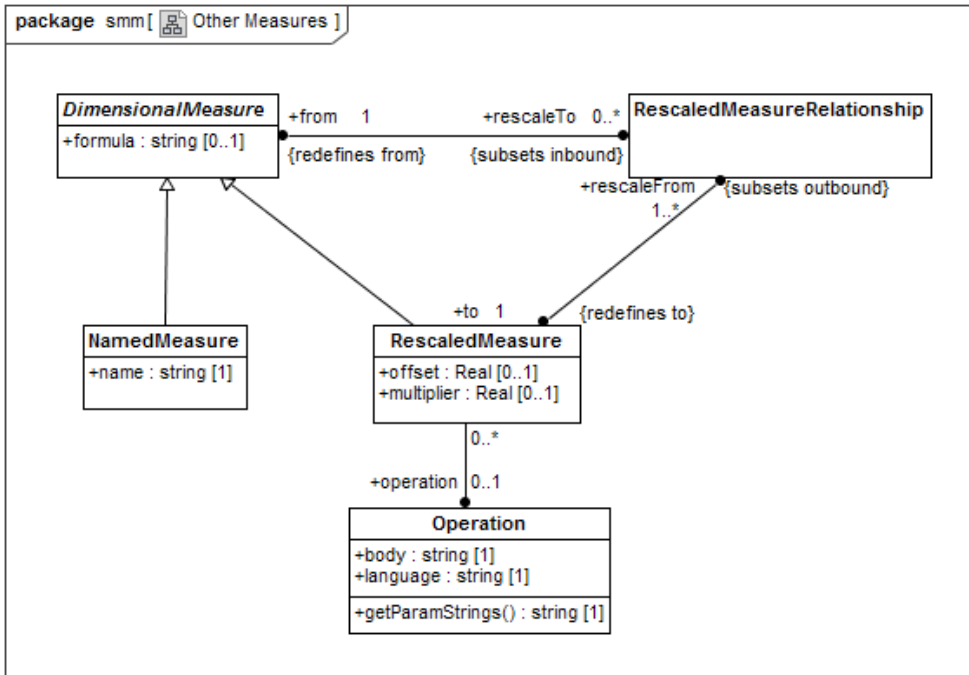

Figure 12.1 - Other Measures

## 11.212.2 NamedMeasure Class

The class allows for specifying measures which are well-known and can be specify simply by name. See Figure 12.1. For example, McCabe’s cyclomatic complexity. The meaning of applying the named measure should be generally accepted.

SMM is for the exchange of measurement results. To convey such results for well-known measures, it suffices to identify the measure solely by name.

### SuperClass

DimensionalMeasure

**Issue:** SMM12-92 – Inconsistent handling of inherited attributes.

### Attributes

name:string	Specifies the name of the SMM element. This attribute is inherited from the SmmElement class where it is optional. Here it is required.
-------------	---

### Constraints

```
context NamedMeasure inv:
not self.name->isEmpty
```

## 11.312.3 RescaledMeasure Class

The measure specifies a process that re-scales a measurement on an entity with one unit of measure to obtain a second measurement of the same entity with a different unit of measure. The RescaledMeasure class can also be used to apply a weight factor, to flip the sign, or make other linear adjustments. Non-linear adjustments may be specified with an Operation. See Figure 12.1.

### SuperClass

DimensionalMeasure

**Issue:** SMM12-90 – Allow more flexibility in defining a RescaledMeasure.

**Issue:** SMM12-153 – Scalar misused in attributes subclause of RescaledMeasure Class.

### Attributes

offset:Real [0..1] = 0.0	Specifies an <del>scalar</del> offset (a) which along with the multiplier (b) defines a linear re-scaling $(b*m)+a$ to obtain an adjusted value from a base measurement (m).
multiplier:Real [0..1] = 1.0	Specifies a <del>scalar</del> multiplier (b) which along with the offset (a) defines a linear re-scaling $(b*m)+a$ to obtain an adjusted value from a base measurement (m).
operationFirst:Boolean[0..1] = false	Specifies order of application of the operation (if given) and the offset and multiplier.

**Issue:** SMM12-94 – Replace “accumulate” variants with “combine” concerning binary measures.

**Issue:** SMM12-127 – Bad definition of rescales association in 12.3 RescaledMeasure Class

**Issue:** SMM12-105 – The wording “base measure(ment)” is ambiguous.

## Associations

rescaleFrom:RescaledMeasureRelationship [1..*]	Specifies the relationship instances that define the measures rescaled by this RescaledMeasure. This property subsets the outbound property of Measure.
operation:Operation [0..1]	Specifies the measurement adjustment operation of this measure.
rescales:BaseMeasureRelationship [0..1]	Specifies the relationship instance that defines <del>the base</del> <b>measure and derived measure that is derived from the base measure after being rescaled by which accumulates the base measure specified by rescaleFrom rescaled of</b> this measure.

**Issue:** SMM12-90 – Allow more flexibility in defining a RescaledMeasure.

## Constraints

~~Context RescaledMeasure inv:  
(offset->notEmpty or multiplier->notEmpty  
implies operation->isEmpty)  
and (offset->isEmpty or multiplier->isEmpty  
implies operation->isEmpty)~~

If rescales is specified then there MUST exist a rescaledFrom, from that equals rescales, to.

All UnitOfMeasures in the collection rescaleFrom, from, unit MUST be the same UnitOfMeasure.

**Issue:** SMM12-90 – Allow more flexibility in defining a RescaledMeasure.

## Semantics

A central role for RescaledMeasure is the translation of a measurement with one unit to a measurement of a different unit. Unit consistency is consequently not enforced by the tool and is the responsibility of the measure library designer.

~~Rescaled measures have operations if and only if their multipliers and offsets are not given.~~ For rescaled measure the context is a measurand and a base measurement. If operationFirst is true, operation is applied to the base measurement value first, the result is, secondly, multiplied by multiplier and offset is added last. Otherwise, the base measurement value is first multiplied by multiplier, offset is added second and operation (if given) is applied last.

### 11.412.4 RescaledMeasureRelationship Class

RescaledMeasureRelationship is a class representing relationship of measure rescaling between a rescaled measure and a dimensional measure.

**Issue:** SMM12-105 – The wording “base measure(ment)” is ambiguous.

## SuperClass

### Associations

from: DimensionalMeasure [1]	Specifies the dimensional measure at the from-endpoint of the relationship. This property redefines the from-endpoint of MeasureRelationship.
to: RescaledMeasure [1]	Specifies the rescaled measure at the to-endpoint of the relationship. This property redefines the to-endpoint of MeasureRelationship.



# 1213 Measurements

## 12.113.1 General

Measurement results are values from ordered sets. Such a set may be nominal (e.g. Poor, Fair, Good, Excellent) as long as there is an underlying order. A set may instead define a dimension where its values may be stated in orders of magnitude with respect to archetypal member. SMM allows for dimensional measurements. The magnitude is the measure's unit of measure.

SMM also allows for dimensionless measurements derived by ratios and grade schemes. In the former the ratio is derived from two measurements of the same dimension; whereas, in the latter measurements from a dimension are mapped to symbolic representations (e.g., 100-90 becomes "A", 89-80 becomes "B").

The modeling of measurements mirrors the modeling of measure.

**Issue: SMM12-95 – Replace SMM "string" with UML/MOF "String".**

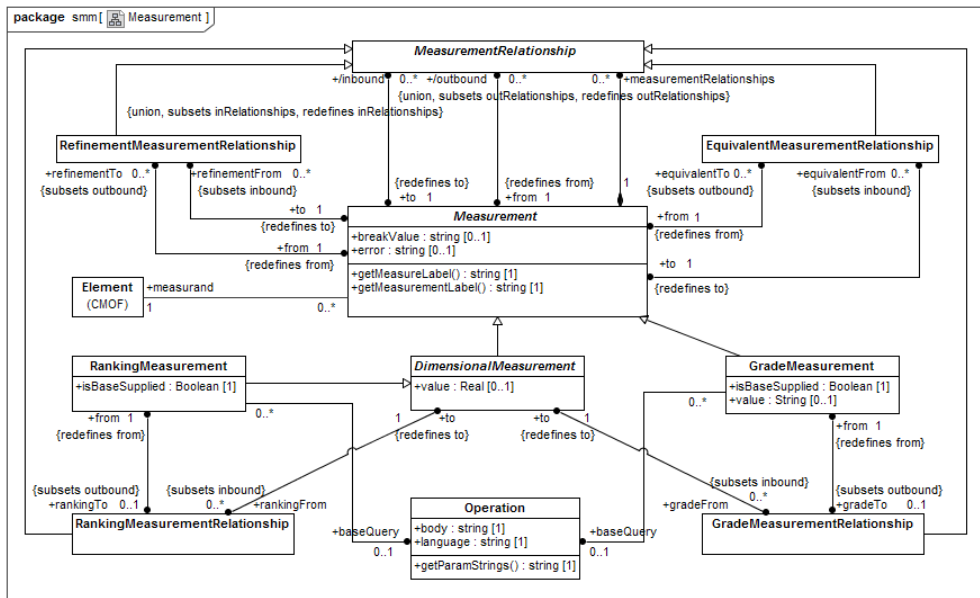

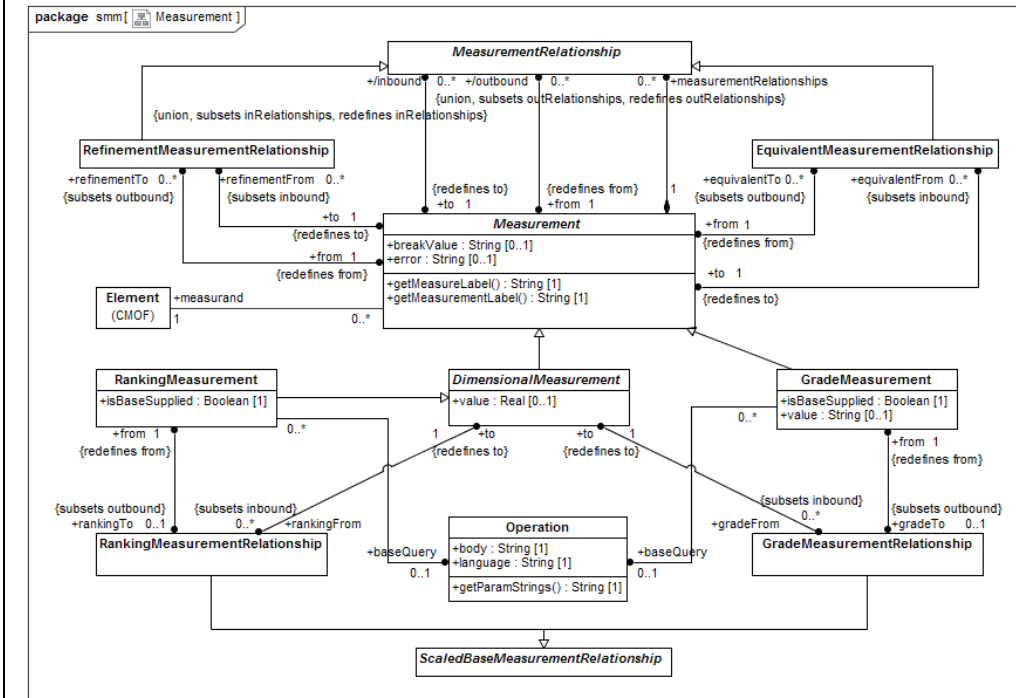

Figure 13.1 - Measurements

## 42.213.2 Measurement Class (abstract)

**Issue: SMM12-150** – SMM is presumptuous about how measurands must relate

The Measurement class represents the results of applying the associated Measure to the associated Measurand. See Figure 13.1. Two measurements of the same measurand by the same measure can be distinguished by observation information provided by the associated Observation. **Measurands are objects declared in another MOF or UML model.**

Measurand is in the scope of the measure.

The value of a measurement is an element of an ordered set. It may be a number where the ordering is the usual standard. The DimensionalMeasurement subclass of Measurement, as defined below, has a numeric value. The value may also be a symbol that we can map to a numeric interval. The GradeMeasurement subclass has a symbolic value.

Measure is a process and, hence, may fail. The error attribute of measurement allows such failures to be noted. A measurement either has a value or an error is recorded.

### SuperClass

SmmElement

**Issue: SMM12-95** – Replace SMM “string” with UML/MOF “String”.

### Attributes

error: <del>string-String</del> [0..1]	If an error occurred in the measurement process, this field contains a code representing the error.
breakValue: <del>string-String</del> [0..1]	If the scope specifies a break condition, this field contains the instance value associated with the break condition.

---

**Issue: SMM12-170 – Outbound associations wrongly defined**

---

**Associations**

measurand:MOF::Element [1]	Identifies the object measured. This property is owned by the association between Measurement and Element.
observedMeasure:ObservedMeasure [1]	Identifies the ObservedMeasure which contains the measurement.
equivalentFrom:EquivalentMeasurementRelationship [0..*]	Specifies the relationship instance that defines the equivalency of this measurement. This property subsets the inbound property of Measurement.
equivalentTo: EquivalentMeasurementRelationship [0..*]	Specifies the relationship instance that defines the equivalency of this measurement. This property subsets the outbound property of Measurement.
refinementFrom:RefinementMeasurementRelationship [0..*]	Specifies the relationship instance that defines the refinement of this measurement. This property subsets the inbound property of Measurement.
refinementTo:RefinementMeasurementRelationship [0..*]	Specifies the relationship instance that defines the refinement of this measurement. This property subsets the outbound property of Measurement.
/inbound:MeasurementRelationship [0..*]	The set of relationships such that the current Measurement is the to-endpoint of these relations. This property is a derived union, subsets inRelationships and redefines inRelationships of SmmElement.
/outbound:MeasurementRelationship [0..*]	The set of relationships such that the current Measurement is the <del>from</del> -endpoint of these relations. This property is a derived union, subsets outRelationships and redefines outRelationships of SmmElement.
measurementRelationships:MeasurementRelationship [0..*]	The set of all MeasurementRelationship owned by the measure.

---

**Issue: SMM12-95 – Replace SMM “string” with UML/MOF “String”.**

---

**Operations**

getMeasureLabel: <del>string-String</del> [1]	This operation returns the label describing the measure of this measurement according to the rule specified in measureLabelFormat in the Measure class.
getMeasurementLabel: <del>string-String</del> [1]	This operation returns the label describing this measurement and measurand according to the rule specified in measurementLabelFormat in the Measure class.

**Constraints**

```
context Measurement inv:
scope.breakCondition->isEmpty == breakValue->isEmpty
```

## Semantics

Measurand must be in the scope of measure. Specifically, if `measure.scope.class` is specified then measurand must be an instance of Element (CMOF) named in `measure.scope.class`. If `measure.scope.stereotype` is specified then measurand must be an instance of Element (CMOF) named in `measure.scope.stereotype`. If neither `measure.scope.class` nor `measure.scope.stereotype` is specified, then measurand should match the description specified in `measure.scope.description`.

If `measure.scope.recognizer` is given then the recognizer applied to the measurand must return true. The association between Measurement and Element owns measurand which means meta-models extending SMM may create their own specialized associations to restrict measurand to the metaclasses in their own meta-model.

### 42.313.3 MeasurementRelationship Class (abstract)

MeasurementRelationship is an abstract class representing any relationship between two measurements. See Figure 13.1.

#### SuperClass

SmmRelationship

#### Associations

from:Measurement [1]	Specifies the measurement at the from-endpoint of the relationship. This property redefines the from-endpoint of SmmRelationship.
to:Measurement [1]	Specifies the measurement at the to-endpoint of the relationship. This property redefines the to-endpoint of SmmRelationship.

### 42.413.4 EquivalentMeasurementRelationship Class

EquivalentMeasurementRelationship is a class representing any relationship of equivalency between two measurements.

#### SuperClass

MeasurementRelationship

#### Associations

from:Measurement [1]	Specifies the equivalent measurement at the from-endpoint of the relationship. This property redefines the from-endpoint of MeasurementRelationship.
to:Measurement [1]	Specifies the equivalent measurement at the to-endpoint of the relationship. This property redefines the to-endpoint of MeasurementRelationship.

## 42.513.5 RefinementMeasurementRelationship Class

Refinement MeasurementRelationship is a class representing any relationship of refinement between two measurements.

### SuperClass

MeasurementRelationship

### Associations

from:Measurement [1]	Specifies the measurement at the from-endpoint of the relationship. This property redefines the from-endpoint of MeasurementRelationship.
to:Measurement [1]	Specifies the measurement at the to-endpoint of the relationship. This property redefines the to-endpoint of MeasurementRelationship.

## 42.613.6 DimensionalMeasurement Class (abstract)

The DimensionalMeasurement class represents the results of applying a dimensional measure to an entity. The result is given in terms of the measure's unit. See Figure 13.1.

### SuperClass

Measurement

### Attributes

value:Number [0..1]	Represents the measurement result as a magnitude with respect to the unit of measure.
---------------------	---

**Issue:** SMM12-133 – "From" associations on Dimensional Measure/Measurement are poorly described.

### Associations

gradeFrom:GradeMeasurementRelationship [0..*]	Specifies the relationship instances that define the grade <del>measurements for</del> <b>measurements derived from</b> this measurement. This property subsets the inbound property of Measurement.
rankingFrom:RankingMeasurementRelationship [0..*]	Specifies the relationship instances that define the ranking <del>measurements derived from for</del> <b>measurements derived from</b> this measurement. This property subsets the inbound property of Measurement.
baseMeasurementFrom:BaseMeasurementRelationship [0..*]	Specifies the relationship instances that defines the <del>accumulation collective</del> <b>measurements derived from for</b> this measurement. This property subsets the inbound property of Measurement.
baseMeasurementIFrom:BaseIMeasurementRelationship [0..*]	Specifies the relationship instances that defines the 1 <sup>st</sup> part of the binary

	measurements derived from <del>comparator</del> for this measurement. This property subsets the inbound property of Measurement.
baseMeasurement2From:Base2MeasurementRelationship [0..*]	Specifies the relationship instances that defines the 2nd part of the binary <del>comparator</del> <del>for</del> measurements derived from this measurement. This property subsets the inbound property of Measurement.
rescaleTo:RescaledMeasurementRelationship [0..*]	Specifies the relationship instance that defines the measurement rescaling this measurement. This property subsets the inbound property of Measurement.

## Constraints

```
context DimensionalMeasurement inv:
observedMeasure.measure.oclIsTypeOf(DimensionalMeasure) and
error->isEmpty <> value->isEmpty
```

## 42.713.7 GradeMeasurement Class

**Issue:** SMM12-105 – The wording “base measure(ment)” is ambiguous.

**Issue:** SMM12-150 – SMM is presumptuous about how measurands must relate

The GradeMeasurement class represents the grade ~~found-as defined~~ by GradeMeasure. Its grading scheme maps ~~ped~~ the grade’s ~~underlying~~-base gradeTo.to measurement (possibly rescaled) to the grade’s symbol. ~~Once again,~~ ~~the~~ ~~base-gradeTo.to~~ measurements ~~s typically~~ shares its measurand with this derived grading. See Figure 13.1. ~~But~~ measurands are objects declared in another MOF or UML model and the semantics of that other model (and not SMM) determines how the measurands are related.

## SuperClass

Measurement

**Issue:** SMM12-95 – Replace SMM “string” with UML/MOF “String”.

**Issue:** SMM12-155 – GradeMeasurement value attribute identifies a grade, not a rank

## Attributes

value: <del>string</del> -String [0..1]	Identifies <del>rank-grade</del> as a measurement derived from the base measurement.
isBaseSupplied:Boolean	True if gradeTo is specified (base measurement is supplied).

## Associations

gradeTo:GradeMeasurementRelationship [0..1]	Specifies the relationship instance that defines the measurement graded by this grade. This property subsets the outbound property of Measurement.
baseQuery:Operation [0..1]	Specifies a query that is used to find <del>the</del> base measurement when isBaseSupplied = false (its base

measurement is not supplied).

### Constraints

**Issue: SMM12-150 – SMM is presumptuous about how measurands must relate**

```
context GradeMeasurement inv:  
observedMeasure.measure.ocIsTypeOf(GradeMeasure)  
and error->isEmpty <> value->isEmpty  
and (isBaseSupplied → (measurand = gradeTo.to.measurand  
and gradeTo.to.observedMeasure.measure =  
observedMeasure.measure.gradeTo.to  
and baseQuery->isEmpty))  
and (baseQuery->notEmpty → ( not isBaseSupplied))
```

See Figure 13.1.

### Semantics

Setting isBaseSupplied to false allows the hierarchy of measurements to be elided at any point.

**Issue: SMM12-87 – Relax constraint requiring both boundary points of an Interval.**

If isBaseSupplied holds, then value is one of the symbols found by observedMeasure.measure.interval where gradeTo.to.value is in the interval. A numeric value is in the interval if and only if the ~~it-value~~ is less than the maximum ~~EndPoint~~ when maximumOpen is false, less than or equal to maximum ~~EndPoint~~ when maximumOpen is true, greater than minimum ~~EndPoint~~ when minimumOpen is false, and greater than or equal to minimum ~~EndPoint~~ when minimumOpen is true.

**Issue: SMM12-105 – The wording “base measure(ment)” is ambiguous.**

If isBaseSupplied is false and baseQuery is supplied then the base measurement can be obtained by executing the baseQuery operation. The value of the measurement then is the symbol found by observedMeasure.measure.interval where ~~the~~ base measurement’s value (~~possibly rescaled~~) is in the interval.

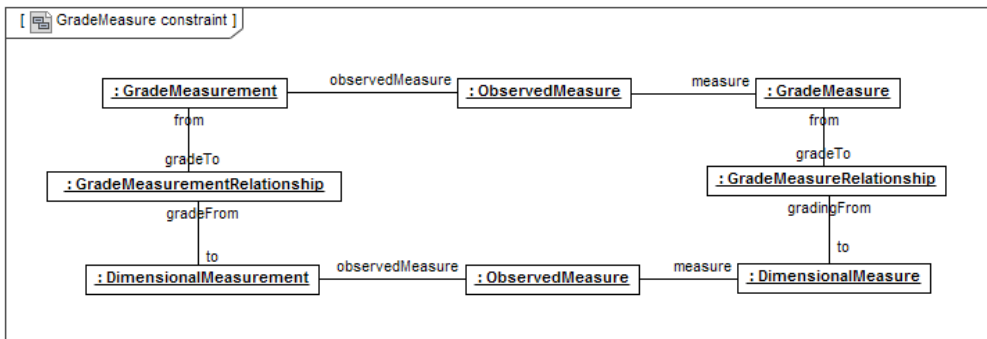

Figure 13.2 - GradeMeasure Constraint

## 12.813.8 GradeMeasurementRelationship Class

GradeMeasurementRelationship is a class representing any relationship of grading between a grade measurement and a dimensional measurement.

**Issue:** SMM12-105 – The wording “base measure(ment)” is ambiguous.

### SuperClass

ScaledBaseMeasurementRelationship

### Associations

from:GradeMeasurement [1]	Specifies the grade measurement at the from-endpoint of the relationship. This property redefines the from-endpoint of MeasurementRelationship.
to:DimensionalMeasurement [1]	Specifies the dimensional measurement at the to-endpoint of the relationship. This property redefines the to-endpoint of MeasurementRelationship.

## 12.913.9 RankingMeasurement Class

**Issue:** SMM12-105 – The wording “base measure(ment)” is ambiguous.

**Issue:** SMM12-150 – SMM is presumptuous about how measurands must relate

The RankingMeasurement class represents the grade ~~found as defined~~ by RankingMeasure. Its ranking scheme maps ~~ped~~ the ranking’s ~~underlying~~ base rankingTo measurement (possibly rescaled) to the ranking’s value. The ~~base~~ rankingTo measurements typically shares its measurand with this derived ranking. See Figure 13.1. ~~But measurands are objects declared in another MOF or UML model and the semantics of that other model (and not SMM) determines how the measurands are related.~~

### SuperClass

Measurement

### Attributes

isBaseSupplied:Boolean	True if rankingTo is specified (base measurement is supplied).
------------------------	--

### Associations

rankingTo:RankingMeasurementRelationship [0..1]	Specifies the relationship instance that defines the measurement ranked by this ranking. This property subsets the outbound property of Measurement.
baseQuery:Operation [0..1]	Specifies a query that is used to find <del>the</del> base measurement when isBaseSupplied = false (its base measurement is not supplied).

### Constraints



---

**Issue: SMM12-150 – SMM is presumptuous about how measurands must relate**

---

```
context RankingMeasurement inv:
observedMeasure.measure.oclIsTypeOf(RankingMeasure)
and (isBaseSupplied →(measurand → rankingTo.to.measurand
and rankingTo.to.observedMeasure.measure =
observedMeasure.measure.rankingTo.to
and baseQuery->isEmpty))
and (baseQuery->notEmpty →( not isBaseSupplied))
```

### Semantics

Setting isBaseSupplied to false allows the hierarchy of measurements to be elided at any point.

---

**Issue: SMM12-87 – Relax constraint requiring both boundary points of an Interval.**

---

If isBaseSupplied holds, then value is found by observedMeasure.measure.interval where rankTo.to.value is in the interval. A numeric value is in the interval if and only if the ~~it-value~~ is less than the maximum~~EndPoint~~ when maximumOpen is false, less than or equal to maximum~~EndPoint~~ when maximumOpen is true, greater than minimum~~EndPoint~~ when minimumOpen is false, and greater than or equal to minimum~~EndPoint~~ when minimumOpen is true.

---

**Issue: SMM12-105 – The wording “base measure(ment)” is ambiguous.**

---

If isBaseSupplied is false and baseQuery is supplied then the base measurement can be obtained by executing the baseQuery operation. The value of the measurement then is found by observedMeasure.measure.interval where ~~the~~ base measurement’s value (~~possibly rescaled~~) is in the interval.

## 42.1013.10 RankingMeasurementRelationship Class

RankingMeasurementRelationship is a class representing any relationship of ranking between a ranking measurement and a dimensional measurement.

---

**Issue: SMM12-105 – The wording “base measure(ment)” is ambiguous.**

---

### SuperClass

ScaledBaseMeasurementRelationship

### Associations

from:RankingMeasurement [1]	Specifies the ranking measurement at the from-endpoint of the relationship. This property redefines the from-endpoint of MeasurementRelationship.
to:DimensionalMeasurement [1]	Specifies the dimensional measurement at the to-endpoint of the relationship. This property redefines the to-endpoint of MeasurementRelationship.

## 13.114.1 General

This class represents measurements found by accumulating a set of base measurements. For example, the number lines of code in application can be determines by accumulating the number lines in its programs.

**Issue: SMM12-95** – Replace SMM “string” with UML/MOF “String”.

**Issue: SMM12-105** – The wording “base measure(ment)” is ambiguous.

**Issue: SMM12-149** – Matching BaseMeasurementRelationship to the correct BaseMeasureRelationship

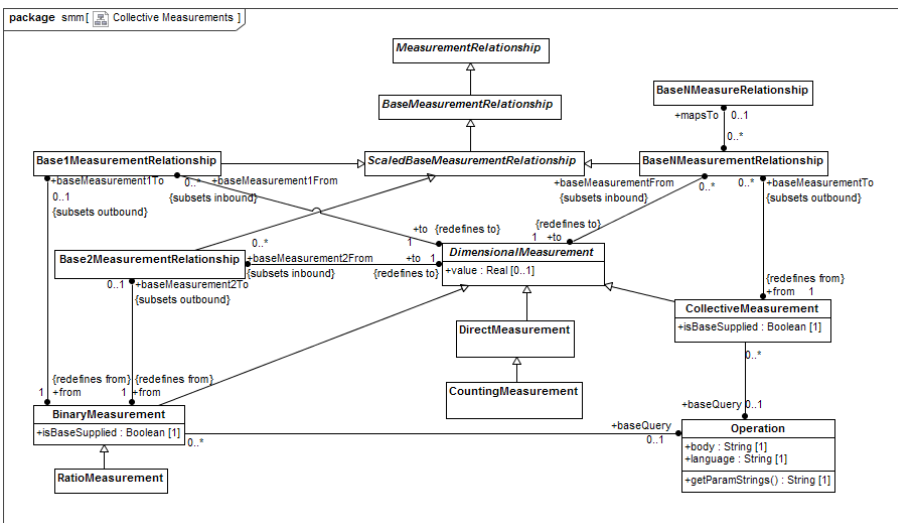
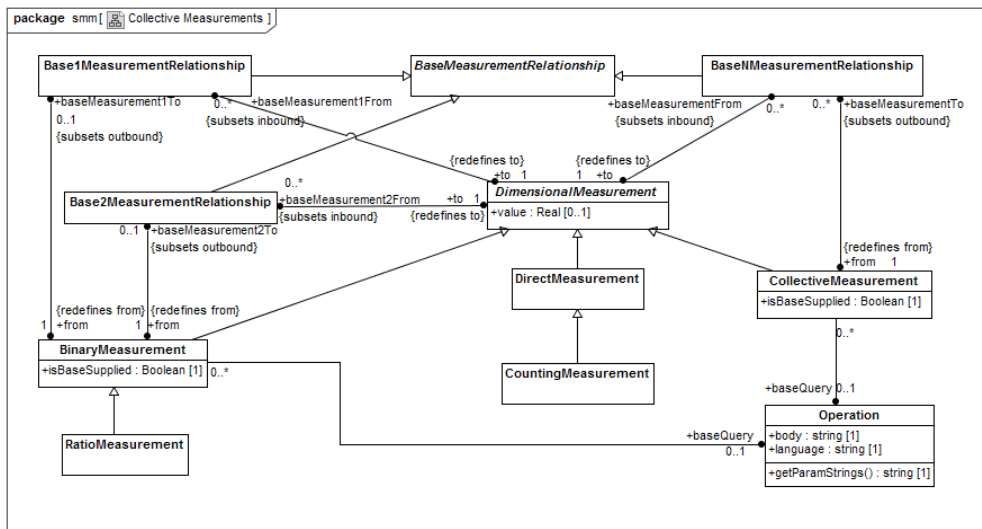

Figure 14.1 - Collective Measurements

## 13.214.2 CollectiveMeasurement Class

The CollectiveMeasurement class represents the results of applying its CollectiveMeasure measure to an entity. See Figure 14.1. In this case, applying the measure is as follows:

1. Apply the base measure to each contained element to obtain a set of base measurements.
2. Apply the n-ary accumulator to the set of base measurements to obtain the measurement of the container.

The results of step 1 are the DimensionalMeasurements associated by base measurement.

### SuperClass

DimensionalMeasurement

### Attributes

isBaseSupplied:Boolean	True if baseMeasurementTo instances are supplied. All are supplied or none is assumed.
------------------------	--

### Associations

baseMeasurementTo: BaseNMeasurementRelationship [0..*]	Specifies the relationship instance that defines the <del>accumulation</del> aggregation for this measurement. This property subsets the outbound property of Measurement.
baseQuery:Operation [0..1]	Specifies a query that is used to find base measurements when isBaseSupplied = false (its base measurements are not supplied).

### Constraints

```
context CollectiveMeasurement inv:
observedMeasure.measure.ocIsInstanceOf(CollectiveMeasure)
and (isBaseSupplied →
    (not baseMeasurementTo->isEmpty and
        and (baseMeasurementTo.to.observedMeasure.measure
            = observedMeasure.measure.baseMeasureTo.to)
        and baseQuery->isEmpty)
and (not isBaseSupplied → baseMeasurementTo->isEmpty)
```

---

#### **Issue: SMM12-149 – Matching BaseMeasurementRelationship to the correct BaseMeasureRelationship**

Each specified `baseMeasurementTo.mapsTo` must be a `BaseNMeasureRelationship` in the collection `observedMeasure.measure.baseMeasureTo` of which the “to” association identifies the `DimensionalMeasure` specified by `baseMeasurementTo.to.observedMeasure.measure`.

### Semantics

Setting `isBaseSupplied` to false allows the hierarchy of measurements to be elided at any point.

If `isBaseSupplied` holds, then value equals the result of applying `observedMeasure.measure.accumulator` to the set of values given by `baseMeasurementTo.to.value`.

If `isBaseSupplied` is false and `baseQuery` is supplied then the base measurement can be obtained by executing the `baseQuery` operation. The value of the measurement then equals the result of applying the `observedMeasure.measure.accumulator` to the found base measurements' values.

---

**Issue:** SMM12-160 – Fix and improve `CollectiveMeasurement` examples.

---

For each `observedMeasure.measure.baseMeasureTo`, there may be multiple `baseMeasurementTo` such that `baseMeasurementTo.to.observedMeasure.measure` is `observedMeasure.measure.baseMeasureTo.to`. For example, in Figure 17.6 the collective measurement sums three measurements (`CostAggregation1-3`) of a single measure (`ActivityCostMeasure`). A more complex example is shown in Figure 11.2 where the collective measure has two base measures and the collective measurement has three base measurements, two from `Measure2` and one from `Measure3`. Each measurement is owned by an `ObservedMeasure` which need not be duplicated. Within an `Observation`, implementers may limit `Argument-less ObservedMeasure` to be at most one per `Measure`.

---

**Issue:** SMM12-91 – Move constraint on the “product” accumulator in `CollectiveMeasure` to `CollectiveMeasurement`.

---

If `observedMeasure.measure.accumulator` is `product`, implementers may choose to enforce unit consistency by restricting `baseMeasurementTo`. An implementer, for example, may require that for each `observedMeasure.measure.baseMeasureTo`, there MUST be exactly one `baseMeasurementTo` such that `baseMeasurementTo.to.observedMeasure.measure` is `observedMeasure.measure.baseMeasureTo.to`.

### 13.314.3 DirectMeasurement Class

The `DirectMeasurement` class represents the measurement results found by of applying the measure's specified operation directly to the measurand. See Figure 14.1.

#### SuperClass

`DimensionalMeasurement`

#### Constraints

```
context DirectMeasurement inv:  
observedMeasure.measure.oclIsTypeOf(DirectMeasure)
```

### 13.414.4 CountingMeasurement Class

---

**Issue:** SMM12-119 – `CountingMeasure` operation should not be confused with `Scope.recognizer`

---

`Counting` forms the basis for multiple metrics. This class consists of a particular subclass of `DirectMeasurement` which is very useful in counting. See Figure 14.1. Its associated measure is a `CountingMeasure` where the specified operation is a ~~recognizer~~ `counter` operation. Therefore, the value of any instance of this class is 1 or 0 depending upon whether or not the measurand is recognized.

#### SuperClass

`DirectMeasurement`

#### Constraints

```
context CountingMeasurement inv:
observedMeasure.measure.oclIsTypeOf(CountingMeasure)
```

## 43-514.5 BinaryMeasurement Class

### SuperClass

DimensionalMeasurement

### Attributes

isBaseSupplied:Boolean	True if both base measurements are supplied.
------------------------	--

**Issue:** SMM12-94 – Replace “accumulate” variants with “combine” concerning binary measures.

### Associations

baseMeasurement1To: Base1MeasurementRelationship[0..1]	Specifies the relationship instance that defines the first base measurement <del>accumulated</del> combined for this measurement. This property subsets the outbound property of Measurement.
baseMeasurement2To: Base2MeasurementRelationship[0..1]	Specifies the relationship instance that defines the second base measurement <del>accumulated</del> combined for this measurement. This property subsets the outbound property of Measurement.
baseQuery:Operation [0..1]	Specifies a query that is used to find base measurements when isBaseSupplied = false (its base measurements are not supplied).

### Constraints

```
context BinaryMeasurement inv:
observedMeasure.measure.oclIsTypeOf(BinaryMeasure) and
isBaseSupplied →
(not baseMeasurement1To.isEmpty and not baseMeasurement2To.isEmpty and
(not baseMeasurement1To.isEmpty →
(baseMeasurement1To.to.observedMeasure.measure =
observedMeasure.measure.baseMeasure1To.to)) and
(not baseMeasurement2To.isEmpty →
(baseMeasurement2To.to.observedMeasure.measure =
observedMeasure.measure.baseMeasure2To.to))) and
baseQuery->isEmpty) and
(not isBaseSupplied→baseMeasurement1To->isEmpty and baseMeasurement2To->isEmpty)
```

### Semantics

Setting isBaseSupplied to false allows the hierarchy of measurements to be elided at any point.

If isBaseSupplied holds, then value equals the result of applying observedMeasure.measure.functor to baseMeasurement1To.to.value and baseMeasurement2To.to.value.

If `isBaseSupplied` is false and `baseQuery` is supplied then the base measurement can be obtained by executing the `baseQuery` operation. The value of the measurement then equals the result of applying `observedMeasure.measure.functor` to the found base measurements' values.

## 13.614.6 RatioMeasurement Class

The `RatioMeasurement` class affords evaluations of a `RatioMeasure` of two evaluations of different dimensional measures. See Figure 14.1. The measure associated with the dividend has its unit of measure in common with the measure associated with the divisor.

### SuperClass

`BinaryMeasurement`

### Constraints

```
context RatioMeasurement inv:  
observedMeasure.measure.ocIsTypeOf(RatioMeasure) and  
isBaseSupplied →  
  (value = baseMeasurement1To.to.value / baseMeasurement2To.to.value)
```

## 13.714.7 BaseMeasurementRelationship Class (abstract)

`BaseMeasurementRelationship` is a class representing relationship of hierarchy between a derived measurement and a base dimensional measurement.

### SuperClass

`MeasurementRelationship`

---

**Issue:** SMM12-105 – The wording “base measure(ment)” is ambiguous.

---

## 14.8 ScaledBaseMeasurementRelationship Class

`ScaledBaseMeasurementRelationship` is a class representing relationship of hierarchy between a derived measurement and its possibly rescaled base measurements.

### SuperClass

`BaseMeasurementRelationship`

---

**Issue:** SMM12-105 – The wording “base measure(ment)” is ambiguous.

---

## 13.814.9 BaseNMeasurementRelationship Class

`BaseNMeasurementRelationship` is a class representing relationship of hierarchy between a collective measurement and a dimensional measurement.

### SuperClass

ScaledBaseMeasurementRelationship

---

**Issue:** SMM12-149 – Matching BaseMeasurementRelationship to the correct BaseMeasureRelationship

---

### Associations

from:CollectiveMeasurement [1]	Specifies the collective measurement at the from-endpoint of the relationship. This property redefines the from-endpoint of MeasurementRelationship.
to: DimensionalMeasurement [1]	Specifies the dimensional measurement at the to-endpoint of the relationship. This property redefines the to-endpoint of MeasurementRelationship.
mapsTo:BaseNMeasureRelationship[0..1]	Identifies a BaseNMeasureRelationship of from.observed measure.measure.baseMeasureTo with which this BaseNMeasurementRelationship corresponds.

### Semantics

CollectiveMeasures may have multiple baseMeasureTo associations where the “to” associations connect to the same input DimensionalMeasure. The BaseMeasureRelationships may have different rescaleMeasures.

For CollectiveMeasurements of such a CollectiveMeasure, it’s useful to map the baseMeasurementTo (a BaseNMeasurementRelationship) to the corresponding baseMeasureTo (a BaseNMeasureRelationship) of the CollectiveMeasure. The mapsTo association provides this mapping. MapsTo eliminates the need for complex queries to resolve potential ambiguities in mapping baseMeasurementTo to baseMeasureTo.

---

**Issue:** SMM12-105 – The wording “base measure(ment)” is ambiguous.

---

### 43.914.10 Base1MeasurementRelationship Class

Base1MeasurementRelationship is a class representing relationship of hierarchy between a binary measurement and a dimensional measurement.

### SuperClass

ScaledBaseMeasurementRelationship

### Associations

from:BinaryMeasurement [1]	Specifies the binary measurement at the from-endpoint of the relationship. This property redefines the from-endpoint of MeasurementRelationship.
to: DimensionalMeasurement [1]	Specifies the dimensional measurement at the to-endpoint of the relationship. This property redefines the to-endpoint of MeasurementRelationship.

---

**Issue:** SMM12-105 – The wording “base measure(ment)” is ambiguous.

---

### 43.1014.11 Base2MeasurementRelationship Class

Base2MeasurementRelationship is a class representing relationship of hierarchy between a binary measurement and a dimensional measurement.

## SuperClass

| ScaledBaseMeasurementRelationship

## Associations

from: BinaryMeasurement [1]	Specifies the binary measurement at the from-endpoint of the relationship. This property redefines the from-endpoint of MeasurementRelationship.
to: DimensionalMeasurement [1]	Specifies the dimensional measurement at the to-endpoint of the relationship. This property redefines the to-endpoint of MeasurementRelationship.



## 1415          **Named and Rescaled Measurements**

### 14.115.1    **General**

Measurement is in terms of its unit of measure as specified under its associated DimensionalMeasure. That is, the measurement is a multiple of its unit of measure where value determines the multiple.

---

**Issue:** SMM12-95 – Replace SMM “string” with UML/MOF “String”.

**Issue:** SMM12-105 – The wording “base measure(ment)” is ambiguous.

---

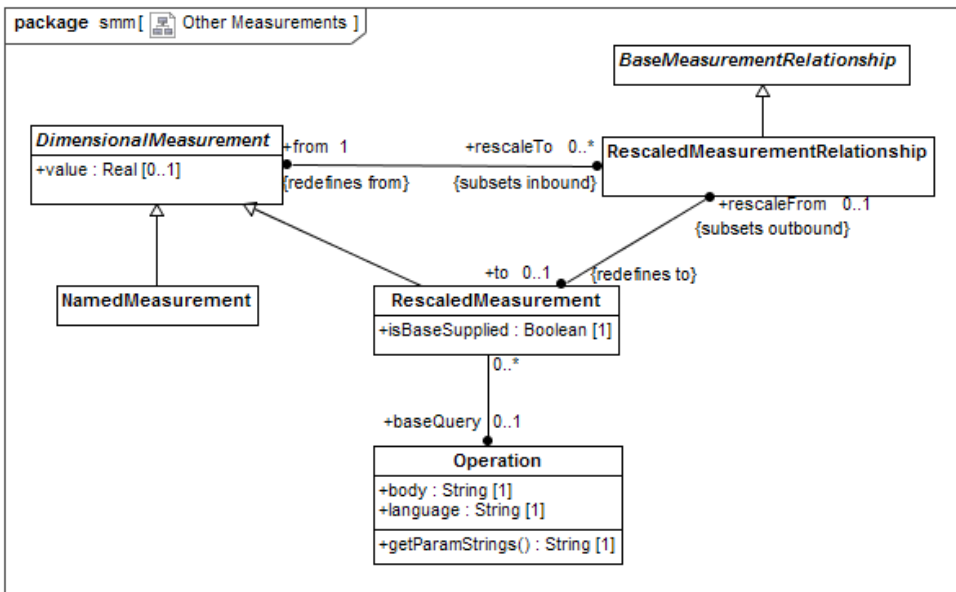
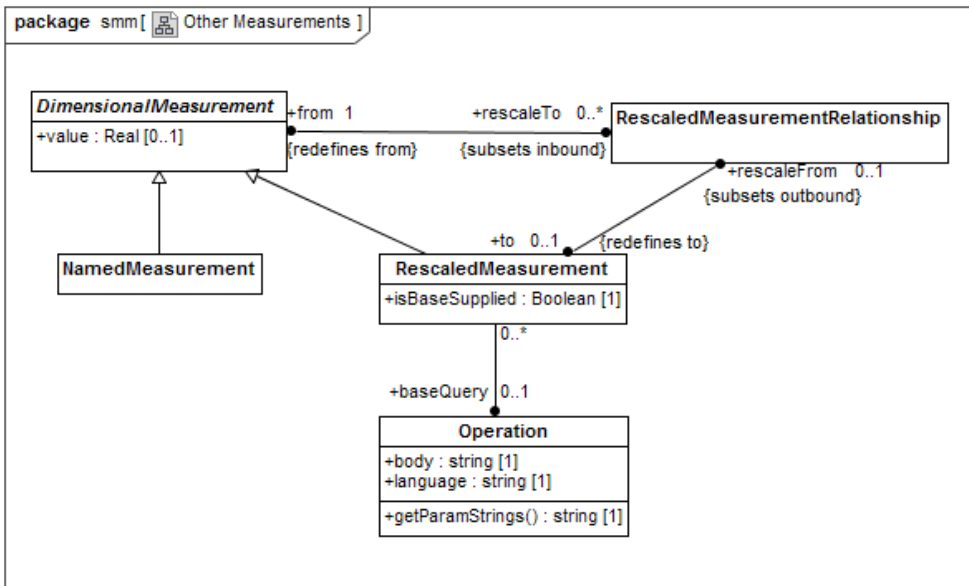

Figure 15.1 - Named and Rescaled Measurements

## 14.215.2 NamedMeasurement Class

The NamedMeasurement class represents the measurement results of applying to the Measurand measurement processes which are generally known and identifiable by name. See Figure 15.1.

## SuperClass

**Issue:** SMM12-140 – Wrong superclasses for NamedMeasurement and RescaledMeasurement

DimensionalMeasurement

## Constraints

```
context NamedMeasurement inv:  
observedMeasure.measure.oclIsTypeOf(NamedMeasure).
```

**Issue:** SMM12-150 – SMM is presumptuous about how measurands must relate

**Issue:** SMM12-151 – Description of RescaledMeasurement class is too restrictive

## 4.3.15.3 RescaledMeasurement Class

The RescaledMeasurement class represents the measurement results of applying to ~~the~~ a base measurement the operation or multiplier and offset as specified by the Measure to rescale the measurement. The RescaledMeasurement can have a different unit of measure. ~~That is, given a one measurement of the measurand with respect to one unit of measure, we obtain a second measurement of the measurand with respect to a different unit of measure.~~ See Figure 15.1. We anticipate that the measurands of the rescaling and its base measurement are identical. Measurands, however, are objects declared in another MOF or UML model and the semantics of that other model (and not SMM) determines how the measurands are related.

~~Measure is a RescaledMeasure.~~

## SuperClass

**Issue:** SMM12-140 – Wrong superclasses for NamedMeasurement and RescaledMeasurement

DimensionalMeasurement

## Attributes

isBaseSupplied:Boolean	True if the base measurement is supplied.
------------------------	---

## Associations

rescaleFrom:RescaledMeasurementRelationship [0..1]	Specifies the relationship instance that defines the measurement rescaled by this rescaled measurement. This property subsets the outbound property of Measurement.
baseQuery:Operation [0..1]	Specifies a query that is used to find the base measurement when isBaseSupplied = false (its base measurement is not supplied).

## Constraints

```
context RescaledMeasurement inv:  
observedMeasure.measure.oclIsTypeOf(RescaledMeasure)
```

```

and (isBaseSupplied → not rescaleFrom->isEmpty and
    (rescaleFrom.from.observedMeasure.measure
    = observedMeasure.measure.rescaleFrom.from)
    and baseQuery->isEmpty)
and (not isBaseSupplied → rescaleFrom->isEmpty)

```

## Semantics

Setting isBaseSupplied to false allows the hierarchy of measurements to be elided at any point.

If isBaseSupplied is true then value equals result of applying observedMeasure.measure.operation to the rescaleFrom.from.value.

If isBaseSupplied is false and baseQuery is supplied, then the base measurement can be obtained by executing the baseQuery operation. The value of the measurement then equals the result of applying observedMeasure.measure.operation to the found base measurement's values.

### 44.415.4 RescaledMeasurementRelationship Class

RescaledMeasurementRelationship is a class representing relationship of measurement rescaling between a rescaled measurement and a dimensional measurement.

---

**Issue: SMM12-105 – The wording “base measure(ment)” is ambiguous.**

---

#### SuperClass

BaseMeasurementRelationship

#### Associations

from: DimensionalMeasurement [1]	Specifies the dimensional measurement at the from-endpoint of the relationship. This property redefines the from-endpoint of MeasurementRelationship.
to: RescaledMeasurement [1]	Specifies the rescaled measurement at the to-endpoint of the relationship. This property redefines the to-endpoint of MeasurementRelationship.

# 1516 Observations

## 15.116.1 General

Measurements are sometimes repeated. An old carpentry rule is measure twice, cut once.

To distinguish these multiple measurements, the observation and scope class can represent contextual information such as the time of the measurement and the identification of the measurement tool and the artifacts that are under measurement.

**Issue:** SMM12-95 – Replace SMM “string” with UML/MOF “String”.

**Issue:** SMM12-92 – Inconsistent handling of inherited attributes.

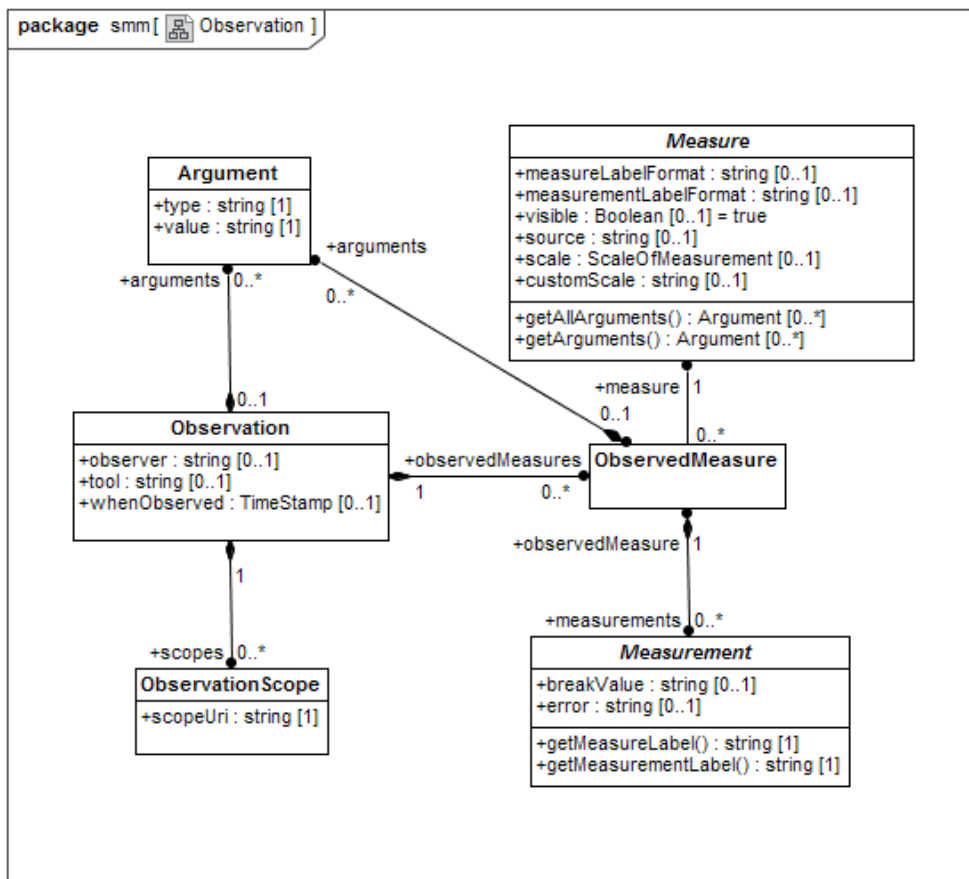

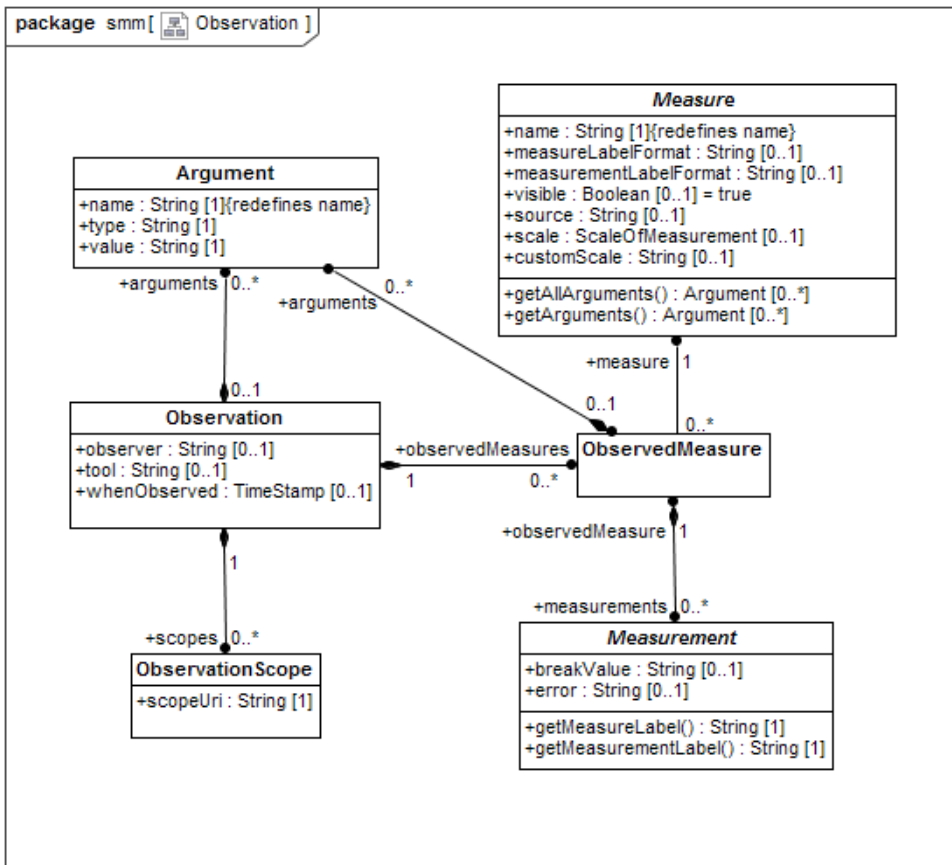

Figure 16.1 - Observations

## 15.216.2 Observation Class

This class represents some of the contextual information which may be unique to this measurement such as date, measurer and tool used. See Figure 16.1.

### SuperClass

SmmElement

**Issue:** SMM12-95 – Replace SMM “string” with UML/MOF “String”.

### Attributes

whenObserved:TimeStamp[0..1]	Identifies the “moment” when the measurement was taken.
observer: <del>string</del> String [0..1]	Identifies measurer.
tool: <del>string</del> String [0..1]	Identifies tool used in measurement.

## Associations

observedMeasures:ObservedMeasure [0..*]	The set of all ObservedMeasure owned by the observation.
requestedMeasures:AbstractMeasureElement [0..*]	Specifies the measures or their category that are part of the observation request. This association is optional and can be used by a builder to know what to include in a specific observation.
scopes:ObservationScope [0..*]	Specifies the scopes of the observation, i.e. the models or model portions that are the subject of the Observation
arguments:Argument [0..*]	Specifies the arguments of the observation.

## Constraints

```
context Observation inv:
requestedMeasures.oclIsTypeOf(MeasureCategory) or
requestedMeasures.oclIsTypeOf(CategoryRelationship) or
requestedMeasures.oclIsTypeOf(Measure)
```

### 15.316.3 ObservationScope Class

This class represents the model(s) or sub model that are the subject of the related observation. This information can be used initially by builders to understand which model to gather measurements from, later by anyone wishing to recreate a new observation of the same artifacts. See Figure 16.1.

## SuperClass

SmmElement

---

**Issue:** SMM12-95 – Replace SMM “string” with UML/MOF “String”.

**Issue:** SMM12-134 – ObservationScope Class semantics sub-clause is mostly non-normative

---

## Attributes

scopeUri: <del>string</del> String [1]	Uri that identifies model(s) or model fragment.  The scopeUri represents specific schemes following the <a href="#">RFC 2396: Uniform Resource Identifiers (URI): Generic Syntax</a> . As a hierarchical URI, the scopeUri supports all features associated with such URI, including both absolute and relative addressing. The starting point for the resolution of relative addressing should match generally accepted rules, but this specification doesn't dictate any such details.
--	--

---

**Issue:** SMM12-134 – ObservationScope Class semantics sub-clause is mostly non-normative

---

## Semantics (Non-Normative)

The scopeUri represents specific schemes following the [RFC 2396: Uniform Resource Identifiers \(URI\): Generic Syntax](#). As a hierarchical URI, the scopeUri supports all features associated with such URI, including both absolute and relative addressing. The starting point for the resolution of relative addressing should match generally accepted

~~rules, but this specification doesn't dictate any such details.~~

To quote the URI syntax:

At the highest level a URI reference (hereinafter simply "URI") in string form has the syntax

```
[scheme:]scheme-specific-part[#fragment]
```

The scopeUri should inherently accept and understand the following 2 schemes: *mof* and *ecore*, respectively representing models expressed as MOF and Ecore (Eclipse EMF model variant of MOF).

Our scheme-specific-part complies with the definition of hierarchical URI and as such it has the following syntax:

```
[//authority][path][?query]
```

The general form of a scope uri is then:

mof://kdm.example.com/projectName/kdmName	Uri for a specific MOF KDM model.
ecore://astm.example.com/pathToWherever/longPath/modelName	Uri for a specific Ecore ASTM model

A more advanced form of the URI for our schemes is made to support the query part of the URI in order to specify portion of models and also to specify models in paths that represent folders or collections.

The query part of the scopeUri follows the general form of key=value separated by ampersand (&). The following keys are defined by our schemes:

Model	Regex based pattern representing the name of model or models that should be matched in the path
Recursive	True if the search for models matching the model pattern should also recursively descend the hierarchical path structure rooted at the path specified in the URI. Default is false.
queryType	Type of query to use in select. "OCL" (default) or "XQuery".
Select	Query into selected model(s) that represent a selection of a subset or portion of the entire model that will be used as the scope of performing measurements. For example this could represent a segment in a KDM that is related to a specific application.

The general form of a scope uri is then:

mof://kdm.example.com/projectName?model=a?rt*&recursive=true	Uri for all MOF models with name matching a?rt* located in projectName or under.
ecore://kdm.example.com/path/?queryType=Xquery&select=/Segment[@name="default"]/ Segment[@name="myApp"]	Uri for a specific Ecore KDM model segment representing a particular application segment.

## 15.416.4 ObservedMeasure Class

This class represents association between observations and the measures that make up such observation. This class also serves to hold the list of measurements characterized by the related measure that are part of a given observation.

**Issue: SMM12-150 – SMM is presumptuous about how measurands must relate**

Both Observation and ObservedMeasure can have associated Argument. ~~Different measurements-~~ Within a single observation ~~of a same measurand using the a same~~ measure can be applied to a measurand with different arguments ~~resulting in different measurements~~. This is a practical way to handle operation parameters, both stochastic parameters and parameters in general. Arguments specified ~~in~~ in a measure's containing ObservedMeasure take precedence over those specified in the ObservedMeasure's containing Observation.

### SuperClass

SmmElement



## Associations

measurements:Measurement [0..*]	The set of all Measurement owned by the observed measure.
measure:Measure [1]	The measure that is being observed.
arguments:Argument [0..*]	Specifies the arguments of the observation measure.

## 45-516.5 Argument Class

This class represents some of the variable arguments or parameters that are being passed to the measures that have Operations that make use of replaceable parameters.

### SuperClass

SmmElement

---

**Issue:** SMM12-95 – Replace SMM “string” with UML/MOF “String”.

**Issue:** SMM12-92 – Inconsistent handling of inherited attributes.

---

### Attributes

name: <del>string-String</del> [1..1]	Specifies the name of the argument ( <del>inherited</del> ). This property redefines the name of SmmElement.
type: <del>string-String</del> [1]	Specifies the type of the argument. See semantic section for detailed information.
value: <del>string-String</del> [1]	The value of the argument, expressed in a “typesafe” fashion.

## Associations

None

## Semantics

The type attribute represents the type of the argument being passed. The accepted types are the basic types that are defined in OCL, as this is the main operation language supported. Those types are, as defined in section 7.1 of the OCL 2.1 specification: Boolean, Integer, Real and string.

The above supported types are very limited. For example there is no direct support for Date or DateTime. The implementation of additional types is left to the implementers. As a suggestion (not normative), implementers should try to use OCLOperation helper functions in order to facilitate hiding the implementation and make their implementation shareable and portable.

For all accepted types, the value attribute is a string whose content directly matches what is expected by the Operation language, so that it can be transferred verbatim into the Operation body during the parameter replacement. Implementer specific types can define their own value format if needed.

## 4617 Example Measures (Non-normative)

### 46.117.1 General

This Clause provides non-normative examples that demonstrate how SMM can be used. Both software-related and business-related examples are provided.

Each measure is defined using the classes of the SMM.

### 46.217.2 Common Patterns

#### Historic and Trend Data

SMM does not model tracking or trend data directly. Linking versions of objects through a software evolution poses a concern in modeling software evolution even if measures are never taken. When the measurand's model provides the linkage (e.g. an "EvolvesTo"/"EvolvesFrom" relationship), then a measurement of an original artifact could be traced to its newer versions and to their measurements if available. The diagram below (Figure 17.1) is overly simplistic, but hopefully conveys the gist of such tracing. The central point is that the "evolves" path is between instances of the base model. The measures of the evolving artifacts can be gathered or compared only if the linkage between the artifacts is captured and maintained through the modeling of the system development and modification.

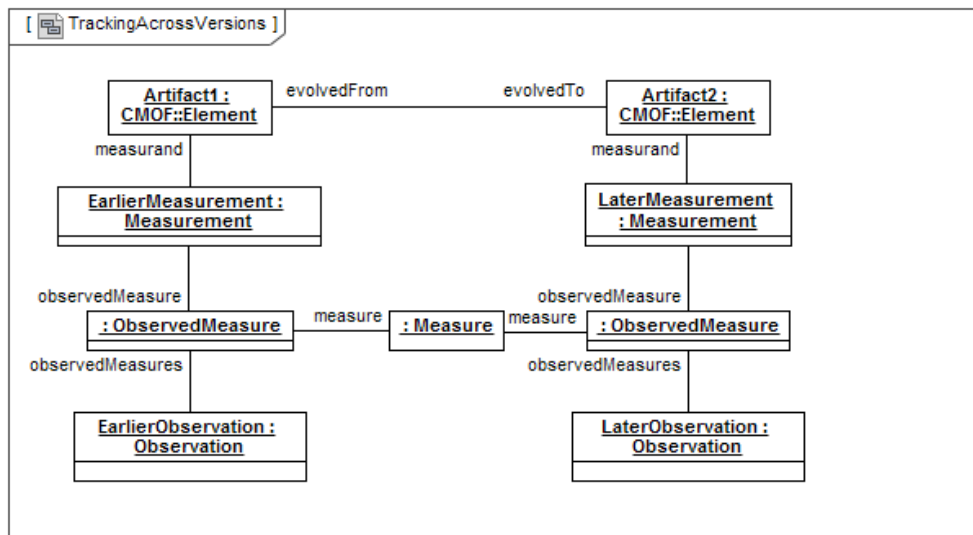

Figure 17.1 - Tracking Measurements across Versions

#### Inaccuracy

Inaccuracy of a measurement is the amount by which the measurement is in error. That is, we may model inaccuracy as measure if we first model a measure which is assumed to be true. Inaccuracy of a measurement is then just the difference between the measurement and a "true" measurement of the same entity.

In SMM inaccuracy is representable by measures that characterize inaccuracy. The measures are comparable elevation of measurements evaluated by the difference between the measurement and the truest (at least accepted as

such) measurement of that entity for that trait.

Given two measures which characterize the same trait and share the same scope, then inaccuracy can be modeled as a binary measure expressing the difference taken over the two measures.

In the demonstration below (Figure 17.2) a category collects measures that are applicable to Class1 and characterize Trait1. The category identifies the “truest” measure by the goldStandard relationship and identifies an appropriate inaccuracy measure for Measure1 by the InaccuracyMeasure relationship.

A Characteristic may have a measure that is designated as the best or truest measure of the attribute. That measure may be associated as the attribute’s gold standard. Such a designation allows for the representation of inaccuracy for each of the attribute’s measures as the difference between the measure and the gold standard.

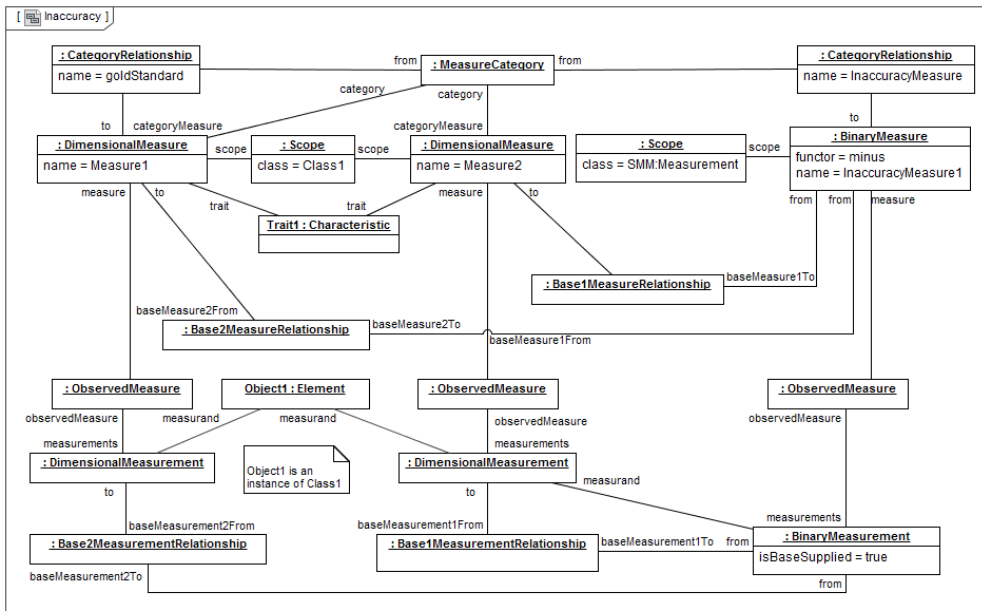

Figure 17.2 - Inaccuracy Demonstration

## Uncertainty

The uncertainty of a measure provides a margin of error which indicates a range which likely encloses the true value. A measure library designer may capture the uncertainty in SMM using the pattern demonstrated in Figure 17.3. An instance of MeasureRelationship (named UncertaintyMeasureOf) connects ExampleMeasure to a measure of its uncertainty. An instance of MeasurementRelationship (named UncertaintyMeasurementOf) connects a measurement of ExampleMeasure to a measurement of its uncertainty measure.

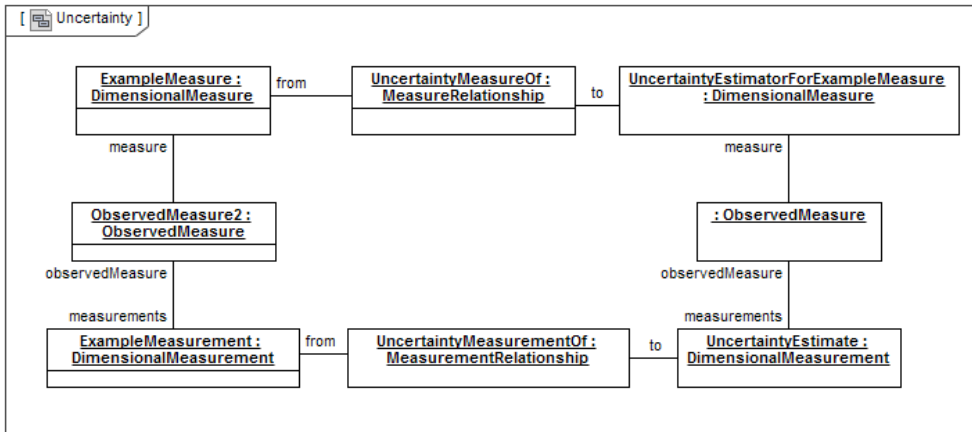

Figure 17.3 - Uncertainty Demonstration

## 16.317.3 Business Measures

### Profit Measure

A profit is calculated from cost and revenue. Cost is multiplied by -1, when aggregated to profit. Revenue currency is converted from EUR to USD, when aggregated to profit. Cost might itself be aggregated from underlying cost components (not in this diagram).

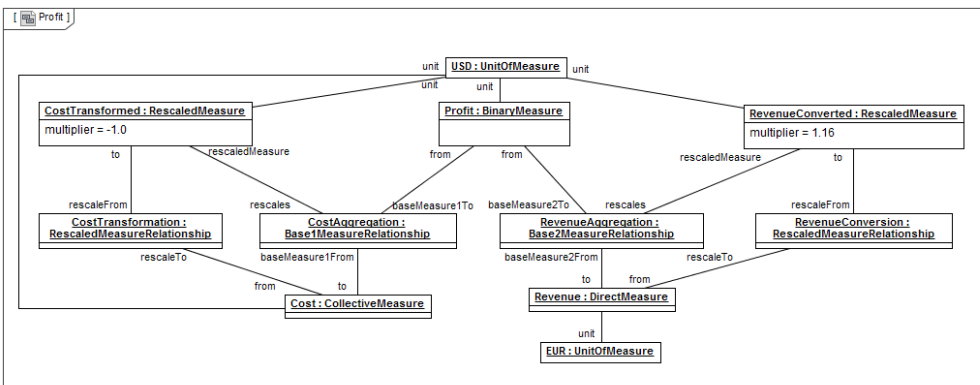

Figure 17.4 - Profit Measure

## Customer Satisfaction Measure

---

**Issue:** SMM12-87 – Relax constraint requiring both boundary points of an Interval.

---

DeliveryTime is measured in Days. CustomerSatisfaction is measured based on grading of DeliveryTime.  
| Consequently, GradeInterval ~~boundaries~~ endpoints are expressed in Days.

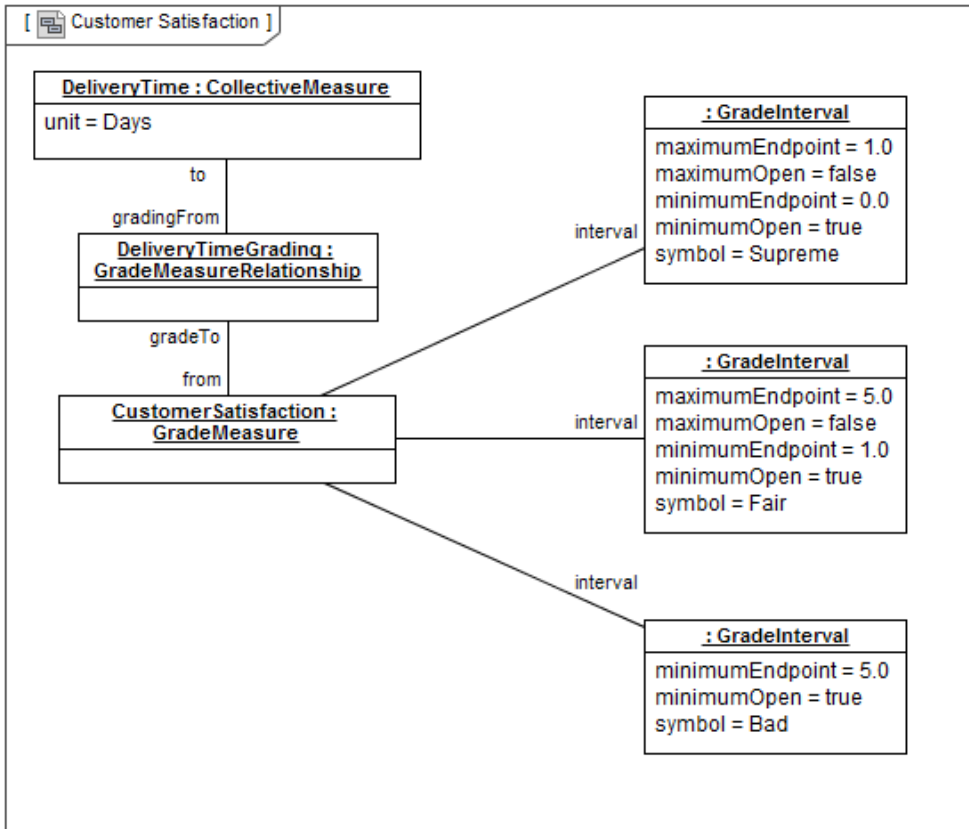

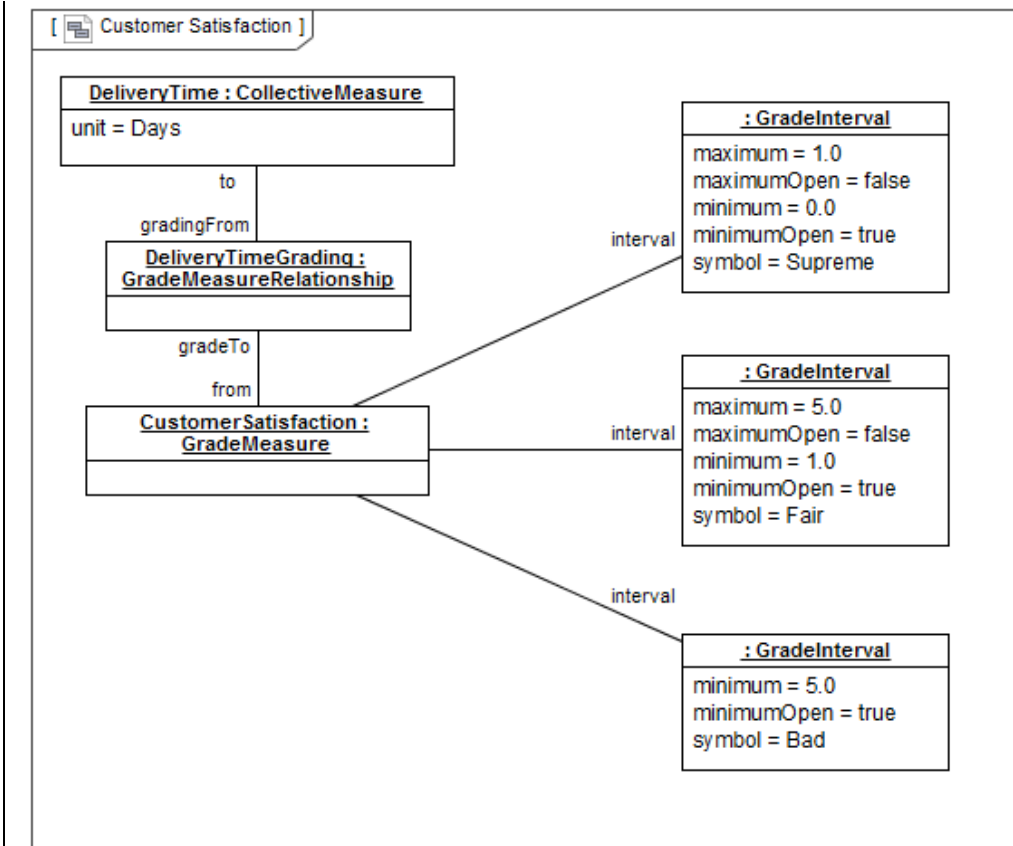

Figure 17.5 - Customer Satisfaction Measure

### Value Stream Cost Measure

Cost of multiple Activities in the Value Stream is measured based on the same Measure. Resulting Measurements are aggregated to a CollectiveMeasurement for the Value Stream.

---

**Issue:** SMM12-160 – Fix and improve CollectiveMeasurement examples.

---



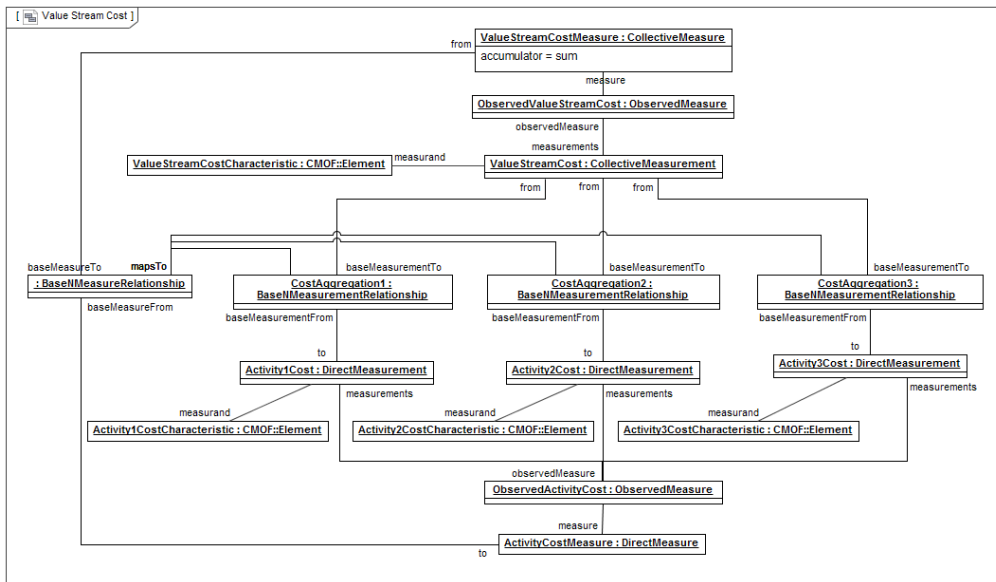
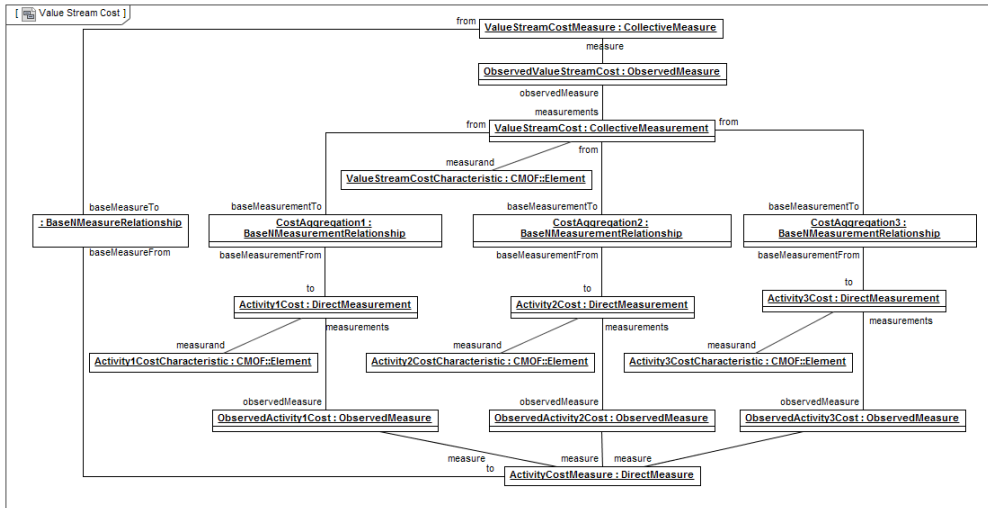

Figure 17.6 - Value Stream Cost Measure

### Cost Measure with recursion

Cost is measured by a **CollectiveMeasure**, which aggregates from a **DirectMeasure** of cost, as well as from the same **CollectiveMeasure** of cost. This way cost can be aggregated recursively.

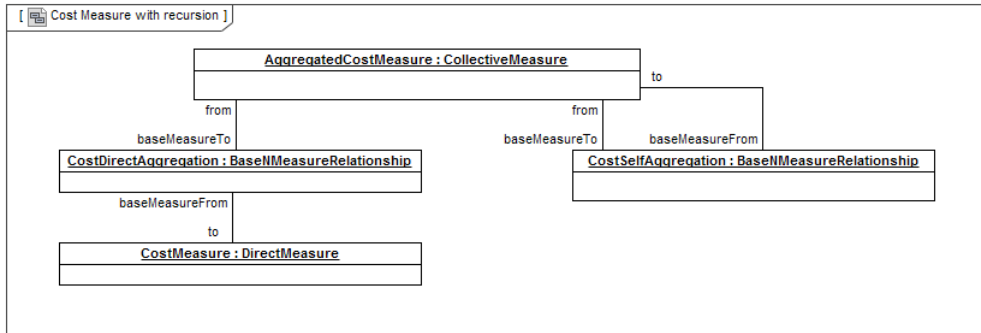

Figure 17.7 - Cost Measure with Recursion

## 16.417.4 Software Measures

### Software Engineering Institute (SEI) Maintainability Index

Maintainability for a collection of code modules (e.g. programs) is calculated by the formula:

$$171 - 5.2(\ln(\text{aveV})) - 0.23(\text{aveV}(g')) - 16.2(\ln(\text{aveLOC})) + 50(\sin(\sqrt{2.4}(\text{perCM})))$$

where aveV is the average Halstead volume, aveV(g') is the average Cyclomatic complexity, aveLOC is the lines of code count and perCM is the percentage of comments in the modules.

Each of the averages is a RatioMeasure of the respective metric for modules over the count of modules. perCM is a RatioMeasure of line count of comments over the total line count of a module.

Each resulting metric is rescaled to share the same unit of measure, namely maintainability index points.

aveV rescaled	$50 - 5.2(\ln(\text{aveV}))$
aveV(g') rescaled	$50 - 0.23(\text{aveV}(g'))$
aveLOC rescaled	$21 - \ln(\text{aveLOC})$
perCM rescaled	$50(\sin(\sqrt{2.4}(\text{perCM})))$

The SEI index is then a CollectiveMeasure for a module of the above four rescaling with addition as the aggregator.

The referenced software artifacts are modeled using the Knowledge Discovery Metamodel (KDM) unless otherwise noted.

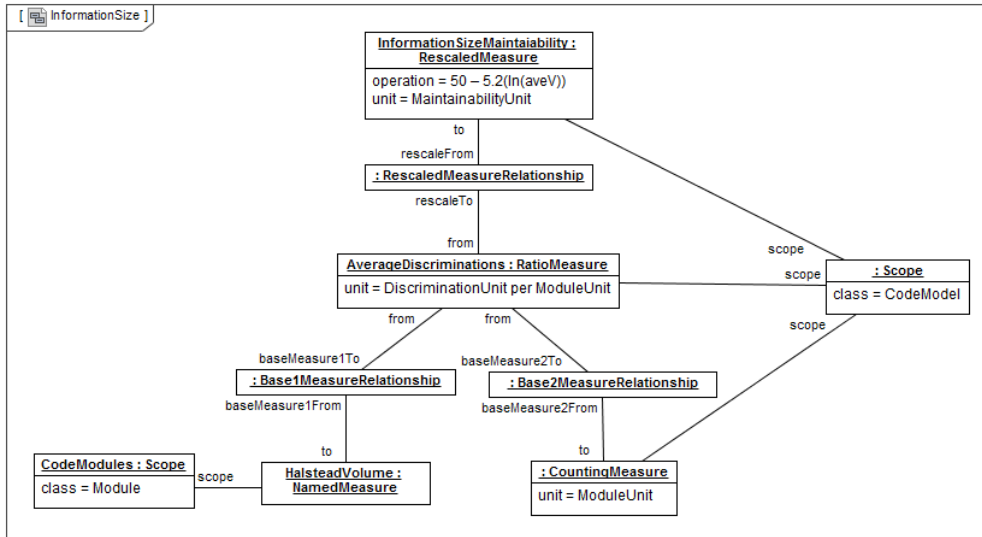

Figure 17.8 - Conversion of Information Size to Maintainability

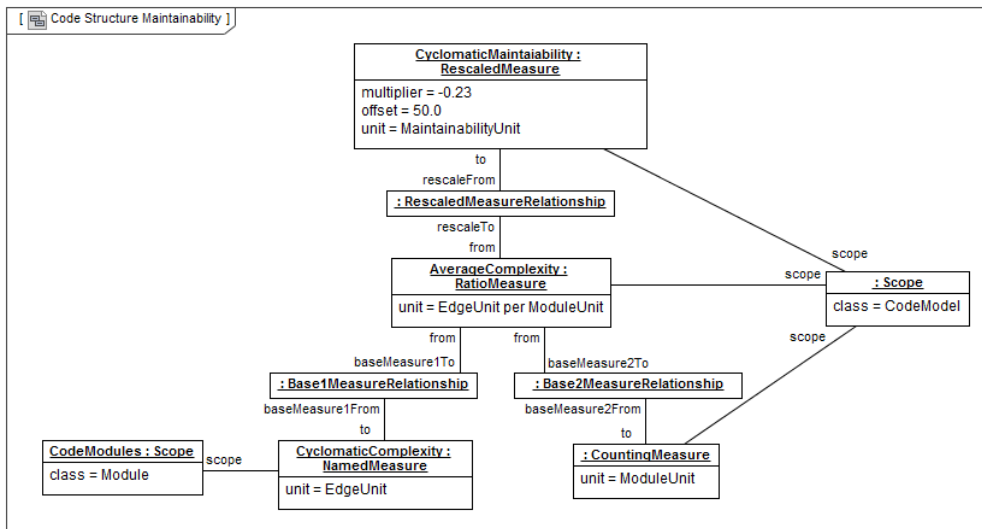

Figure 17.9 - Conversion of McCabe Cyclomatic to Maintainability

A line of code is any line of program text that is not a comment or a blank line, regardless of the number of statements or fragments of statements on the line. This specifically includes all lines containing program headers, declarations, and executable and non-executable statements<sup>2</sup> Lines of code here means fully expanded lines of code including copy books, includes and comments.

<sup>2</sup> See S. Conte, H. Dunsmore, V. Shen, *Software Engineering Metrics and Models*, Benjamin/Cummings, Menlo Park, CA.

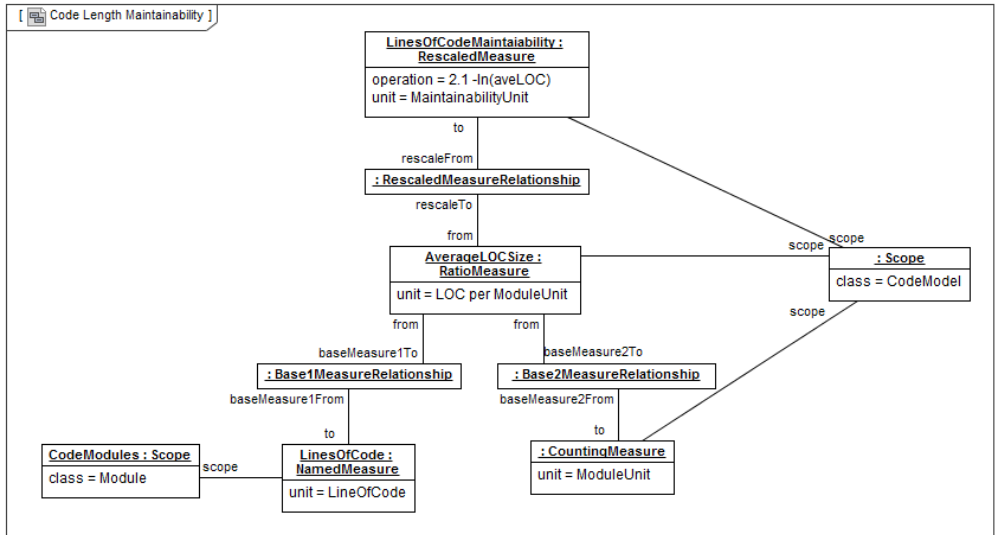

Figure 17.10 - Conversion of LOC to Maintainability

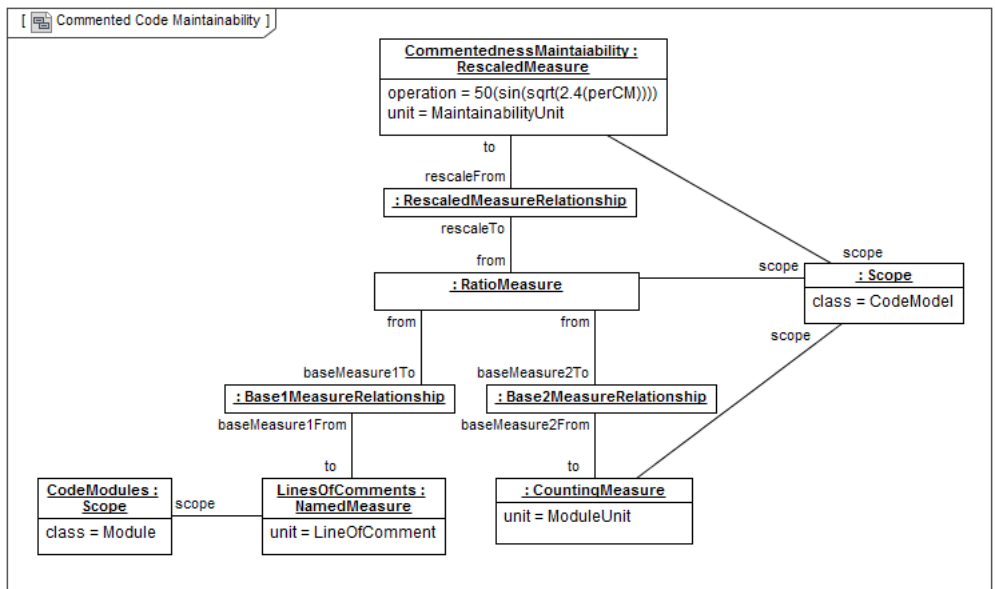

Figure 17.11 - Conversion of Comment Count to Maintainability

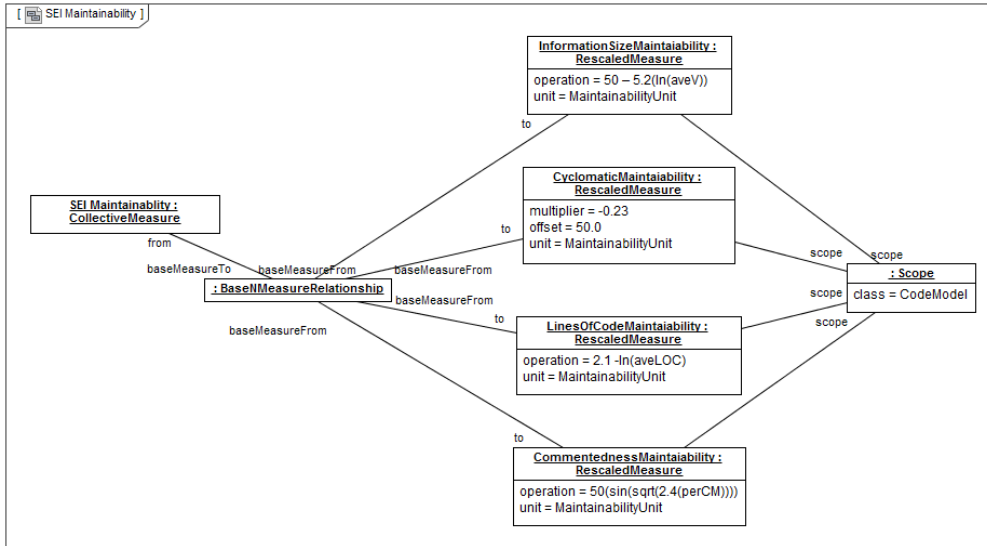

Figure 17.12 - SEI Maintainability Demonstration