

---

# Notification/JMS Interworking Specification

---

This OMG document replaces the submission document (telecom/03-03-01). It is an OMG Final Adopted Specification and is currently in the finalization phase. Comments on the content of this document are welcomed, and should be directed to *issues@omg.org* by June 30, 2003.

You may view the pending issues for this specification from the OMG revision issues web page <http://cgi.omg.org/issues/>; however, at the time of this writing there were no pending issues.

The FTF Recommendation and Report for this specification will be published on September 26, 2003. If you are reading this after that date, please download the available specification from the OMG Specifications Catalog.

---

---

# Notification/Java Message Service (JMS) Interworking Specification

---

**June 2003**  
**Final Adopted Specification**  
**dtc/03-06-01**



**An Adopted Specification of the Object Management Group, Inc.**

---

---

Copyright © 2001, Alcatel  
Copyright © 2001, Fujitsu Limited  
Copyright © 2001, IONA  
Copyright © 2001, Prismtech

## USE OF SPECIFICATION - TERMS, CONDITIONS & NOTICES

The material in this document details an Object Management Group specification in accordance with the terms, conditions and notices set forth below. This document does not represent a commitment to implement any portion of this specification in any company's products. The information contained in this document is subject to change without notice.

### LICENSES

The companies listed above have granted to the Object Management Group, Inc. (OMG) a nonexclusive, royalty-free, paid up, worldwide license to copy and distribute this document and to modify this document and distribute copies of the modified version. Each of the copyright holders listed above has agreed that no person shall be deemed to have infringed the copyright in the included material of any such copyright holder by reason of having used the specification set forth herein or having conformed any computer software to the specification.

Subject to all of the terms and conditions below, the owners of the copyright in this specification hereby grant you a fully-paid up, non-exclusive, nontransferable, perpetual, worldwide license (without the right to sublicense), to use this specification to create and distribute software and special purpose specifications that are based upon this specification, and to use, copy, and distribute this specification as provided under the Copyright Act; provided that: (1) both the copyright notice identified above and this permission notice appear on any copies of this specification; (2) the use of the specifications is for informational purposes and will not be copied or posted on any network computer or broadcast in any media and will not be otherwise resold or transferred for commercial purposes; and (3) no modifications are made to this specification. This limited permission automatically terminates without notice if you breach any of these terms or conditions. Upon termination, you will destroy immediately any copies of the specifications in your possession or control.

### PATENTS

The attention of adopters is directed to the possibility that compliance with or adoption of OMG specifications may require use of an invention covered by patent rights. OMG shall not be responsible for identifying patents for which a license may be required by any OMG specification, or for conducting legal inquiries into the legal validity or scope of those patents that are brought to its attention. OMG specifications are prospective and advisory only. Prospective users are responsible for protecting themselves against liability for infringement of patents.

### GENERAL USE RESTRICTIONS

Any unauthorized use of this specification may violate copyright laws, trademark laws, and communications regulations and statutes. This document contains information which is protected by copyright. All Rights Reserved. No part of this work covered by copyright herein may be reproduced or used in any form or by any means--graphic, electronic, or mechanical, including photocopying, recording, taping, or information storage and retrieval systems--without permission of the copyright owner.

### DISCLAIMER OF WARRANTY

WHILE THIS PUBLICATION IS BELIEVED TO BE ACCURATE, IT IS PROVIDED "AS IS" AND MAY CONTAIN ERRORS OR MISPRINTS. THE OBJECT MANAGEMENT GROUP AND THE COMPANIES LISTED ABOVE

---

MAKE NO WARRANTY OF ANY KIND, EXPRESS OR IMPLIED, WITH REGARD TO THIS PUBLICATION, INCLUDING BUT NOT LIMITED TO ANY WARRANTY OF TITLE OR OWNERSHIP, IMPLIED WARRANTY OF MERCHANTABILITY OR WARRANTY OF FITNESS FOR A PARTICULAR PURPOSE OR USE. IN NO EVENT SHALL THE OBJECT MANAGEMENT GROUP OR ANY OF THE COMPANIES LISTED ABOVE BE LIABLE FOR ERRORS CONTAINED HEREIN OR FOR DIRECT, INDIRECT, INCIDENTAL, SPECIAL, CONSEQUENTIAL, RELIANCE OR COVER DAMAGES, INCLUDING LOSS OF PROFITS, REVENUE, DATA OR USE, INCURRED BY ANY USER OR ANY THIRD PARTY IN CONNECTION WITH THE FURNISHING, PERFORMANCE, OR USE OF THIS MATERIAL, EVEN IF ADVISED OF THE POSSIBILITY OF SUCH DAMAGES.

The entire risk as to the quality and performance of software developed using this specification is borne by you. This disclaimer of warranty constitutes an essential part of the license granted to you to use this specification.

#### RESTRICTED RIGHTS LEGEND

Use, duplication or disclosure by the U.S. Government is subject to the restrictions set forth in subparagraph (c) (1) (ii) of The Rights in Technical Data and Computer Software Clause at DFARS 252.227-7013 or in subparagraph (c)(1) and (2) of the Commercial Computer Software - Restricted Rights clauses at 48 C.F.R. 52.227-19 or as specified in 48 C.F.R. 227-7202-2 of the DoD F.A.R. Supplement and its successors, or as specified in 48 C.F.R. 12.212 of the Federal Acquisition Regulations and its successors, as applicable. The specification copyright owners are as indicated above and may be contacted through the Object Management Group, 250 First Avenue, Needham, MA 02494, U.S.A.

#### TRADEMARKS

The OMG Object Management Group Logo®, CORBA®, CORBA Academy®, The Information Brokerage®, XMI® and IOP® are registered trademarks of the Object Management Group. OMG™, Object Management Group™, CORBA logos™, OMG Interface Definition Language (IDL)™, The Architecture of Choice for a Changing World™, CORBA services™, CORBA facilities™, CORBA med™, CORBA net™, Integrate 2002™, Middleware That's Everywhere™, UML™, Unified Modeling Language™, The UML Cube logo™, MOF™, CWM™, The CWM Logo™, Model Driven Architecture™, Model Driven Architecture Logos™, MDA™, OMG Model Driven Architecture™, OMG MDA™ and the XMI Logo™ are trademarks of the Object Management Group. All other products or company names mentioned are used for identification purposes only, and may be trademarks of their respective owners.

#### COMPLIANCE

The copyright holders listed above acknowledge that the Object Management Group (acting itself or through its designees) is and shall at all times be the sole entity that may authorize developers, suppliers and sellers of computer software to use certification marks, trademarks or other special designations to indicate compliance with these materials.

Software developed under the terms of this license may claim compliance or conformance with this specification if and only if the software compliance is of a nature fully matching the applicable compliance points as stated in the specification. Software developed only partially matching the applicable compliance points may claim only that the software was based on this specification, but may not claim compliance or conformance with this specification. In the event that testing suites are implemented or approved by Object Management Group, Inc., software developed using this specification may claim compliance or conformance with the specification only if the software satisfactorily completes the testing suites.

#### ISSUE REPORTING

All OMG specifications are subject to continuous review and improvement. As part of this process we encourage readers to report any ambiguities, inconsistencies, or inaccuracies they may find by completing the Issue Reporting Form listed on

---

the main web page <http://www.omg.org>, under Documents & Specifications, Report a Bug/Issue.

# Contents

---

<b>1.</b>	<b>Overview</b> .....	<b>1-1</b>
1.1	Introduction .....	1-1
<b>2.</b>	<b>Architectural Features</b> .....	<b>2-1</b>
2.1	Bridge Architecture Overview .....	2-1
2.2	Bridge Factory .....	2-3
2.3	Bridge Instance .....	2-4
2.4	Message Mapping .....	2-7
2.4.1	JMS Message to Event .....	2-7
2.4.2	Event to JMS Message .....	2-11
2.5	QoS Properties Mapping .....	2-14
2.5.1	Event Reliability .....	2-14
2.5.2	Connection Reliability .....	2-15
2.5.3	Delivery Reliability .....	2-15
2.5.4	Priority .....	2-15
2.5.5	Expiry times .....	2-16
2.5.6	Order Policy .....	2-17
2.6	Acknowledgment Mapping .....	2-18
2.6.1	Overview of Reliable Event Delivery with Event Acknowledgment .....	2-19
2.6.2	Mapping between Event Acknowledgment and JMS Message Acknowledgment .....	2-20
2.7	Transactional Support .....	2-22
2.7.1	Asynchronous Transactional Model .....	2-22
2.7.2	Supported configurations .....	2-24
2.7.3	Notification Service Transactional Role .....	2-25

---

2.7.4	Bridge Transactional Roles .....	2-26
2.7.5	JMS service provider Transactional Role .....	2-26
2.7.6	Bridge Transactional Monitoring .....	2-27
2.8	Conformance .....	2-30
<b>3.</b>	<b>Bridge Interfaces .....</b>	<b>3-1</b>
3.1	CosBridgeAdmin Module .....	3-1
3.1.1	ExternalEndPoint .....	3-4
3.1.2	EndPointSender interface .....	3-5
3.1.3	EndpointReceiver interface .....	3-6
3.1.4	Bridge Interface .....	3-6
3.1.5	Bridge Factory Interface .....	3-8
3.2	BridgeTransactionMgmt module .....	3-8
3.2.1	TransactionManagement interface .....	3-8
<b>4.</b>	<b>Extension to Existing OMG Specifications .....</b>	<b>4-1</b>
4.1	Editing Instructions for Extended Notification Service .....	4-1
4.2	IDL Modules .....	4-2
4.2.1	The CosNotifyCommAck Module .....	4-2
4.2.2	The CosNotifyChannelAdminAck Module .....	4-3
4.2.3	Overview of Event Acknowledgement .....	4-4
4.2.4	Scope of Event Acknowledgment .....	4-6
4.2.5	Sequence Number Header Field .....	4-7
4.2.6	Acknowledge operation behavior .....	4-10
4.2.7	Reliable Delivery Sequence .....	4-10
4.2.8	QoS Properties for Reliable Event Delivery .....	4-13
4.3	Notification Service QoS and Admin Property Extensions .....	4-14



## *Preface*

---

### *About This Document*

Under the terms of the collaboration between OMG and The Open Group, this document is a candidate for adoption by The Open Group, as an Open Group Technical Standard. The collaboration between OMG and The Open Group ensures joint review and cohesive support for emerging object-based specifications.

### *Object Management Group*

The Object Management Group, Inc. (OMG) is an international organization supported by over 600 members, including information system vendors, software developers and users. Founded in 1989, the OMG promotes the theory and practice of object-oriented technology in software development. The organization's charter includes the establishment of industry guidelines and object management specifications to provide a common framework for application development. Primary goals are the reusability, portability, and interoperability of object-based software in distributed, heterogeneous environments. Conformance to these specifications will make it possible to develop a heterogeneous applications environment across all major hardware platforms and operating systems.

OMG's objectives are to foster the growth of object technology and influence its direction by establishing the Object Management Architecture (OMA). The OMA provides the conceptual infrastructure upon which all OMG specifications are based. More information is available at <http://www.omg.org/>.

### *The Open Group*

The Open Group, a vendor and technology-neutral consortium, is committed to delivering greater business efficiency by bringing together buyers and suppliers of information technology to lower the time, cost, and risks associated with integrating new technology across the enterprise.

---

The mission of The Open Group is to drive the creation of boundaryless information flow achieved by:

- Working with customers to capture, understand and address current and emerging requirements, establish policies, and share best practices;
- Working with suppliers, consortia and standards bodies to develop consensus and facilitate interoperability, to evolve and integrate specifications and open source technologies;
- Offering a comprehensive set of services to enhance the operational efficiency of consortia; and
- Developing and operating the industry's premier certification service and encouraging procurement of certified products.

The Open Group has over 15 years experience in developing and operating certification programs and has extensive experience developing and facilitating industry adoption of test suites used to validate conformance to an open standard or specification. The Open Group portfolio of test suites includes tests for CORBA, the Single UNIX Specification, CDE, Motif, Linux, LDAP, POSIX.1, POSIX.2, POSIX Realtime, Sockets, UNIX, XPG4, XNFS, XTI, and X11. The Open Group test tools are essential for proper development and maintenance of standards-based products, ensuring conformance of products to industry-standard APIs, applications portability, and interoperability. In-depth testing identifies defects at the earliest possible point in the development cycle, saving costs in development and quality assurance.

More information is available at <http://www.opengroup.org/> .

## *OMG Documents*

The OMG Specifications Catalog is available from the OMG website at:

[http://www.omg.org/technology/documents/spec\\_catalog.htm](http://www.omg.org/technology/documents/spec_catalog.htm)

The OMG documentation is organized as follows:

### ***OMG Modeling Specifications***

Includes the UML, MOF, XMI, and CWM specifications.

### ***OMG Middleware Specifications***

Includes CORBA/IIOP, IDL/Language Mappings, Specialized CORBA specifications, and CORBA Component Model (CCM).

### ***Platform Specific Model and Interface Specifications***

Includes CORBA services, CORBA facilities, OMG Domain specifications, OMG Embedded Intelligence specifications, and OMG Security specifications.

---

## *Obtaining OMG Documents*

The OMG collects information for each book in the documentation set by issuing Requests for Information, Requests for Proposals, and Requests for Comment and, with its membership, evaluating the responses. Specifications are adopted as standards only when representatives of the OMG membership accept them as such by vote. (The policies and procedures of the OMG are described in detail in the *Object Management Architecture Guide*.) OMG formal documents are available from our web site in PostScript and PDF format. Contact the Object Management Group, Inc. at:

OMG Headquarters  
250 First Avenue  
Needham, MA 02494  
USA  
Tel: +1-781-444-0404  
Fax: +1-781-444-0320  
pubs@omg.org  
<http://www.omg.org>

## *Typographical Conventions*

The type styles shown below are used in this document to distinguish programming statements from ordinary English. However, these conventions are not used in tables or section headings where no distinction is necessary.

**Helvetica bold** - OMG Interface Definition Language (OMG IDL) and syntax elements.

**Courier bold** - Programming language elements.

Helvetica - Exceptions

Terms that appear in italics are defined in the glossary. Italic text also represents the name of a document, specification, or other publication.

## *Acknowledgments*

The following companies submitted and/or supported parts of this specification:

- Alcatel
- Fujitsu Limited
- IONA
- Prismtech



## 1.1 Introduction

Asynchronous messaging is a proven communication model for developing large-scale, distributed enterprise applications. In order to support flexible and end-to-end business integration, it is becoming necessary to provide messaging interworking between CORBA applications and Java / EJB.

The CORBA Notification Service is the OMG mature standard that allows Corba objects, named suppliers, to send event asynchronously to other Corba object named consumers. Suppliers are de-coupled from consumers by means of event channel concept, which takes care of dissemination of events to them.

The Java Message Service (JMS) defines a standard API that provides a simplified and common way for Java clients to access message oriented middleware. More importantly, JMS is tightly integrated into J2EE and is the messaging standard for Enterprise Java Beans (EJB). Applications publishing a message are de-coupled from applications receiving them by the means of a Queue or topic concept.

The Notification Service differs from JMS in that its specification covers both the client interfaces and the messaging engine whereas JMS was designed as an abstraction over existing and new messaging products. The JMS messaging engine implementation may differ from one vendor to another.

This document specifies architecture and interfaces for managing Notification Service interworking with Java Message Service. The interworking involves several aspects such as:

- Event -Message mapping,
- QoS mapping,

- Event and Message Filtering,
- Automatic federation between Notification Service channel concept and topic/queue concepts
- Transaction support.

### *2.1 Bridge Architecture Overview*

The bridge defined by this specification is designed to manage and interconnect an event channel with a JMS destination. A clear goal of this specification is to define the capability to manage an inter-related channel and JMS destination that can be created via existing implementations of those services. The guiding principles which drove the definition of the Bridge IDL interfaces were to preserve backward compatibility with both JMS and Notification Service programming models. This specification is JMS 1.1 compliant. Extensions to current Notification Service can be required only in advanced use cases where acknowledgment data delivery QoS is required.

Figure 2-1 depicts the general architecture for the bridge. The IDL module names of the interfaces defined by the Notification Service and the Bridge are abbreviated in the diagram. NCA stands for CosNotifyChannelAdmin, while NC stands for CosNotifyComm, finally BA stands for CosBridgeAdmin.

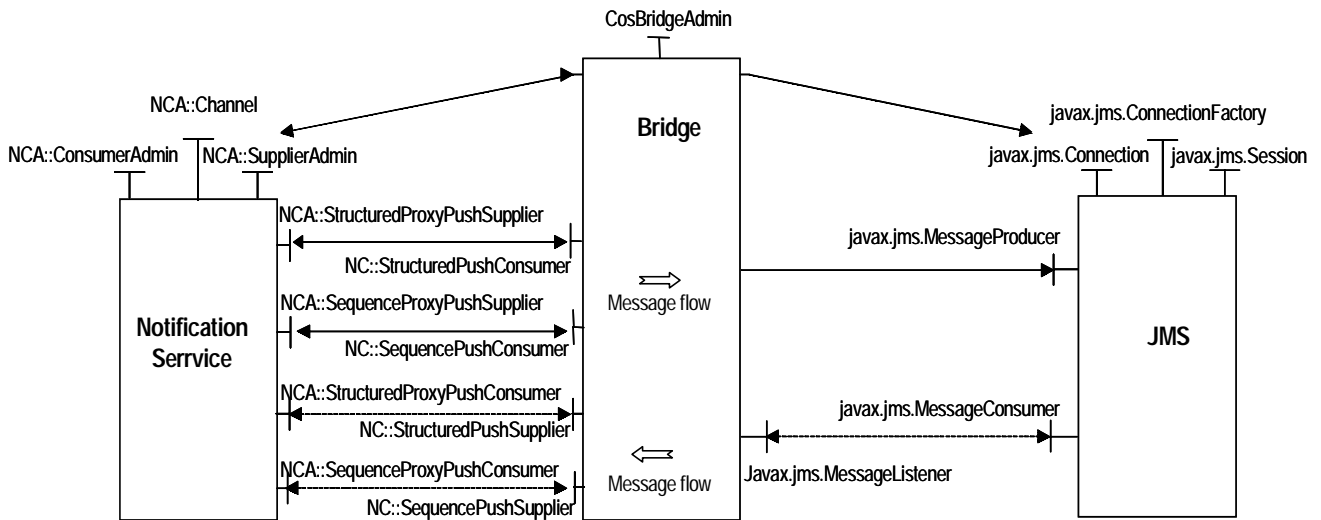

Figure 2-1 General Architecture of the Bridge

The Bridge is used to create and manage bridges instances that perform automatic mapping and forwarding of messages and events. Figure 2-1 shows the different relationships between the bridge, the notification service, and the JMS. For the sake of clarity only the push communication style is considered in Figure 2-1.

To preserve the Notification service and JMS interfaces, the Bridge behaves as an event Consumer and as a JMS sender when forwarding an event from the event channel to the JMS destination. In addition, it behaves as a JMS receiver and an event Producer when forwarding a message in the other direction.

Event-grouping is crucial to improve interworking performance. This makes structured events centric in the JMS-NS message mapping, consequently, when the push communication style is selected the Bridge supports the standard StructuredPushConsumer, SequencePushConsumer and StructuredPushSupplier and SequencePushSupplier interfaces. It supports also the StructuredPullConsumer, SequencePullConsumer and StructuredPullSupplier and SequencePullSupplier interfaces.

This interworking specification also uses interfaces from the **CosNotifyCommAck** module and the **CosNotifyChannelAdminAck** module.

To receive messages from JMS, the bridge offers the standard JMS `javax.jms.MessageListener` interface and makes use of JMS `javax.jms.MessageProducer` and `javax.jms.MessageConsumer` interfaces.

The bridge is also used to automate the connection setups between channel and JMS destination. It performs on behalf of JMS the necessary steps to create and configure entry points in the event channel. These steps involve StructuredProxyPush creation and default QoS setting. Similarly, it performs on behalf of the notification service steps needed to create and configure connection and session with JMS provider.



---

**Note** – Issues related to detection of event or message duplication in complex topologies is out of the scope of this specification and are not taken into account. Alternatively, techniques such as those used in Event Domain Management can be used.

---

## 2.2 *Bridge Factory*

A BridgeFactory is responsible for the creation of Bridge objects based on initial parameters. In order to create a bridge, it is necessary to have provide information on an existing Notification Service event channel and JMS destination. Channel and JMS destination information are abstracted using external end point connector concept.

An external end point connector may provide or consume data flow. It can be either a source or sink of data. When an external end point connector describes a JMS destination it should indicate the type and the name of the destination, given it be a topic or queue. When it describes channel information it should indicate whether data will be sent using sequence or single structured events. Finally, the BridgeFactory user should indicate the communication style it wishes to use. The communication style can be either Push or Pull.

Since the JMS specification supports Pull communication style on the application receiver side only, the BridgeFactory should check the consistency of the end-to-end <sup>1</sup> communication model in use before creating a bridge. For example, when forwarding data from event channel to JMS destination, the Pull communication style can't be set at the sink external endpoint. This scenario is summarized in Table 2-1.

Some other consistency checking of the end-to-end communication model is implementation dependent. For example, bridge implementation with storage capabilities may support PUSH communication style at JMS side acting as a source and PULL communication style at event channel side acting as a sink only and only if the bridge uses buffer that de-synchronize data transmission from its reception by event channel.

Controls performed by Bridgefactory are summarized in Table 2-1.

---

1.End-to-end portion concerns the source to sink endpoints.

Table 2-1 Communication Consistency Checking

Source: Channel		Sink: JMS	
		PUSH	PULL
	PUSH	yes	Not Allowed by JMS specification
	PULL	yes	Not Allowed by JMS specification
	PULL	yes	Not Allowed by JMS specification

Source: JMS		Sink:: Channel	
		PUSH	PULL
	PUSH	Yes	Implementation dependent
	PULL	Yes <sup>1</sup>	yes
	PULL	Yes <sup>2</sup>	Yes

1. To be able to pull the JMS and to push toward event channel, a kind of scheduling can be passed to the bridge using the `CosNotification::PacingInterval` QoS defined at each external endpoint side.
2. To be able to pull the JMS and to push toward event channel, a kind of scheduling can be passed to the bridge using the `CosNotification::PacingInterval` QoS defined at each external endpoint side.

A compliant bridge implementation is not required to support all communication models described in Table 2-1. However, vendors are encouraged to provide several communication styles to increase bridge flexibility.

## 2.3 Bridge Instance

To propagate unidirectional data flow a bridge instance connects a single source endpoint to a single sink endpoint. This object offers two interfaces that fit the source and sink nature and requirements. A source is connected to the bridge instance through the Endpoint receiver and the sink is connected through the Endpoint sender. When bi-directional interworking between the Notification Service and JMS is required two bridge instances can be created separately. Figure e2-2 summaries the bridge architecture abstract view.

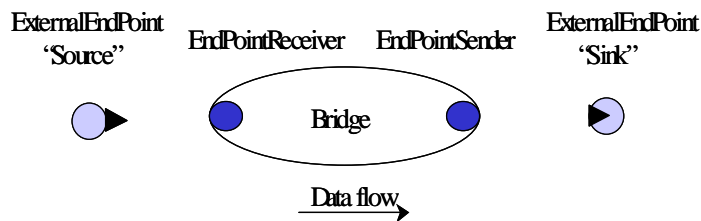

Figure 2-2 Bridge abstract Architecture

Depending on the source endpoint nature it is connected to, the endpoint receiver can be a:

- JMS Message Listener, if it receives messages from a JMS destination. At the abstract level, the JMS Message Listener behaves as an event Push Consumer, in that it offers the onMessage operation which, from the functional viewpoint, can be compared to the push operation defined in Notification Service.
- JMS Message Consumer, when it retrieves messages from a JMS destination. It can be compared to an event pull consumer.
- Structured push consumer, if it connects an event channel pushing structured events.
- Sequence push consumer, if it connects an event channel pushing sequence of structured events.
- Structured pull consumer, if it connects an event channel offering pull structured event operations.
- Structured pull consumer, if it connects an event channel offering pull structured event operations.

The endpoint sender can behave as a:

- JMS Message producer, when sending events to a JMS destination.
- Structured push supplier, when sending events to an event channel.
- Sequence push supplier, when sending events to an event channel.
- Structured pull supplier, when pulling events from an event channel.
- Sequence pull supplier, when pulling events from an event channel.

When creating a bridge, regular steps to connect the event channel and the JMS destination are performed. They consist of:

1. Obtaining administration object references from event channel and JMS. On event channel side, those object references are SupplierAdmin or ConsumerAdmin and on the JMS side those objects references correspond to Connection and Session.
2. Creating on event channel side proxySupplier or proxyConsumer objects and creating on JMS side MessageProducer or MessageConsumer objects that fit communication style and data grouping policy selected by user.

A bridge is a stateful object that reflects the connection states with both proxy and JMS destination entry. Consequently, the bridge state is an aggregation of Proxy states and the JMS destination entry state it is connected to. The AND logical operator semantic should be applied to obtain the bridge state.

When it is created the bridge status should be set to Inactive. When starting the bridge, the endpoint receiver and sender should activate simultaneously the connections with the proxy and JMS destination entry. If these two steps are successfully achieved the bridge state become Active.

The bridge evolve to Inactive state when at least one connection with the proxy or JMS destination is lost or suspended.

The bridge interface offers the following operations: start, stop, get\_status, and destroy.

The start operation activates the two connections with the proxy and JMS destination entry. connect\_XXX operations class provided in **CosNotifyChannelAdmin** module are used to establish connection with event channel proxy object. The JMS `javax.jms.Connection.start` operation can be used to activate connexion with JMS provider. The invocation of the start operation on bridge inactivated by the use of stop operation resumes the connexions with the proxy and JMS destination entry. The resume\_connection operations provided in the **CosNotifyChannelAdmin** module and the `javax.jms.Connection.start` operation can be respectively used. When the bridge successfully invokes connect\_XXX or resume\_connection and `javax.jms.Connection.start`, its state become Active.

Exception behavior of the Bridge Interface operations is described in Chapter 3.

The stop operation stops the connections with the proxy and JMS destination entry. The suspend\_connection operations class provided in **CosNotifyChannelAdmin** module and the JMS `javax.jms.Connection.stop` operation can be respectively used to suspend the connection with event channel proxy object and the connexion with JMS provider. When the connections with the proxy and JMS destination entry are successfully suspended the bridge state becomes Inactive.

The get\_status operation is intended to describe the status of end-to-end connection stating from source to sink endpoints. To return up-to-date status, the bridge can use the JMS `exceptionListener` interface to detect Connexion problems with JMS provider. Since Notification Service does not provide tools to get the connection status of proxy, the bridge implementation may use connect\_structured\_XXX operations to deduce the connection status. The use of this operations class is idempotent. When receiving **AlreadyConnected** exception, the connection status is active. Otherwise, the status is considered inactive.

The destroy operation destroys the bridge object, invalidating its object reference. To liberate resources on the event channel and JMS sides the disconnect\_XXX class provided in **CosNotifyChannelAdmin** module and the `javax.jms.Connection.close` operations should be respectively invoked before destroying the bridge object.

---

**Note** – A Table summarizing the mapping can be added if necessary

---

Beside the configuration steps described above, the bridge perform data mapping from structured event format to JMS message formats and vice versa. The bi-directional mapping is described in Section 2.4, “Message Mapping,” on page 2-7.

---

**Note** – The `CosNotification::AdminPropertiesAdmin` and `interface QoS` interface and values related to queue management & data delivery can extend the Bridge interface for implementation that support asynchronous delivery case.

---

---

**Note** – Filtering support will be discussed in future versions in Section 2.7, “Transactional Support,” on page 2-22.

---

## 2.4 Message Mapping

The JMS specification defines five different messages that all derive common functionality from the base Message interface. The Notification Service specification defines three event types and associates them well defined translation rules making the consumption of events produced in different formats possible.

The Notification Service specification made event grouping possible through structured event sequences only. Event-grouping is crucial to improve interworking performance. This makes structured events centric in the JMS -NS message mapping. This section describes the mapping between structured events and the different JMS message types, namely:

- TextMessage
- StreamMessage
- BytesMessage
- MapMessage\*
- ObjectMessage\*



Figure 2-3 Structured event role in data mapping

A JMS message consists of a header, a set of properties and a body. The header and properties are the same for all message types. The body part is different for each of the five different JMS message types.

Structured Events provide a well-defined data structure which is comprised of two main components: a header and a body. The header can be further decomposed into a fixed portion and a variable portion.

The current version of the specification addresses bidirectional mapping without information loss. Future version may be enhanced by customizable mapping interfaces that discard irrelevant data for the application receiver and event consumer.

### 2.4.1 JMS Message to Event

This section describes the mapping of message sent by JMS client toward Notification Service Consumer. The mapping of the JMS Message header and properties part is independent from the message type. The body mapping depends on the message types enumerated above.

### *JMS Header and properties mapping*

When possible, the mapping from JMS to structured event should follow the general naming conventions adopted by the Notification Service specification when translating generic event (Any) or typed event types to structured event. Structured event fields such as **domain\_name**, **type\_name**, and **event\_name** should be compliant with the notation adopted in section 2.1.4 of the Notification Service specification.

- The **domain\_name** data member should be set to empty string.
- The **type\_name** data member should start with the “%” character and indicate the JMS message source type, namely, the **TextMessage**, **MapMessage**, **StreamMessage**, **BytesMessage**, or **ObjectMessage**. For example, the **type\_name** data member would be set to the value “%TextMessage” if the JMS source message type is **textMessage**.
- The semantics associated with **event\_name** data member is used by end-users only, it is not interpreted by any component Notification Service. This field can be optionally set to the **Topic** or the queue name through which JMS message was published or sent. The extra-information delivered within **event\_name** field may be used by a JMS-aware event consumer.

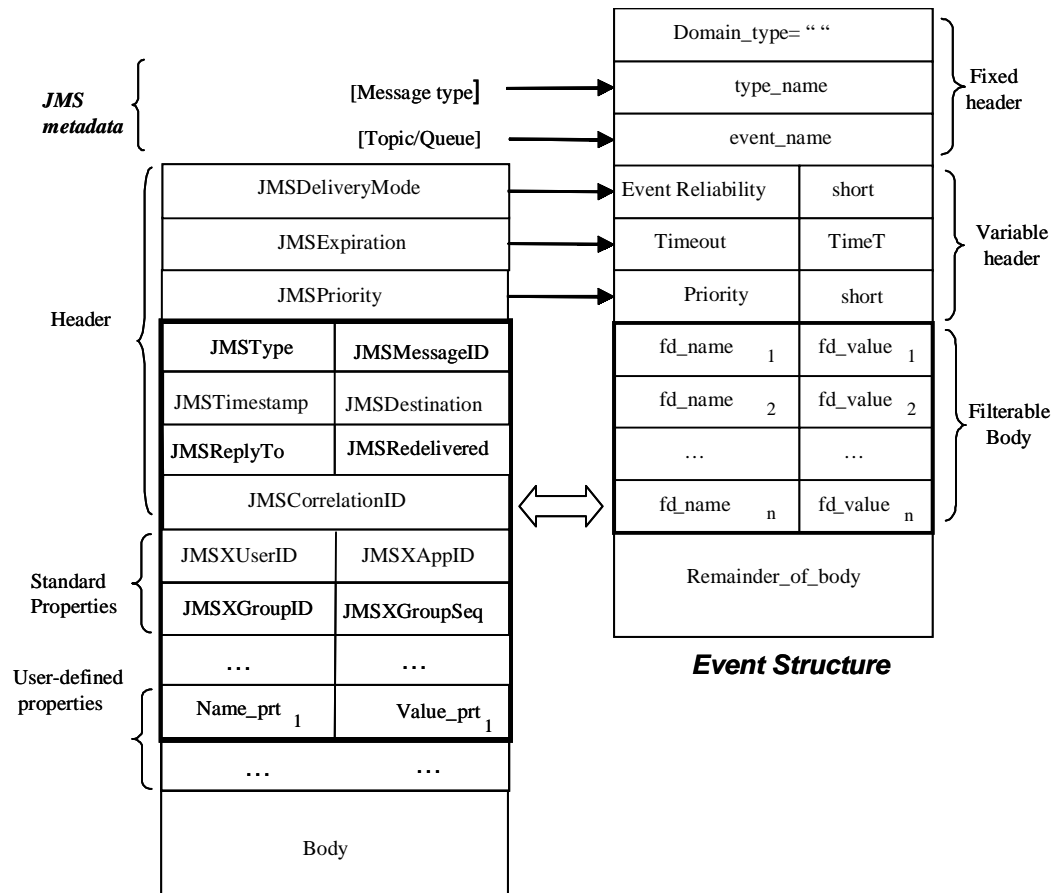

Figure 2-4 JMS message to Structured Event mapping

The JMS Message header is made up by several fields for setting various Quality of Service (QoS) such as JMSDeliveryMode, JMSExpiration, and JMSPriority. Those fields have well-defined meanings in the structured event and they must be mapped as follow:

- JMSDeliveryMode maps to The EventReliability QoS in the variable header of a structured event. It is set to Persistent when the delivery mode is PERSISTENT. Otherwise, the EventReliability QoS is set to BestEffort.
- JMSExpiration maps to the Timeout in the variable header of a structured event. JMS expiration time value is expressed in milliseconds. This value is converted to units of 100 nanoseconds as this is the base unit of time in CORBA. Expired messages are not visible to clients.
- JMSPriority maps to the JMS message priority. It is mapped to the Priority QoS in the variable header of structured events. Priority delivery mode is used to ensure that messages with higher priority are delivered before messages with lower priority values.

The rest of the JMS header fields can't be mapped directly to standard structured event fields of the variable header portion; however those fields can be viewed as optional information that may be useful for JMS-aware event consumer. For example, a `JMSReplyTo` field with a valid value can be used by event consumer that would like to react, after receiving the JMS message converted into a structured event, by producing a new event which can be seen as reply message. The reply message will be sent through channel linked up with the destination specified into the `JMSReplyTo` field. In this case the `JMSCorrelationID` may also be reused by event consumer in the reply message to allow the JMS sender to tie up with the initial message it sent.

To increase filtering capability on the event channel side, the `JMSType`, `JMSMessageID`, `JMSTimestamp`, `JMSReplyTo`, `JMSCorrelationID`, `JMSDestination`, `JMSRedelivered` fields are mapped, by default, to the filterable data member of the structured event. Each of them is inserted using the name-value pair, i.e using the `PropertySeq` data type defined in the `CosNotification` module.

To decrease the structured event length and increase performance, JMS header fields with nil values can be omitted during the mapping process.

The JMS property fields, prefixed by `JMSX`, are optional part of the JMS message structure. Some of them are standard and well defined by JMS specification, as those enumerated in the Figure 2-4, others are defined by JMS end-user. In the current version of the specification, the default behavior is to map all `JMSX` fields. Future version may restrict the mapping to `JMSX` fields that are relevant to the event consumer. This will improve performance and mapping pertinence.

All `JMSX` Property values are java primitives data type, they can be boolean, byte, short, int, long, float, double, and String. They are all entered into the filterable body of the structured event using the name-value pair, i.e using the `PropertySeq` data type defined in the **CosNotification** module and they are mapped using the standard Java to IDL mapping.

The order of JMS properties is not defined in JMS. The Notification-JMS specification doesn't mandate any particular order when implementing the mapping.

### *2.4.1.1 JMS message body mapping*

It is expected that the text, map, and stream messages will be the three specific message types intensively used in an environment that consists of both JMS and non-JMS clients.

#### *2.4.1.1.1 Text Message*

A `TextMessage` provides a body, which is a Java String. The body is inserted into a `remainder_of_body` of the structured event by simply inserting the string into the `Any`.

#### *2.4.1.1.2 Stream Message*

A `StreamMessage` provides a body which contains a stream of Java primitive values. The values on the stream stack are written onto the `remainder_of_body` of the structured event using the `AnySeq` data type. The elements in this sequence are mapped using the standard Java to IDL mapping.



#### **2.4.1.1.3 Map Message**

A MapMessage provides a body of name-value pairs where names are Strings, and values are Java primitives. The body can be inserted in the remainder\_of\_body field, of a structured event using the PropertySeq data type.

#### **2.4.1.1.4 Bytes Message**

A bytes message supports a body with un-interpreted data. The message supports the methods of the DataInputStream and DataOutputStream interfaces from the Java I/O package. As the body is an array of bytes it is written to the remainder of the body field of a structured event using an IDL octet sequence. The OctetSeq data type is defined in the notification service IDL extension module.

#### **2.4.1.1.5 Object Message**

An object message provides a body that can contain any Java object that supports the Serializable interface. This type of message is serialized onto a byte sequence and written onto the any in the remainder of the body using the same OctetSeq data type described above. On the receiver side the byte sequence is converted to an object input stream where the object is read from.

### **2.4.2 Event to JMS Message**

When a message is sent from a Notification Service event channel to JMS destination, the construction of the JMS message is performed as follows:

1. When defined, the standard optional part of the event variable header is mapped to corresponding fields in JMS header. If the event supplier does not define those fields, then JMS header fields are populated using the default values specified in the JMS specification.
2. The data in the event fixed header, the rest of the optional header fields as well as the event filterable body are placed in the JMS properties fields. They will be seen by the JMS receiver application as user-defined fields.
3. Meta data created by JMS-NS bridge is used to define complete JMS missing fields such as JMSTDestination or JMSMessageID.
4. The remainder\_of\_body section is mapped to the JMS message body depending on the complexity of the data format wrapped in the Any.

#### **Structured Event Header and filterable body mapping**

When defined in structured event, the EventReliability, Timeout, or Priority fields are respectively mapped to JMSDelivery, JMSpriority, and JMSTimetolive. If EventReliability is not defined JMSDelivery is set to PERSISTENT. If the Timeout is not defined JMSTimetolive to Unlimited. If the Priority is not defined the JMSpriority is set to 4.

The User-defined property fields are pair of name-value. The structured event fixed header fields are mapped to the JMS message User-defined property fields as follows:

- **domain\_type**: A new property name labeled \$domain\_type is created. It must obey the rules for a message selector identifier<sup>1</sup> specified in Section 3.8.1.1 of JMS specification. The content of the domain\_type field in the event is converted to java String.
- **type\_name**: A new property name labeled \$type\_name is created. It must obey the rules for a message selector identifier specified in Section 3.8.1.1 of JMS specification. The content of the type\_name field in the event is converted to java String.
- **event\_name**: A new property name labeled \$event\_name is created. It must obey the rules for a message selector identifier specified in Section 3.8.1.1 of JMS specification. The content of the event\_name field in the event is converted to java String.

Inputs of JMSMessageID, JMSTimestamp, JMSDestination, and JMSType fields are fulfilled by JMS-NS bridge.

- JMSMessageID is a String value which should be a unique key, prefixed by 'ID'. The exact scope of uniqueness is provider defined.
- JMSTimestamp field contains the time a message was handed off to JMS to be sent. It is in the format of a normal Java millis time value.
- JMSDestination contains the topic or the Queue name to which the message is being sent.
- JMSType is a String value that should be set to 'Structured Event'.

Complete specification those header fields are defined in the JMS specification.

---

1. An identifier is an unlimited-length character sequence that must begin with a Java identifier start character; all following characters must be Java identifier part characters. An identifier start character is any character for which the method `Character.isJavaIdentifierStart` returns true. This includes '\_' and '\$'.

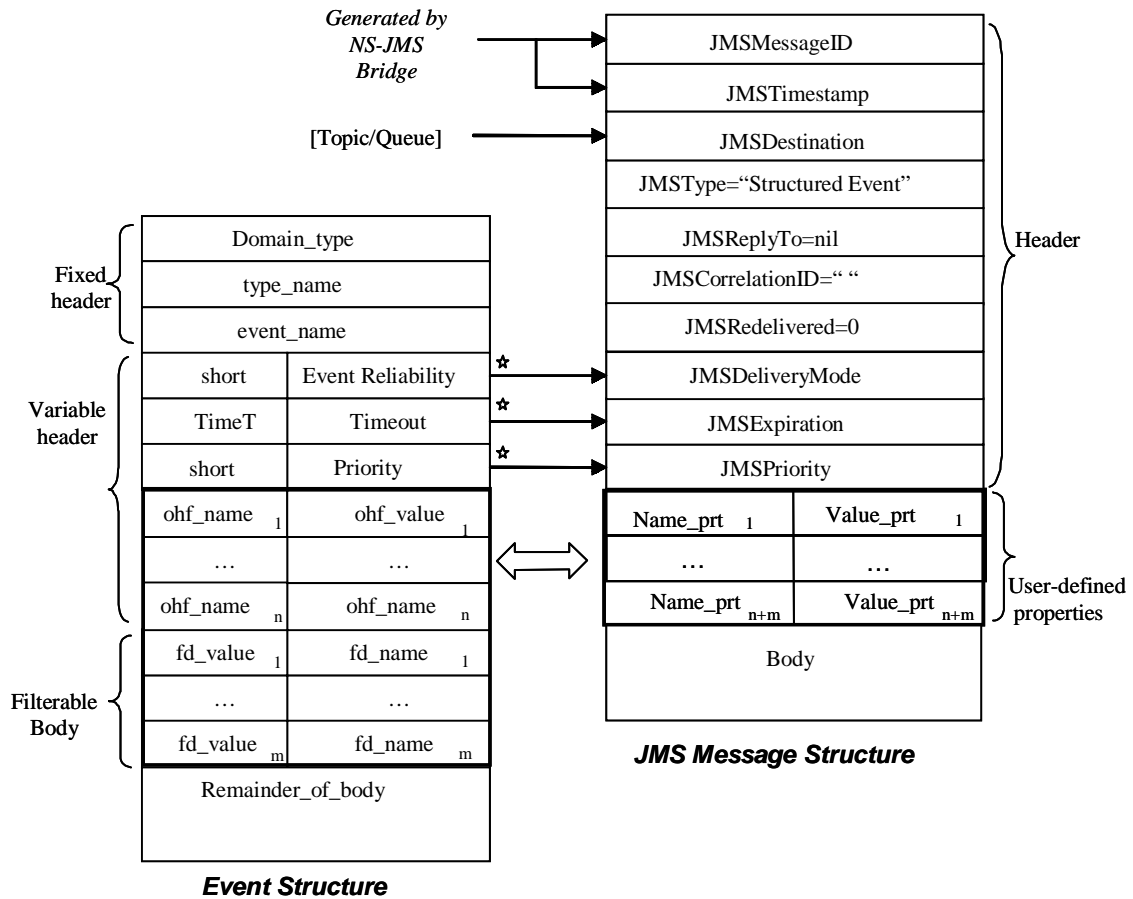

Figure 2-5 Structured Event to JMS message mapping

For each optional header (ohf\_\*) or filterable data (fd\_\*) field a new property name labeled \$ohf\_\* or \$fd\_\* is created. It must obey the rules for a message selector identifier specified in Section 3.8.1.1 of JMS specification. The content of the ohf\_\* or fd\_\* field is converted to java data type primitives.

If the optional header or filterable data field has the struct IDL type then multiple JMS properties are created, one for each primitive element of the complex type. The structure is linearized as follow:

- The new \$ohf\_\* or \$fd\_\* field name is concatenated with the structure and the member of the structure names. The structure member operator '.' is used to delimitate each name. This process is repeated if the structure contains nested data structures as elements, along with primitive elements. In turn, each Struct is expanded if and only if all of its non-nested elements are primitive types.
- The content of the linearized field is converted to java data type primitives.

For example if the structured event contains the pair <name/value>= <Fd\_name1, CORBA::Any A>, and the A value wraps the structure named Alarm { string Al\_name; int Severity }, then this field will be transformed into two JMS user defined properties (fields) : <\$Fd\_name1.Al\_name, string> and <\$Fd\_name1.Severity, integer>.

If the optional header or filterable data field has other complex data types, it is mapped to bytes stream, the JMS client that would receive a bytes stream have to use the appropriate CORBA Helper classes to unmarshal the user data.

### ***Structured Event Remainder of body mapping***

The mapping of structured event body to given JMS message type body depends on the complexity of the data wrapped into remainder\_of\_body field.

When remainder\_of\_body typed Any involves:

- IDL basic type elements, each element maps to a java primitive type using standard IDL to java mapping. The set of elements obtained are entered in JMS StreamMessage body.
- String type element only, it maps to java string type and is placed in JMS message body.
- Sequence of Properties (PropertySeq), it maps to a body of name-value where names are strings and values are java primitives.
- Octet Sequence or other type such as user constructed types, it maps to a body of BytesMessage. To reconstruct the IDL type, the JMS client that would receive a BytesMessage have to use the appropriate CORBA Helper class.

## ***2.5 QoS Properties Mapping***

The Notification Service and the JMS have each specific QoS properties. In the Notification Service, QoS properties are specified in the header of Structured Events, Proxy, Admin and Channel object. In the JMS, QoS Properties are specified in the header of JMS messages and some objects in JMS Provider. This section describes the bi-directional mapping of QoS properties between the Notification Service and the JMS.

### ***2.5.1 Event Reliability***

The Notification Service's QoS property EventReliability is mapped to JMS QoS property JMSDeliveryMode. Each value of the properties are mapped as follows:

Table 2-2 Event Reliability

<b>EventReliability</b>	<b>JMSDeliveryMode</b>
BestEffort	NON_PERSISTENT
Persistent	PERSISTENT

## 2.5.2 Connection Reliability

The Notification Service's QoS property ConnectionReliability is mapped to QueueReceiver object in the JMS Point-to-Point model or TopicSubscriber object in the JMS Publish/Subscribe model. Each value of the property is mapped as follows:

Table 2-3 Connection Reliability Mapping

ConnectionReliability	JMS Point-to-Point model	JMS Publish/Subscribe model
BestEffort	[no supported]	TopicSubscriber
Persistent	QueueReceiver	Durable TopicSubscriber

The JMS Publish/Subscribe model has both durable and not durable subscriber objects. Each subscriber is mapped to the corresponding value of ConnectionReliability. The JMS Point-to-point model has only the durable receiver object QueueReceiver. It is mapped to the Persistent value of ConnectionReliability. Since the JMS Point-to-point model does not have not durable subscriber objects, BestEffort of ConnectionReliability can't be used in interworking with JMS Point-to-Point model.

## 2.5.3 Delivery Reliability

The Notification Service's QoS property DeliveryReliability is an additional property of this specification (see Section 2.6.6, "QoS Properties for Reliable Event Delivery"). This QoS property is mapped to JMS reliable messaging functions. Each value of the property is mapped as follows:

Table 2-4 Delivery Reliability Mapping

DeliveryReliability	JMS reliable messaging functions
None	[no use of any reliable messaging functions]
Acknowledgment	Message Acknowledgment

## 2.5.4 Priority

The Notification Service's QoS property Priority is mapped to the JMS QoS property JMSPriority. The value of the Notification Service's Priority is represented by short integer, where -32,767 is the lowest priority and 32,767 the highest. The JMSPriority is represented by ten values, where 0 is the lowest priority and 9 the highest. Since the range of the value is very different between Notification Service and JMS, this specification defines following priority mapping as default mapping which must be supported. Other mappings may be supported in addition to the default mapping if necessary.

When the value of JMSPriority is converted to the value of Notification Service's Priority, same value on JMSPriority is used as the value of Notification Service's Priority as follows:

Table 2-5 Priority mapping from JMS to Notification

<b>JMSPriority</b>	<b>Priority</b>
0	0
1	1
2	2
3	3
4	4
5	5
6	6
7	7
8	8
9	9

When the value of Notification Service's Priority is converted to the value of JMSPriority, some values on Notification Service's Priority are integrated with value 0 or 9 on JMSPriority as follows:

Table 2-6 Priority mapping from Notification to JMS

<b>Priority</b>	<b>JMSPriority</b>
-32,767 ... 0	0
1	1
2	2
3	3
4	4
5	5
6	6
7	7
8	8
9 ... 32,767	9

### 2.5.5 Expiry times

The Notification Service's QoS property StopTime is mapped to the JMS QoS property Timeout.

## 2.5.6 Order Policy

The JMS's order policy requires to satisfy following two conditions:

1. Fifo ordering: Messages must be received in the order they were sent.
2. Priority ordering: However higher priority messages may jump lower priority messages.

The priority ordering, second condition above, is not mandatory. The JMS specification says:

JMS does not require that a provider strictly implement priority ordering of messages; however, it should do its best to deliver expedited messages ahead of normal messages. ("3.4.10 JMSPriority" in JMS 1.1).

Thus JMS's order policy can be mapped to one of two values in the Notification Service's QoS property OrderPolicy as follows:

Table 2-7 Priority Mapping

OrderPolicy	JMS's order policy
AnyOrder	[not supported]
FifoOrder	Supported
PriorityOrder	
DeadlineOrder	[not supported]

The selection of the mapping depends on Notification Service implementation. If an implementation of Notification Service's PriorityOrder value guarantees fifo ordering in same priority events, it is best that JMS's order policy is mapped to Notification Service's PriorityOrder value. In this case, both JMS's two ording conditions are satisfied.

However the Notification Service specification does not require to guarantee fifo ordering in same priority events on PriorityOrder value. If an implementation of PriorityOrder value does not support this function, JMS's order policy should be mapped to Notification Service's FifoOrder value. Because the fifo ordering is mandatory condition, but the priority ordering is not mandatory condition in JMS.

Even if well-defined translation is executed on event channel between some Structured Events on a logical connection and an event batch (sequence of Structured Event), event order must be preserved for all events in FifoOrder value or for same priority events in PriorityOrder value Figure 2-6 and Figure 2-7. The first event on the logical connection is translated from/to the top of the event batch, and the last event on the logical connection is translated from/to the bottom of the event batch.

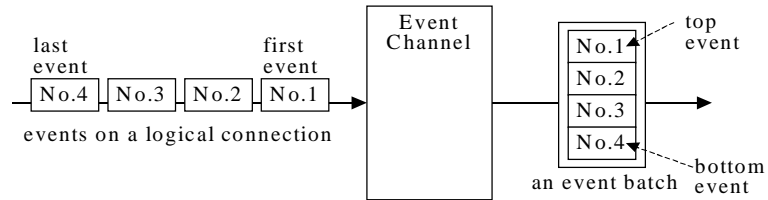

Figure 2-6 Preservation of event order in translation from Structured Events to event batch

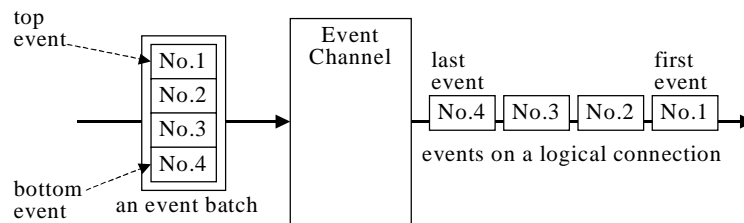

Figure 2-7 Preservation of event order in translation from event batch to Structured Events

## 2.6 Acknowledgment Mapping

The JMS QoS API has two kinds of function for reliable messaging on the JMS MessageConsumer side:

- one using transactions, and;
- the other using Message Acknowledgment.

The use of acknowledgments or transactions provide different forms of reliability. These two forms represent different use models: The use of acknowledgments provides a model where each message can be guaranteed to be delivered. If the message is not delivered, the message queue or topic can take steps to redeliver it. While this could be done within a transaction, the transactional model is fairly heavyweight for a single event, such as assuring the delivery of a single message. However, messages can also be part of a more complex set of actions, and in that context it makes a great deal of sense to include a message in a distributed transaction. For example, there may be a sequence of events where upon the receipt of a message, a database must be updated, and then a message sent to trigger some additional processing. The application designer might choose to bracket these actions within a transaction, so that if the message is not successfully delivered, all of the additional actions can be rolled back. If a message is part of a transaction, then the acknowledgment semantics are not used. The two models exist because there are a range of possible applications, not all of which would require transactions.



This section describes the mapping between the JMS Message Acknowledgment and the Notification Service.

### *2.6.1 Overview of Reliable Event Delivery with Event Acknowledgment*

According to the JMS specification, reliable messaging with JMS Message Acknowledgment shall satisfy the following conditions:

- No lost messages
- No duplicate delivery of messages
- Preserve message order

However the Notification Service lacks the required acknowledgment functions to satisfy the first and second conditions above. This specification adds the required acknowledgment functions, called Event Acknowledgment, to the Notification Service so that the JMS Message Acknowledgment can be mapped to the Notification Service.

To realize the Event Acknowledgment satisfying the conditions above, this specification defines DeliveryReliability QoS property, AckNotify interface, SequenceNumber header field and Reliable Delivery Sequence.

- DeliveryReliability QoS property specifies what reliable event delivery mechanism is used. When the value Acknowledgment is specified, the Event Acknowledgment is applied to event delivery.
- The extended Notification Service defines an acknowledge operation. It is included in a new set of interfaces, each of which extends one of the following interfaces: StructuredPushSupplier, StructuredPullSupplier, SequencePushSupplier, SequencePullSupplier, StructuredProxyPushSupplier, StructuredProxyPullSupplier, SequenceProxyPushSupplier, and SequenceProxyPullSupplier. These extended interfaces each add the acknowledge operation to the interface they derive from. Each of these interfaces, defined in the Extended Notification Service, each have the suffix "Ack" added the name of the interface they inherit from.
- SequenceNumber header field, as defined in the Extended Notification Service, indicates a serial number on each event. It is used to check duplication of same event and to prevent lost of event.
- Reliable Delivery Sequence, as defined in the Extended Notification Service, defines a sequence of reliable event delivery with the acknowledge operation and the SequenceNumber header field. The Reliable Delivery Sequence is applied to event delivery between supplier (or proxy supplier) and consumer (or proxy consumer) when the value of DeliveryReliability property is Acknowledgment.

## 2.6.2 Mapping between Event Acknowledgment and JMS Message Acknowledgment

The JMS Message Acknowledgment is mapped to the Notification Service's Event Acknowledgment. On one hand the JMS MessageConsumer has sending functions of acknowledgment, on the other hand the JMS MessageProducer does not have received functions of acknowledgment. Thus the acknowledgment functions between JMS and Notification Service is mapped on only consumer side Bridge.

The JMS MessageConsumer has two kinds of message delivery mode: asynchronous delivery with onMessage method and synchronous delivery with receive or receiveNoWait method. The asynchronous delivery is mapped to the Notification Service's push model as follows:

Table 2-8 Asynchronous delivery mapping

push model(XXXXXX: Structured or Sequence)	JMS asynchronous delivery
push operation in XXXXXPushConsumer interface	onMessage method without Message Acknowledgment
push operation in XXXXXPushConsumer interface and acknowledge operation in XXXXXProxyPushSupplier interface	onMessage method with DUPS_OK_ACKNOWLEDGE
	onMessage method with AUTO_ACKNOWLEDGE
push operation in StructuredPushConsumer interface and acknowledge operation in StructuredProxyPushSupplier interface	onMessage method and acknowledge method of CLIENT_ACKNOWLEDGE

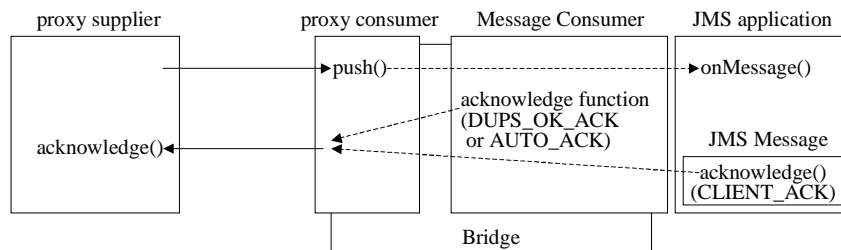

Figure 2-8 Asynchronous delivery mapping

The synchronous delivery is mapped to the Notification Service's pull model as follows:

Table 2-9 Synchronous Delivery Mapping

waiting policy	pull model(XXXXXX: Structured or Sequence)	JMS synchronous delivery
waiting for message	pull operation in XXXXXProxyPullSupplier interface	receive method without Message Acknowledgment
	pull and acknowledge operations in XXXXXProxyPullSupplier interface	receive method with DUPS_OK_ACKNOWLEDGE
		receive method with AUTO_ACKNOWLEDGE
	pull and acknowledge operations in StructuredProxyPullSupplier interface	receive method andacknowledge method of CLIENT_ACKNOWLEDGE
no waiting	try_pull operation in XXXXXProxyPullSupplier interface	receive NoWait method without Message Acknowledgment
	try_pull and acknowledge operations in XXXXXProxyPullSupplier interface	receive NoWait method with DUPS_OK_ACKNOWLEDGE
		receive NoWait method with AUTO_ACKNOWLEDGE
	try_pull and acknowledge operations in StructuredProxyPullSupplier interface	receiveNoWait method and acknowledge method of CLIENT_ACKNOWLEDGE

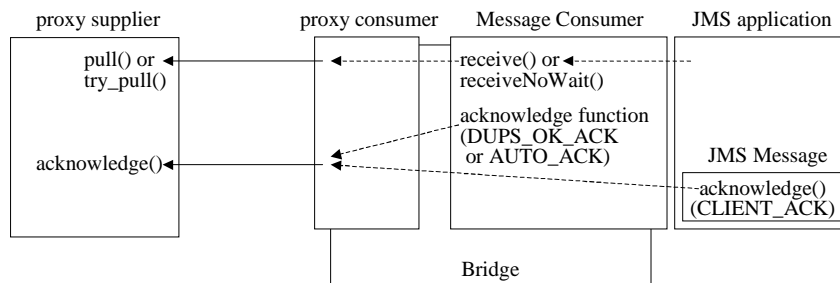

Figure 2-9 Synchronous delivery mapping

In the synchronous delivery mapping, when the JMS MessageConsumer works with DUPS\_OK\_ACKNOWLEDGE or AUTO\_ACKNOWLEDGE mode, the Bridge as Notification Service consumer sets the value of SequenceNumber header field of received event (or event batch) to the SequenceNumbers input parameter and invokes acknowledge operation whenever an event is received.

In the synchronous delivery mapping, when the JMS MessageConsumer works with CLIENT\_ACKNOWLEDGE mode, the Bridge as Notification Service consumer sets one or more values of SequenceNumber header field of received events (or event batches) to the SequenceNumbers input parameter and invokes acknowledge operation only when the JMS application calls the acknowledge method of the JMS MessageObject.

In the asynchronous or the synchronous delivery, when Notification Service's Event Acknowledgment is applied for mapping of JMS Message Acknowledgment, following conditions must also be satisfied to apply combination 4 of the related QoS properties (see Section 4.2.8.1, "DeliveryReliability," on page 4-13):

- the EventReliability QoS property is set to Persistent, and
- the ConnectionReliability QoS property is set to Persistent.

---

**Note** – When the Notification Service push model is mapped with the JMS DUPS\_OK\_ACKNOWLEDGE or AUTO\_ACKNOWLEDGE mode, invoking acknowledge operation is actually not needed. Because the supplier can know that sent event reached the consumer by the end of push operation. However when the push model is mapped with the JMS CLIENT\_ACKNOWLEDGE mode, the end of push operation can't be used for the purpose. Because in the JMS CLIENT\_ACKNOWLEDGE mode, JMS application notifies of receipt of an event by an acknowledgment explicitly.

---

This difference between DUPS\_OK\_ACKNOWLEDGE/AUTO\_ACKNOWLEDGE and CLIENT\_ACKNOWLEDGE makes design of supplier complex. So the specification forces consumer to invoke acknowledge operation to remove the difference between DUPS\_OK\_ACKNOWLEDGE/AUTO\_ACKNOWLEDGE and CLIENT\_ACKNOWLEDGE from the viewpoint of supplier for simple design of supplier.

## 2.7 *Transactional Support*

### 2.7.1 *Asynchronous Transactional Model*

To maintain the transaction semantic from a Notification Service client to a JMS client, at least three different transactions are needed:

1. One transaction (T1) that involves a notification client, its transactional resources (e.g., a database) and the notification service.
2. One transaction (T2) that involves the Notification Service, the bridge and the JMS implementation. This transaction will be named Routing transaction.

- One transaction (T3) that involves a JMS client, its transactional resources (e.g., a database) and the JMS implementation.

These transactions are tied by precedence rules. When Sending an event from an event supplier to a JMS consumer the precedence rules imply that:

- The transaction T3 will start only and only if T2 commits.
- T2 will start only and only if T1 commits.
- Each time one of these transactions commits the data sent in its scope is moved toward its next destination.
- If one of those transactions rolls back, the data sent in its scope will be put back into its initial destination. Subsequent trials will take place to send the data to its next destination later.

These rules imply that once data is sent from the supplier, it will be conveyed to its final destination that is the consumer, guaranteeing the transaction semantic from end-to-end.

When Sending a JMS message from a JMS sender (or publisher) to an event consumer the precedence rules are reversed, meaning that T1 will not take place only and only if T2 commits and T2 will not take place only and only if T3 commits.

Although the usage of end-to-end transaction semantic is recommended this specification does not mandate it. This specification covers the routing transaction (T2) only which implies that a notification service client can send or receive events in a non-transactional context, likewise the JMS client can send or receive JMS messages in a non-transactional context, but the data sent between notification service and JMS may be sent in the routing transaction context.

The rationale behind the use of the routing transaction without necessarily using transactions at the Notification Service and JMS client sides is that the Notification Service to JMS communication portion is hidden and transparent to the application client developers preventing them from performing any recovery action if a failure, that will lead to data loss, occurs.

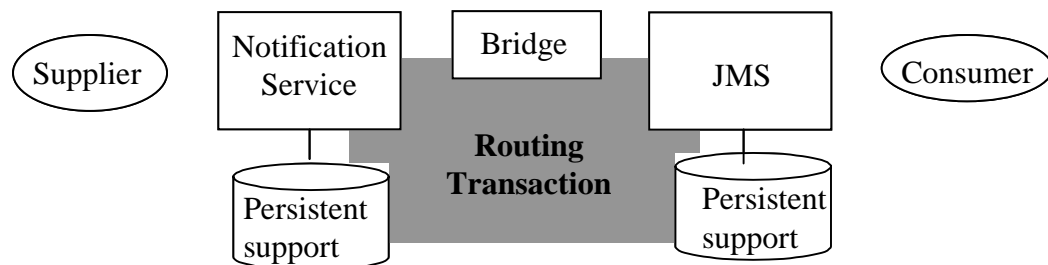

Figure 2-10 Routing Transaction Scope

To guarantee the ACID transactional properties of the Routing Transaction it is expected that the notification service and the JMS implementation rely on a transactional persistent support.

Applying end-to-end transaction semantic and using transactional persistent support in an effective way will guarantee the exactly-once delivery QoS.

Figure 2-10 denotes the Routing transaction scope. This transaction involves the bridge, the Notification Service, the JMS service provider, and the Persistent Supports used by them. All those components should be coordinated by a single root coordinator which is hosted by a Transaction Service.

It is also expected that the interposition schema is applied between OTS (Object Transaction Service) on the CORBA side and JTS (Java Transaction Service) on the Java side. The interoperability between OTS and JTS is guaranteed by the fact that JTS is mapped from OTS and its usage of IIOP as an underlying transport protocol to propagate transaction context between OTS and JTS.

Both JMS and Notification specifications provide a model that outlines how a messaging system should behave in a transactional environment. The transactional roles of the JMS, the Bridge and the Notification Service are driven by the following considerations:

- The Notification Service specification allows a channel and its related proxy objects to initiate a transaction and assumes the transaction client role.
- The Notification Service specification allows a channel and its related proxy queue objects to assume the Resource object role.
- The JMS service provider doesn't support the transactional client role.
- The Bridge should be as light as possible, meaning that it should not be assigned complex transactional behaviors. This assertion will promote the bridge adoption by the industry.

### 2.7.2 *Supported configurations*

By combining the communication consistency checking defined in Table 2-1 and the state of the art of the transactional role of JMS and Notification, the only case where events can be sent from Notification service to JMS in transaction scope is the case where the Channel pushes the data to the bridge and the bridge pushes it to JMS. Likewise, the only case where data can be sent from JMS to Notification service in transaction scope is the case where the Channel pulls data from the bridge that will synchronously pull it from JMS.

In both cases the Notification Service assume the Routing Transaction client role.

The Figure 2-11 summarizes the supported transactional configurations. The Transactional Roles of different components are detailed in the next sections.

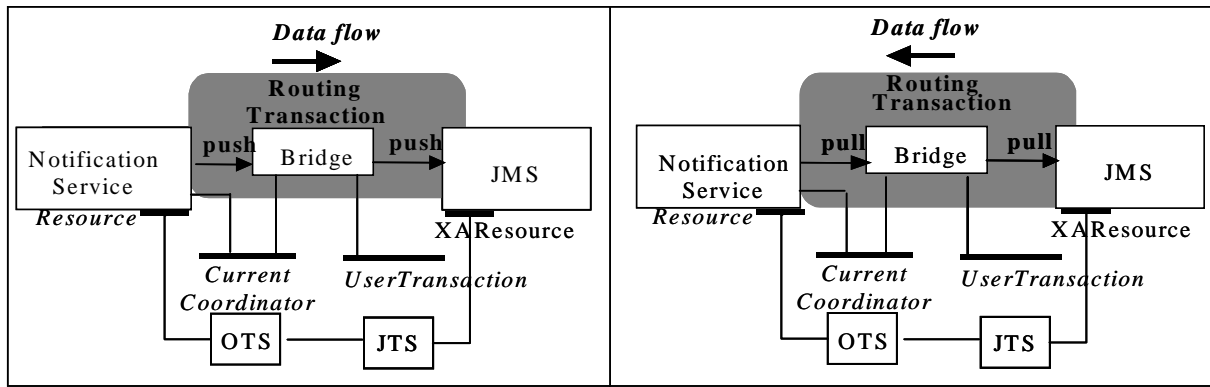

Figure 2-11 Supported transactional configuration

### 2.7.3 Notification Service Transactional Role

When events are sent in the routing transaction scope, the Notification Service assumes always the transaction client and recoverable server roles, and as such the Notification Service: Starts a transaction may use the OTS Current interface; Enlist a Resource object that wraps events queues using the OTS Coordinator interface.

The notification service may also use direct transactional context management, by using the OTS Control interface, to manage the routing transaction.

The Notification Service queue managers participate into the two-phase commit completion and the recovery protocols by implementing the Resource Object interface and the transactional recovery protocol as it is specified in the OTS specification. The behavior of the Notification Service Resource Objects depends on whether the Notification Service is the source or the sink of the data.

#### 2.7.3.1 Data Flowing from Notification Service to JMS

When the Notification Service sends one or several events in to the routing transaction scope, the OTS transaction identifier is propagated implicitly to JTS in the Propagation context.

If the events are sent successfully the Notification Service asks the Transaction Service to commit the routing transaction. When the root transactional coordinator decides definitively to commit the routing transaction the events associated to it are removed from Notification Service events queue.

If the events were not correctly sent or if the root transactional coordinator rolls back the routing transaction for any other reason, the events sequences associated with it will remain in events queue, these events will be sent later when the notification service will start a new transaction.

### *2.7.3.2 Data flowing from JMS to Notification Service*

When the Notification Service receives one or several events in to the routing transaction scope, the OTS transaction identifier is propagated implicitly to JTS in the Propagation context.

If all the events are received and stored into the transactional persistent support successfully the Notification Service asks the Transaction Service to commits the routing transaction. When the root transactional coordinator decides definitively to commit the routing transaction the events associated to it are durably added in to the Notification Service events queue.

If the events were not correctly received or if the root transactional coordinator rolls back the routing transaction for any other reason, the events that are potentially received in its scope will be deleted from the events queue.

### *2.7.4 Bridge Transactional Roles*

In order to keep the bridge simple, one design principle was to forbid attributing to it the transaction client role. Furthermore, this specification does not define any recoverable state and does not implement any transactional change at the Bridge level.

The bridge does not participate to the transaction completion protocol, but it can force the transaction roll back. A typical case is when the bridge is unable to carry the data to the JMS or to the Notification Service. To rollback the transaction the bridge may use either the JTA/JTS or OTS interfaces. Therefore, the bridge is assuming the transactional object role.

### *2.7.5 JMS service provider Transactional Role*

The JMS specification does not attribute any transaction client role, meaning that the JMS service provider is not allowed to initiate or start any transaction.

The JMS specification assigns to JMS a Resource Manager role, meaning that it can integrate the sphere of control of the routing transaction by enlisting its transactional queue manager using the `javax.transaction.Transaction` interface and implements the transactional semantic on the message queues. The JMS queue managers participate into the two-phase commit completion and the recovery protocols by implementing the `javax.transaction.xa.XAResource`, `javax.jms.XAConnection` and the `javax.jms.XASession` interfaces and the transactional recovery behavior as it is specified in the JTA specification.

The behavior of JMS XAResource objects depends on whether the JMS Service is the source or the sink of the data.



### *2.7.5.1 Data Flowing from Notification Service to JMS*

Due to the considerations described in Section 2.7.2, “Supported configurations,” on page 2-24 only the notification service is the component that is allowed to initiate routing transactions. When the Notification Service sends successfully events that are translated to messages to JMS and commits the routing transaction all the messages are durably stored in the JMS message queues and the transactional persistent support.

If the messages were not correctly sent or if the root transactional coordinator rolls back the routing transaction for any other reason the messages are potentially sent in the routing transaction scope will be removed from the JMS message queue and the transactional persistent support. The messages will be received later when the notification service will start a new transaction.

### *2.7.5.2 Data Flowing from JMS to Notification Service*

When the bridge pulls JMS in to the scope of the routing transaction the OTS transaction identifier is propagated implicitly to JTS in the Propagation context. The propagation context will be in turn propagated to the JMS XAResource Object that encapsulates the message queues.

If the JMS returns successfully the messages in to the routing transaction scope and if the notification service receives them successfully the Notification Service asks the Transaction Service to commits the routing transaction. When the root transactional coordinator decides definitively to commit the routing transaction the events associated to the routing transactions are durably removed from the JMS message queue.

If the translated messages to events were not correctly received into the notification service or if the root transactional coordinator rolls back the routing transaction for any other reason, the messages that are potentially sent in the routing transaction scope will remain in the JMS message queue.

## *2.7.6 Bridge Transactional Monitoring*

### *2.7.6.1 Notification Service QoS and Admin Property Extensions*

The notification service specification states that in order to support transactional event transmission, an implementation of the Notification Service should support implementations of the various proxy interfaces that are POA objects that support TransactionPolicy. Unfortunately the specification was not precise enough to define the way an application program will dynamically control the transactionality of its proxy in the notification service. Furthermore, the specification did not offer to the developer the way to specify the number of events that are sent or retrieved by the event channel in the scope of a transaction. To make up for those gaps we propose to extend the Notification Service quality of services and administration properties Framework by a new QoS and three administrative properties.

Fortunately, the Notification Service QoS and Admin frameworks are flexible enough to add new QoS and AdminProperty values without changing the Notification Service interfaces. Therefore the new QoS and AdminProperties should be seen as an extension rather than a modification of the Notification Service Interfaces. These new QoS and AdminProperties are:

- EnableTransaction QoS is a boolean that enables the notification service client to activate or deactivate the support of the transaction at Notification Service object levels. When this QoS is enabled and applied on the ProxyPushSupplier, ProxyPullConsumer, StructuredProxyPushSupplier, StructuredProxyPullConsumer, and TypedProxyPushSupplier, TypedProxyPullConsumer7 levels it will allow the later to behave as a transaction client. When this QoS is disabled and applied on those various types of proxy their transactional client behavior is disabled. This is their default behavior. When the EnableTransaction QoS is enabled at the ProxyPushConsumer, ProxyPullSupplier, StructuredProxyPushConsumer, StructuredProxyPullSupplier TypedProxyPushConsumer, and TypedProxyPullSupplier7, the proxies' implementations will set their TransactionalPolicy to Require\_shared. By default this QoS is disabled, meaning that for the ProxyPushConsumer various types and the ProxyPullSupplier various types the proxies' POAs TransactionalPolicy attributes are set to Allows\_none.

If this QoS is applied at the SupplierAdmin, ConsumerAdmin, TypedSupplierAdmin7 or TypedConsumerAdmin7 levels each of their proxy child will enable individually this QoS at their level according to their types. If this QoS is applied at the channel, respectively TypedChannel7 level all the SupplierAdmin and the ConsumerAdmin, respectively, all the TypedSupplierAdmin and the TypedConsumerAdmin objects will enable this QoS, subsequently all the proxy objects apply it individually.

Whenever the EnableTransaction QoS is enabled the EventReliability and the ConnectionReliability QoSs will be setup automatically by the Notification Service to "Persistent". Likewise, when this QoS is disabled the EventReliability and the ConnectionReliability are set to "BestEffort".

- TransactionEvents AdminProperty defines the number of separate events sent in the scope of a transaction. The scope of this property is the ProxyPushSupplier, ProxyPullConsumer, StructuredProxyPushSupplier, StructuredProxyPullConsumer, TypedProxyPushSupplier, and TypedProxyPullSupplier.
- TransactionEventSequences AdminProperty defines the number of event sequences sent in the scope of a transaction. The scope of this property is the SequenceProxyPushSupplier and SequenceProxyPullConsumer.
- TransactionTimeout adminProperty defines the timeout period in number of seconds associated with routing transaction created. If the parameter has a non-zero value n, then the created routing transaction will be subject to being rolled back if they do not complete before n seconds after their creation. If its value is zero, then no application specified time-out is established. This adminProperty is aimed to be mapped on the unsigned long input parameter of the OTS Current.set\_timeout() operation. This adminProperty is applied on all the proxies that behave as transaction clients.

When those adminProperty are applied at the SupplierAdmin, ConsumerAdmin or EventChannel level they will affect only the proxies with transaction client behavior. Table 2-10 summarizes the scope of the new QoS and AdminProperties at the proxy level. It also summarizes proxies' transactional roles. Empty Cells denotes that QoS is not applicable.

Table 2-10 New Notification Service QoS and AdminProperties scope

	Proxy Types	QoS	AdminProperties		
		Enable Transaction	Transaction Timeout	Transaction EventSequences	Transaction Events
TransactionClientRole	ProxyPushSupplier,	X	X		X
	ProxyPullConsumer,	X	X		X
	StructuredProxyPushSupplier	X	X		X
	StructuredProxyPullConsumer	X	X		X
	SequenceProxyPushSupplier	X	X	X	
	SequenceProxyPullConsumer	X	X	X	
	TypedProxyPushSupplier7,	X	X		X
	TypedProxyPullConsumer7	X	X		X
Transaction Server Role	ProxyPushConsumer	X			
	ProxyPullSupplier	X			
	StructuredProxyPushConsumer	X			
	StructuredProxyPullSupplier	X			
	SequenceProxyPushConsumer	X			
	SequenceProxyPullSupplier	X			
	TypedProxyPushConsumer7	X			
	TypedProxyPullSupplier7	X			

### 2.7.6.2 Bridge Transaction Management Interface

The TransactionManagement interface provides the bridge application clients the ability to enable and disable automatically the routing transactions. This interface is optionally inherited by the Bridge interface.

This interface contains two operations: enable\_transaction( ) and disable\_transaction( ).

The invocation of the enable\_transaction operation will enable the proxies with a transaction client behavior (StructuredProxyPushSuppliers, StructuredProxyPullConsumer, SequenceProxyPushSupplier, SequenceProxyPullConsumer) to start routing transactions and manage their events queues as OTS recoverable objects. It also enables the bridge EndPoint objects that are connected to the notification service to set their Transactional POA Policies to Require\_shared. The EndPoint objects affected by this operation are:

- StructuredPushConsumer
- SequencePushConsumer
- StructuredPullSupplier
- SequencePullSupplier

This operation takes as an input the number of events sent in the scope of the routing transaction and the routing transaction lifetime.

The invocation of the `disable_transaction` operation will disable subsequent routing transactions.

## 2.8 Conformance

The Transaction mapping capabilities, specified in Section 2.7, are an optional conformance point for this specification. All other interfaces defined in this specification are required to be implemented for conformance to this specification.

A conforming implementation of this interworking specification, as a supplier, must also support, in addition to the mandatory interfaces of the OMG Notification Service, all of the interfaces defined in the `CosNotifyCommAck` module.

A conforming implementation of this interworking specification, as a proxy supplier, must also support, in addition to the mandatory interfaces of the OMG Notification Service, all of the interfaces defined in the `CosNotifyChannelAdminAck` module,

This chapter describes the semantic and the behavior of the interfaces which make up the NS-JMS bridge. All the data structures and the interfaces are defined in the CoSBridgeAdmin module.

### 3.1 CosBridgeAdmin Module

The **CosBridgeAdmin** module defines the **ExternalEndPoint** data type, along with EndPointSender and EndPointReceiver types. In addition, this module provides declarations for administrative interfaces which are defined for managing the Bridge Life cycle.

```
#ifndef _COS_BRIDGE_ADMIN_
#define _COS_BRIDGE_ADMIN_

#include <CosNotifyComm.idl>
#include <CosNotifyChannelAdmin.idl>
#include <CosNotifyChannelAdmin.idl>
#include <CosEventDomainAdmin.idl>
#include <MessageListener.idl>

#pragma prefix "omg.org"

module CosBridgeAdmin
{
    enum ExternalEndpointRole
    {
        SOURCE,
        SINK
    };

    enum JMSDestinationType
    {
        QUEUE,
        TOPIC
    }
}
```

```
};

enum MessageType
{
    JMS_MESSAGE,
    STRUCTURED_EVENT,
    SEQUENCE_EVENT
};

struct JMSDestination
{
    JMSDestinationType destination_type;
    string destination_name;
    string factory_name;
};

union ExternalEndpointConnector switch (MessageType)
{
    case JMS_MESSAGE: JMSDestination destination;
    default: CosNotifyChannelAdmin::ChannelID channel_id;
};

struct ExternalEndpoint
{
    ExternalEndpointRole role;
    ExternalEndpointConnector connector;
    CosEventDomainAdmin::NotificationStyle style;
    MessageType type;
};

enum ExternalEndpointErrorCode
{
    INVALID_CHANNELID,
    INVALID_JMSDESTINATION,
    MISMATCH_ENDPOINTROLE_NOTIFSTYLE
};

struct ExternalEndpointError
{
    ExternalEndpointRole role;
    ExternalEndpointErrorCode code;
};

typedef sequence<ExternalEndpointError> ExternalEndpointErrorSeq;

exception InvalidExternalEndPoints
{
    ExternalEndpointErrorSeq error;
};

typedef long BridgeID;
typedef sequence<BridgeID> BridgeIDSeq;

exception BridgeAlreadyStarted {};
exception BridgeInactive {};
```

```
exception BridgeNotFound {};  
  
enum status  
{  
    stopped,  
    started  
};  
  
enum EndpointReceiverType  
{  
    STRUCTURED_PUSH_CONS,  
    SEQUENCE_PUSH_CONS,  
    STRUCTURED_PULL_CONS,  
    SEQUENCE_PULL_CONS,  
    MESSAGE_LISTENER,  
    MESSAGE_CONSUMER  
};  
  
union EndpointReceiver switch (EndpointReceiverType)  
{  
    case STRUCTURED_PUSH_CONS: CosNotifyComm::StructuredPushConsumer  
        structured_push_consumer;  
    case SEQUENCE_PUSH_CONS: CosNotifyComm::SequencePushConsumer  
        sequence_push_consumer;  
    case STRUCTURED_PULL_CONS: CosNotifyComm::StructuredPullConsumer  
        structured_pull_consumer;  
    case SEQUENCE_PULL_CONS: CosNotifyComm::SequencePullConsumer  
        sequence_pull_consumer;  
    case MESSAGE_LISTENER: javax::jms::MessageListener  
        msg_listener;  
};  
  
enum EndpointSenderType  
{  
    STRUCTURED_PUSH_SUPL,  
    SEQUENCE_PUSH_SUPL,  
    STRUCTURED_PULL_SUPL,  
    SEQUENCE_PULL_SUPL,  
    MESSAGE_PRODUCER  
};  
  
union EndpointSender switch (EndpointSenderType)  
{  
    case STRUCTURED_PUSH_SUPL: CosNotifyComm::StructuredPushSupplier  
        structured_push_supplier;  
    case SEQUENCE_PUSH_SUPL: CosNotifyComm::SequencePushSupplier  
        sequence_push_supplier;  
    case STRUCTURED_PULL_SUPL: CosNotifyComm::StructuredPullSupplier  
        structured_pull_supplier;  
    case SEQUENCE_PULL_SUPL: CosNotifyComm::SequencePullSupplier  
        sequence_pull_supplier;  
};  
  
interface BridgeFactory;
```

```

interface Bridge
{
    readonly attribute EndpointReceiver end_point_receiver;
    readonly attribute EndpointSender end_point_sender;

    void start () raises (BridgeAlreadyStarted);
    void stop () raises (BridgeInactive);
    status get_status();
    void destroy ();
};

interface BridgeFactory
{
    Bridge create_bridge (in ExternalEndpoint source, in ExternalEndpoint sink, out
BridgeID id)
        raises (InvalidExternalEndPoints );
    Bridge get_bridge_with_id (in BridgeID id)
        raises (BridgeNotFound);
    BridgeIDSeq get_all_bridges();
};
}; // CosBridgeAdmin

#endif

```

### 3.1.1 ExternalEndPoint

ExternalEndPoints are abstract entities that represent the sender and the receiver of the data through the NS-JMS bridge. These entities are represented by a data structure ExternalEndPoint which specifies:

1. The role of the external end point which can be either a Source or a Sink of data.
2. The nature of the external end point, be it a JMS destination or an EventChannel.
3. The Notification style used by the ExternalEndPoint, which can be either a Push or a Pull.
4. The type of message that it handles. This type can be either a JMS message, a structured event or a sequence of the structured events.

Each of the previous points is described by an ExternalEndPoint field in the structure. The following subsections describe briefly those fields.

#### 3.1.1.1 ExternalEndpointRole

The ExternalEndpointRole is an enumeration that describes the role of the ExternalEndPoint. The enumeration is made by the following values: {SOURCE, SINK};



### 3.1.1.2 *ExternalEndpointConnector*

The `ExternalEndpointConnector` is an IDL union structure that represents exclusively a `JMSDestination` or an `EventChannel`. If the `ExternalEndpointConnector` handles a `JMS_MESSAGE` message type it refers to a `JMSDestination`. If it handles a structured event or a sequence of structured events it refers to an `EventChannel`.

The `JMSDestination` is a data structure that includes :

1. The `JMSDestinatonType`, which is an enumeration that can be either a `Queue` or a `Topic`,
2. a string that specifies the destination name,
3. a string that specifies the JMS factory name.

The `EventChannel` is represented by its identifier, the **`CosNotifyChannelAdmin::ChannelID`**.

### 3.1.1.3 *MessageType*

The `MessageType` specifies the type of messages that can be processed by the bridge. The `MessageType` is an enumeration that can be either a `JMS_MESSAGE`, a `STRUCTURED_EVENT`, or `SEQUENCE_EVENT`.

## 3.1.2 *EndPointSender interface*

The `EndPointSender` interface connects and fits the `ExternalEndPoint` type when the later behaves as data Consumer. The `EndPointSender` behaves as data supplier. Depending on the values of the **`CosEventDomainAdmin::NotificationStyle`** and the `MessageType` fields, the `EndPointSender` can be either:

1. **`CosNotifyComm::StructuredPushSupplier`** if the **`CosEventDomainAdmin::NotificationStyle`** and the `MessageType` of the `ExternalEndPoint` values are respectively `PUSH` and `STRUCTURED_EVENT`. This means that the `EndPointSenderType` is `STURCTURED_PUSH_SUPPLIER`.
2. **`CosNotifyComm::SequencePushSupplier`** if the **`CosEventDomainAdmin::NotificationStyle`** and the `MessageType` of the `ExternalEndPoint` values are respectively `PUSH` and `SEQUENCE_EVENT`. This means that the `EndPointSenderType` is `SEQUENCE_PUSH_SUPPLIER`.
3. **`CosNotifyComm::StructuredPullSupplier`** if the **`CosEventDomainAdmin::NotificationStyle`** and the `MessageType` of the `ExternalEndPoint` values are respectively `PULL` and `STRUCTURED_EVENT`. This means that the `EndPointSenderType` is `STRUCTURED_PULL_SUPPLIER`.
4. **`CosNotifyComm::SequencePullSupplier`** if the **`CosEventDomainAdmin::NotificationStyle`** and the `MessageType` of the `ExternalEndPoint` values are respectively `PULL` and `SEQUENCE_EVENT`. This means that the `EndPointSenderType` is `SEQUENCE_PULL_SUPPLIER`.

When the **CosEventDomainAdmin::NotificationStyle** value is PUSH and the Message**Type** is JMS\_MESSAGE the EndPointSender behaves as JMS producer. According to the JMS specification, the JMS producer does not offer any interface.

The EndPointSenderType value MESSAGE\_PRODUCER is specified for a future usage if the JCP community decides to extend the JMS PushSupplier with a new interface.

### 3.1.3 EndpointReceiver interface

The EndPointReceiver interface connects and fits the ExternalEndPoint type when the later behaves as a data supplier. The EndPointReceiver behaves as data consumer. Depending on the values of the **CosEventDomainAdmin::NotificationStyle** and the Message**Type** fields, the EndPointReceiver can be either a

1. **CosNotifyComm::StructuredPushConsumer** if the **CosEventDomainAdmin::NotificationStyle** and the Message**Type** of the ExternalEndPoint values are respectively PUSH and STRUCTURED\_EVENT. This means that the EndPointReceiverType is STURCTURED\_PUSH\_CONSUMER.
2. **CosNotifyComm::SequencePushSupplier** if the **CosEventDomainAdmin::NotificationStyle** and the Message**Type** of the ExternalEndPoint values are respectively PUSH and SEQUENCE\_EVENT. This means that the EndPointReceiverType is SEQUENCE\_PUSH\_CONSUMER.
3. **CosNotifyComm::StructuredPullSupplier** if the **CosEventDomainAdmin::NotificationStyle** and the Message**Type** of the ExternalEndPoint values are respectively PULL and STRUCTURED\_EVENT. This means that the EndPointReceiverType is STURCTURED\_PULL\_CONSUMER.
4. **CosNotifyComm::SequencePullSupplier** if the **CosEventDomainAdmin::NotificationStyle** and the Message**Type** of the ExternalEndPoint values are respectively PULL and SEQUENCE\_EVENT. This means that the EndPointConsumerType is SEQUENCE\_PULL\_CONSUMER.
5. MessageListener JMS standard interface, if the EndPointConsumerType is the **CosEventDomainAdmin::NotificationStyle** and the Message**Type** values of the ExternalEndPoint are respectively PUSH and JMS\_MESSAGE. EndPointConsumerType corresponds to MESSAGE\_LISTENER.

When the **CosEventDomainAdmin::NotificationStyle** value is PULL and the Message**Type** is JMS\_MESSAGE the EndPointReceiver behaves as JMS Consumer. According to the JMS specification, the JMS consumer that pulls messages does not offer any interface.

The EndPointReceiverType value's MESSAGE\_CONSUMER is specified for a future usage if the JCP community decides to extend the JMS PullConsumer with a new interface.

### 3.1.4 Bridge Interface

The Bridge interface encapsulates the behaviors supported by a NS-JMS bridge instance.

Each instance of the Bridge interface has two readonly attributes: EndPointSender, EndPointReceiver both of them exist upon creation of the bridge. Due to the architectural restriction described in Section 2.3, "Bridge Instance," on page 2-4 this interface does not allow the creation of new Endpoint instances.

The Bridge interface supports operations that:

1. activates the Bridge instance to start forwarding and transforming data,
2. deactivates the Bridge instance,
3. obtains the status of the bridge for the administration purposes,
4. destroys the Bridge instance.

#### 3.1.4.1 *start*

The start operation activates the bridge in order to receive and forward data. This operation maps on the Proxy's connect\_ operation on the Notification Service side and on the javax.jms.Connection.start operation on the JMS side to initiate the JMS Connection's delivery of incoming messages.

When the start operation is successfully executed the bridge state becomes started. Restarting an already started bridge raises the **BridgeAlreadyStarted** exception.

#### 3.1.4.2 *stop*

When a Bridge is created it is in stopped mode.. The stop operation deactivates the bridge. That means that no messages are being delivered to it. This operation maps on the Proxy's disconnect\_ operation on the Notification Service side and on the javax.jms.Connection.stop operation on the JMS side.

When the stop operation is successfully executed the bridge state becomes stopped. Stopping an inactive bridge raises the BridgeInactive exception.

#### 3.1.4.3 *get\_status*

The get\_status operation returns the current state of the bridge which can be either in stopped or in a started mode. The state of the bridge is not necessarily persistent.

#### 3.1.4.4 *destroy*

The destroy operation destroys the Bridge instance. The EndPointReceiver and EndPointSender implementations invoke the disconnect operation on the corresponding Notification Service and invoke the stop operation on the JMS side. When those operations are successfully executed both of the end points are destroyed.

### 3.1.5 Bridge Factory Interface

A BridgeFactory is responsible for the creation of Bridge objects based on initial parameters. In order to create a bridge, it is necessary to have the identifier of an existing Notification Service event channel and a JMS destination information.

#### 3.1.5.1 create\_bridge

The create\_bridge operation creates new instances of NS-JMS bridge. At creation time, the client must specify two external points. One external point must represent an EventChannel Instance the other one must represent a JMS destination. Furthermore, the external points information must be consistent with the communication consistency checking table defined in Section 2.2, “Bridge Factory,” on page 2-3. For example, connecting an external point behaving as an EventChannel, assuming the Source role and using the PUSH NotifyStyle with an external point behaving as a JMSDestination, assuming the Sink role and using the PULL NotifyStyle is not consistent.

The create\_bridge operation raises the **InvalidExternalEndpoints** exception when an inconsistent external endpoint is passed as input parameters.

If no exception is raised, the create\_bridge operation will return a reference to a new bridge and will assign to this new bridge a unique numeric identifier. This identifier is returned as an output parameter.

#### 3.1.5.2 get\_all\_bridges

The get\_all\_bridges operation returns a sequence of all of the unique numeric identifiers corresponding to NS-JMS bridge instances, which have been created by the Bridge factory.

#### 3.1.5.3 get\_bridge\_with\_id

The get\_bridge\_with\_id operation returns a reference to the Bridge object identified by the supplied bridge id. If the bridge cannot be found, then the **BridgeNotFound** exception is thrown.

## 3.2 BridgeTransactionMgmt module

The BridgeTransactionMgmt module defines a single TransactoinManagement interface.

### 3.2.1 TransactionManagement interface

The TransactionManagement interface is optionally inherited by the Bridge interface. It manages the activation and the disactivation of the routing transaction. This interface is made up by two operations: enable\_transaction and disable\_transaction.

```
module BridgeTransactionMgmt  
{
```

```

exception UnsupportedTransaction {};
exception TransactionAlreadyActive {};
exception TransactionActive {};

interface TransactionManagement
{
    void enable_transaction (in unsigned long events, in unsigned long tim-
out)
    raises (UnsupportedTransaction, TransactionAlreadyActive);
    void disable_transaction() raises (TransactionActive);
};
}; // BridgeTransactionMgmt

```

### 3.2.1.1 *enable\_transaction*

The `enable_transaction` operation configures the proxies, namely the `StructuredProxyPushSuppliers`, `StructuredProxyPullConsumer`, `SequenceProxyPushSupplier`, `SequenceProxyPullConsumer` with a transactional client behavior. It allows also those proxies to manage their events queues as OTS recoverable objects.

This operation sets `EnableTransaction` new Notification Service QoS to true. It configures the bridge EndPoint objects, namely the `StructuredPushConsumer`, `SequencePushConsumer`, `StructuredPullSupplier`, `SequencePullSupplier` that are connected to the notification service to set their Transactional POA Policies to `Require_shared`.

This operation takes as an input parameter the number of events sent in the scope of the routing transaction. When the bridge convey event sequences, this input parameter denotes the number of event sequences, meaning that the total number of events sent in the routing transaction scope is obtained by multiplying the number of events within a sequence by the value of the input parameter. The number of events, respectively, the number of event sequences sent in the scope of the routing transaction are mapped on the new notification service `TransactionEvents`, respectively, `TransactionEventSequences` AdminProperties.

The `enable_transaction` operation takes also as an input parameter the lifetime of the routing transaction. The lifetime of the routing transaction is mapped on the Notification Service `TransactionTimeout` AdminProperty.

This operation raises the `UnsupportedTransaction` exception if the Notification Service or the JMS Implementations does not support distributed transactions.

It raises the Exception `TransactionAlreadyActive` if an active transaction is already associated to the bridge object.

### 3.2.1.2 *disable\_transaction*

The `disable_transaction` operation invocation disables the bridge, the notification service and the JMS transactional behaviors. Invoking this operation on an in progress transaction will raise an exception `TransactionActive` and it will disable the subsequent routing transaction from taking place. The actual execution of this operation will take place as soon as the active transaction finishes.

The implementation of the `disable_transaction` will configure the bridge `EndPoint` objects, namely the `StructuredPushConsumer`, `SequencePushConsumer`, `StructuredPullSupplier`, `SequencePullSupplier` to set their Transactional POA Policies to `Allows_none`. It will also set the Notification Service `EnableTransaction QoS` to `False`.

# *Extension to Existing OMG Specifications*

---

This specification adds two new modules defined in a new subsection of the OMG Notification Service. Support for each of these two new modules forms a new optional conformance point for the Extended Notification Service.

## *4.1 Editing Instructions for Extended Notification Service*

The following text (new text is in outline format) needs to replace the compliance clause in the notification service subsection 1.2.1 :

"

In order to be conformant with this specification, all of the interfaces must be supported and implemented using the specified semantics, with the exception of the interfaces for typed notification channels, which are optional. In addition, a conforming implementation must support filter objects that support constraints expressed in the default constraint grammar defined in Section 2.4, "The Default Filter Constraint Language," on page 2-23. Lastly, this document defines a set of standard QoS properties, which must at least be understood (although not necessarily implemented) by all conformant implementations.

More precisely,

- A conforming implementation must support all interfaces defined in the
  - CosNotification, CosNotifyFilter, CosNotifyComm, and
  - CosNotifyChannelAdmin modules.
- A conforming implementation may also support, in addition to the mandatory interfaces enumerated above, all of the interfaces defined in the
  - CosTypedNotifyChannelAdmin module.
- A conforming implementation may also support, in addition to the mandatory interfaces enumerated above, all of the interfaces defined in the
  - CosNotifyChannelAdminAck module,

- A conforming implementation may also support, in addition to the mandatory interfaces enumerated above, all of the interfaces defined in the
  - CosNotifyCommAck module,
- A conforming implementation will provide implementations of the
  - CosNotifyFilter::Filter and CosNotifyFilter::MappingFilter interfaces that support constraints expressed in the default constraint grammar specified in Section 2.4, "The Default Filter Constraint Language," on page 2-23.
- All QoS properties defined in Chapter 2 and 3.7 of this specification, must at least be understood by any conforming implementation. However, a conforming implementation may choose to not implement all standard QoS properties and/or QoS property settings. In cases where a client requests a standard QoS property with a setting that is not supported by a conformant implementation, the implementation should raise the CosNotification::UnsupportedQoS exception.

"

Insert the following section 4.2 as a new section 3.7 (with appropriate renumbering) of the OMG Notification Service.

Insert, also, the section 4.3 as a new subsection section 2.1.5 (Sending Events within a Transaction) of the OMG Notification Service.

## 4.2 IDL Modules

This subsection specifies two IDL modules, CosNotifyCommAck and CosNotificationChannelAdminAck, for Notification acknowledgement.

The IDL behavior required for support and use of the interfaces in these two modules, including:

- sender including a sequence number field in the structured notification, with the parameter name "SequenceNumber";
- behavior of the "acknowledge" operation;
- the message retry sequence; and
- new QOS parameters associated with these ack interfaces

is specified in this subsection.

### 4.2.1 The CosNotifyCommAck Module

To provide a SequenceNumber and an explicit acknowledgement to invoke on Push and Pull supplier interfaces, the module, Cos Notify Comm Ack, is defined.

Support of its interfaces, which extend the structuredxxxSupplier, and the sequenceStructuredxxxSupplier interfaces by adding a single "acknowledge" operation, is subject to an optional conformance point.



```

//File: CosNotifyCommAck.idl
//Part of the extended Notification Service
#ifndef _COS_NOTIFY_COMM_ACK_IDL_
#define _COS_NOTIFY_COMM_ACK_IDL_
#include <CosNotifyComm.idl>
#pragma prefix "omg.org"

module CosNotifyCommAck {
const string SequenceNumber = "SequenceNumber";
// SequenceNumber takes a value of type long.
// Structured events must include a SequenceNumber field to be acknowledged

typedef sequence<long> SequenceNumbers;

const string DeliveryReliability = "DeliveryReliability";
const short None = 0;
const short Acknowledgment = 1;
// DeliveryReliability takes value of None or Acknowledgement as Notification Qos

const string RetryInterval = "RetryInterval";
// RetryInterval takes on a value of TimeBase::TimeT as Notification Qos

const string Retries = "Retries";
// Retries takes on a value of type long as Notification Qos Parameter

interface StructuredPushSupplierAck : CosNotifyComm::StructuredPushSupplier {
void acknowledge(in SequenceNumbers sequence_numbers);
};

interface StructuredPullSupplierAck : CosNotifyComm::StructuredPullSupplier {
void acknowledge(in SequenceNumbers sequence_numbers);
};

interface SequencePushSupplierAck : CosNotifyComm::SequencePushSupplier {
void acknowledge(in SequenceNumbers sequence_numbers);
};

interface SequencePullSupplierAck : CosNotifyComm::SequencePullSupplier {
void acknowledge(in SequenceNumbers sequence_numbers);
};
};
#endif

```

#### 4.2.2 The *CosNotifyChannelAdminAck* Module

To provide explicit acknowledgement in proxy interfaces, the Cos Notify Channel Admin Ack module is defined.

Implementation of its interfaces, which extend the StructuredProxy and SequenceProxy interfaces by adding a single "acknowledge" operation, is subject to an optional conformance point:.

```

//File: CosNotifyChannelAdminAck.idl
//Part of the extended Notification Service

```

```
#ifndef _COS_NOTIFY_CHANNEL_ADMIN_ACK_IDL_
#define _COS_NOTIFY_CHANNEL_ADMIN_ACK_IDL_
#include <CosNotifyChannelAdmin.idl>
#pragma prefix "omg.org"

module CosNotifyChannelAdminAck {

typedef sequence<long> SequenceNumbers;

interface StructuredProxyPushSupplierAck :
    CosNotifyChannelAdmin::StructuredProxyPushSupplier {
void acknowledge(in SequenceNumbers sequence_numbers);
};

interface StructuredProxyPullSupplierAck :
    CosNotifyChannelAdmin::StructuredProxyPullSupplier {
void acknowledge(in SequenceNumbers sequence_numbers);
};

interface SequenceProxyPushSupplierAck :
    CosNotifyChannelAdmin::SequenceProxyPushSupplier {
void acknowledge(in SequenceNumbers sequence_numbers);
};

interface SequenceProxyPullSupplierAck :
    CosNotifyChannelAdmin::SequenceProxyPullSupplier {
void acknowledge(in SequenceNumbers sequence_numbers);
};
};
#endif
```

### 4.2.3 Overview of Event Acknowledgement

#### 4.2.3.1 Event Acknowledgment on Push Model

Figure 4-1 shows an overview of reliable event delivery with Event Acknowledgment using the push model.

1. Push-style supplier (or proxy supplier) adds SequenceNumber header field to an event.
2. Supplier sends the event to push-style consumer (or proxy consumer) invoking push operation.
3. Consumer checks duplication of the received event using the SequenceNumber.
4. Consumer stores the event to persistent storage.
5. Consumer invokes acknowledge operation
6. Supplier removes the sent and acknowledged event.

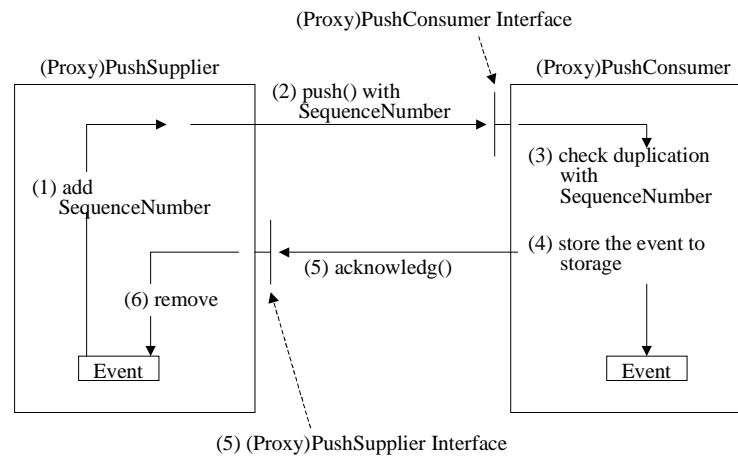

Figure 4-1 Event Acknowledgment on push model

#### 4.2.3.2 Event Acknowledgment on Pull Model

Figure 4-2 shows an overview of the reliable event delivery with Event Acknowledgment using the pull model.

1. Pull-style consumer (or proxy consumer) invokes pull operation of pull-style supplier (or proxy supplier).
2. Supplier adds SequenceNumber header field to an event.
3. Supplier sends the event to consumer as return value of invoked pull operation.
4. Consumer checks duplication of the received event using the SequenceNumber and stores it to persistent storage.
5. Consumer invokes acknowledge operation.
6. Supplier removes the sent and acknowledged event.

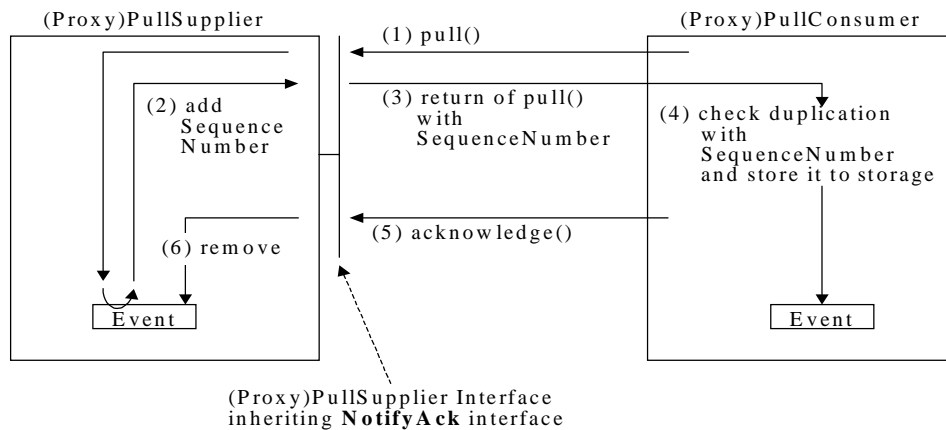

Figure 4-2 Event Acknowledgment on pull model

#### 4.2.4 Scope of Event Acknowledgment

Event Acknowledgment supports delivery of Structured Events and delivery of event batches (sequence of Structured Events) for both the push model and the pull model.

Note: The notification channel mechanisms for translation of Typed events and untyped events (i.e., syntax Any) from a proxy consumer to a proxy supplier, can be used to convert such notifications to structured event syntax. Thus, it is sufficient to specify event acknowledgment extensions only for Structured events and sequence of structured events.

Event Acknowledgment can be applied to any logical connection between a supplier (or proxy supplier) and a consumer (or proxy consumer), even if the supplier or the consumer is a Bridge for interworking with other messaging systems (see Figure 4-3).

Applying Event Acknowledgment to all the logical connections at same time on an event domain can realize end-to-end reliability between supplier and consumer. Each Event Acknowledgment on a logical connection is managed independently. Figure 4-3 shows an example of Reliable Delivery Sequence with end-to-end reliability on an event domain using the push model. Since the Reliable Delivery Sequence on the logical connection 1 is managed independently from the next logical connection 2, when "(1) push" operation is invoked, the event channel A may invoke "(2) acknowledge" operation soon thereafter. The event channel A is not required to invoke "(3) push" operation or wait for "(4) acknowledge" operation on the next logical connection before invocation of "(2) acknowledge".

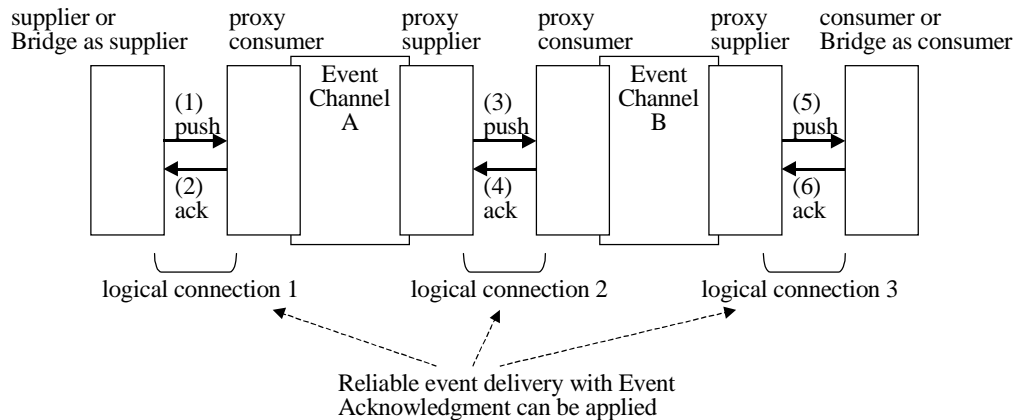

Figure 4-3 Event Acknowledgment on event domain in push model

**Note** – When the Event Acknowledgment is used on a logical connection in an event domain, the supplier (not proxy supplier) can create and add SequenceNumber header field (see Section 4.2.5, "Sequence Number Header Field") to events for improvement of performance. Because insertion of SequenceNumber header field by proxy supplier would require a lot of overhead.

### 4.2.5 Sequence Number Header Field

The following definition is added to the modules CosNotifyCommAck and CosNotifyChannelAdminAck for SequenceNumber header field:

```
const string SequenceNumber = "SequenceNumber";

// SequenceNumber takes a value of type long.
```

The SequenceNumber header field is an event identifier defined as a standard optional header field. The type of its associated value is long. When the Event Acknowledgment is applied to event delivery, the supplier (or proxy supplier) adds the header field to the variable header in the Structured Event before sending the event to the consumer (or proxy consumer). In the case of delivery of an event batch, the supplier adds the header field to only the first Structured Event in the sequence of Structured Events. If the SequenceNumber header field was already added for previous event delivery, the event channel overrides the SequenceNumber header field with a new value.

The SequenceNumber is an integer value which takes a value in the range 0..231-1. It is created and managed per each logical connection between supplier and consumer. In the first event or event batch within the logical connection, SequenceNumber takes the value 0. It is incremented (ex. 0, 1, 2, ..) for each event (in the case of delivery of Structured Event) or for each event batch (in the case of delivery of sequence of Structured Events) sent by the supplier within the logical connection. The next value of 231-1 in the increment is 0.

**Note** – The associated value of the SequenceNumber header field takes a positive value or 0. However long type is applied to the value rather than unsigned long for natural mapping with Java. It is a design policy of the Notification Service specification.

#### 4.2.5.1 Lifetime and Scope of Sequence Number

The lifetime of SequenceNumber is the same as the applied logical connection. When a logical connection is created by invocation of connect operations, a series of SequenceNumber values starts from value 0 for the logical connection. Only when the logical connection is disconnected explicitly by invocation of disconnect operations, is the series of SequenceNumber values for the connection terminated. If a logical connection is created between the same supplier and consumer again, the SequenceNumber is reset and starts from value 0. Otherwise the SequenceNumber is never lost or reset.

The scope of a series of SequenceNumber values is a logical connection between a supplier (or proxy supplier) and a consumer (or proxy consumer). Figure 4-4 shows an example of SequenceNumber management. Since the SequenceNumber is generated and managed per each logical connection, the logical connection 1 and logical connection 2 applies each connection specific SequenceNumber to same events independently.

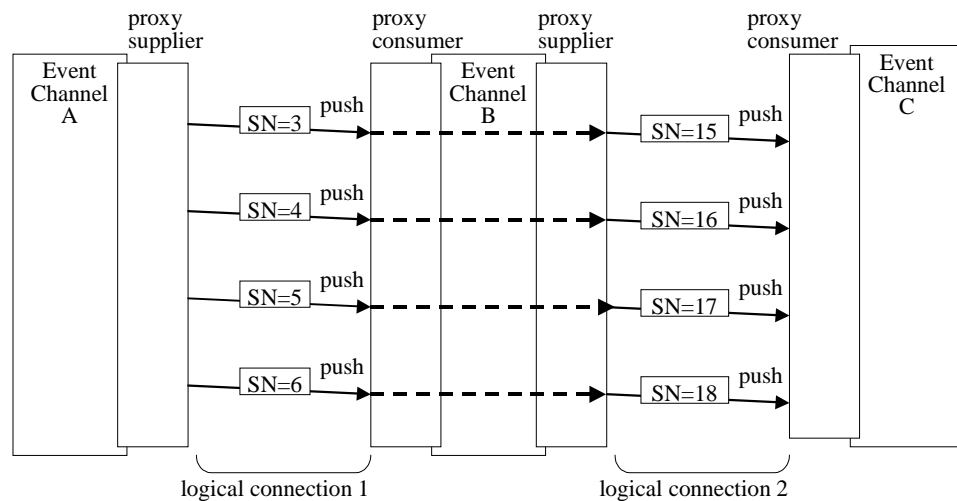

Figure 4-4 Scope of Sequence Number in cascade channel connection

Figure 4-4 shows another example of SequenceNumber management. Even if two or more logical connections are connected to a single Event Channel, each logical connection has its specific series of SequenceNumber values.

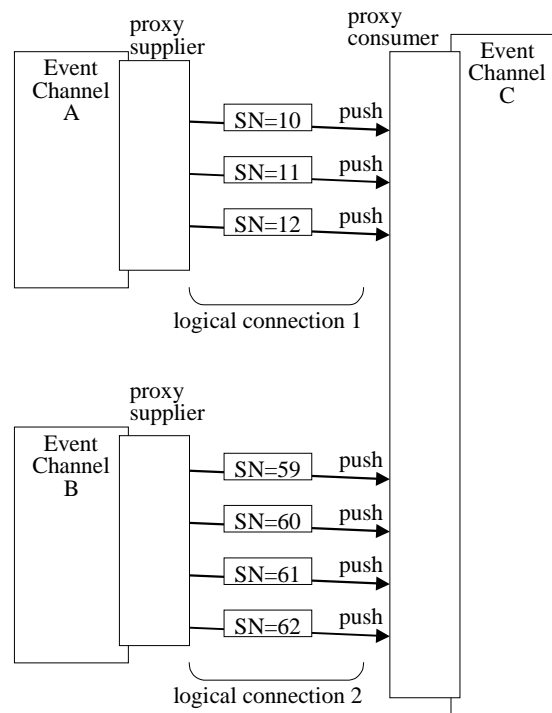

Figure 4-5 Scope of Sequence Number in parallel channel connection

#### 4.2.5.2 Sequence Number Usages

In the push model, Sequence Number is used for duplication check of events on consumer. After a supplier sends an event to a consumer using push operation, if system failure or a communication error occurs before the invocation of the acknowledge operation, the supplier can't know whether the sent event reached the consumer and was processed (ex. stored to persistent storage). In this case, the supplier invokes push operation again to re-send the same event. Thus, when a consumer receives an event from a supplier, the consumer must always execute duplication checking for the event using the Sequence Number, since it might be re-sending the same event.

---

**Note** – In the Notification/JMS interworking, the end of invocation of the push operation does always not mean that the sent even reached the consumer and was processed completely. Because in the case of JMS CLIENT\_ACKNOWLEDGE mode, it must be notified by JMS application with an acknowledgment explicitly. Thus the end of the push operation can't be used instead of acknowledge operation.

---

In the pull model, Sequence Number is used to indicate what events reached a consumer successfully. To reduce the number of acknowledge operation invocations, a consumer may convey multiple SequenceNumber values of received events to the supplier at once by one invocation of acknowledge operation, after some invocations of pull operations.

In the pull model, even if a consumer invokes acknowledge operation once per pull operation invocation, Sequence Number is needed. After a consumer obtains an event using pull operation and sends the Sequence Number of the obtained event using acknowledge operation, if a system failure or a communication error occurs before the end of the invocation of the acknowledge operation, the consumer can't know whether the sent Sequence Number reached the supplier. In this case, the consumer invokes acknowledge operation again to re-send the same Sequence Number. Thus when acknowledge operation is invoked, the supplier must always check the value of Sequence Number before removal of the next event in persistent storage, since it might be a re-send of the same Sequence Number.

#### *4.2.6 Acknowledge operation behavior*

This specification defines additional interfaces, (defined in the two modules specified in this section), each of which has an acknowledge operation to be invoked by the message consumer on these extended supplier interfaces..

The acknowledge operation is added to interfaces derived, in turn, from the interfaces StructuredPushSupplier, StructuredPullSupplier, SequencePushSupplier, SequencePullSupplier and their proxy interfaces in a set of derived interfaces defined in this section (their names add the suffix "Ack" to the interface they are derived from).

The acknowledge operation in each of these interfaces causes the supplier (or proxy supplier) to acknowledge that the consumer (or proxy consumer) received the events which the supplier sent previously. When the operation is invoked, the supplier may remove sent events indicated by the SequenceNumbers input parameter, which specifies values of the SequenceNumber header field in the received events by the consumer.

A Consumer does not always need to invoke the acknowledge operation after each invocation of push or pull operation. A Consumer may convey multiple SequenceNumber values of received events to the supplier at once by one invocation of acknowledge operation after some invocations of push or pull operations.

---

**Note** – This function is provided for mapping to JMS Message Acknowledgment (see "OMG Notification / JMS Interworking " section 2.6.1, "Mapping between Event Acknowledgment and JMS Message Acknowledgment").

---

#### *4.2.7 Reliable Delivery Sequence*

To realize reliable event delivery with Event Acknowledgment, the Notification Service supplier (or proxy supplier) and consumer (or proxy consumer) must support the Reliable Delivery Sequence, which detects a lost event (or event batch) at system failure or communication error and recovers it.

##### *4.2.7.1 Reliable Delivery Sequence for Push Model*

The Reliable Delivery Sequence using the push model consists of the following steps:



1. The supplier sends events to the consumer by invocations of the push operation of the consumer.
2. The supplier detects possibility, in the invocations of push operation, that the events were lost at system failure or communication error using exceptions or timeout of acknowledgment. The timeout means that the supplier's acknowledge operation is not invoked after the invocations of push operation for a time which is specified by QoS parameter `RetryInterval`. If the supplier does not detect the possibility of lost events, it jumps to step (4).
3. The supplier retries the invocations in the step (1) to re-send the events to supplier. When the invocations have failed again due to system failure or communication error, the supplier repeats the same invocations until succeeds in the invocations or the total number of retries specified by QoS parameter `Retries` is satisfied. The interval between original invocations and first retry, or between retries is specified by QoS parameter `RetryInterval`.
4. The consumer checks the received events in duplication using `SequenceNumber` header field. If it is not received events previously, the consumer stores them in persistent storage. If they are received events previously, the consumer ignores the events.
5. The consumer invokes acknowledge operation of the supplier to notify the supplier of successful of the event delivery. The event channel removes the events specified by the `SequenceNumbers` parameter of the acknowledge operation from persistent storage. Even if the consumer detects possibility in the invocations of acknowledge operation that the acknowledgment was lost at system failure or communication error using exceptions, the consumer does not need to retry the acknowledge operation in this step. Because if the acknowledgment was lost, the supplier retries the push operation (see step (2)). As the result, the consumer will execute this step again. The retry count is managed per each logical connection. When invocation of acknowledge operation is successful, or the logical connection is disconnected explicitly by invocation of disconnect operations, the retry count is reset to 0.

#### 4.2.7.2 *Reliable Delivery Sequence for Pull Model*

The Reliable Delivery Sequence using the pull model consists of the following steps:

1. The consumer receives events from the supplier by invocations of the pull operation of the supplier.
2. The consumer detects possibility, in the invocations of the pull operation, that the events were lost at system failure or communication error using exceptions. If the supplier does not detect the possibility of lost events, it jumps to step (4).
3. The consumer retries the invocations in the step (1) to re-receive the events from the supplier.

When the invocations have failed again due to system failure or communication error, the consumer repeats the same invocations until succeeds in the invocations or the total number of retries specified by QoS parameter Retries is satisfied. The interval between original invocations and first retry, or between retries is specified by QoS parameter RetryInterval.

4. The consumer stores the received events in persistent storage.
5. The consumer invokes acknowledge operation of the supplier to notify the supplier of successful of the event delivery. The event supplier removes the events specified by the SequenceNumbers parameter of the acknowledge operation from persistent storage.

A consumer does not always need to invoke the acknowledge operation after each invocation of pull operation. A consumer may convey multiple SequenceNumber values of received events to the supplier at once by one invocation of acknowledge operation after some invocations of pull.

6. If the consumer detects possibility in the invocations of acknowledge operation that the acknowledgment was lost at system failure or communication error using exceptions, the consumer retries the invocation.

When the invocation has failed again due to system failure or communication error, the consumer repeats the same invocation until succeeds in the invocation or the total number of retries specified by QoS parameter Retries is satisfied. The count of retries for acknowledge operation is individual from the count of retry for pull operation in step (3). The interval between original invocation and first retry, or between retries is specified by the QoS parameter RetryInterval.

The retry count is managed per each logical connection. When invocation of acknowledge operation is finished successfully or the logical connection is disconnected explicitly by invocation of disconnect operations, the retry count is reset to 0.

#### *4.2.7.3 Recovery in Failure of Retries*

When the supplier (or proxy supplier) or the consumer (or proxy consumer) fails in all the retries, the supplier or the consumer stops the event delivery on the logical connection, and reports the unrecoverable failure to system administrators.

How to report and recover the failure is out of scope of the specification. The following recovery schemes are shown for example:

The system administrators resolve the failure by hand and then:

1. Reset the retry count and restart the event delivery on the logical connection, or
2. Invoke disconnect operation for the logical connection and then invoke connect operation to restart the event delivery (the SequenceNumber and retry count are reset by the disconnect operation).

In the first scheme, non duplication semantics are preserved between before the failure and after it. But in the second scheme, the semantics might be lost between before the failure and after it.

## 4.2.8 QoS Properties for Reliable Event Delivery

The Event Acknowledgment uses three additional QoS properties, DeliveryReliability, Retries and RetryInterval.

### 4.2.8.1 DeliveryReliability

The Notification Service has no way to specify what mechanism is used for reliable event delivery. The specification defines additional QoS property DeliveryReliability to provide this way. Following definition is added to CosNotifyCommAck module to define this QoS property.

```
const string DeliveryReliability = "DeliveryReliability"
const short None = 0;
const short Acknowledgment = 1;
```

The QoS property specifies a mechanism used by a given supplier (or proxy supplier) and consumer (or proxy consumer) to realize reliable event delivery. Constant values to represent the following setting are defined:

- None - Any reliable delivery mechanism is not applied to event delivery
- Acknowledgment - The Event Acknowledgment described in the specification is applied to event delivery

Table 4-1 shows possible combinations of related QoS properties when the DeliveryReliability property is set to Acknowledgment.

Table 4-1 Combination of related properties for Event Acknowledgment

	Event Reliability	Connection Reliability	Delivery Reliability	Description
combination 1	BestEffort	BestEffort	Acknowledgment	Implementations may support these combinations. But they can't realize complete reliability.
combination 2	BestEffort	Persistent	Acknowledgment	
combination 3	Persistent	BestEffort	----	This combination has no meaning and need not be supported (according to the Notification Service specification).
combination 4	Persistent	Persistent	Acknowledgment	Implementations must support this combination for complete reliability.

### 4.2.8.2 Retries

The following definition is added to CosNotifyCommAck module for Retries QoS property:

```
const string Retries = "Retries"
// Retries takes on a value of type long
```

The QoS property Retries specifies minimum number of retries in the Reliable Delivery Sequence. The type of associated value is long.

#### 4.2.8.3 *RetryInterval*

The following definition is added to **CosNotifyCommAck** module for **RetryInterval** QoS property:

```
const string RetryInterval = "RetryInterval"
// RetryInterval takes on a value of TimeBase::TimeT
```

The QoS property **RetryInterval** specifies interval between original invocation and first retry or between retries. The type of associated value is **TimeBase::TimeT**.

#### 4.2.8.4 *Supported level of the QoS Properties*

Supported level of the QoS property is described in following table.

Table 4-2 Levels at which setting the QoS properties for Reliable Event Delivery is supported

Property	Per-Message	Per-Proxy	Per-Admin	Per-Channel
DeliveryReliability		X	X	X
Retries		X	X	X
RetryInterval		X	X	X

The admin level setting overrides the channel level setting, and proxy level setting overrides the admin level or channel level setting. Note that their properties have no meaning if set on a per-message basis.

### 4.3 *Notification Service QoS and Admin Property Extensions*

To support transactions New QoS and AdminProperties are required. The Notification Service QoS and Admin frameworks are flexible enough to add new QoS and AdminProperty values without changing the Notification Service interfaces. A new QoS and AdminProperties should be seen as an extension rather than a modification of the Notification Service Interfaces. These new QoS and AdminProperties are:

- EnableTransaction QoS is a boolean that enables the notification service client to activate or deactivate the support of the transaction at Notification Service object levels. When this QoS is enabled and applied on the ProxyPushSupplier, ProxyPullConsumer, StructuredProxyPushSupplier, StructuredProxyPullConsumer and TypedProxyPushSupplier, TypedProxyPullConsumer7 levels it will allow the later to behave as a transaction client. When this QoS is disabled and applied on those various types of proxy their transactional client behavior is disabled. This is their default behavior. When the EnableTransaction QoS is enabled at the

ProxyPushConsumer, ProxyPullSupplier, StructuredProxyPushConsumer, StructuredProxyPullSupplier TypedProxyPushConsumer , and TypedProxyPullSupplier7, the proxies' implementations will set their TransactionPolicy to Require\_shared. By default this QoS is disabled, meaning that for the ProxyPushConsumer various types and the ProxyPullSupplier various types the proxies' POAs TransactionPolicy attributes are set to Allows\_none.

If this QoS is applied at the SupplierAdmin, ConsumerAdmin, TypedSupplierAdmin7 or TypedConsumerAdmin7 levels each of their proxy child will enable individually this QoS at their level according to their types. If this QoS is applied at the channel, respectively TypedChannel7 level all the SupplierAdmin and the ConsumerAdmin, respectively, all the TypedSupplierAdmin and the TypedConsumerAdmin objects will enable this QoS, subsequently all the proxy objects apply it individually.

Whenever the EnableTransaction QoS is enabled the EventReliability and the ConnectionReliability QoSs will be setup automatically by the Notification Service to "Persistent". Likewise, when this QoS is disabled the EventReliability and the ConnectionReliability are set to "BestEffort".

- TransactionEvents AdminProperty defines the number of separate events sent in the scope of a transaction. The scope of this property is the ProxyPushSupplier, ProxyPullConsumer, StructuredProxyPushSupplier, StructuredProxyPullConsumer, TypedProxyPushSupplier, and TypedProxyPullSupplier.
- TransactionEventSequences AdminProperty defines the number of event sequences sent in the scope of a transaction. The scope of this property is the SequenceProxyPushSupplier and SequenceProxyPullConsumer.
- TransactionTimeout adminProperty defines the timeout period in number of seconds associated with routing transaction created. If the parameter has a non-zero value n, then the created routing transaction will be subject to being rolled back if they do not complete before n seconds after their creation. If its value is zero, then no application specified time-out is established. This adminProperty is aimed to be mapped on the unsigned long input parameter of the OTS Current.set\_timeout() operation. This adminProperty is applied on all the proxies that behave as transaction clients.

When those adminProperties are applied at the SupplierAdmin, ConsumerAdmin, or EventChannel level they will affect only the proxies with transaction client behavior. Table 4-3 summarizes the scope of the new QoS and AdminProperties at the proxy level. It also summarizes proxies' transactional roles. Empty Cells denotes that QoS is not applicable.

Table 4-3 New Notification Service QoS and AdminProperties scope

	Proxy Types	QoS	AdminProperties		
		Enable Transaction	Transaction Timeout	Transaction EventSequences	Transaction Events
TransactionClientRole	ProxyPushSupplier,	X	X		X
	ProxyPullConsumer,	X	X		X
	StructuredProxyPushSupplier	X	X		X
	StructuredProxyPullConsumer	X	X		X
	SequenceProxyPushSupplier	X	X	X	
	SequenceProxyPullConsumer	X	X	X	
	TypedProxyPushSupplier7,	X	X		X
	TypedProxyPullConsumer7	X	X		X
Transaction Server Role	ProxyPushConsumer	X			
	ProxyPullSupplier	X			
	StructuredProxyPushConsumer	X			
	StructuredProxyPullSupplier	X			
	SequenceProxyPushConsumer	X			
	SequenceProxyPullSupplier	X			
	TypedProxyPushConsumer7	X			
	TypedProxyPullSupplier7	X			