UML™ Profile and Interchange Models for Enterprise Application Integration (EAI) Specification

This OMG document replaces the submission (ad/2001-09-17) and the draft adopted specification (ptc/2002-01-21). It is an OMG Final Adopted Specification, which has been approved by the OMG board and technical plenaries, and is currently in the finalization phase. Comments on the content of this document are welcomed, and should be directed to *issues@omg.org* by July 1, 2002.

You may view the pending issues for this specification from the OMG revision issues web page <http://www.omg.org/issues/>; however, at the time of this writing there were no pending issues.

The FTF Recommendation and Report for this specification will be published on September 20, 2002.

UML™ Profile and Interchange Models for Enterprise Application Integration (EAI) Specification

**Final Adopted Specification
February 2002**

Copyright 2001 DSTC
Copyright 2001 Hitachi, Ltd.
Copyright 2001 IBM Corporation
Copyright 2001 Oracle Corporation
Copyright 2001 Rational Corporation
Copyright 2001 Unisys Corporation

The companies listed above have granted to the Object Management Group, Inc. (OMG) a nonexclusive, royalty-free, paid up, worldwide license to copy and distribute this document and to modify this document and distribute copies of the modified version. Each of the copyright holders listed above has agreed that no person shall be deemed to have infringed the copyright in the included material of any such copyright holder by reason of having used the specification set forth herein or having conformed any computer software to the specification.

PATENT

The attention of adopters is directed to the possibility that compliance with or adoption of OMG specifications may require use of an invention covered by patent rights. OMG shall not be responsible for identifying patents for which a license may be required by any OMG specification, or for conducting legal inquiries into the legal validity or scope of those patents that are brought to its attention. OMG specifications are prospective and advisory only. Prospective users are responsible for protecting themselves against liability for infringement of patents.

NOTICE

The information contained in this document is subject to change without notice. The material in this document details an Object Management Group specification in accordance with the license and notices set forth on this page. This document does not represent a commitment to implement any portion of this specification in any company's products.

WHILE THE INFORMATION IN THIS PUBLICATION IS BELIEVED TO BE ACCURATE, THE OBJECT MANAGEMENT GROUP AND THE COMPANIES LISTED ABOVE MAKE NO WARRANTY OF ANY KIND, EXPRESS OR IMPLIED, WITH REGARD TO THIS MATERIAL INCLUDING, BUT NOT LIMITED TO ANY WARRANTY OF TITLE OR OWNERSHIP, IMPLIED WARRANTY OF MERCHANTABILITY OR WARRANTY OF FITNESS FOR PARTICULAR PURPOSE OR USE. In no event shall The Object Management Group or any of the companies listed above be liable for errors contained herein or for indirect, incidental, special, consequential, reliance or cover damages, including loss of profits, revenue, data or use, incurred by any user or any third party. The copyright holders listed above acknowledge that the Object Management Group (acting itself or through its designees) is and shall at all times be the sole entity that may authorize developers, suppliers and sellers of computer software to use certification marks, trademarks or other special designations to indicate compliance with these materials. This document contains information which is protected by copyright. All Rights Reserved. No part of this work covered by copyright herein may be reproduced or used in any form or by any means--graphic, electronic, or mechanical, including photocopying, recording, taping, or information storage and retrieval systems--without permission of the copyright owner.

RESTRICTED RIGHTS LEGEND. Use, duplication, or disclosure by government is subject to restrictions as set forth in subdivision (c) (1) (ii) of the Right in Technical Data and Computer Software Clause at DFARS 252.227.7013 OMG[®] and Object Management are registered trademarks of the Object Management Group, Inc. OMG OBJECT MANAGEMENT GROUP, CORBA, CORBA ACADEMY, CORBA ACADEMY & DESIGN, THE INFORMATION BROKERAGE, OBJECT REQUEST BROKER, OMG IDL, CORBA FACILITIES, CORBA SERVICES, CORBANET, CORBAMED, CORBA DOMAINS, GIOP, IIOP, OMA, CORBA THE GEEK, UNIFIED MODELING LANGUAGE, UML, and UML CUBE LOGO are registered trademarks or trademarks of the Object Management Group, Inc.

X/Open is a trademark of X/Open Company Ltd.

ISSUE REPORTING

All OMG specifications are subject to continuous review and improvement. As part of this process we encourage readers to report any ambiguities, inconsistencies, or inaccuracies they may find by completing the Issue Reporting Form listed on the main web page <http://www.omg.org>, under Documents & Specifications, Report a Bug/Issue.

Contents

List of Figures	vii
Preface	xv
Part 1 - Introduction	
1. Introduction and Guide	1-1
1.1 Introduction	1-1
1.2 Attachments	1-2
2. Scope	2-1
2.1 Scenario 1: Connectivity	2-1
2.2 Scenario 2: Information Sharing	2-2
2.3 Scenario 3: Process Collaboration	2-3
3. Modeling Approach	3-1
3.1 Metamodel	3-1
3.2 UML Profile	3-2
3.3 Four-layered Architecture	3-2
3.4 Semantics	3-2
4. Compliance	4-1
4.1 Overview	4-1
4.2 Compliance with the UML Collaboration Profile	4-1
4.2.1 General Compliance	4-1
4.2.2 Visualization	4-2
4.3 Compliance with the UML Activity Profile	4-2

4.3.1	General Compliance	4-2
4.3.2	Visualization	4-2
4.4	Compliance with the MOF-based EAI Metamodel	4-3
4.5	Compliance Statement Examples	4-3
5.	Requirements and Areas for Discussion	5-1
5.1	Mandatory Requirements	5-1
5.1.1	Event-Based Architecture	5-1
5.1.2	Heterogeneous Environment	5-2
5.1.3	XML	5-2
5.1.4	XMI	5-3
5.1.5	UML Profile for EDOC	5-3
5.1.6	MOF alignment	5-4
5.1.7	Proof of Concept of Profile	5-4
5.1.8	Demonstration that Models are Implementable	5-4
5.2	Discussion issues	5-5
5.2.1	Development and Management Aid	5-5
5.2.2	Tool Support	5-5
5.3	Relationship to Envisioned OMG Technology	5-5
5.3.1	Real-time	5-5
5.4	Relationship to Existing Standards	5-6
5.4.1	UML	5-6
5.4.2	Meta Object Facility (MOF)	5-6
5.4.3	Common Warehouse Metamodel (CWM)	5-6
5.5	Other Related Activities	5-7

Part 2 - Metamodel

6.	EAI Integration Metamodel	6-1
6.1	EAI Integration Specializes FCM	6-1
6.2	FCM Derived Associations	6-2
6.2.1	Motivation	6-2
6.2.2	FCM Diagrams	6-2
6.2.3	Composite Nodes	6-4
6.2.4	Composite Nodes and Their Contents	6-4
6.2.5	Relationship between the Interface of a Composite Node and its Contents	6-5
6.3	EAI Specializations of the FCM	6-6
6.3.1	Motivation	6-6
6.3.2	EAILink	6-6
6.3.3	EAITerminal	6-7

6.3.4	EAMessageContent	6-7
6.3.5	EAMessageOperation	6-10
6.3.6	EASource and EASink.	6-11
6.3.7	EAIQueue.	6-11
6.3.8	EAIQueuedInputTerminal and EAIQueuedOutput Terminal	6-12
6.3.9	EAIQueuedSource and EAIQueuedSink	6-13
6.3.10	Operators	6-14
6.3.11	Adapters	6-17
6.4	Kinds of Operator.	6-21
6.4.1	Operators	6-21
6.4.2	Topic-based publish/subscribe	6-34
6.5	CCA Component Library for EAI	6-36
6.5.1	Operators	6-36
6.5.2	Adapters	6-41
6.5.3	CCA and EAI Metamodel Mapping Tables	6-44
7. EAI Common Application Metamodel		7-1
7.1	Business Requirements and Value	7-1
7.2	Common Application Metamodel for Applications Interfaces	7-2
7.2.1	End-to-End Connector Usage Using EAI Common Application Metamodel	7-3
7.3	Common Application Metamodel	7-4
7.3.1	Enterprise Application Interface Metamodels	7-5
7.3.2	Language Metamodels	7-5
7.3.3	Physical Representation Model: Type Descriptor Metamodel	7-6
7.3.4	Type Descriptor Metamodel Descriptions	7-9
7.3.5	Type Descriptor Formulas	7-11
7.3.6	Type Descriptor Formula Examples	7-12
7.3.7	Physical Representation Model: TDLang Metamodel	7-19
7.3.8	TDLang Metamodel Descriptions.	7-20
7.3.9	Physical Representation Model: Convergent Metamodel	7-22
7.3.10	Convergent Metamodel Descriptions	7-23
7.3.11	Sample Serialization of Convergent Metamodel	7-23

Part 3 - Profile Definition

8. Collaboration Modeling		8-1
8.1	Overview	8-1

Contents

8.1.1	General Approach.	8-1
8.1.2	Use of UML operations	8-2
8.1.3	Concrete Notation.	8-2
8.1.4	Chapter structure	8-2
8.2	Terminals	8-2
8.3	Operators	8-4
8.3.1	Primitive Operator	8-4
8.3.2	Transformers and Database Transformers	8-4
8.3.3	Filters	8-5
8.3.4	Streams	8-6
8.3.5	Post Daters	8-7
8.3.6	Source Adapters	8-8
8.3.7	Target Adapters.	8-9
8.3.8	Call Adapters	8-10
8.3.9	Request/Reply Adapters	8-11
8.3.10	Sources and Queued Sources	8-12
8.3.11	Sinks and Queued Sinks	8-13
8.3.12	Aggregators	8-13
8.3.13	Timers.	8-14
8.3.14	Routers	8-16
8.3.15	Subscription Operators.	8-17
8.3.16	Publication Operators.	8-17
8.3.17	Topic Publishers	8-19
8.3.18	Compound Operators	8-19
8.4	Resources	8-27
8.5	Message Formats	8-27
8.5.1	MessageContent Core.	8-27
8.5.2	Basic MOM Message Structure	8-30
8.6	Mapping with Metamodel	8-32
8.6.1	Terminals	8-33
8.6.2	Operators	8-33
8.6.3	Resources	8-38
8.6.4	Message Formats	8-39
9.	Activity Modeling	9-1
9.1	Modeling Integration Processes	9-1
9.2	An Integration Process Scenario	9-1
9.2.1	The Exchange Process	9-2
9.2.2	Modeling message flow explicitly	9-3
9.2.3	Modeling control flow	9-5

9.2.4	Abstracting detail by decomposition	9-6
9.2.5	Further fragmentary examples	9-6
9.3	Profile Element Summary	9-9
9.3.1	Stereotypes	9-9
9.3.2	Tagged Values.	9-11
9.3.3	Mapping to EAI Metamodel.	9-12

Part 4- Proof of Concept

10.	Example: Connectivity and Information Sharing.	10-1
10.1	The Brokerage Business.	10-1
10.2	Connection of Enterprises to the Online Brokerage System	10-2
10.3	The On-line Brokerage System	10-6
10.4	International Brokerage Server.	10-10
10.4.1	Orders	10-10
10.4.2	Notifications.	10-10
10.5	Investment Manager Server	10-13
10.5.1	Orders	10-13
10.5.2	Notifications.	10-13
10.6	Middleware Server and Back-End Brokerage System	10-14
10.7	Publication	10-15
11.	Example Using the EDOC CCA.	11-1
11.1	Example	11-1

Part 5- Implementation Mappings

12.	Mapping to WebSphere MQ Integrator	12-1
12.1	WebSphere MQ Messaging	12-1
12.1.1	WebSphere MQ Messages	12-2
12.1.2	WebSphere MQ Message Queuing	12-3
12.2	WebSphere MQ Integrator Message Flows	12-4
12.2.1	Summary	12-4
12.2.2	WMQIMessageFlow.	12-4
12.2.3	WMQICompoundNode	12-5
12.2.4	WMQIPrimitiveNode	12-6
12.2.5	Supplied WMQIPrimitiveNodes.	12-6
12.2.6	The Role of the WMQI message-broker topology	12-8
13.	Java Message Service (JMS).	13-1
13.1	PTP Domain.	13-1

Contents

13.2	Pub/Sub Domain	13-4
14.	Language Metamodels	14-1
14.1	COBOL Metamodel	14-1
14.1.1	COBOL Metamodel Descriptions	14-4
14.2	PL/I Metamodel	14-7
14.2.1	PL/I Metamodel Descriptions	14-9
14.3	C Metamodel	14-14
14.3.1	C Metamodel Descriptions	14-17
14.4	C++ Metamodel	14-19
14.4.1	C++ Metamodel Descriptions	14-20
	Appendix A - Non-normative Enterprise Application Interface Metamodels	A-1

List of Figures

FCMComponent metamodel diagram (from ad/2001-06-09)	6-2
Flow Composition Model main diagram (from ad/2001-06-09)	6-3
Flow Composition Model datatypes	6-3
Derived association between FCMCommand and FCMComposition	6-4
Derived association between a composite node, its content nodes and its composed connections	6-5
Derived association between FCMTerminal and FCMPParameter	6-5
Definition of EAILink	6-6
EAITerminal	6-7
EAI MessageContent	6-8
EAIHeader	6-9
EAIExceptionNotice	6-9
XML message elements	6-10
MessageOperation	6-10
Sources and sinks	6-11
EAIQueue	6-12
EAIQueuedOutputTerminal and EAIQueuedInputTerminal	6-12
QueuedSource and QueuedTarget	6-13
Definitions of PrimitiveOperator and CompoundOperator	6-14
EAIMessageFlow	6-16
Derived association between a terminal inside a composite node and the corresponding terminal outside.....	6-17
SourceAdapter.....	6-17
EAITargetAdapter	6-18
EAI CallAdapter	6-19
EAIRequestFormat	6-20
EAIRequestReplyAdapter	6-21
Filter	6-22
Stream	6-23

Figures

EAIPostDater	6-24
Transformer	6-24
EAIIDBTransformer	6-25
EAIAggregator	6-26
EAIRouter	6-27
EAIRouter and EAIRouterUpdate	6-27
EAIRouterUpdateFormat	6-28
SubscriptionOperator	6-29
EAISubscriptionFormat	6-29
EAISubscription	6-30
SubscriptionFilter	6-30
EAISubscriptionRule, EAITopicRule and EAIContentRule	6-31
EAIPublicationOperator and EAISubscriptionOperator	6-31
Example SubscriptionTable instance diagram	6-32
TimeSetOperator	6-32
EAIMessageTimerCondition	6-33
EAIExpiryFormat	6-33
EAITimeCheckOperator	6-34
Topics allowed by an EAITopicRule	6-35
Relationship between a terminal and the topics for which it has a subscription	6-35
Relationship between publishers, subscribers and topics	6-36
CCA notation for a sample generic EAIPrimitiveOperator	6-37
CCA notation for sample EAITransformer	6-38
CCA notation for a sample EAIFilter	6-39
CCA notation for a sample EAISStream	6-40
CCA notation for sample EAICompoundOperator	6-41
CCA notation for a sample EAISourceAdapter	6-41
CCA notation for a sample Pull mode EAISourceAdapter	6-42
CCA notation for a sample EAITargetAdapter	6-42
CCA notation for sample EAICallAdapter	6-44
Multiple Application and Development Environments	7-1
Application Interface Metamodel	7-3
Type Descriptor metamodel	7-7
TDLang to Type Descriptor	7-8
Type Descriptor Stereotypes	7-8
TDLang Metamodel	7-20
Convergent Metamodel	7-22
Class diagram for prototypical primitive operator with terminals	8-3
Class diagram for prototypical transformer	8-4
Class diagram for prototypical database transformormer	8-5
Class diagram for prototypical filter	8-6

Class diagram for prototypical stream	8-7
Class diagram for prototypical post dater	8-7
Class diagram for prototypical source adapter	8-8
Class diagram for prototypical target adapter	8-9
Class diagram for prototypical call adapter	8-10
Class diagram from prototypical request/reply adapter	8-11
Class diagram for prototypical source	8-12
Class diagram for prototypical queued source	8-12
Class diagram for prototypical sink	8-13
Class diagram for prototypical aggregator	8-14
Class diagram for prototypical timer	8-15
Class diagram for prototypical router	8-16
Class diagram for prototypical subscription operator	8-17
Class diagram for prototypical publication operator	8-18
Class diagram for prototypical topic publisher	8-19
Class diagram for example compound operator	8-20
Class diagram for a compound operator with compound components	8-20
Terminals for example of compound operator	8-21
Collaboration diagram for example compound operator	8-22
Synchronous and asynchronous links	8-23
Class diagram for example with components of same type	8-23
Collaboration diagram for example with components of same type	8-24
Configuration of call and request/reply adapters	8-25
Configuration of publication and subscription operators	8-26
A simple message content class	8-29
A model of a message containing a table	8-29
Example of the use of the ExceptionNotice and MOMHeader stereotypes	8-31
Example of the use of the MOMHeader stereotype	8-32
Basic way of modeling message based integration with Activities (Exchange example)	9-3
Application of the "messageFlow" stereotype to emphasize data-flow aspects	9-4
Application integration example with "messageflow" stereotype (partial)	9-4
Optional control flow transitions between activities within a single system	9-5
Decomposition of the integration step "Place Quote" in the context of the Exchange example ...	9-6
Modeling multiple inputs and outputs with join and fork pseudo-states	9-7
Modeling internal data flow with object flow states	9-7
Example of a decision node to model rule-based routing	9-8
Synchronization with forks and joins	9-8
Dynamic concurrent invocation of an activity	9-8
Explicit modeling of an event for an adapter implementation	9-9
As-is architecture for international and investment managers	10-2
Brokerage company - component connections	10-3

Figures

Brokerage company - components	10-4
International brokerage systems - terminals	10-5
Investment-manager systems - terminals	10-5
On-line brokerage system - terminals	10-6
On-line brokerage system - components	10-7
On-line brokerage - component connections	10-7
International brokerage server - terminals	10-8
Investment-manager server - terminals	10-9
Middleware server - terminals	10-9
Back-end brokerage system - terminals	10-9
Pub/sub server - terminals	10-10
IBS - components	10-11
IBS - component connections	10-12
Back-end brokerage system - components	10-14
Back-end brokerage system - component connections	10-15
Back-end processing system - terminals	10-15
Pub/sub server - components	10-16
Pub/sub server - component connections	10-16
BrokerageCompany component connections	11-2
Ordering Components	11-3
OnlineBrokerage Component	11-3
2000IMSystemOrdering Protocol	11-4
1999IMSystemOrdering Protocol	11-4
JapanOrdering Protocol	11-5
StandardInternationalOrdering Protocol	11-5
Detail of OnlineBrokerage Component	11-6
Detail of InvestmentManagerServer Component	11-6
Detail of 2000IMIBSHandler Component	11-7
Detail of 1990IMIBSHandler Component	11-8
Detail of InternationaBrokerageServer Component	11-9
Detail of JapanIMIBSHandler Component	11-10
Detail of StandardInternationalIMIBSHandler Component	11-11
WMQRemoteQueue and WMQAliasQueue	12-3
Summary of the main usage of operator stereotypes	12-4
WMQIMessageFlow	12-5
Compound and primitive nodes in WMQI	12-6
WMQIntegrator class diagram	12-9
JMS QueueSender	13-2
JMS QueueReceiver	13-3
JMS QueueBrowser	13-3

A JMSSubscriberListener expects incoming messages	13-4
Model for the content of the JMS subscription table	13-4
JMSTopicSubscriberCreator	13-5
JMSSubscriptionInfrastructure	13-5
A JMS TopicPublisher	13-5
JMSPublicationInfrastructure	13-6
COBOL Metamodel	14-2
TDLang to COBOL	14-3
COBOL Stereotypes	14-3
PL/I Metamodel	14-8
TDLang to PL/I	14-9
PL/I Stereotypes	14-9
C Metamodel	14-14
TDLang to C	14-15
C Derivation	14-15
C Names	14-16
C Datatype - Model Types	14-16
C User Types	14-17
CPP Metamodel	14-20
CPP Model Types	14-20
IMS Transaction Message Metamodel	A-2
IMS Transaction Message Prefix	A-3
OTMA Prefix - Defined Types	A-3
OTMA Prefix - State Data Defined Types	A-3
OTMA Prefix - Security Data Defined Types	A-4
IMS Messages Primitive Types	A-4
MFS Inheritance View	A-17
MFS Relationship View	A-18
MFS Attribute View	A-19
CICS BMS Relationship View	A-40
CICS BMS Inheritance View	A-40
CICS BMS Attributes	A-41

Figures

Preface

About the Object Management Group

The Object Management Group, Inc. (OMG) is an international organization supported by over 600 members, including information system vendors, software developers and users. Founded in 1989, the OMG promotes the theory and practice of object-oriented technology in software development. The organization's charter includes the establishment of industry guidelines and object management specifications to provide a common framework for application development. Primary goals are the reusability, portability, and interoperability of object-based software in distributed, heterogeneous environments. Conformance to these specifications will make it possible to develop a heterogeneous applications environment across all major hardware platforms and operating systems.

OMG's objectives are to foster the growth of object technology and influence its direction by establishing the Object Management Architecture (OMA). The OMA provides the conceptual infrastructure upon which all OMG specifications are based.

What is CORBA?

The Common Object Request Broker Architecture (CORBA), is the Object Management Group's answer to the need for interoperability among the rapidly proliferating number of hardware and software products available today. Simply stated, CORBA allows applications to communicate with one another no matter where they are located or who has designed them. CORBA 1.1 was introduced in 1991 by Object Management Group (OMG) and defined the Interface Definition Language (IDL) and the Application Programming Interfaces (API) that enable client/server object interaction within a specific implementation of an Object Request Broker (ORB). CORBA 2.0, adopted in December of 1994, defines true interoperability by specifying how ORBs from different vendors can interoperate.

OMG Documents

The OMG documentation is organized as follows.

OMG Modeling

- ***Unified Modeling Language (UML) Specification*** defines a graphical language for visualizing, specifying, constructing, and documenting the artifacts of distributed object systems.
- ***Meta-Object Facility (MOF) Specification*** defines a set of CORBA IDL interfaces that can be used to define and manipulate a set of interoperable metamodels and their corresponding models.
- ***OMG XML Metadata Interchange (XMI) Specification*** supports the interchange of any kind of metadata that can be expressed using the MOF specification, including both model and metamodel information.
- ***Common Warehouse Metamodel (CWM) Specification*** mainly consists of definitions of metamodels in the following domains:
 - Object model (a subset of UML)
 - CWM foundation
 - Relational data resources
 - Record data resources
 - Multidimensional data resources
 - XML data resources
 - Data transformations
 - OLAP (On-line Analytical Processing)
 - Data mining
 - Information visualization
 - Business nomenclature
 - Warehouse process
 - Warehouse operation

Object Management Architecture Guide

This document defines the OMG's technical objectives and terminology and describes the conceptual models upon which OMG standards are based. It defines the umbrella architecture for the OMG standards. It also provides information about the policies and procedures of OMG, such as how standards are proposed, evaluated, and accepted.

CORBA: Common Object Request Broker Architecture and Specification

Contains the architecture and specifications for the Object Request Broker.

OMG Interface Definition Language (IDL) Mapping Specifications

These documents provide a standardized way to define the interfaces to CORBA objects. The IDL definition is the contract between the implementor of an object and the client. IDL is a strongly typed declarative language that is programming language-independent. Language mappings enable objects to be implemented and sent requests in the developer's programming language of choice in a style that is natural to that language. The OMG has an expanding set of language mappings, including Ada, C, C++, COBOL, IDL to Java, Java to IDL, Lisp, and Smalltalk.

CORBA services

Object Services are general purpose services that are either fundamental for developing useful CORBA-based applications composed of distributed objects, or that provide a universal-application domain-independent basis for application interoperability.

These services are the basic building blocks for distributed object applications. Compliant objects can be combined in many different ways and put to many different uses in applications. They can be used to construct higher level facilities and object frameworks that can interoperate across multiple platform environments.

Adopted OMG Object Services are collectively called CORBA services and include specifications such as *Collection*, *Concurrency*, *Event*, *Externalization*, *Naming*, *Licensing*, *Life Cycle*, *Notification*, *Persistent Object*, *Property*, *Query*, *Relationship*, *Security*, *Time*, *Trader*, and *Transaction*.

CORBA facilities

Common Facilities are interfaces for horizontal end-user-oriented facilities applicable to most domains. Adopted OMG Common Facilities are collectively called CORBA facilities and include specifications such as *Internationalization and Time*, and *Mobile Agent Facility*.

Object Frameworks and Domain Interfaces

Unlike the interfaces to individual parts of the OMA "plumbing" infrastructure, Object Frameworks are complete higher level components that provide functionality of direct interest to end-users in particular application or technology domains.

Domain Task Forces concentrate on Object Framework specifications that include Domain Interfaces for application domains such as Finance, Healthcare, Manufacturing, Telecoms, E-Commerce, and Transportation.

Currently, specifications are available in the following domains:

- *CORBA Business*: Comprised of specifications that relate to the OMG-compliant interfaces for business systems.

-
- *CORBA Finance*: Targets a vitally important vertical market: financial services and accounting. These important application areas are present in virtually all organizations: including all forms of monetary transactions, payroll, billing, and so forth.
 - *CORBA Healthcare*: Comprised of specifications that relate to the healthcare industry and represents vendors, healthcare providers, payers, and end users.
 - *CORBA Life Science*: Comprised of specifications that relate to the OMG-compliant interfaces for the life science industry.
 - *CORBA Manufacturing*: Contains specifications that relate to the manufacturing industry. This group of specifications defines standardized object-oriented interfaces between related services and functions.
 - *CORBA Telecoms*: Comprised of specifications that relate to the OMG-compliant interfaces for telecommunication systems.
 - *CORBA Transportation*: Comprised of specifications that relate to the OMG-compliant interfaces for transportation systems.

Obtaining OMG Documents

The OMG collects information for each book in the documentation set by issuing Requests for Information, Requests for Proposals, and Requests for Comment and, with its membership, evaluating the responses. Specifications are adopted as standards only when representatives of the OMG membership accept them as such by vote. (The policies and procedures of the OMG are described in detail in the *Object Management Architecture Guide*.)

OMG formal documents are available from our web site in PostScript and PDF format. To obtain print-on-demand books in the documentation set or other OMG publications, contact the Object Management Group, Inc. at:

OMG Headquarters
250 First Avenue
Needham, MA 02494
USA
Tel: +1-781-444-0404
Fax: +1-781-444-0320
pubs@omg.org
<http://www.omg.org>

Structure of this Document

Part I - Introduction

Chapter 1 includes the introductory information, scope, modeling approach and compliance requirements.

Part 2 - Metamodel

Comprised of Chapter 2 (EAI Integration Metamodel and Chapter 3 (EAI Common Application Metamodel).

Part 3 - Profile Definition

The profile presented here focuses on two main modeling approaches, based on collaborations and based on activities. These are described in Chapters 4 and 5, respectively.

The collaboration-modeling approach is based on a modeling framework of classes that provide detailed definitions of the semantics of the collaboration. It is thus useful for providing the detailed specification of message flows in the design of integration subsystems.

The activity-modeling approach is based on the use of activity graphs. This approach is particularly useful for showing the overall control and data flow required for integration, typically at a higher level than in collaboration modeling.

Casting the metamodel as a UML profile allows EAI architecture models to be notated using standard UML notation. This means that most UML tools (specifically ones which support the extension mechanisms of UML, such as stereotypes and tagged values) can be used to define EAI architecture models.

Standard practice for defining UML profiles has been adopted. A mapping of metamodel classes to their base UML classes, with accompanying stereotypes, tagged values and constraints is summarized for each approach. An implementation of this mapping can be used, for example, to generate metadata conforming to the EAI metamodel from XMI generated from models notated using the UML profile. Specialized EAI tools will more likely use the metamodel than the UML profile as a basis for storing and manipulating models.

The art of defining a UML profile is to provide the best fit possible with UML, so that the notation is natural for a modeler in the relevant domain (EAI in this case), and fits with one's general intuitions about the the meaning of the elements of UML that are used in the profile. The profile described here has been designed with these principles in mind.

Part 4- Proof of Concept

This section provides a proof of concept for the profile by giving examples of the use of the profile for actual EAI modeling. An example is provided that is relevant to both of the scenarios of the Scope that are covered by this specification and uses collaboration modeling. In Chapter 7, a variant of part of this example is presented in the CCA of the UML Profile for EDOC.

Part 5 - Implementation Mappings

The profile presented in this specification is intended to provide the basis for modeling EAI architectures, largely at a logical level. However, the implementation of such an architecture requires, of course, the use of various technologies and tools appropriate to integration, such as message brokers. This section presents a selection of mappings of the modeling approaches of the profile into such implementation technologies. The set of technologies discussed here is by no means an exhaustive set of those applicable to EAI, but is simply intended to demonstrate how the profile is usable with such technologies.

Typographical Conventions

The type styles shown below are used in this document to distinguish programming statements from ordinary English. However, these conventions are not used in tables or section headings where no distinction is necessary.

Helvetica bold - OMG Interface Definition Language (OMG IDL) and syntax elements.

Courier bold - Programming language elements.

Helvetica - Exceptions

Terms that appear in *italics* are defined in the glossary. Italic text also represents the name of a document, specification, or other publication.

Acknowledgments

The following companies submitted and/or supported parts of this specification:

- CBOP
- Charles Schwab & Co.
- Data Access Technologies
- DSTC
- Hitachi, Ltd.
- International Business Machines Corporation
- IONA
- Oracle Corporation
- Rational Software Corporation
- Unisys Corporation

Part 1 - Introduction

Contents

This section contains the following chapters.

Chapter	Page
1. Introduction and Guide	1-1
2. Scope	2-1
3. Modeling Approach	3-1
4. Compliance	4-1
5. Requirements and Areas for Discussion	5-1

1.1 Introduction

As enterprises adapt to business change and new opportunities, they seek to build on their existing strengths and assets for competitive advantage. Electronic trading with consumers and other businesses is one of these trends. This frequently entails building new applications by coupling existing ones, which is known as Enterprise Application Integration (EAI). This is most often done with some form of messaging that provides loose coupling to make it easy to change, to link heterogeneous systems and operating environments, and to maximize resilience and robustness in cases of partial failure.

Enterprise Application Integration technology is being promoted to integrate legacy systems with new packages. But integrating legacy applications with new software is a difficult and expensive task due, in large part, to the necessity of customizing each connection that ties together two disparate applications. There is no single mechanism to describe how one application may allow itself to be invoked by another.

We intend to solve this problem by defining and publishing a metadata interchange standard for information about accessing application interfaces. The goal is to simplify application integration by standardizing application metadata for invoking and translating application information. Once these standards exist, tools may be constructed to facilitate the development, execution, and management of these integration points.

Such connected systems are inherently complex to define and manage. A well-known approach to managing complexity is to define levels of concern. Modeling with UML has been shown to be successful at representing differing levels of detail. The appropriate level for EAI is *application architecture* — the treatment of the interfaces and interactions between applications. UML has been used successfully for modeling at this level, and this specification presents the authors' view of best practice for using the existing UML for modeling application architectures, i.e., architectures composed by enterprises to enable application integration.

1.2 Attachments

XMI and DTD files for the EAI Metamodels can be found in OMG document number ad/2001-08-25.

The scope is described with three generic scenarios representing the evolution of the integration requirements:

- Scenario 1. Application integration through connectivity.
- Scenario 2. Application integration through information sharing.
- Scenario 3. Application integration through process collaboration.

For each scenario major characteristics and requirements are described. Obviously, scenario 2 requires the functionality described in scenario 1 and scenario 3 requires the functionality described in scenario 2. However, as we move forward from scenario 1 to scenario 2 and scenario 3, the underlying functionality becomes less visible and more and more hidden in the infrastructure.

As the industry moves forward, scenario 3-or an updated version of scenario 3-will most likely become the dominant scenario.

2.1 Scenario 1: Connectivity

A small set of applications has to communicate synchronously or asynchronously with each other to provide business functions.

It must be possible to model the following abstractions:

- Service requester and provider
- Synchronous and asynchronous service request
- Request, reply and notification

In this scenario, the participating applications share a common architecture. They share the data model of the communication and they are able to activate the appropriate applications to obtain a service.

There is a need for additional abstractions such as queues (local or remote) and topics. At one level, queues and topics should be invisible, but at a lower level of detail they may well be required.

2.2 Scenario 2: Information Sharing

This scenario comes from handling securities.

An investor orders a stock trade, typically by sending a message describing the stock trade to be carried out. (We discuss the creation of the message in the next scenario.) This stock trade order triggers a set of autonomous actions: checking the investor's account, checking the position of the institution, notifying a broker if the trade is large, and notifying a broker as well as the investor if there are any issues.

If the order is accepted the market place is selected and an institution such as a market maker executes the trade. After execution, the investor records are updated. Information about the executed trade is sent to the investor via pager and e-mail and to internal systems such as bookkeeping that require the information.

The securities firm is not only interested in handling requests properly but also in answering questions from investors, regulators and other interested parties, both internal and external, at any stage during or after a trade.

A key requirement is that it should be easy to add new participants and new functionality with no or minimal impact to existing participants and services.

A good way to deal with this scenario is to model it as information sharing between applications and actors, such as investors and brokers. Such information sharing can be implemented through publishing and subscribing to business events enabling communication between the participants. We assume that all applications reflect a shared understanding about the meaning and sequence of the individual business events and act according to this shared understanding. However, we will assume that applications and actors participating in these processes are isolated from knowledge about who will consume their information and in which topic and format the recipients expect it.

It must be possible to model the following abstractions:

- Messages representing business events. (We are much less interested in messages that do not represent business events.)
- Publication of messages and business events-the ability to share information.
- Queues and topics-it must be possible to separate output containers of sending applications from input containers of receiving applications.
- Data transformation-each program must be able to create or consume messages in its own format. Applications should be able to use data structures suitable to their own language, e.g., a C++ program should not have to handle SWIFT or XML formats. Data transformation has to include data verification.
- Propagation-the ability to use any protocol to receive or deliver a message, including the allocation of a received message to a queue.

- Subscriptions to determine the receiving programs, their input containers or propagation routes, and their transformations. Subscriptions should be able to represent various cases, including interest of users, data routing, activation of programs.
- Retention to keep the history of relevant messages from creation through stages of processing, transformation, and consumption.
- Auditing, tracking, and mining-the ability to find and relate messages, both consumed and in flight.

In this scenario, the applications share a common business event and process model at the conceptual level. However, details of the layout of the data may vary, e.g., one program may use SWIFT structures, while another uses XML.

The term information sharing is used to characterize the interaction between participants providing information for the right recipients. Where time is of the essence and information is communicated with messaging/event technology we refer to zero latency information sharing.

2.3 Scenario 3: Process Collaboration

Company A offers its merchandise through the Internet. While some customers order goods using a browser interface, the majority of the orders are communicated business-to-business (B2B) using one of the B2B protocols. In simplified form, a B2B protocol consists of the following business events:

- RFQ (Request For Quotation)
- Offer
- Acceptance
- Shipment notice
- Bill
- Payment

Other events involved in negotiations, inquiries, changes, cancellation, and other additional steps (e.g., steps involving communications problems) are not considered in this simplification.

Company A communicates with business partners over secure Internet channels. Non repudiation, high reliability (including disaster tolerance), exactly once semantics, fully automated user-accessible application-independent auditing and tracking are basic requirements. Outgoing communication will use the requested protocol. Messages representing business events are carefully checked for process, sequence and data accuracy. Any error will raise an exception condition. Incoming communication is checked carefully as well. Some errors may need manual correction, which needs careful documentation.

Company A offers the flexibility for customers to use their favorite B2B protocols as long as they can represent a proper order process.

Applications should be independent of the specifics of the business protocols, but it is assumed that the desired interaction with an application can be achieved using its interfaces. At least three levels of interface support can be distinguished in applications:

- Applications that are only able to react through activation of their interfaces.
- Applications that can accept requests and can notify the outside world using events. At least some of these applications have to be configured to activate the desired events.
- Applications that additionally provide a process interface. These applications have to be configured to use the desired process structure.

In any of these cases it can not be assumed that the process as seen by the application is the process as seen by the selected B2B protocol. Actually it is desirable to hide the internal processes from business partners, so they can be changed without impact to the outside world and potential competitive advantages can be hidden. To achieve this, a mediation service has to be available to transform the process and data semantics embedded in the B2B protocols to the process and data semantics of an enterprise's internal processes. This transformation will be called semantic mediation. Semantic mediation is part of the core functionality required for the integration of autonomous applications.

Flexibility in B2B communication requires a repository of information that governs communication with a particular trading partners. This information includes security (including application security), notifications, subscriptions, B2B protocols and their extensions and adaptations, and indications for internal routing. It should be possible to group trading partners according to various criteria. This information comprises what is often termed a trading community agreement.

To model this level of integration it must be possible to model the following abstractions in addition to the abstractions defined in the previous scenarios:

- Semantic mediation-the ability to transform process and data structures between applications and B2B protocols.
- Propagation between enterprises-secure, with non repudiation, exactly once semantics, and disaster protection.
- B2B-level auditing, tracking, and mining-a business event can be reviewed, analyzed in its process context, and mined for insight into business behavior.
- B2B protocols-processes based on the communication of business events or business events in the context of process and customer relations.
- Trading community agreements in a repository containing information about trading partner and the communications with them.

This specification addresses primarily the first two scenarios. It provides enablement for scenario 3, but this scenario requires other elements that go beyond its scope. Scenario 3 is included here to clarify the relationship to work going on in ebXML and elsewhere.

The EAI specification is delivered as a complete MOF-based metamodel and a UML profile. This approach facilitates exchange with both UML tools and MOF-based tools/repositories.

3.1 Metamodel

As is the common practice, the MOF-based metamodel is captured as an object-oriented model expressed using a suitably restricted subset of the UML notation. The UML elements used in this specification are:

- Classes with attributes and (query) operations.
- Binary associations, where composite and navigation adornments are permitted. Association classes and qualified associations are not permitted.
- Packages, including nesting and imports.
- The object constraint language, OCL, for expressing well-formedness constraints.

The EAI metamodel is documented using the following conventions:

- The overall structure of the metamodel is shown as one or more package diagrams, depending on the level of nesting required.
- Packages are limited in size so that only one class diagram per package is required.
- In explaining a package, the important collaborations between classes are identified and described as one. Individual classes are described separately where this enhances the overall understanding of the model.
- Well-formedness constraints are also grouped with the collaborations to which they are relevant.
- The semantics of each collaboration is described as specified below.

3.2 UML Profile

The UML profile allows modelers to use UML as a concrete notation for producing EAI models using UML modeling tools which support the UML extensions mechanisms, chiefly stereotypes, tagged values and custom icons. Some tools are available, e.g., [ref objecteering], which can accept a profile definition and configure a modeling tool to force modelers to conform to that profile by using only elements of the UML subset and only the stereotypes, tagged values and icons declared in the profile.

A mapping between the metamodel and the UML profile is defined as part of the EAI specification. This is intended as a basis for the development of tools that will transform models expressed using the UML profile into models conforming to the metamodel, and vice versa. The details of the mapping are given as part of the definition of the profile.

3.3 Four-layered Architecture

The relationship of the EAI specification to the four-layered architecture defined by the OMG is as follows. MOF is at level 3, so the EAI metamodel is at level 2. The EAI UML profile is also at this level - it is just a set of additional constraints (what stereotypes, tagged values, etc.) on how UML is to be used when notating EAI models. The EAI metamodel should be thought of as the definition of the abstract syntax of EAI models. An EAI model, which is at level 1, is an expression of this abstract syntax. An EAI model is a specification of the architecture of an event-based system and the allowable information flows through that system. Level 0, then, represents actual behaviors of an event-based system, for example a particular instantiation of the architecture or a particular message flow through that system. These behaviors and instantiations must conform to the specification of behavior captured by the EAI model.

3.4 Semantics

There are a number of approaches to semantics. One is to describe how a model (in this case an EAI model) constrains the set of possible behaviors at M0 which satisfy that model. This can be captured formally by explicitly modeling (in some formal language) the structure of the abstract syntax, the structure of M0 behaviors and the relationship between the two. However, a formal definition can be somewhat inaccessible. The approach taken in this specification is to describe the semantics in English, using a model of M0 behaviors to help clarify the explanation where appropriate.

4.1 Overview

Compliance with this standard by a vendor can be partial. To facilitate this the compliance points have been defined separately (Section 4.2, “Compliance with the UML Collaboration Profile,” on page 4-1, Section 4.3, “Compliance with the UML Activity Profile,” on page 4-2, and Section 4.4, “Compliance with the MOF-based EAI Metamodel,” on page 4-3) and examples of plausible compliance statements are provided (Section 4.5, “Compliance Statement Examples,” on page 4-3).

References to other OMG standards are abbreviated in the compliance point definitions, but in all cases refer to the specific revisions listed in the table below:

Standard	Version Referenced
UML	1.4
XMI	1.2
MOF	1.3

4.2 Compliance with the UML Collaboration Profile

The UML Collaboration Profile is defined in Chapter 8.

4.2.1 General Compliance

A compliant implementation supports the UML XMI exchange mechanism for the UML packages extended by the Collaboration Profile. It also supports the UML exchange mechanism for the stereotypes and tagged values defined by the Profile. Furthermore it checks the well-formedness constraints that the Profile defines.

The UML packages that the Profile extends are "Behavioral Elements::Collaborations" plus the transitive closure of all of the packages upon which that package depends.

An implementation that satisfies the General Compliance point can be described as one that "complies with the UML Collaboration Profile for EAI."

4.2.2 Visualization

A compliant implementation supports the UML notation for the packages extended by the Collaboration Profile and for the EAI extensions to those packages. An implementation that complies with the Collaboration Profile may or may not satisfy the Visualization compliance point.

An implementation that complies with the Collaboration Profile and that satisfies the Visualization compliance point for the Profile can be described as one that "complies with the UML Collaboration Profile for EAI including UML notation."

4.3 Compliance with the UML Activity Profile

The UML Activity Profile is defined in the Activity Modeling chapter.

4.3.1 General Compliance

A compliant implementation supports the UML XMI exchange mechanism for the UML packages extended by the Activity Profile. It also supports the UML XMI exchange mechanism for the stereotypes and tagged values defined by the Profile. Furthermore it checks the well-formedness constraints that the Profile defines.

The UML packages that the Profile extends are "Behavioral Elements::Activity Graphs" plus the transitive closure of all of the packages upon which that package depends.

An implementation that satisfies the General Compliance point can be described as one that "complies with the UML Activity Profile for EAI."

4.3.2 Visualization

A compliant implementation supports the UML notation for the packages extended by the Activity Profile and for the EAI extensions to those packages. An implementation that complies with Activity Profile may or may not satisfy the Visualization compliance point.

An implementation that complies with the Activity Profile and that satisfies the Visualization compliance point for the Profile can be described as one that "complies with the UML Activity Profile for EAI including UML notation."

4.4 Compliance with the MOF-based EAI Metamodel

There is a separate and independent compliance point for each of the MOF metamodels defined in this specification.

A compliant implementation of a metamodel supports exchange based on the XMI DTD generated from the metamodel. It also checks the well-formedness constraints defined by the metamodel.

The metamodels defined by the specification and the corresponding generated XMI DTDs are as follows:

EAI MOF based metamodel	Chapter in which the metamodel is defined	XMI DTD
Integration	6	CM4EAI
COBOL	14	COBOLtdlang
PL/I	14	pliTDLang
C	14	tdlang
C++	14	cpptdlang

The language metamodels depend on the TDLang and typedescriptorTDLang XMI DTDs.

There are no specific requirements for visualization of the EAI Metamodel.

A compliant implementation of the Integration metamodel can be described as one that "complies with the EAI Integration metamodel;" a compliant implementation of the COBOL metamodel can be described as one that "complies with the EAI COBOL metamodel;" etc.

4.5 Compliance Statement Examples

Any combination of the compliance points can be used. Examples of compliance statements follow:

- Tool XXX complies with the UML Collaboration Profile for EAI.
- Tool XXX complies with the UML Collaboration Profile for EAI including UML notation.
- Tool XXX complies with the UML Activity Profile for EAI.
- Tool XXX complies with the UML Activity Profile for EAI including UML notation.
- Tool XXX complies with the UML Collaboration and Activity Profiles.
- Tool XXX complies with the UML Activity Profile including UML notation and with the UML Collaboration Profile.

- Tool XXX complies with the UML Collaboration Profile including notation and with the UML Activity Profile including notation.
- Tool XXX complies with the UML Collaboration and Activity Profiles, including UML notation for both. (Note: this statement is equivalent to the previous one.)
- Tool XXX complies with the EAI C Metamodel.
- Tool XXX complies with the EAI C++ Metamodel .
- Tool XXX complies with the EAI Integration, C, C++, and PL/1 metamodels.
- Tool XXX complies with the UML Collaboration and Activity Profiles including notation for both. It also complies with the EAI Integration, COBOL, and PL/1 metamodels.

Requirements and Areas for Discussion

5.1 Mandatory Requirements

The RFP requirements are quoted in italics, followed by a summary of the specification's response.

Responses shall propose a UML profile suitable for modeling at the architectural level, as distinct from business modeling or application system design. The purpose is to represent IT systems (existing systems, vendor-supplied packages and newly developed application systems) at the level appropriate for integration between them.

This UML profile is suitable for modeling at the architectural level because it is based on a metamodel that supports composition and decomposition, and it defines interfaces to systems, applications and packages, both new and existing.

5.1.1 Event-Based Architecture

Proposals shall provide the means for specifying architectures and processes based on the flow of business events. They shall provide for:

- Integration of applications based on the occurrence of events.
- Description of a process or information flow as a series of business events.
- Architectural decomposition of the defined processes or information flows into their implementing applications, each the sender or receiver of events.

The principal means used for showing event-based flows is in UML collaboration diagrams (*Collaboration Modeling* chapter 8). An alternative representation using activity graphs is given (*Activity Modeling* chapter 9). The modeling elements defined are well known in the industry as popular means for constructing event-based flows. The Integration metamodel (*EAI Integration Metamodel* chapter 6) inherits the composition mechanism of the Flow Composition Model (FCM) in the UML Profile for EDOC, which models senders and receivers as sources and sinks.

5.1.1.1 *Modeling Elements*

They shall provide for loose coupling including, but not necessarily restricted to, the use of messaging and message brokers. At least the following elements shall be included:

- Publish and Subscribe - distribution of messages based on dynamically varying subscriptions
- Routing, fanout and filtering of messages - distribution based on rules or attributes
- Validation and transformation (mapping) of messages
- Augmentation (enrichment) and correlation (fan-in) - adding data (e.g., from a database) and accumulating data from related messages
- Deadline and post-dating - checking on-time arrival and avoiding early delivery
- Exception processing

All these elements are defined in the metamodel and mapped into the profile. In addition, the basic semantics of messaging and queueing are defined, as this paradigm is commonly used for loosely coupling systems. The use of message brokers is demonstrated in the non-normative mapping to a commercial product (*Mapping to WebSphere MQ Integrator* chapter).

5.1.2 *Heterogeneous Environment*

Proposals shall be generally applicable to heterogeneous networks of programming systems, operating systems, application systems, servers and packages. They shall show how they apply to mixtures that include ORBs, Internet servers and other subsystems.

The message-based approach adopted in this specification is well known to be applicable across a wide variety of systems and servers. Heterogeneity of programming systems is shown in the non-normative language models (Chapter 14). Interfaces to several subsystems are given in Appendix A. The sample in *Example: Connectivity and Information Sharing* chapter illustrates the use of several servers and protocols (both networking and data interchange protocols) across more than one enterprise.

5.1.3 *XML*

Proposals shall show how they are compatible with the use of XML in message formats for business data.

The model allows messages to be in different formats, including XML. The message metamodel includes a format specification that acknowledges the distinction between self-defining and separately defined message formats (see Section 6.3.4, “EAIMessageContent,” on page 6-7). In the case of XML, generic DTDs or schemas can be defined as a domain, or a message format may comply with a specific DTD in another domain.

5.1.4 XMI

Proposals shall show how they are compatible with the rendering of metadata in XMI. Models shall be interchangeable between different tools through the use of XMI. This shall include the use of XMI to define message formats and the CWM metamodel for transformations.

Because we have not extended the OMG MOF, XMI can be used to interchange EAI models. XMI files for the EAI metamodels are provided as supplementary material to this specification.

The EAI transformation operator neither prescribes nor proscribes the way in which transformations can be defined. Rather, the metamodel and profile furnish the means by which interfaces may be modeled. The architect or designer can simply name the salient attributes of messages or define interfaces in greater detail using the EAI Common Application Metamodel (CAM, see Chapter 7). The transformation details are left to the implementation, and this includes the case where a transformation tool is based on XMI and the CWM.

5.1.5 UML Profile for EDOC

Proposals shall show how they are aligned consistently with the UML Profile for EDOC.

The joint specification to the EDOC RFP includes a model for composing flow components (see OMG document ad/01-06-09, UML Profile for Enterprise Distributed Object Computing). This Flow Composition Model (FCM) unifies component composition and coordination both for events and for other styles of communication. This model is at a higher level of abstraction than the message flows, sources, targets, adapters, and operators in EAI. The model is applicable to EAI, and the EAI Integration metamodel (see Chapter 6) is a specialization of it. In particular, we use it to represent:

- Simple and compound flow components
- Input and output data sets
- Data flows, control flows and guard conditions

The EAI Integration metamodel includes publish/subscribe elements, and these are related to the Events Profile in EDOC as follows:

EAI Integration metamodel	EDOC Events Profile metamodel
EAISubscription	Subscription
EAISubscriptionFilter	NotificationRule
EAIMessage (in context of PublicationOperator and SubscriptionOperator)	PubSubNotice

The UML Profile for EDOC defines a Component Collaboration Architecture (CCA), part of the Enterprise Collaboration Architecture (ECA). Section 6.5, “CCA Component Library for EAI,” on page 6-39 presents a mapping between the CCA and the EAI Integration metamodel.

In the EAI CAM (Chapter 7) the links are as follows:

- Both the Java language metamodel and the FCM metamodel in EDOC require CAM to tie parameters into the data typing and type composition structure that the metamodel provides.
- The Java metamodel has associations to the TDLang metamodel. Java typed elements implement the TDLangElement class, while the associated simple and complex Java data types inherit from TDLangClassifier class. Java classes will implement the TDLangComposedType.
- The FCM metamodel contains FCMPParameter class, which associates to TDLangElement class. FCMPParameter represents a data bytestring of the elements. Contents of the bytestring are mapped to the associated element by TDLangElement.

5.1.6 MOF Alignment

Proposals shall conform to the OMG MOF.

No extensions to the OMG MOF are proposed.

5.1.7 Proof of Concept of Profile

Submissions shall provide sample models expressed in terms of the profile.

Part 4 shows sample models that use class diagrams and collaboration diagrams of the profile. These come from from the financial services industry. Chapter 9 shows an example of activity graph usage with the profile. The presentation in behavioral diagrams will be considered non-normative.

5.1.8 Demonstration that Models are Implementable

Submissions shall show that models built using the profile will map to practical implementations using generally available products and services. An acceptable example of such a demonstration for the publish/subscribe elements of the profile would be consistency with one or more of the CORBA Notification Service, JMS or OAMAS. For other elements, an example would be a mapping to a commercially available class of products, e.g., message brokers or mail routers.

A non-normative mapping to an implementation in JMS is given in Chapter 13 - “Java Message Service (JMS)”. This demonstrates not only the publish/subscribe elements but also those that support direct messaging. A non-normative mapping to IBM's WebSphere MQ (formerly MQSeries) and WebSphere MQ Integrator (formerly

MQSeries Integrator) is given in Chapter 12 - “Mapping to WebSphere MQ Integrator”, which is, in fact, a specialization of the metamodel on which the UML Profile for EAI is based.

5.2 *Discussion issues*

5.2.1 *Development and Management Aid*

Submissions should discuss how the submitted profile aids or simplifies the architecture, development and management of EAI systems and solutions.

The profile defines the principal modeling elements needed for an IT architect or designer to take a business-level model or view and create an event-based architecture for EAI. Tools can be built to enable a designer take such a model to the next level of refinement (see below). With suitable instrumentation of run-time infrastructure, middleware and applications, monitoring and reporting of the behavior of executing systems is possible in a way that highlights bottlenecks, inconsistencies and other management problems by relating and comparing to the original or revised models. Such a feedback loop enables continuous process improvement.

5.2.2 *Tool Support*

Submissions should discuss how the submitted profile enables tool support for EAI definition and management and how such tools can be judged more or less compatible with the profile.

Tool compliance is discussed in Chapter 4. By providing a metamodel as the underpinning to the profile, the specification enables UML-based modeling and design tools to be coupled with implementation and configuration tools. A model developed with this profile can be converted to a high-level implementation model. For example, as a result of the mapping from the Integration metamodel to WebSphere MQ Integrator (WMQI) in Chapter 12, a UML tool can be written that exports an architectural model defined with this profile to an outline model in WMQI. A designer could then use the WMQI tool to complete the lower-level and implementation details of the model prior to testing and deployment.

5.3 *Relationship to Envisioned OMG Technology*

This section describes the relationship, in terms of alignment, reuse or overlap with OMG standards for which RFPs have been issued but which have not yet been adopted.

5.3.1 *Real-time*

The UML Profile for Scheduling, Performance and Time (from the Real-time PSIG, OMG document number ad/01-06-14) emphasizes the definition of quality of service (QoS). The UML Profile for EAI makes provision for QoS specifications in the provision of streams (Section 6.4.1.2, “EAISStream,” on page 6-23) and resources

(Section 6.3.7, “EAIQueue,” on page 6-12). These are left non-specific in this specification and can be augmented with specifications from the UML Profile for Scheduling, Performance, and Time.

5.4 *Relationship to Existing Standards*

5.4.1 *UML*

As a UML profile, this specification defines uses of UML 1.4 for the purposes of application integration. This includes classes and stereotypes.

5.4.2 *Meta Object Facility (MOF)*

UML is MOF compliant. This specification defines UML elements and adds additional semantics appropriate to the context of event-based architectures in EAI. Chapter 2 presents a metamodel in which each class is a MOF Class instance at the M2 level.

5.4.3 *Common Warehouse Metamodel (CWM)*

The Common Warehouse Metamodel (CWM) defines and publishes a metadata interchange standard for data warehousing and business intelligence tools and resources, e.g., relational databases, IMS DL/I databases and OLAP systems.

CWM gives metamodels for generic data structures that include XML documents, COBOL records, C structures and SQL schemas. These are aimed at data stores but are generic. They could be applied to message content descriptions. This level of refinement is a natural progression from the architectural designs supported by the UML Profile for Event-based Architectures in EAI.

CWM is highly reusable and is independent of any particular tool or data resource. It reduces the work required to integrate data warehousing and business intelligence tools. DB2 Data Warehouse Center/Warehouse Manager (V7) now supports CWM. DB2 Information Catalog Manager plans to support CWM in V8.

CWM is needed for data transformation in a data warehousing and business intelligence environment. It provides data type mapping between a mix of different data resources, facilitates data translations from one data resource into another, allows data driven impact analysis for data lineage and allows data resource schemas to be viewed by developers.

The EAI Common Application Metamodel (CAM), which is described in Chapter 7, defines and publishes a metadata interchange standard for information about accessing enterprise applications such as CICS and IMS. CAM is reusable and is independent of any particular tool or middleware. It is likely to provide an incentive to connector suppliers by reducing the work required to create and develop connectors and/or connector builder tools.

CAM is needed for data transformation in an enterprise application integration environment. It provides data type mapping between mixed languages and facilitates data translations from one language and platform domain into another, it will allow data driven impact analysis for application productivity and quality assurance, and it will allow programming language data declarations to be viewed by developers.

In CAM a language metamodel, such as the COBOL metamodel, is used by enterprise application programs to define data structures which represent connector interfaces. It is important for connector tools to show a connector developer the source language, the target language and the mapping between the two. The CAM language metamodel also includes the declaration text in the model. This permits the connector/adaptor developer to see the entire COBOL data declaration, including comments and any other documentation that would help him/her understand the business role played by each field in the declaration.

While CWM focus on data resources, CAM is for applications. CWM and CAM complement each other; both are needed in an enterprise IT environment.

5.5 *Other Related Activities*

The RFP states that submissions may deal with business-to-business (B-to-B) models as well as intra-enterprise models. However, there are other significant standards activities in B-to-B, and this specification does not address the area directly. EAI is a valuable underpinning to B-to-B along with other facets such as process modeling, which is addressed to a certain extent in the UML Profile for EDOC Business Processes Profile. To offer public services and interfaces to trading partners, an enterprise has to ensure that it has well-defined interfaces and well-architected systems. Much trading is inherently event based, and so streams, messages, publications, sources, targets, filters, transformations and other operations are natural modeling elements for the intra-enterprise systems that are needed to support both internal and public electronic trading.

B-to-B modeling is dealt with in ebXML, which is based on a particular approach to B-to-B implementation. However, there are other approaches, including web services (SOAP, WSDL, UDDI, the draft web services flow language - WSFL - and XLANG) at W3C and OASIS, RosettaNet, OBI, EDI, OAG BODs and several industry-specific formats and protocols. There continues to be a high volume of activity and a rapid rate of change.

Part 2 - Metamodel

Contents

This section contains the following chapters.

Chapter	Page
6. EAI Integration Metamodel	6-1
7. EAI Common Application Metamodel	7-1

This section describes the EAI metamodel, which, as explained in Chapter 6, is MOF compliant. The metamodel captures the essential EAI concepts. It may also be viewed as the abstract syntax of a language for specifying architectures for enterprise application integration. The metamodel is in two sections:

- The Integration Metamodel dealing with connectivity, composition and behavior
- The Common Application Metamodel dealing with interfaces and formats

Chapter 7 describes a UML profile for the language of the Integration Metamodel. It defines how UML (and therefore UML modeling tools) can be used as a concrete notation for this language.

6.1 EAI Integration Specializes FCM

The EAI Integration metamodel is a specialization of the Flow Composition Model from the UML Profile for EDOC (OMG Document Number: ad/2001-06-09, Part I, Chapter 5, Section 2). The following sections make extensive use of terms described in the FCM, and consequently it is assumed that the reader is familiar with it.

The UML Profile for EDOC also presents the Component Collaboration Architecture (CCA), part of the EDOC Enterprise Collaboration Architecture (ad/2001-06-09, Part I, Chapter 3, Section 2). In Section 6.5, “CCA Component Library for EAI,” on page 6-39 a mapping is presented between EAI Integration metamodel and the CCA. The mapping introduces the concept of a CCA “Component Library.” Many of the concepts in EAI are represented as standard components that may be used in EAI compositions.

The EAI Integration metamodel reuses the concepts of flow, flow node and composition. It adds the following basic concepts which are required in EAI architectural modeling:

- Asynchronous communication
- Message queuing
- Message content and format

It additionally uses the FCM to define as flow components a number of concepts common to the message oriented middleware used in EAI, such a message routing, transformation, and publish/subscribe communication.

6.2 FCM Derived Associations

6.2.1 Motivation

EAI modeling makes extensive use of the compositional aspects of the FCM. Consequently, and in order to simplify the rendering of the EAI metamodel as a UML profile, this section names some derived associations that are computable from (but not manifest in) the FCM. These are:

- Composite/implementingComposition
- CompositeNode/contents
- CompositeNode/ComposedConnections
- Representation/parameter

Note that these derived associations, although specifically part of the EAI metamodel package, do not require additional specializations or constraints beyond those already present in the FCM. Since derived associations can be computed from information already in the metamodel, a tool that manipulates the a model need not save derived associations when saving a model.

6.2.2 FCM Diagrams

The metamodel diagrams from the FCM are included for the reader's reference without further comment. The reader is referred to ad/2001-06-09 for explanatory text.

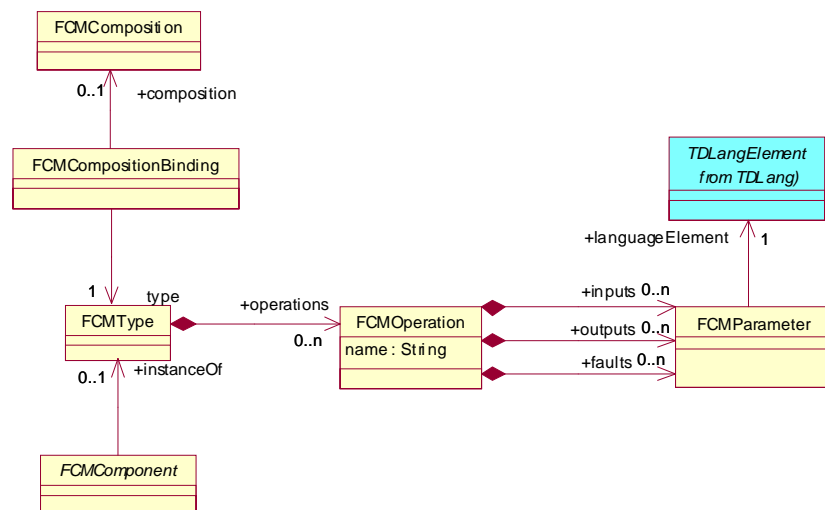

Figure 6-1 FCMComponent metamodel diagram (from ad/2001-06-09)

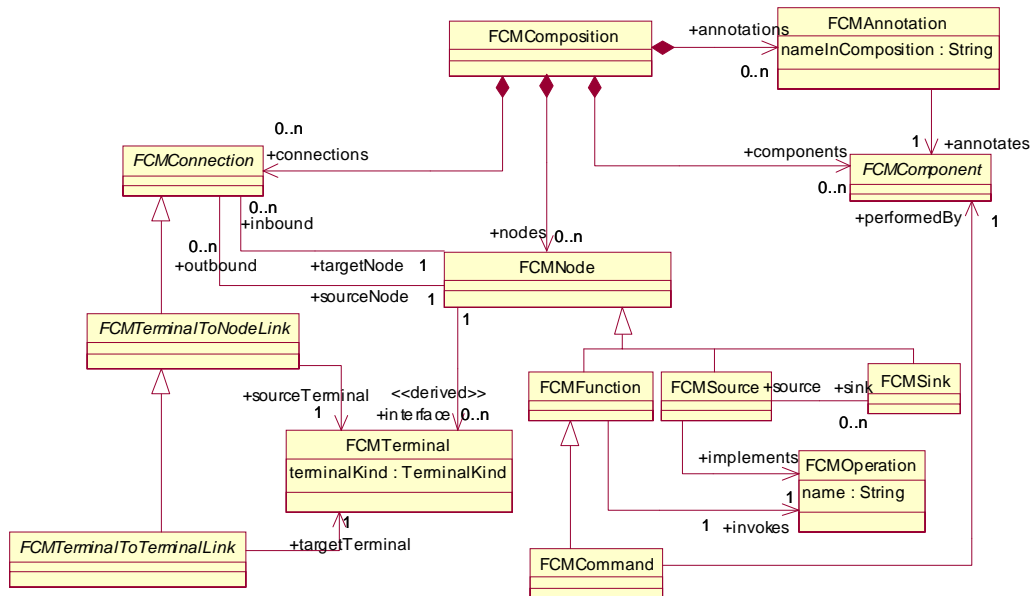

Figure 6-2 Flow Composition Model main diagram (from ad/2001-06-09)

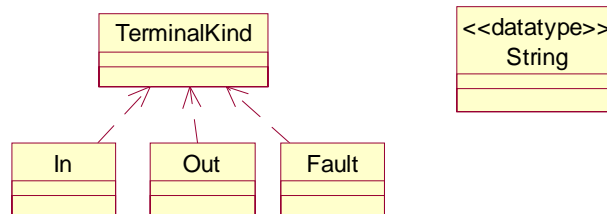

Figure 6-3 Flow Composition Model datatypes

6.2.3 Composite Nodes

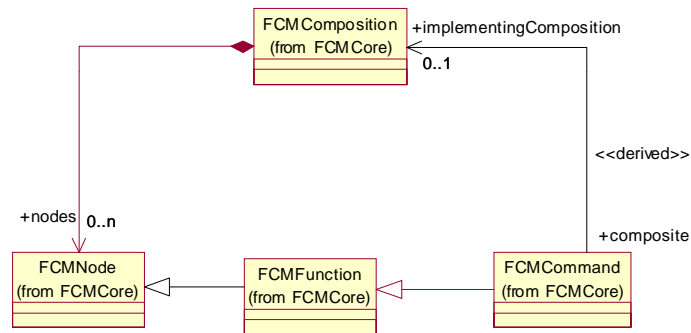

Figure 6-4 Derived association between FCMCommand and FCMComposition

Definition

The composition method in the FCM is to construct an FCMCommand (which is an FCMNode) from an FCMComposition (Figure 6-4). In the derived association, the FCMCommand is a composite node, and the FCMComposition is its implementingComposition. An FCMComposition can be regarded as fully specifying the externals of the composite node constructed from it; the FCMSource and FCMSink nodes contained in the implementingComposition specify the FCMTType and FCMCompositionBinding of the composite FCMCommand.

More than one instance of an FCMCommand can use the same instance of an FCMComposition to define its behavior. Some of the EAI operators are defined via compositions of 'primitive' EAI behaviors. We define them as subclasses of FCMCommand, each with a constraint that they use a particular implementingComposition.

Constraint

An FCMCommand is performedBy an FCMComponent (see Figure 6-2 on page 6-3). An FCMComponent may be linked via its FCMTType and an FCMCompositionBinding to an FCMComposition (see Figure 6-1 on page 6-2).

In the derived association FCMCommand is associated with zero or one implementingComposition.

6.2.4 Composite Nodes and Their Contents

Using the derived association above, we further document the relationship between an FCMCommand (compositeNode) that is implemented as an FCMComposition, and the nodes (contents) and connections (composedConnections) contained in the FCMComposition. We note that there are further derivable relationships (not shown here) between an FCMCommand and the FCMAnotations and FCMComponents that are helped by the FCMComposition.

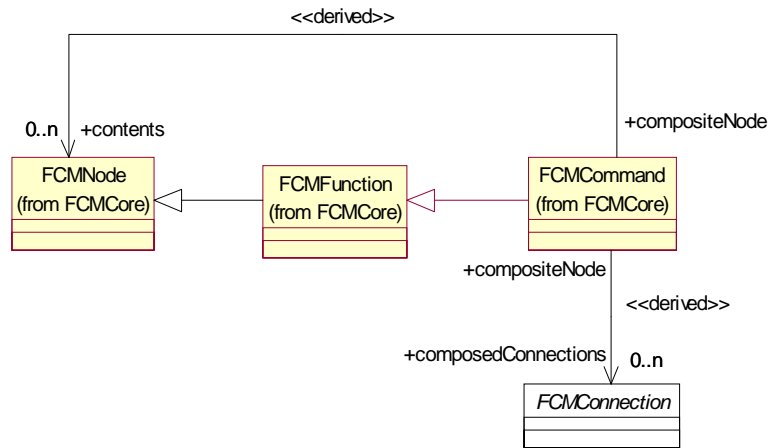

Figure 6-5 Derived association between a composite node, its content nodes and its composed connections

Constraint

`FCMCommand.contents = FCMCommand.implementingComposition.nodes`

`FCMCommand.composedConnections = FCMCommand.implementingComposition.connections`

6.2.5 Relationship between the Interface of a Composite Node and its Contents

An **FCMNode** has **FCMTerminals** as interfaces, but the FCM ties type information to the **FCMParameters** of an **FCMOperation**. We say that an **FCMTerminal** is the representation of an **FCMParameter**.

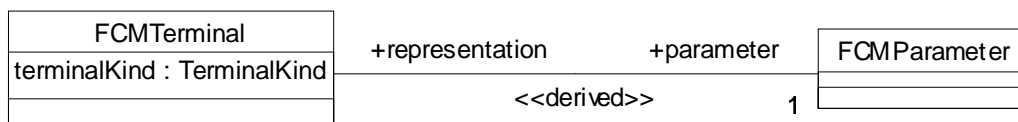

Figure 6-6 Derived association between **FCMTerminal** and **FCMParameter**

In a composite node (i.e., a node created from an **FCMComposition**) the interface offered is defined by the **FCMSource** and **FCMSink** nodes contained within the **FCMComposition**. An **FCMSource** implements (see Figure 6-2 on page 6-3) an **FCMOperation**. **FCMSink** nodes represent the population of a single output parameter of this **FCMOperation**.

6.3 EAI Specializations of the FCM

6.3.1 Motivation

Section 6.3 defines a set of specializations of the FCM. Each of these introduces a new concept required for EAI architectural modeling.

6.3.2 EAILink

Definition

Links between entities in an EAI architecture are often treated as event channels, and the occurrence of an event on such a channel initiates processing of the information associated with the event. As such, these links represent the flow of both data and control. In the FCM, data and control links are separate, so we introduce EAILink, which consists of one of each.

Links may have their synchronization specified as synchronous, in which case a link between a pair of terminals implies a synchronous (call) invocation of the relevant FCMOperation, or asynchronous in which case a link between a pair of terminals implies an asynchronous invocation of the relevant FCMOperation (the FCMOperation which owns the parameter that the terminal represents).

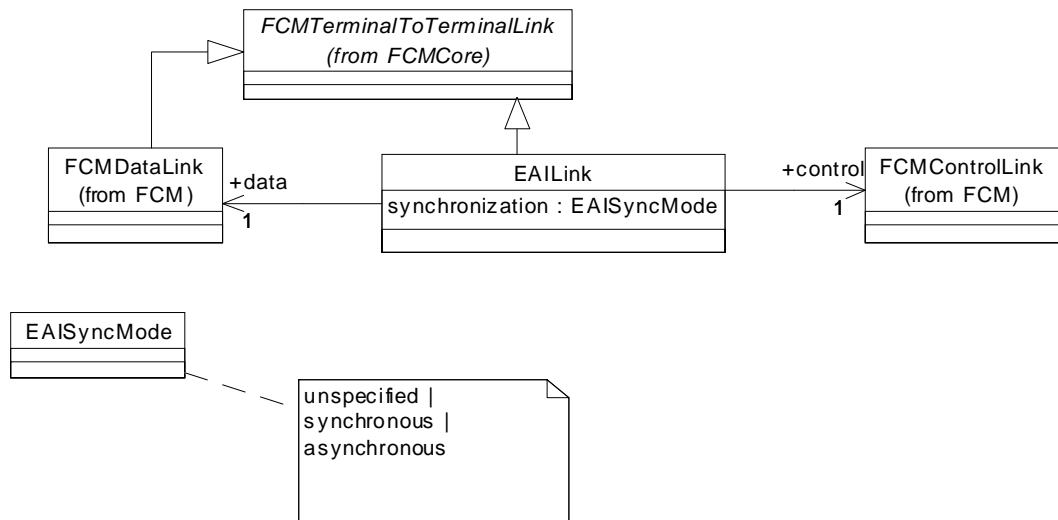

Figure 6-7 Definition of EAILink

Constraints

An instance of an EAILink between an output terminal and an input terminal implies that there is an FCMDataLink between the two terminals, and an FCMControlLink from the output terminal to the node that owns the input terminal.

6.3.3 *EAITerminal*

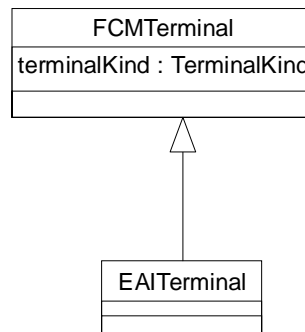

Figure 6-8 EAITerminal

Definition

An EAITerminal is a specialization of FCMTerminal.

Constraints

EAITerminal can be connected to other instances of terminals only via instances of EAILink.

An EAITerminal is the representation (see Figure 6-6) of an FCMParameter that is of type EAIMessageContent.

An EAITerminal on the exterior of a node constructed from an FCMComposition has a derived association with a single source or sink.

6.3.4 *EAIMessageContent*

Description

EAIMessageContent gives a generic metamodel for message content. Messages may have multiple parts, which may be nested. Each message part may have two distinct elements:

1. A message header which contains metadata about the message. This is used by the MOM infrastructure to decide how to process the message.
2. Message body, which contains the business content of the message.

The header and the body are `EAIMessageElements`. These are associated with a single `languageElement` of class `TDLangElement`

Constraints

Each message element (including the message header) conforms to a `messageFormat` specification, which may be physically manifest in the message (as, for example, with an inline XML DTD) or may need to be inferred by the MOM infrastructure. Distinctions of this kind may be made by designation of the `messageDomain` (e.g., generic DTD, external schema or COBOL copy book).

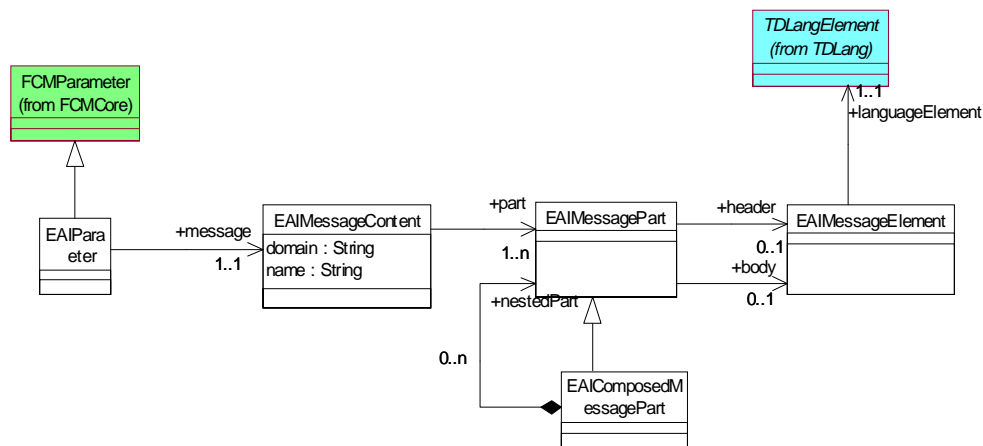

Figure 6-9 EAI MessageContent

6.3.4.1 EAIMessageElement Format Specification

The format of a message element is defined in the MessageContent metamodel by its association to a `TDLangElement`, which is a class in the CAM (see Chapter 7). This link into the CAM provides all of the following for message elements:

1. The `TDLang` metamodel provides an abstract view of the message element's structure. It may be used to represent both primitive and more complex data structures.
2. `TDLang` provides access to the language-specific representation of the message element (via the COBOL, PL/I, and other language metamodels in CAM), as well as its physical wire format (via the Type Descriptor Metamodel in CAM).

6.3.4.2 EAIHeader

`EAIHeader` is a subclass of `EAIMessageElement`; it has two associations to `EAIMessageElement`;

- `replyTo`: an `EAIMessageElement` that is required to specify the terminal to which replies to an instance of a message should be sent.
- `exceptionTarget`: an `EAIMessageElement` that is required to specify the terminal to which exception notices should be sent.

The requirement that `EAIHeader` should specify the information required to locate `replyTo` and `exceptionTarget` terminals is recorded via derived associations with `EAITerminal`. These derived associations do not form part of the message itself.

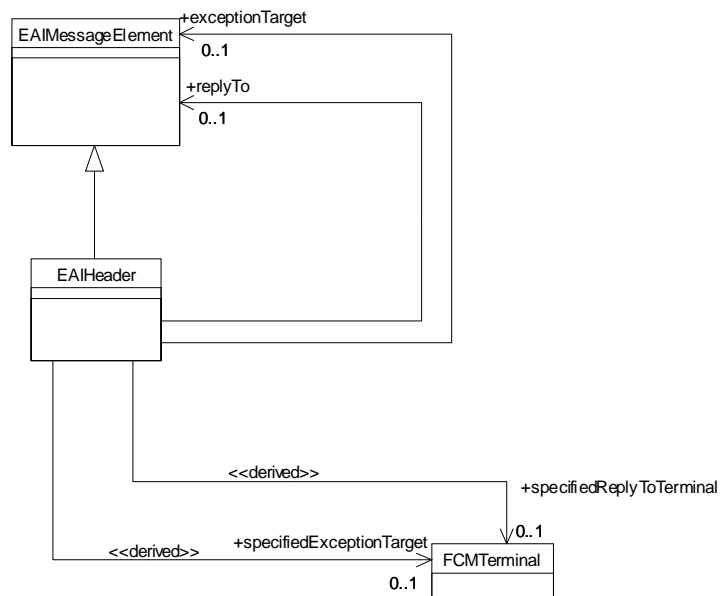

Figure 6-10 `EAIHeader`

6.3.4.3 `EAIExceptionNotice`

This is message that is sent by the MOM infrastructure if some exception occurs in processing a message. An instance of an `ExceptionNotice` will normally contain the original message, with additional exception-specific information in a separate message part.

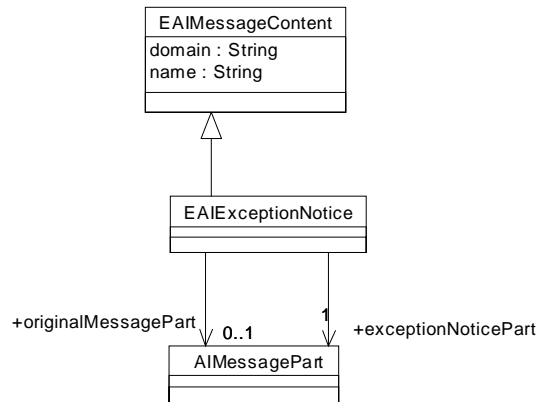

Figure 6-11 EAIExceptionNotice

6.3.4.4 XML Message Elements

Message elements can be data structures defined by traditional language specifications like COBOL and PL/I. They can also be XML documents, for which the natural specification language is XML Schema. The OMG XMI Production of XML Schema submission provides an XML Schema Metamodel. Figure 6-12 shows a linkage between the XML Schema Metamodel and the TDLang Metamodel that supports XML Schema as a specification language for message elements.

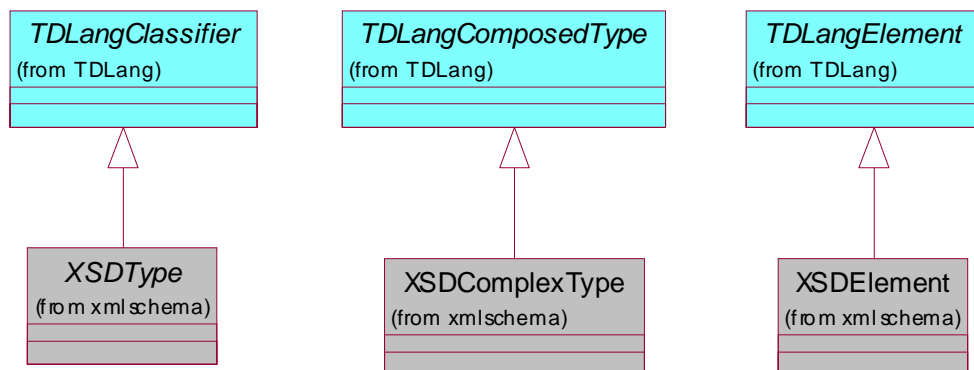

Figure 6-12 XML message elements

6.3.5 *EAMessageOperation*

Description

EAMessageOperation is a subclass of FCMOperation used to describe operations for which all the inputs and outputs are messages.

Constraints

Every input and output of an EAMessageOperation is an EAIPParameter that has a 1:1 relationship with EAMessageContent or a subclass of EAMessageContent.

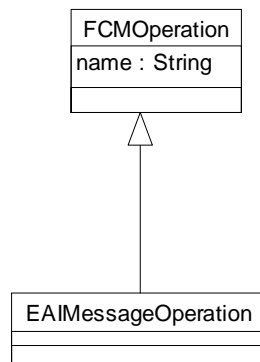

Figure 6-13 MessageOperation

6.3.6 *EASource and EASink*

Description

EASource and EASink represent points in an EAI architecture where messages appear (EASource) and disappear (EASink).

Sources and sinks may make use of EAIResources. An EAIResource represents a usable and sharable entity such as a queue (Section 6.3.7, “EAIQueue,” on page 6-12) or a database (Section 6.4.1.5, “EAIDBTransformer,” on page 6-26).

Constraints

EASource is a subclass of FCMSource. Its sinks must be EASink, and its implements operation must be an FCMOperation.

EASink is a subclass of FCMSink. Its source must be an EASource.

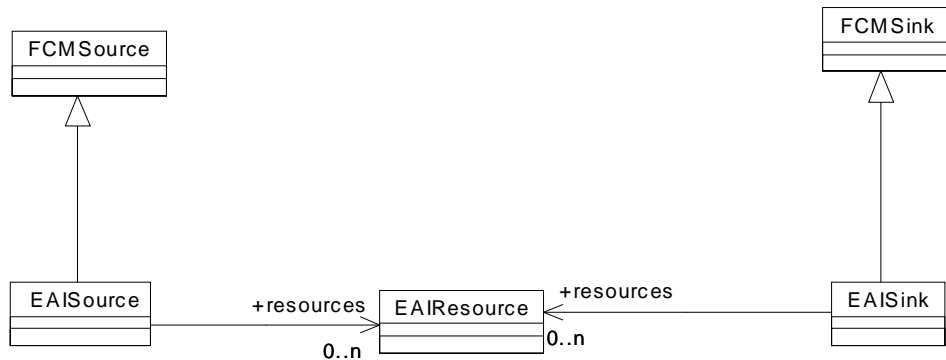

Figure 6-14 Sources and sinks

6.3.7 EAIQueue

Description

EAIQueue is a queue of finite length, and is modeled as a subclass of EAIResource.

EAIQueue has an ordered collection messages of EAIMessageContent. A queue has a name, and the maximum number of messages it can hold is specified by maxLength.

EAIQueue is intended to be an abstraction of queuing infrastructure. We note that most MOM implementations allow machine-to-machine communication via a remote queuing infrastructure that can specify a number of different queue types and relationships between them. This can be modeled as refinement or realization of EAIQueue or (see Section 6.4.1.2, “EAIStream,” on page 6-23) of the EAIPrimitiveOperator EAIStream.

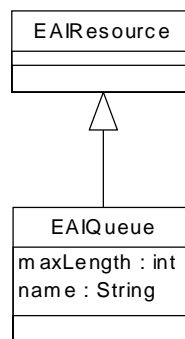

Figure 6-15 EAIQueue

Constraints

maxLength >= messages->size()

6.3.8 EAIQueuedInputTerminal and EAIQueuedOutputTerminal

A common means of implementing an asynchronous link between a pair of entities in EAI is for them to share a queuing infrastructure. In this case, the entity in which an event occurs places a message into a queue and then continues processing. The entity that is to act on this information can remove the message from the queue at any time. This normally involves the receiving entity doing one of the following:

1. Polling the queue for the arrival of a message
2. Blocking execution awaiting the arrival of a message
3. Being triggered by the arrival of a message

We represent the fact that an Operator uses queuing via the use of EAIQueuedInputTerminal and EAIQueuedOutputTerminal, which are subclasses of EAITerminal.

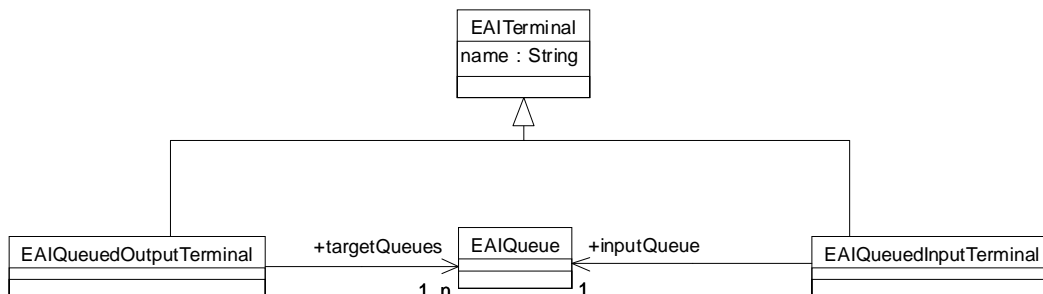

Figure 6-16 EAIQueuedOutputTerminal and EAIQueuedInputTerminal

An EAIQueuedInputTerminal has an association with the single queue that it reads from, while an EAIQueuedOutputTerminal has an association with each of the queues used by its target EAIQueuedInputTerminals.

Any operator that has an EAIQueuedOutputTerminal is understood to place a single copy of its output message on each of its targetQueues.

Queued input and output terminals may be used on any of the EAI constructs that have terminals (EAIPrimitiveOperator, EAICompoundOperator, EAISource, EAI Sink).

Constraints

All EAILinks from an EAIQueuedOutputTerminal must be instances of EAIQueuedInputTerminal.

The EAILink from an EAIQueuedOutputTerminal to an EAIQueuedInputTerminal must have synchronization=asynchronous.

An EAILink between an EAIQueuedOutputTerminal and an EAIQueuedInputTerminal implies that the inputQueue of the inputTerminal is in the targetQueues of the output terminal.

All EAIQueuedInputTerminals have EAILinks with all EAIQueuedOutputTerminals that use the same queue instance.

6.3.9 EAIQueuedSource and EAIQueuedSink

Description

EAIQueuedSource and EAIQueuedSink are used to model the internal elements of an EAIMessageFlow (see Section 6.3.10.4, “Exposing terminals in an EAIMessageFlow,” on page 6-17) that is associated with EAIQueuedInputTerminals and EAIQueuedOutputTerminals.

When viewing the internals (i.e., the EAIMessageFlow) of a CompoundOperator, the element of the flow that receives messages (and passes them on to the rest of the flow) is a source of messages to the rest of the EAIMessageFlow, and vice versa. Hence, the part that reads from a queue is modeled as a EAIQueuedSource and the part that writes to a queue as EAIQueuedSink.

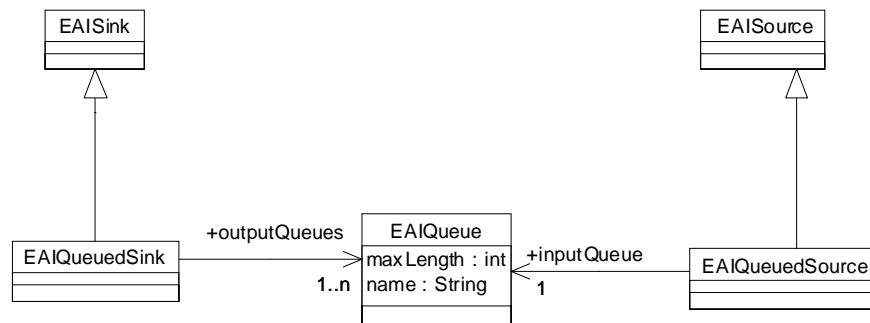

Figure 6-17 QueuedSource and QueuedTarget

Note that EAIQueuedSink and EAIQueuedSource could themselves be specialized to use queued terminals. This would imply that queueing is used both outside and inside the EAIMessageFlow.

Constraints

The outputQueues of an EAIQueuedSink must be the same as the targetQueues of the EAIQueuedOutputTerminal that it is associated with.

The inputQueue of an EAIQueuedSource must be the same as the inputQueue of the EAIQueuedInputTerminal that it is associated with.

Refinement relationships

An EAILink with synchronization of unspecified is refined by an EAILink with synchronization of either synchronous or asynchronous.

Where there is an instance of an EAILink with a synchronization of asynchronous linking a pair of FCMTerminals, this is refined by the substitution of EAIQueuedInputTerminal and EAIQueuedOutputTerminal for the FCMTerminals.

6.3.10 Operators

Operators act upon messages as they flow between systems. We define EAIPrimitiveOperator to be a subclass of FCMFunction, which invokes an EAIMessageOperation. Subclasses of EAIPrimitiveOperator are used to represent particular types of message processing behavior.

We define CompoundOperator to represent the behavior of compositions of operators. This document defines subclasses of either kind of operator that perform specific kinds of operation on a message. Message operations may act on the message header and body and may change their content, their format or both. They may also provide routing behavior.

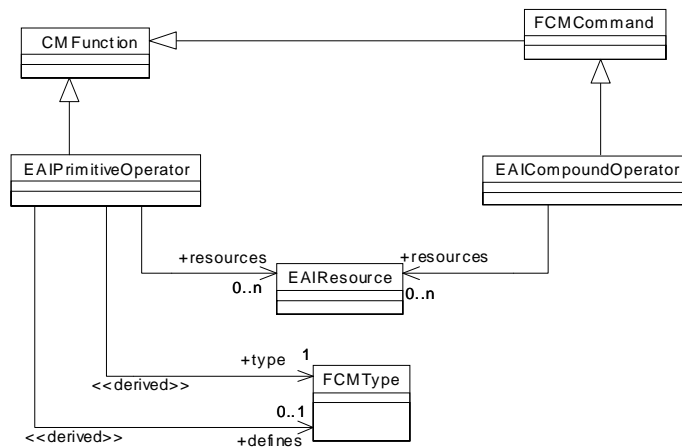

Figure 6-18 Definitions of PrimitiveOperator and CompoundOperator

6.3.10.1 *EAIPrimitiveOperator*

Description

Instances of *EAIPrimitiveOperator* enact a simple message processing operation. It is 'opaque' in that its operation is specified but its internal workings are not modeled. It may optionally make use of *EAIResources* to enact the operation.

Constraints

The *EAIPrimitiveOperator* invokes an *EAIMessageOperation*.

EAIPrimitiveOperator has a derived association type with *FCMType*. It subclasses *FCMFunction*, which invokes an *FCMOperation*. *FCMOperation* is composed by *FCMType*.

When used in an *EAIMessageFlow*, an *EAIPrimitiveOperator* also defines a type.

6.3.10.2 *EAICompoundOperator*

Description

An instance of an *EAICompoundOperator* composes more complex message processing behavior from *EAIPrimitiveOperators*, from other *EAICompoundOperators* or both. It may optionally make use of *EAIResources* to enact its operations.

Constraints

EAICompoundOperator can only compose *EAIPrimitiveOperator* or other *EAICompoundOperators*. The *implementingComposition* (a derived association inherited from *FCMCommand*, see Figure 6-19) must be an *EAIMessageFlow*.

6.3.10.3 *EAIMessageFlow*

An *EAIMessageFlow* is a subclass of *FCMComposition*. Each of its nodes (see Figure 6-2 on page 6-3) must be one of the operator classes (*EAIPrimitiveOperator* or *EAICompoundOperator*), and its connections must be *EAILinks*. In addition it allows nodes to have explanatory annotations attached to them.

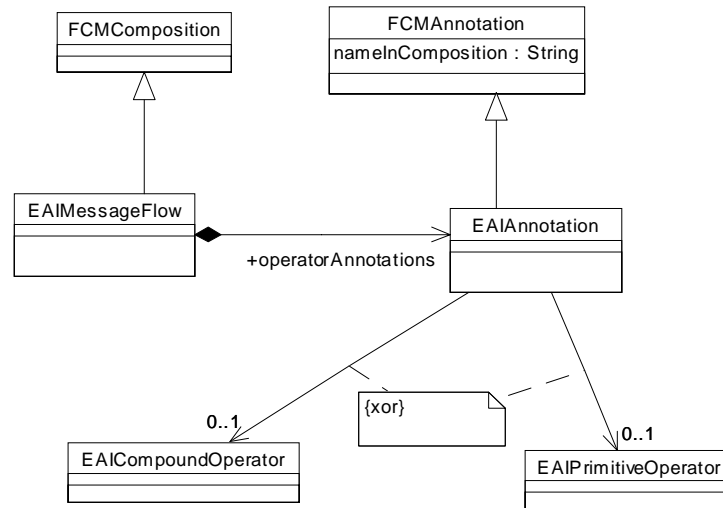

Figure 6-19 EAIMessageFlow

6.3.10.4 Exposing terminals in an EAIMessageFlow

When forming an EAICompoundOperator from EAIPrimitiveOperators, the means of connecting the external representation of an FCMCommand (i.e., its terminals) to the FCMComposition that implements it is via FCMSource and FCMSink nodes. These jointly define the input and output parameters of the composite node, and consequently the input and output terminals of the EAICompoundOperator.

An input EAITerminal in a FCMComposition can be 'exposed' by attaching an EAISource to it via an EAILink. The message type of the input terminal to be exposed determines:

- The type of the output terminal of the EAISource
- The type in the (single) input parameter to the implements FCMOperation

This consequently determines the type of that the external EAITerminal represents. We introduce a derived association promotedTerminal from EAITerminal to EAITerminal that models this relationship between a terminal on the interior of a composite node and a terminal on its exterior.

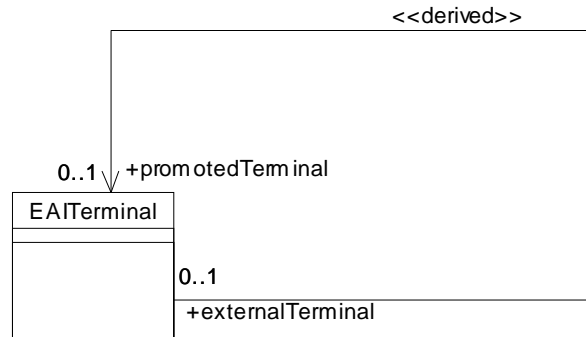

Figure 6-20 Derived association between a terminal inside a composite node and the corresponding terminal outside

Constraints

The `promotedTerminal` and the `externalTerminal` represent `FCMParameters` that have the same type.

6.3.11 Adapters

An integration architecture provides paths for the flow of messages between the systems being integrated. Adapters provide the points at which the message-flow paths are actually connected to those systems. An adapter converts a specific kind of message from some system-specific format into a specified message-content type, or vice versa. `EAIAdapter` is modeled as a specialization of `FCMFunction`.

6.3.11.1 *EAI*SourceAdapter

An `EAI`SourceAdapter obtains information from a system, translates it into (some subclass of) `EAI`MessageContent and then sends it. Source adapters are modeled as a subclass of `FCMFunction`. The mapping between the internal format and the message is specified by an `internalToMessage` `FCMMapping`.

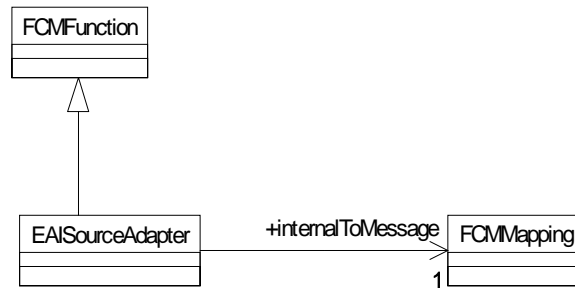

Figure 6-21 SourceAdapter

Constraints

The output terminals of a SourceAdapter are instances of EAITerminal

Output parameters of the invokes FCMOperation of SourceAdapter must be EAIParameters, which are associated with EAIMessageContent.

There is no constraint on the type of input terminals.

There is no constraint on the type of input and fault FCMPParameters. It is noted that the faults FCMPParameters may be EAIParameters (with EAIMessageContent) but that this is unlikely to be the case for input because adapters are used to link messaging to other (internal) interfaces.

6.3.11.2 EAITargetAdapter

An EAITargetAdapter has a single input EAITerminal ("in"). It receives a message with content of a given input type, maps the message content to the format required for a system and then delivers the information to the system. The transformation is specified by a messageToInternal FCMMapping.



Figure 6-22 EAI Target Adapter

Constraints

The input parameters of the FCFunction that EAITargetAdapter invokes must be EAIParameters (with associated EAIMessageContent).

There is no constraint on whether the outputs and faults of the invokes FCFunction are FCParameters or EAIParameters. However, they are unlikely to have associated EAIMessageContent because adapters are used to link messaging to other (internal) interfaces.

6.3.11.3 EAICallAdapter

An EAICallAdapter is invoked synchronously by an application that wishes to make use of a service made available via a server; the server accepts a request message and sends a response message back to the service requester. It has two input terminals:

- call": an FCMTerminal that a requesting application can use to invoke the call adapter
- handleReply": an EAITerminal that handles a reply

It has two output terminals:

- request": the EAITerminal from which the request message is sent
- out": an FCMTerminal to which the reply message is mapped

EAICallAdapter is a subclass of FCFunction.

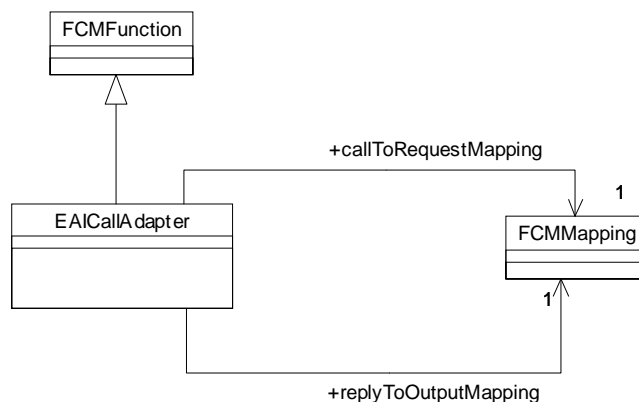

Figure 6-23 EAICallAdapter

The call adapter has two mappings, one of which specifies how the call input parameters are mapped to the request message; the other specifies how the return message is mapped to output parameters represented by the "out" terminal.

When invoked via its "call" terminal, the EAICallAdapter maps the call parameters into a request message and sends it to the input terminal of an EAIRquestReplyAdapter. It waits for a reply. On receipt of a reply it maps the message as specified in the replyToOutputMapping, and puts out the result on the "out" terminal.

Constraints

The "out" terminal of EAICallAdapter must be connected via an EAILink to the "requestIn" terminal of an EAIRquestReplyAdapter.

The "handleReply" terminal of EAICallAdapter is the target of connections via an EAILink from the "replyOut" terminal of an EAIRquestReplyAdapter.

6.3.11.4 *EAIRquestFormat*

EAIRquestFormat is a subclass of EAIMessageContent. A message that conforms to EAIRquestFormat specifies a terminal to which replies should be sent (specifiedReplyTerminal). The association with the terminal is not explicit in the message but may be computed from information in the message.

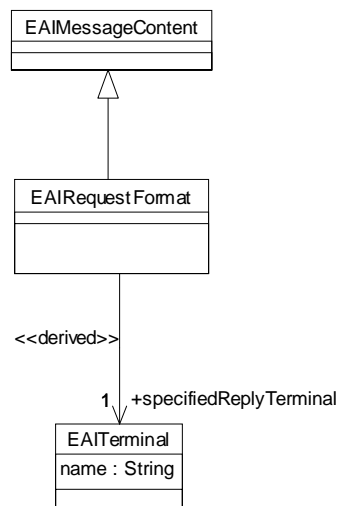

Figure 6-24 EAIRquestFormat

6.3.11.5 *EAIRquestReplyAdapter*

An EAIRquestReplyAdapter is a subclass of FCMCommand. It has a single input terminal "requestIn" and a single output terminal "replyOut".

On receipt of a message that conforms to the EAIRequestFormat, it maps the request message into the format required by the system it interfaces to, calls an operation on that system, synchronously receives a result, and formats the result for return to the "handleReply" terminal specified in the request message.

This effectively creates dynamic and temporary instances of EAILink between the "replyOut" terminal and the "handleReply" terminal of the EAICallAdapter that sent the request message.

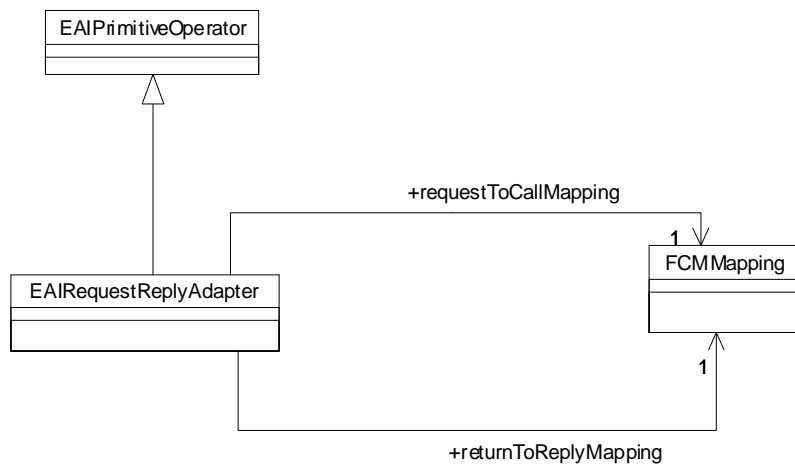

Figure 6-25 EAIRequestReplyAdapter

Constraints

The "requestIn" terminal expects to receive a message of that conforms to EAIRequestFormat.

6.4 Kinds of Operator

6.4.1 Operators

We define several specializations of EAIPrimitiveOperator and EAICompoundOperator. EAICompoundOperators combine more than one of the primitive EAI concepts represented by the PrimitiveOperators. Implementations of them do not need to follow this internal representation, provided that they obey the signature (in terms of the messages they receive and send) and the documented semantics.

6.4.1.1 EAIFilter

An EAIFilter is a subclass of EAIPrimitiveOperator.

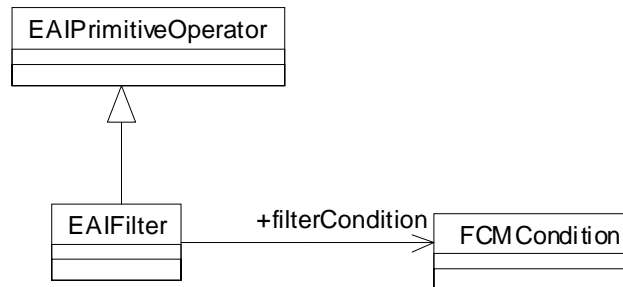

Figure 6-26 Filter

A filter's output is a copy of its input. No output occurs if the input message does not satisfy the filter condition.

6.4.1.2 EAISStream

EAISStream is an operator that allows 'quality of service' on a communication channel to be expressed.

The flow of control and data via EAILink between EAITerminals assumes that messages are always received in the order that they are sent and that there is basically no delay in their transmission.

In some implementations, a stream of messages may be received in a different order from that in which they are sent, and they may be received at a different rate from that at which they are sent. An EAISStream operator can be used to model this.

An EAISStream can be used to model reordering of incoming messages by maintaining a buffer.

In an implementation, an incoming message is may be added to the buffer in a place determined by the streaming algorithm. An outgoing message may be sent at the same or different time as an incoming message is received. The streaming algorithm determines when to place messages from the top of the buffer onto the "out" terminal. Typically, this will be when the buffer contains a sufficient block of messages in the correct order.

All of this behavior is abstracted via an emissionCondition that determines under what circumstances a message is emitted from the stream. The message emitted may be any element of the buffer. Once emitted from the stream, the message is removed from the buffer.

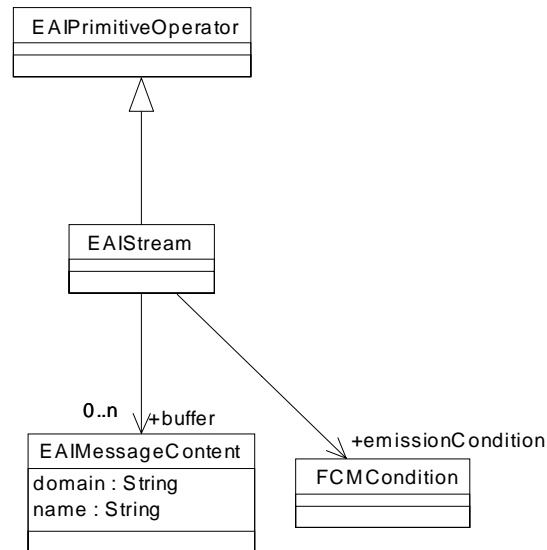

Figure 6-27 Stream

6.4.1.3 *EAIPostDater*

`EAIPostDater` is a subclass of `EAISStream` with a single input terminal ("in") and a single output terminal ("out").

On receipt of a message at its input terminal, it adds the message to the buffer, and creates an individual `timingCondition` for it. The `timingCondition` may entail a derivation from the content of the input message by a `timerMapping`. `EAIPostDater` holds the message until its individual timing condition is met, then emits it from its "out" terminal.

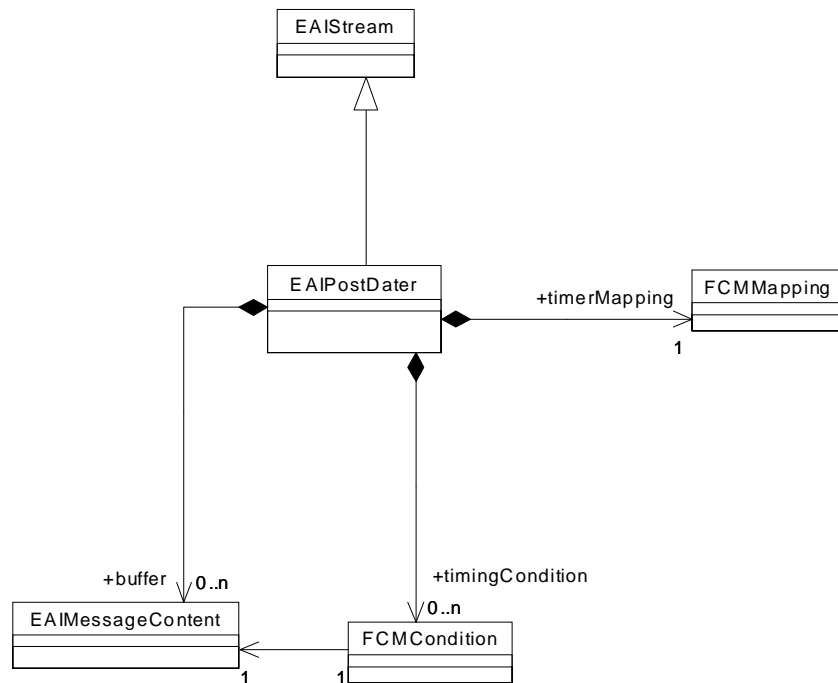

Figure 6-28 EAIPostDater

6.4.1.4 EAITransformer

A Transformer is a subclass of PrimitiveOperator with a single input terminal and a single output terminal.

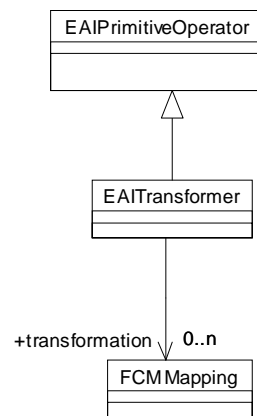

Figure 6-29 Transformer

The output message is a transformation of the input message, as dictated by the transformation FCMMapping.

6.4.1.5 *EAIDBTransformer*

An EAIDBTransformer is a subclass of EAITransformer that has access to an EAIDatabase.

EAIDatabase is modeled as a subclass of EAIResource and has the property `databaseName`. Subclasses of EAIDatabase may specify further properties such as information required to connect to the database.

Access to a database as a resource allows the transformation to make use of information contained in the database. In particular, it allows the message to be augmented (or enriched) with data from the database.

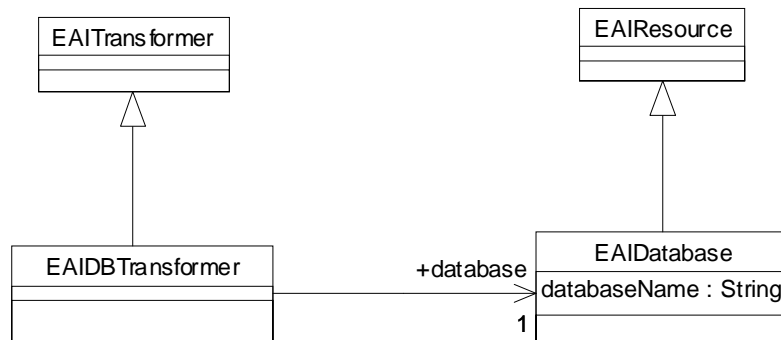

Figure 6-30 EAIDBTransformer

6.4.1.6 *EAIAggregator*

An EAIAggregator is a subclass of PrimitiveOperator. It has a single input terminal ("in") and a single output terminal ("out"). Its purpose is to combine several messages (comprising an aggregate) into a single output message (EAIMessageAggregation). It is commonly used in conjunction with EAITimer, which can check for deadlines.

On receipt of a message, if there are no existing message aggregates, the aggregator creates one and adds the message to it.

On receipt of a subsequent message, the aggregator examines each existing aggregate, evaluating the `addToAggregate` condition (which will depend on the message header or body contents). If an aggregate exists for which `addToAggregate` evaluates to true, then the message is added to it.

Each time a message is added to an aggregate, the aggregateComplete condition is evaluated. If it evaluates to true, then a message is constructed from the messages it holds and is sent on the output terminal. The mapping from the messages contained in the aggregate to the message sent is specified by the aggregationMapping.

If the aggregateComplete condition does not evaluate to true, then no message is sent.

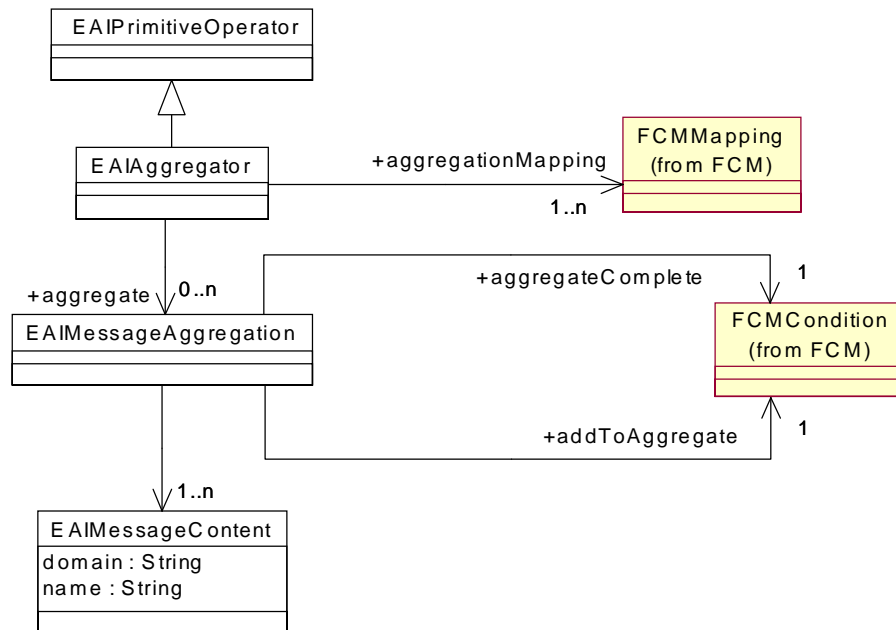

Figure 6-31 EAIAggregator

6.4.1.7 EAIRouter

Description

When a router receives a message, it resends a copy via its single output terminal so that all connected input terminals receive the message. In addition, a router can accept dynamic addition or removal of target terminals, and so it can be used to model a simple publication channel for messages.

Modeling

EAIRouter is modeled as an EAICompoundOperator. The composition that defines an EAIRouter contains an EAIRouterUpdate and an EAIBroadcaster operator. It has the constraint that they share the same instance of EAIRoutingTable.

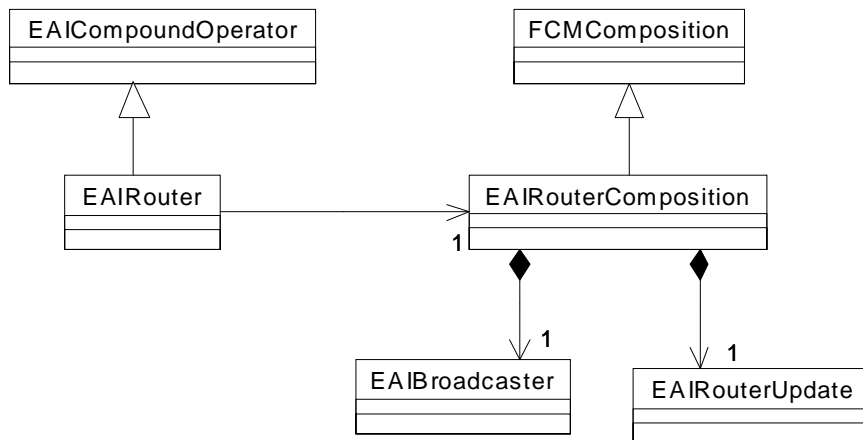

Figure 6-32 EAIRouter

6.4.1.8 EAIRouterUpdate and EAIBroadcaster

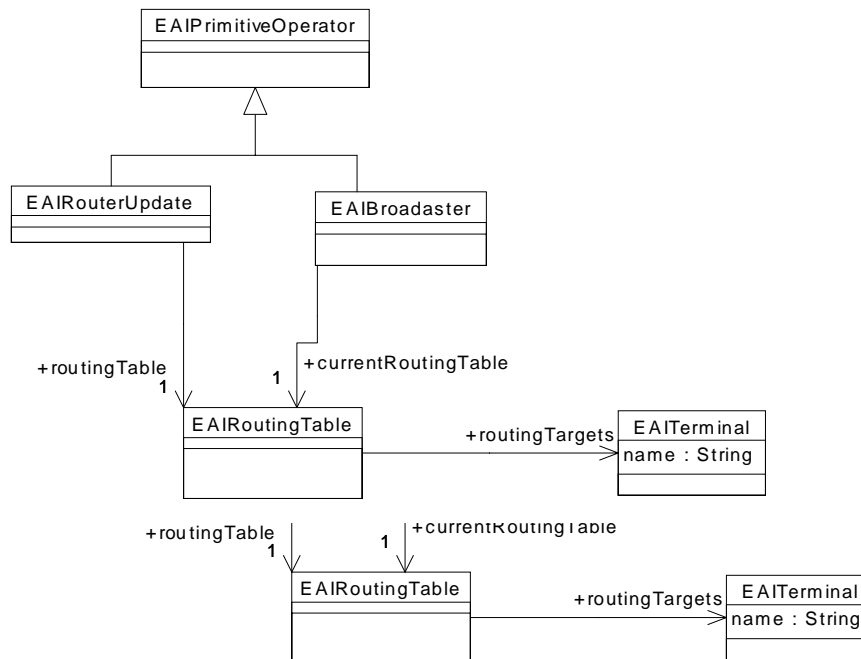

Figure 6-33 EAIRouter and EAIRouterUpdate

EAIBroadcaster routes a message to destinations listed in the EAIRoutingTable, which is maintained by EAIRouterUpdate.

EAIRouterUpdate is a primitive operator with a single input terminal ("control") and no output terminals. It expects to receive a message that conforms to the EAIRouterUpdateFormat content type. Such a message can specify either the addition (adds) or removal (removes) of a single terminal from the routing table.

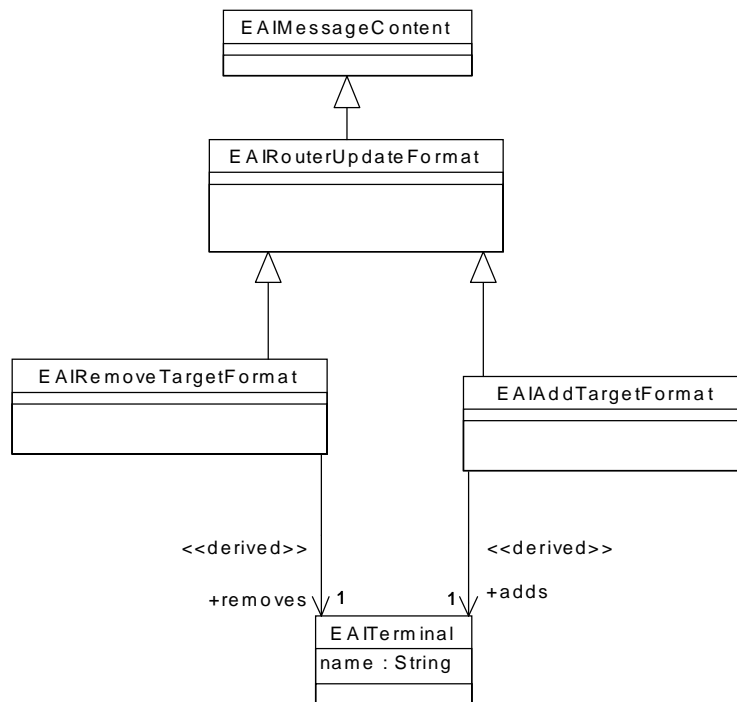

Figure 6-34 EAIRouterUpdateFormat

An EAIBroadcaster has a single input terminal ("in") and a single output terminal ("out"). The "in" terminal represents any input message. This is copied to the output terminal for routing to all connected EAITerminals. The output terminal is connected via an EAILink to each EAITerminal in the EAIRoutingTable.

6.4.1.9 EAISubscriptionOperator

An EAISubscriptionOperator is a subclass of EAIPrimitiveOperator with a single input terminal ("subscribe") and no output terminals. It expects an EAISubscriptionFormat as input. It adds a single EAISubscription to a subscriptionTable on receipt of an EAISubscriptionFormat.

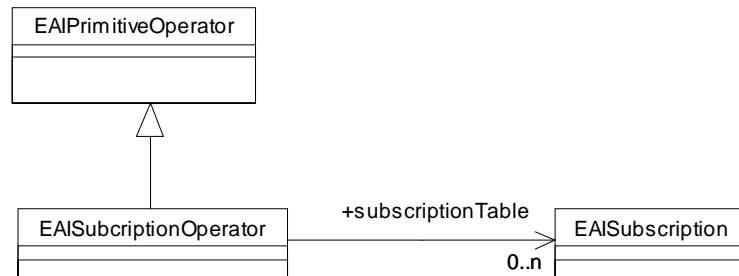

Figure 6-35 SubscriptionOperator

A message that conforms to the EAISubscriptionFormat specifies a target EAITerminal and a set of EAISubscriptionRules. In Figure 6-36, this is shown as a pair of derived associations. This indicates that the target and associated subscription rules can be computed from the message content. (There could be some indirection in the specification of the rules and terminal, indicated by subscriptionModes.)

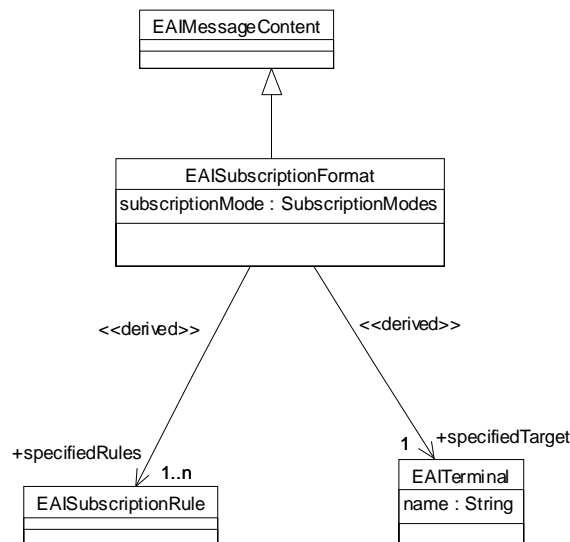

Figure 6-36 EAISubscriptionFormat

An EAISubscription relates an EAITerminal to a collection of EAISubscriptionRules. Subsequently the EAIPublicationOperator (Section 6.4.1.9) will forward messages that satisfy the subscriptionRules to the subscribingTerminal.

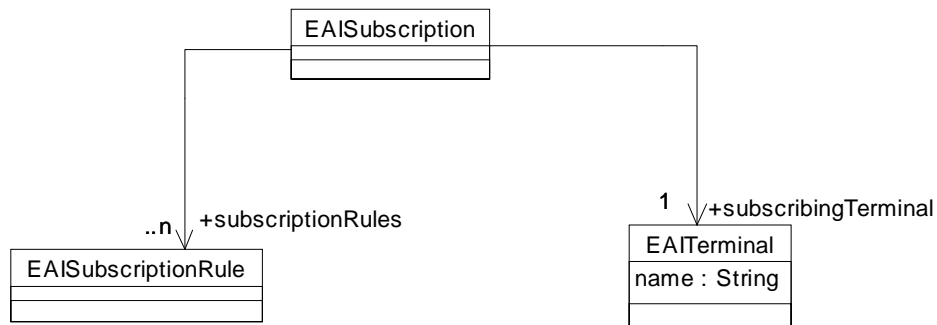

Figure 6-37 EAISubscription

An EAISubscriptionFilter is a subclass of EAIFilter. Its filterCondition is a set of EAISubscriptionRules.

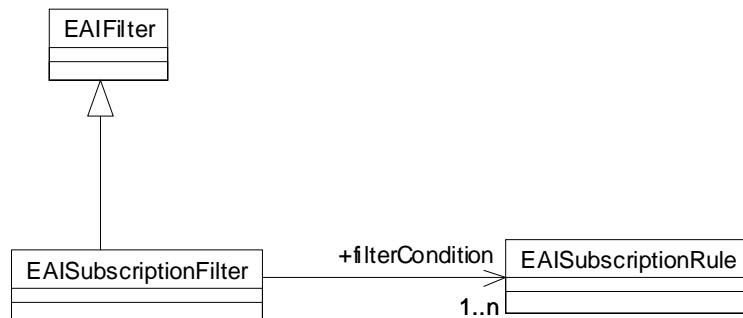

Figure 6-38 SubscriptionFilter

An EAISubscriptionRule has subclasses EAITopicRule and EAIContentRule.

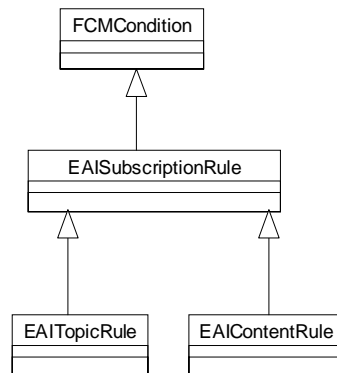

Figure 6-39 EAISubscriptionRule, EAITopicRule and EAIContentRule

6.4.1.10 EAIPublicationOperator

Description

The EAIPublicationOperator models the semantics of the publish/subscribe mode of information sharing. It forwards each message to the targets specified in its currentSubscriptions, if they pass the relevant filter.

It is modeled as a subclass of EAIPrimitiveOperator, with a single input terminal ("in"), and a single output terminal. Messages sent to the input terminal are sent from the output terminal ("out") to each subscriber (EAITerminal) if the message conforms to the EAISubscriptionRule for that subscriber.

This output behavior is not the same as that of EAITerminal, which sends a copy of the message to every target terminal. Therefore a subclass of EAITerminal is introduced called EAIPublicationTerminal.

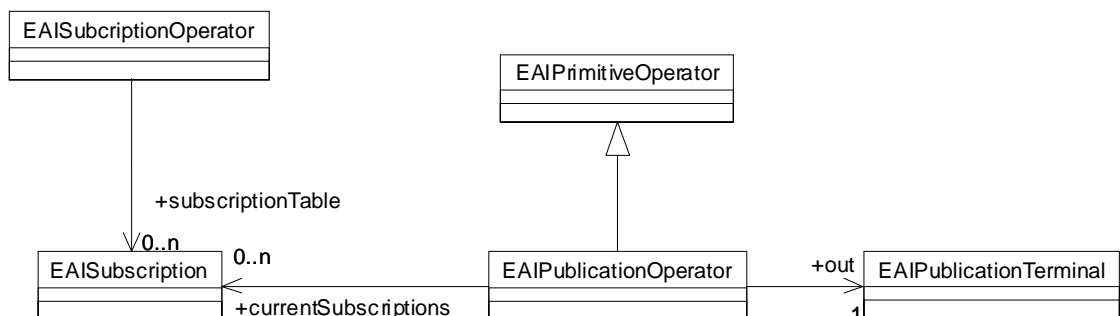

Figure 6-40 EAIPublicationOperator and EAISubscriptionOperator

The diagram below shows the instance diagram for the EAISubscriptionTable after two subscriptions have been added.

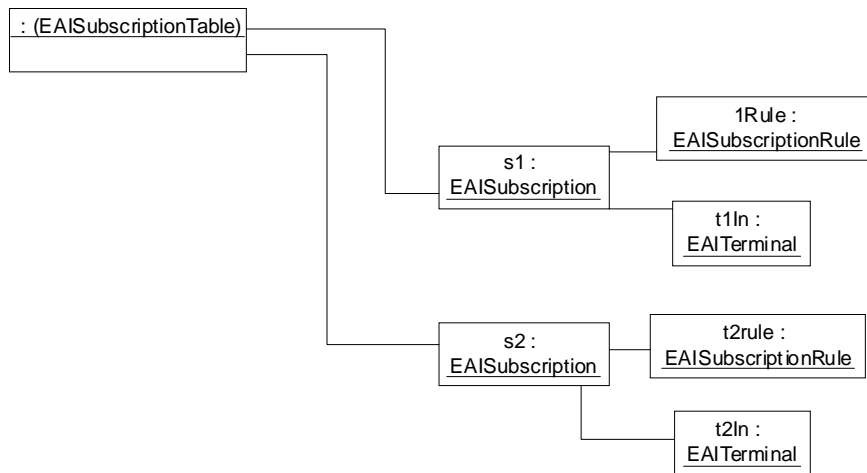

Figure 6-41 Example SubscriptionTable instance diagram

6.4.1.11 *EAITimer*

EATimeSetOperator

The TimeSetOperator is a subclass of PrimitiveOperator, with a single input terminal ("set") and zero output terminals. It processes a message (EAIMessageTimerCondition) that specifies a timerCondition and a means of identifying the messages to which the condition will apply. It uses this information to add to a list of timeSetConditions.

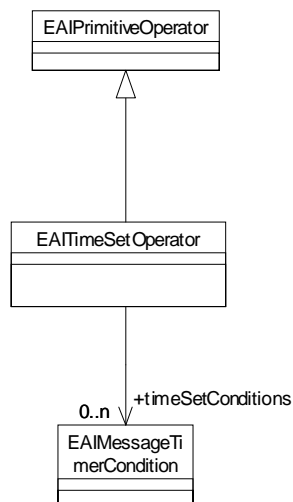

Figure 6-42 TimeSetOperator

An `EAIMessageTimerCondition` is composed of two `FCMConditions`:

- `timerCondition` specifies a deadline (a time constraint). This may be relative or absolute.
- `correlationCondition` specifies the messages to which the `timerCondition` applies. This is often a condition on an element of a message header, such as the commonly used 'correlation identifier.'

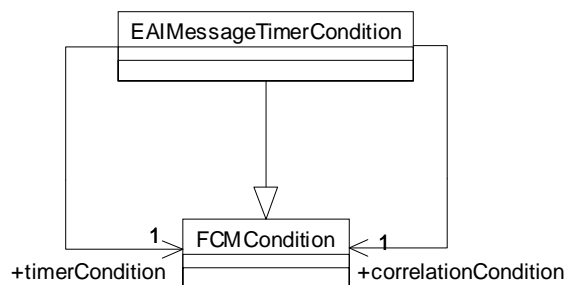

Figure 6-43 `EAIMessageTimerCondition`

Constraints

No more than one `EAIMessageTimerCondition` can apply to any single message in the `timeSetConditions`.

6.4.1.12 `EAITimeCheckOperator`

`EAITimeCheckOperator` is a subclass of `PrimitiveOperator` with a single input terminal ("check") and three output terminals ("ontime", "expiry" and "late"). On receipt of a message, it examines its set of `timeCheckConditions` to see if any of the `correlationConditions` apply. If there is a condition that applies, it checks the appropriate `timerCondition`. If the `timerCondition` is met, then the message is passed to the "ontime" terminal; if not, it is passed to the "late" terminal.

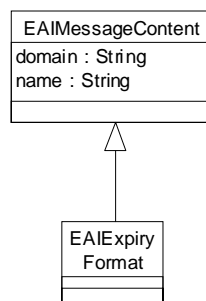

Figure 6-44 `EAIExpiryFormat`

At the time that a particular timeCheckCondition expires, a message of format EAIExpiryFormat is sent from the "expiry" terminal.

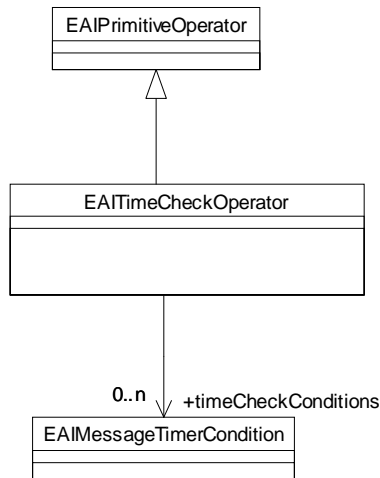

Figure 6-45 EAITimeCheckOperator

6.4.1.13 EAITimer

EAITimer is formed from a composition of EAITimeSetOperator and EAITimeCheckOperator.

It has two input terminals, "set" and "check," and two output terminals "out", "expiry" and "late", all of which map to terminals of the same name owned by the two primitive operators. Consequently, the "set" terminal causes the EAITimeSetOperator to be invoked, while messages sent to the "check" terminal cause the EAITimeCheckOperator to be invoked.

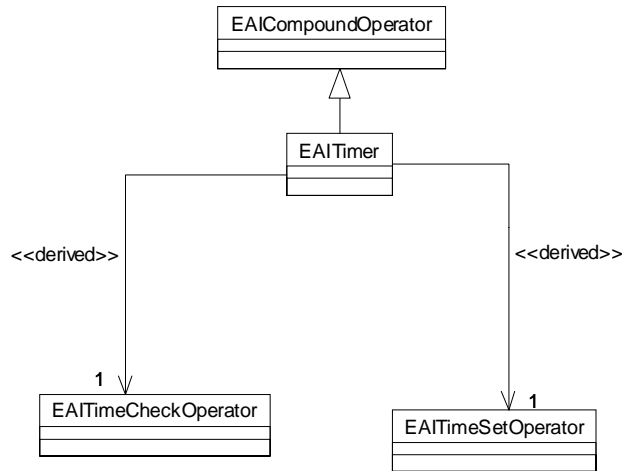

Figure 6-46

Constraints

The instance of EAITimeCheckOperator and EAITimeSetOperator from which an EAITimer is formed share the same collection of EAIMessageTimerCondition.

6.4.2 Topic-based publish/subscribe

6.4.2.1 EAITopicPublisher

An EAITopicPublisher is a subclass of EAISource. It sends messages for publication to an EAIPublicationOperator. The set of topics that it publishes messages on is denoted by publishesOn. This is a derived association, since a topic publisher need not declare the set of topic it publishes on.

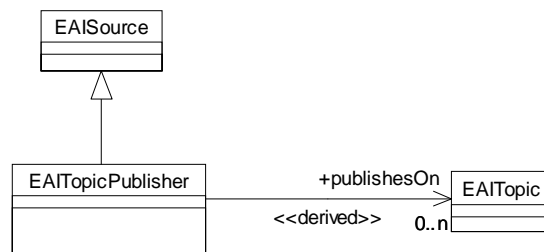

Figure 6-47

6.4.2.2 Topics 'allowed' by an EAITopicRule

An abstract representation of an EAITopicRule is the set of Topics that it allows.

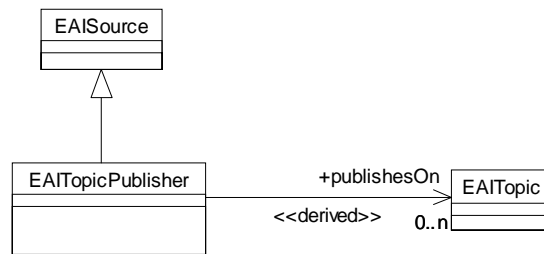

Figure 6-48 Topics allowed by an EAITopicRule

6.4.2.3 Relationship between topic-based publishers and subscribers

Topic-based publishers and subscribers are related to each other via the topics that they produce and consume.

For an input terminal representing a subscriber connected to a particular PublicationOperator, the set of topics it is interested in (subscribesTo) is determined by the topic which its filterCondition allows.

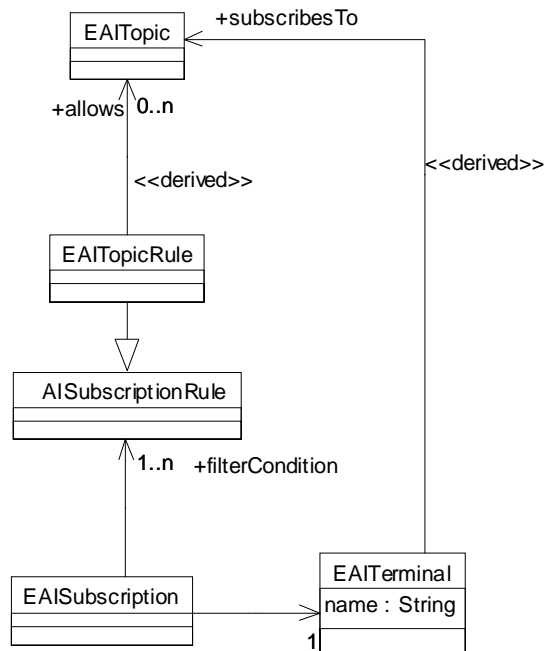

Figure 6-49 Relationship between a terminal and the topics for which it has a subscription

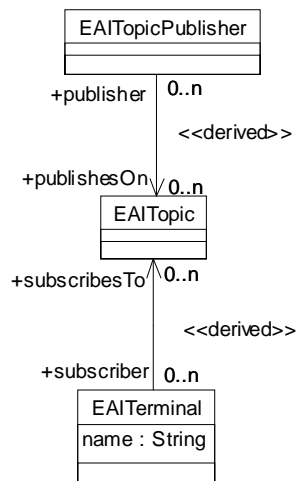

Figure 6-50 Relationship between publishers, subscribers and topics

6.5 CCA Component Library for EAI

This section specifies the CCA component library for EAI. It is an informational supplement to the EAI Integration metamodel.

For each of the listed EAI model elements a corresponding library component is defined. In each case the library component has the same name as the corresponding EAI model element.

6.5.1 Operators

6.5.1.1 EAIPrimitiveOperator

EAIPrimitiveOperator corresponds to an unconstrained CCA ProcessComponent.

The Terminal of the EAIPrimitiveOperator corresponds to Port of the CCA ProcessComponent.

Input Terminal corresponds to a CCA FlowPort with metaattribute direction = responds.

Output Terminal corresponds to a CCA FlowPort with metaattribute direction = initiates.

The handled ContentFormat of a Terminal in the EAIPrimitiveOperator corresponds to the type DataElement of the CCA FlowPort.

The Choreography of the CCA ProcessComponent corresponding to an EAIPrimitiveOperator will have CCA PortActivity. This represents each CCA FlowPort corresponding to EAI input Terminal, followed by CCA Transition with target on CCA PortActivity that represents each CCA FlowPort corresponding to EAI output Terminal.

A CCA ProcessComponent, corresponding to an EAIPrimitiveOperator, can be utilized in a CCA Composition as a CCA ComponentUsage that uses the CCA ProcessComponent. For each CCA Port in the CCA ProcessComponent, there will be a CCA PortConnector corresponding to the CCA FlowPort of the used ProcessComponent.

In CCA, there is no fundamental distinction between primitive and non-primitive ProcessComponents. Rather, the "primitiveness" of a ProcessComponent is not externally observable. The CCA ProcessComponent may optionally have internal Composition detail, using other ProcessComponents.

In CCA, there is no fundamental distinction between primitive and non-primitive ProcessComponents. Rather, the "primitiveness" of a ProcessComponent is not externally observable. The CCA ProcessComponent may optionally have internal Composition detail, using other ProcessComponents.

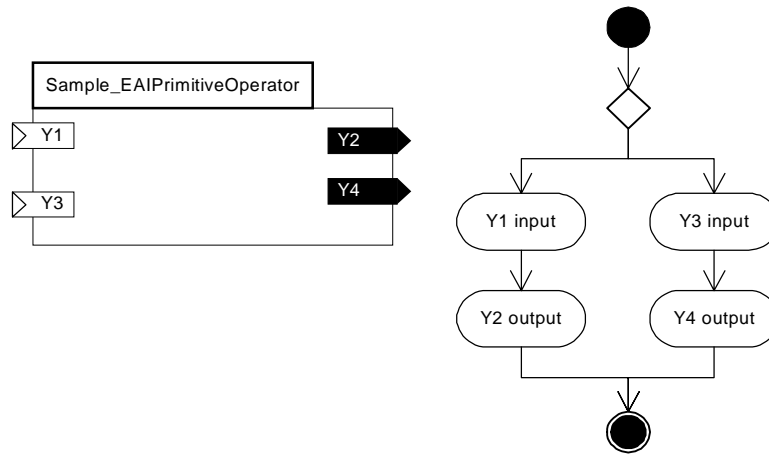

Figure 6-51 CCA notation for a sample generic EAIPrimitiveOperator

6.5.1.2 EAITransformer

EAITransformer is a specialized EAIPrimitiveOperator. It corresponds to a CCA ProcessComponent with one CCA FlowPort with direction = responds and one CCA FlowPort with direction = initiates.

The Choreography of the CCA ProcessComponent corresponding to an EAITransformer will show a CCA PortActivity on the FlowPort with direction = responds, followed by a CCA PortActivity on the FlowPort with direction = initiates.

The input and output CCA FlowPort will have different DataElement types. The ProcessComponent will transform from the input DataElement type to the output DataElement type.

The transformation to be performed on the DataElement contents can be specified in a Property of the CCA ProcessComponent as an expression, script or transformation specification in any of the transformation languages available. Alternatively, the transformation can be delegated into usages of other technology-specific transformation ProcessComponents in the internal Composition.

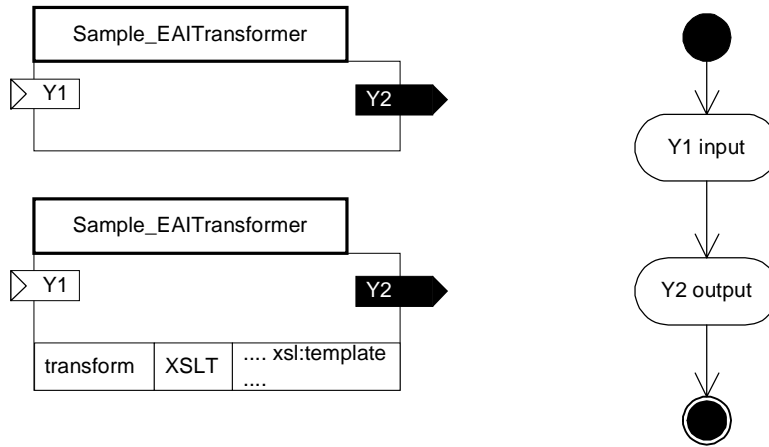

Figure 6-52 CCA notation for sample EAITransformer

6.5.1.3 EAIFilter

EAIFilter is a specialized EAIPrimitiveOperator. It corresponds to a CCA ProcessComponent with one CCA FlowPort with direction = responds and two CCA FlowPort with direction = initiates.

The Choreography of the CCA ProcessComponent corresponding to an EAIFilter will show a CCA PortActivity on the FlowPort with direction = responds, followed by a choice vertex, followed by a CCA PortActivity on each of the FlowPort with direction = initiates.

The input and each output CCA FlowPort will have the same DataElement type.

The criteria for the choice of true or false output terminal Port can be specified in a Property of the CCA ProcessComponent as an expression in any of the languages available. Criteria logic can also be delegated into usages of other ProcessComponents in the internal Composition.

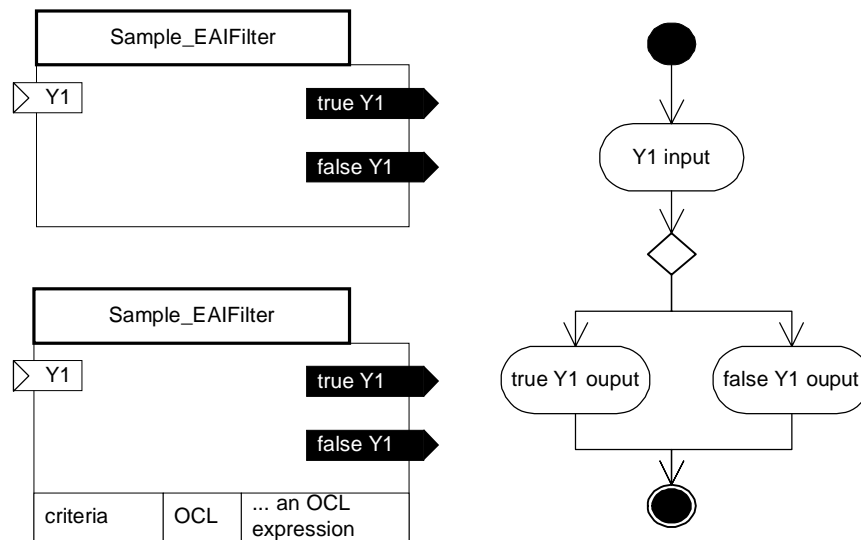

Figure 6-53 CCA notation for a sample EAIFilter

6.5.1.4 EAStream

EAStream is a specialized EAPrimitiveOperator. It corresponds to a CCA ProcessComponent with a single CCA FlowPort with direction = responds and a single CCA FlowPort with direction = initiates.

The Choreography of the CCA ProcessComponent corresponding to an EAStream will show a CCA PortActivity on the FlowPort with direction = responds, followed by a Fork, followed by CCA PortActivity on the FlowPort with direction = initiates, followed by a Join.

The input and output CCA FlowPort will have the same DataElement type. The ProcessComponent will store inputs to be sent later, possibly in a different order, through the output terminal FlowPort.

The algorithm used to determine when, and in which order, the incoming messages will be posted in the output terminal FlowPort can be specified as a Property of the EAStream component, or it can be delegated into usages or other ProcessComponents in the internal Composition.

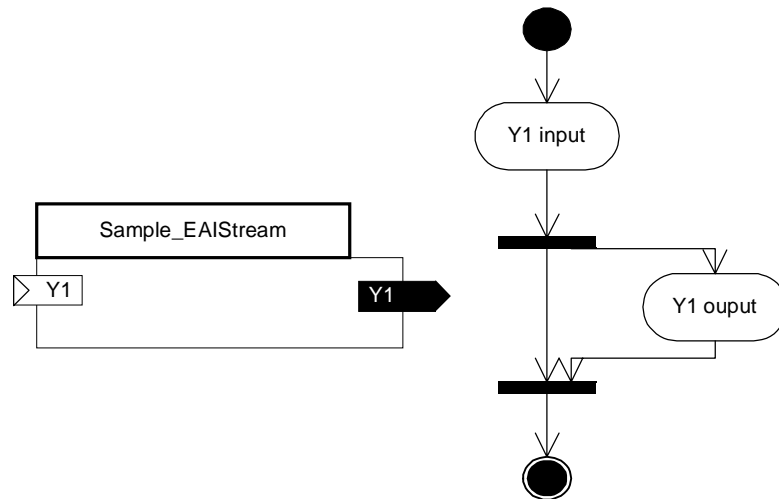

Figure 6-54 CCA notation for a sample EAISStream

6.5.1.5 EAICompoundOperator

EAICompoundOperator corresponds to an unconstrained CCA component. It will use other EAI Operator or Adapter ProcessComponents in the internal Composition.

The ProcessComponent for EAICompoundOperator will have externally connectable Ports that will be delegated into Ports of the internally used ProcessComponent.

Incoming messages on the external Port of the EAICompoundOperator ProcessComponent will be delivered to the internally connected Port of the ProcessComponent operators and adapters used.

Outgoing messages from the internally connected Port of the used ProcessComponent operators and adapters will be forwarded to the external outgoing Port of the EAICompoundOperator ProcessComponent.

This recursive composition capability of CCA corresponds to FCM and EAI recursive composition of nodes, operators and adapters.

For the user of an EAICompoundOperator ProcessComponent, there is no difference between using a Compound or a Primitive Operator. The internal composition of the Compound Operator remains encapsulated by the ProcessComponent. The user can only observe the external Port and Choreography of the ProcessComponent.

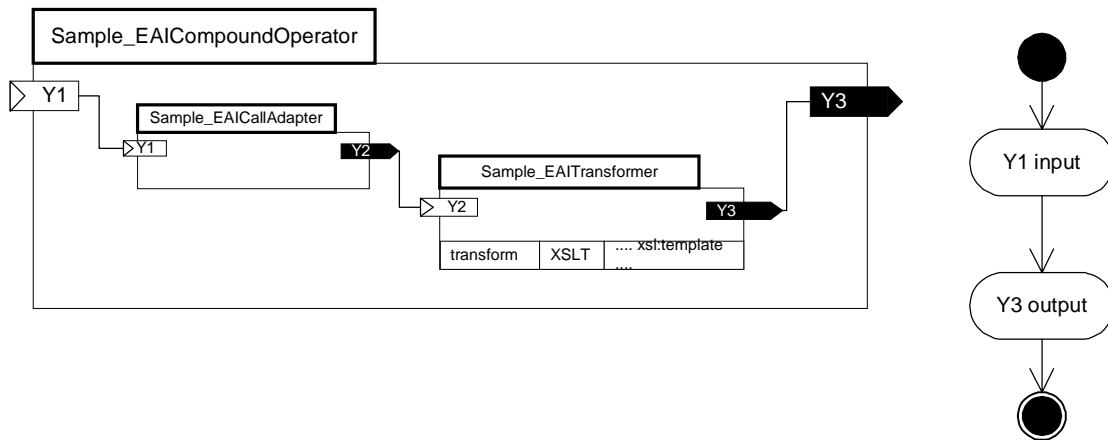

Figure 6-55 CCA notation for sample EAICompoundOperator

6.5.2 Adapters

6.5.2.1 EAISourceAdapter

EAISourceAdapter is a specialized EAIPrimitiveOperator. It corresponds to a CCA ProcessComponent with a single CCA FlowPort with direction = initiates.

The Choreography of the CCA ProcessComponent corresponding to an EAISourceAdapter will show a CCA PortActivity on the FlowPort with direction = initiates.

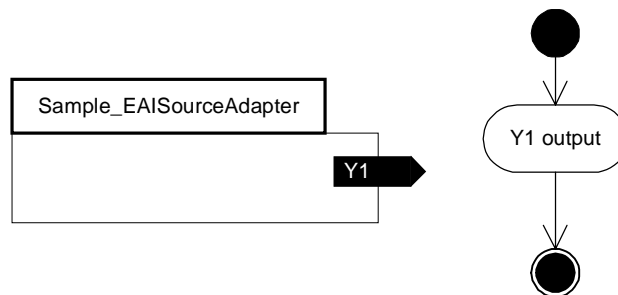

Figure 6-56 CCA notation for a sample EAISourceAdapter

When the EAISourceAdapter is to be utilized in Pull mode, an additional FlowPort will respond to a generic "Get" message that will trigger retrieval from the system and initiate the output.

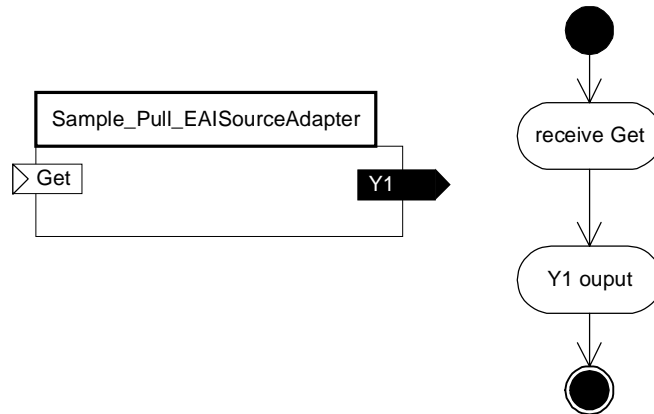

Figure 6-57 CCA notation for a sample Pull mode EAISourceAdapter

6.5.2.2 EAITargetAdapter

EAITargetAdapter is a specialized EAIPrimitiveOperator. It corresponds to a CCA ProcessComponent with a single CCA FlowPort with direction = responds.

The Choreography of the CCA ProcessComponent corresponding to an EAITargetAdapter will show a CCA PortActivity on the FlowPort with direction = responds.

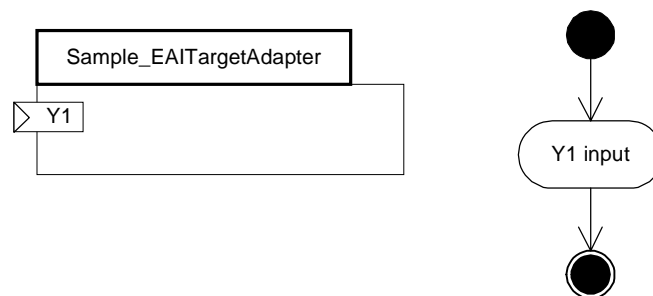

Figure 6-58 CCA notation for a sample EAITargetAdapter

6.5.2.3 *EAIQueuedTargetAdapter*

EAIQueuedTargetAdapter is a specialized *EAIPrimitiveOperator*. It corresponds to a *CCA ProcessComponent* with a single *CCA FlowPort* with direction = responds.

An *EAIQueuedTargetAdapter* offers the same externally observable contract as the *EAITargetAdapter* but with different internal behavior, namely, queued delivery of messages to the system.

Queueing of messages can be directly implemented or delegated into usages of technology-specific message-queue *ProcessComponents* in the internal composition.

6.5.2.4 *EAIAdapter*

EAIAdapter is a specialized *EAIPrimitiveOperator*. It corresponds to a *CCA ProcessComponent* with a *CCA FlowPort* with direction = responds and a *CCA FlowPort* with direction = initiates.

Alternatively, an *EAIAdapter* may correspond to a *CCA ProcessComponent* with a *ProtocolPort*, with subPorts obeying a *Protocol* having a *CCA FlowPort* with direction = responds and a *CCA FlowPort* with direction = initiates. This aggregation in a single *ProtocolPort* of the *FlowPorts* for the call and response messages provides as single connection point for the full call-response, which is similar to the conventional functional invocation in programming languages.

The Choreography of the *CCA ProcessComponent* corresponding to an *EAIAdapter* will show a *CCA PortActivity* on the *FlowPort* with direction = responds, followed by a *CCA PortActivity* on the *FlowPort* with direction = initiates.

An *EAIAdapter* accepts synchronous calls that are not externally observable. It converts these to asynchronous messages that are sent on the output terminal initiating *FlowPort*. It receives a response on the input terminal responding *FlowPort* and passes an equivalent response to the caller. The *EAIAdapter* must implement the logic and mechanisms to wait for the asynchronous response and rebind to the thread of the calling process.

The input and output *CCA FlowPort* may have the same or different *DataElement* type. The *ProcessComponent* will convert the input to the type required by the system. The system will respond with information of a certain type that the *ProcessComponent* must convert into the output *DataElement* type.

The transformation to be performed on the *DataElement* contents can be specified in Properties of the *CCA ProcessComponent* as an expression, script or transformation specification in any of transformation languages available. Alternatively, the transformation can be delegated into usages of other technology-specific transformation *ProcessComponents* in the internal Composition.

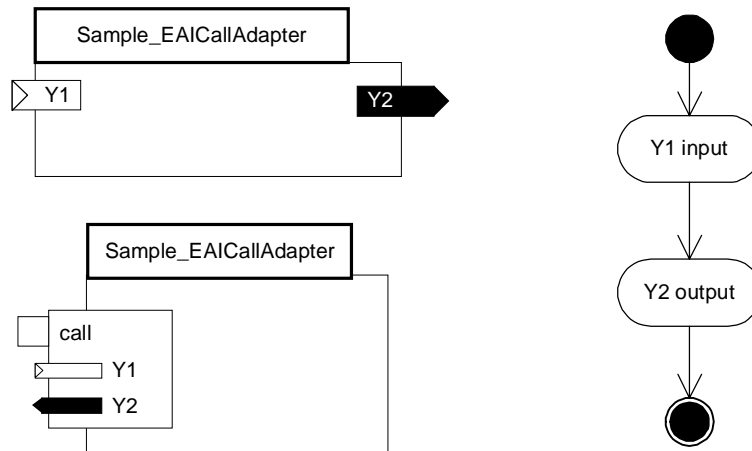

Figure 6-59 CCA notation for sample EAICallAdapter

6.5.2.5 EAIRestReplyAdapter

EAIRestReplyAdapter is a specialized EAIPrimitiveOperator. It corresponds to a CCA ProcessComponent with a CCA FlowPort with direction = responds and a CCA FlowPort with direction = initiates.

Externally, an EAIRestReplyAdapter exposes similar contract and behaves like the EAICallAdapter.

The EAIRestReplyAdapter accepts asynchronous messages. It invokes a system synchronously and returns the response as a message that other applications can process asynchronously. The RequestReplyAdapter presents an asynchronous interface on a synchronous invocation.

6.5.3 CCA and EAI Metamodel Mapping Tables

The following table shows the mapping between EAI and CCA model elements. In many cases the EAI library component is also part of the mapping.

Table 6-1 Model elements mapping table

EAI metamodel element	CCA metamodel element	Library Component (Component Used)
EAIFlow	ProcessComponent	
EAIRouterComposition	ProcessComponent	
EAIPrimitiveOperator	ComponentUsage	EAIPrimitiveOperator
EAICompoundOperator	ComponentUsage	EAICompoundOperator
EAITargetAdapter	ComponentUsage	EAITargetAdapter

Table 6-1 Model elements mapping table

EAI metamodel element	CCA metamodel element	Library Component (Component Used)
EAISourceAdapter	ComponentUsage	EAISourceAdapter
EAIAdapter	ComponentUsage	EAIAdapter
EAIRequestReplyAdapter	ComponentUsage	EAIRequestReplyAdapter
EAIFilter	ComponentUsage	EAIFilter
EAIStream	ComponentUsage	EAIStream
EAIPostDater	ComponentUsage	EAIPostDater
EAITransformer	ComponentUsage	EAITransformer
EAIADBTransformer	ComponentUsage	EAIADBTransformer
EAIAggregator	ComponentUsage	EAIAggregator
EAIRouter	ComponentUsage	EAIRouter
EAIBroadcaster	ComponentUsage	EAIBroadcaster
EAIRouterUpdate	ComponentUsage	EAIRouterUpdate
EAISubscriptionOperator	ComponentUsage	EAISubscriptionOperator
EAISubscriptionFilter	ComponentUsage	EAISubscriptionFilter
EAIPublicationOperator	ComponentUsage	EAIPublicationOperator
EAITimeSetOperator	ComponentUsage	EAITimeSetOperator
EAITimeCheckOperator	ComponentUsage	EAITimeCheckOperator
EAITimer	ComponentUsage	EAITimer
EAISource	Port with direction = responds	
EAIQueuedSource	Port with direction = responds	
EAITopicPublisher		
EAISink	Port with direction = initiates	
EAIQueuedSink	Port with direction = initiates	
EAILink	Connection	
EAIMessageOperation	FlowPort or OperationPort	
EAITerminal	PortConnector	
EAIQueuedInputTerminal	PortConnector	
EAIQueuedOutputTerminal	PortConnector	
EAIPublicationTerminal		
EAISubscriptionRule		
EAITopicRule		
EAIContentRule		
EAIMessageTimerCondition		

Table 6-1 Model elements mapping table

EAI metamodel element	CCA metamodel element	Library Component (Component Used)
EAIMessageContent	CompositeData	
EAIExceptionNotice	CompositeData	
EAIRequestFormat		
EAIQueue		
EAIContent		
EAIRouterUpdateFormat		
EAIAddTargetFormat		
EAISubscriptionFormat		
EAIResource		
EAIMessageAggregation		
EAISubscription		
EAITopic		

Examples of the CCA modeling elements are presented in Chapter 11.

EAI Common Application Metamodel

7.1 Business Requirements and Value

The current trend for new applications is to embrace open Web standards that simplify construction and scalability. As new applications are built, it is crucial to integrate seamlessly with existing systems while introducing new business models and new business processes.

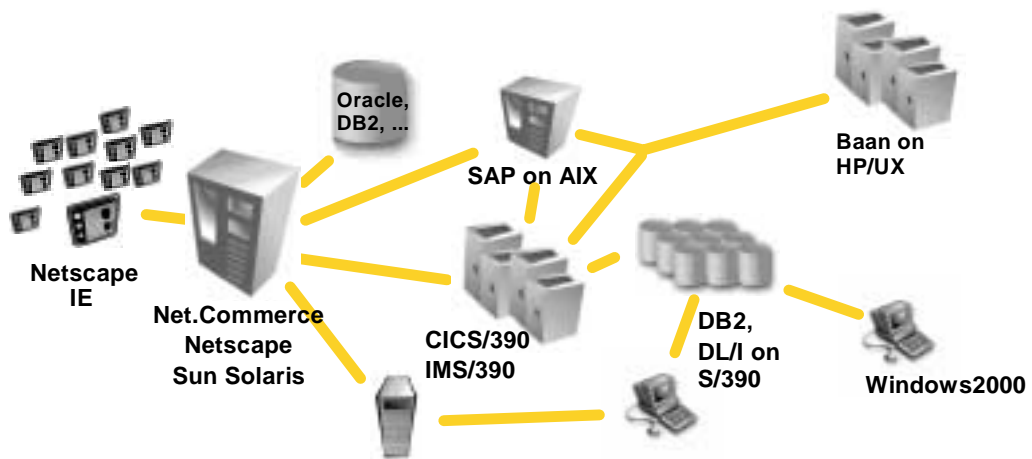

Figure 7-1 Multiple Application and Development Environments

Analysts from the Meta Group estimate that more than 70 % of corporate data lives on the mainframe, much of that on the S/390. Many transactions may be initiated by a Windows/NT or Unix server, but they will be completed on the mainframe under applications, such as CICS, or IMS applications. It is important to leverage and reuse these existing assets, including stored procedures, to provide interoperability with existing applications.

The above figure depicts multiple application components with multiple development teams and environments. Where is the application in this picture? Everywhere! How is the application assembled? With connectors!

Connectors are a central part of the application framework for e-business. The demand is to connect to anything interesting as quickly, and as easily, as possible.

A connector is required to match the interface requirements of the adapter and the legacy application. It is also required to map between the two interfaces. Standardized metamodels for application interfaces allow reuse of information in multiple connector tools. It will not only reduce work to create a connector, but also reduce work needed to develop connector builder tools, thus an incentive to connector suppliers.

7.2 Common Application Metamodel for Applications Interfaces

Business integration technology requires connectors to provide interoperability with existing applications. Connectors support leveraging and reuse of data and business logic held within existing application systems. The job of a connector is to connect from one application system server "interface" to another; it is not meant for an individual application program. Therefore, an application-domain interface metamodel describes signatures for input and output parameters and return types for a given application system domain (e.g. IMS, MQSeries); it is not for a particular IMS or MQSeries application program. The metamodel contains both syntactic and semantic interface metadata.

The following figure showing the EAI metamodel for application interfaces enables integration of application components into event-based messaging model including Flow models.

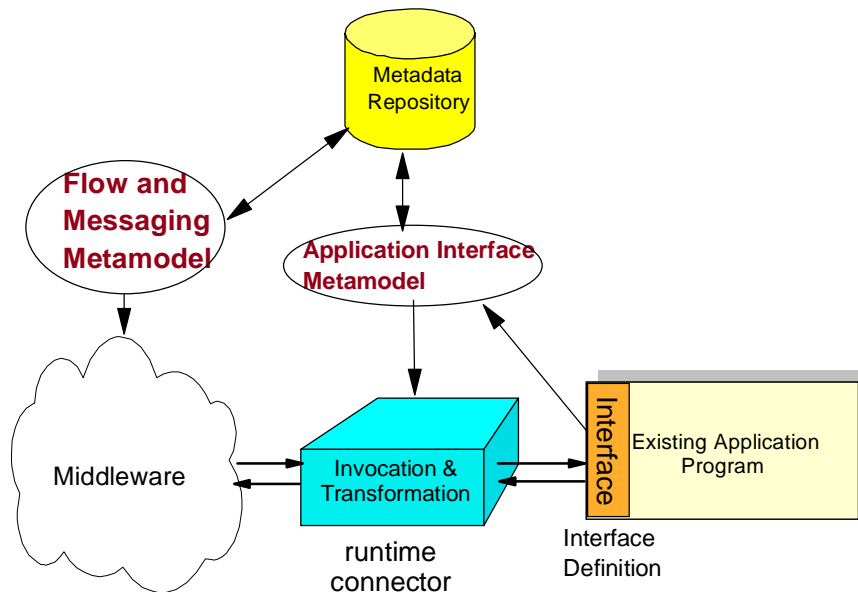

Figure 7-2 Application Interface Metamodel

The flow and messaging middleware invokes applications through the application interfaces. These interfaces are the access points to the applications through which all input and output is connected to the middleware. The interfaces are described in terms of the Application Interface Metamodels. Transformation processing according to the metamodel could take place in source/client applications, target applications, or a gateway.

7.2.1 End-to-End Connector Usage Using EAI Common Application Metamodel

The EAI Common Application Metamodel (CAM) consists of meta-definitions of message signatures, independent of any particular tool or middleware. Different connector builder tools can use this information to ensure the "handshaking" between these application programs, across different tools, languages, and middleware. For example, if you have to invoke an MQSeries application, you would need to build a MQ message using data from a GUI tool and deliver it using the MQ API. Similarly, when you receive a message from the MQSeries application, you would need to get the buffer from MQSeries, parse it and then put it into a GUI tool data structure. These functions can be designed and implemented efficiently by a connector builder tool using EAI CAM as standardized metamodels for application interfaces.

EAI CAM can be populated from many sources, including copy books, to generate HTML forms and JavaServer Page (JSP) for gathering inputs and returning outputs. An example of a connector as depicted in the previous figure is that the flow and message middleware makes a function call to an enterprise application by calling the connector

that then calls the enterprise application API. The connector does language and data type mappings, for example, to translate between XML documents and COBOL input and output data structures based on EAI CAM. Connectors and EAI CAM provide the end-to-end integration between the middleware and the enterprise applications.

Using IMS as an example: Let's say that you must pass an account number to an IMS transaction application program from your desktop to withdraw \$50.00. With EAI CAM and a connector builder tool, you will first generate an input HTML form and an output JSP; and develop a middleware code necessary to support the request. The desktop application fills the request data structure (i.e. an input HTML form) with values and calls the middleware. The middleware service code will take the data from the GUI tool, build an IMS Connect XML-formatted message, and deliver the message to the IMS gateway (i.e. IMS Connect) via TCP/IP. IMS Connect translates between the XML documents and the IMS message data structures in COBOL using the metadata definitions captured in EAI CAM. It then, in turn, sends the IMS message data structures to IMS via Open Transaction Manager Access (OTMA). The IMS COBOL application program runs, and returns the output message back to the middleware service code via IMS Connect. The middleware service code gets the message and populates the output JSP page (i.e. previously generated GUI tool reply data structures) with the reply data. The transaction output data will then be presented to the user.

7.3 *Common Application Metamodel*

CAM is a group of interface metamodels that consist of enterprise application interface metamodels, language metamodels and physical representation metamodels. These include C, C++, Java, COBOL, PL/I, Type Descriptor, TDLang, IMS transaction messages, IMS MFS, and CICS BMS, etc. Note that the Java metamodel is defined in the OMG EDOC (Enterprise Distributed Object Computing) submission.

CAM is highly reusable and independent of any particular tool or middleware. CAM is an incentive to connector suppliers. It reduces work to create and develop connector and/or connector-builder tools. With CAM, tools can now easily access enterprise applications, e.g. IMS and CICS applications; and tools can also access any CAM enabled applications. CAM is used to describe information needed to easily integrate applications developed in common programming models with other systems. CAM can be used for both synchronous and asynchronous invocations.

Because CAM also provides physical representation of data types and storage mapping to support data transformation in an enterprise application integration environment, it enables Web services for enterprise applications.

In a nutshell, CAM is needed for

- connector and/or connector-builder tools (Development time)
- data transformation in an enterprise application integration environment (Execution time)
- data type mapping between mixed languages
- data translations from one language and platform domain into another

- data driven impact analysis for application productivity and quality assurance
- viewing of programming language data declarations by developers

CAM uses MOF and UML class modeling mechanisms. All CAM models are instances of MOF classes at the M2 level.

7.3.1 *Enterprise Application Interface Metamodels*

The Enterprise Application Interface metamodel describes signatures for input and output parameters and return types for application system domains.

The Enterprise Application Interface Metamodels listed as follows are non-normative and can be found in Appendix A.

- IMS Transaction Message
- IMS MFS
- IMS CICS BMS

7.3.2 *Language Metamodels*

The language metamodel, e.g. COBOL metamodel, is used by enterprise application programs to define data structures (semantics) that represent connector interfaces. An association between language metamodels (semantics) and the physical layout metamodel (syntactic) is necessary in order for the marshaller to correctly format the byte string. This association between language metamodels and Type Descriptor metamodel is further detailed in Section 7.3.9, “Physical Representation Model: Convergent Metamodel,” on page 7-22. It is important to connector developers that connector tools show the source language, the target language, and the mapping between the two languages. The CAM language metamodel also includes the declaration text in the model that is not editable (i.e., read-only model). Because the connector/adaptor developer would probably prefer to see the entire COBOL data declaration, including comments and any other documentation that would help him/her understand the business role played by each field in the declaration.

The language metamodel is also to support data driven impact analysis for application productivity and quality assurance. (But, it is not the intention of the CAM to support reproduction of copybooks.)

The language metamodels describing application interface data are listed as follows:

- C
- C++
- COBOL
- PL/I
- Java (Java metamodel is in the OMG EDOC final submission document.)

These language metamodels are found in Chapter 13.

7.3.3 Physical Representation Model: Type Descriptor Metamodel

Type Descriptor metamodel presents a language and platform independent way of describing implementation types, including arrays and structured types. This information is needed for marshaling and for connectors that have to transform data from one language and platform domain into another. Inspections of the type model for different languages can determine the conformance possibilities for the language types. For example, a long type in Java is often identical to a binary type (computational-5) in COBOL, and if so, the types may be inter-converted without side effect. On the other hand, an alphanumeric type in COBOL is fixed in size and if mapped to a Java type, loses this property. When converted back from Java to COBOL, the COBOL truncation rules may not apply, resulting in computation anomalies. In addition, tools that mix languages in a server environment (e.g., Java and COBOL in CICS and IMS) should find it useful as a way to determine how faithfully one language can represent the types of another. Therefore, an instance of the Type Descriptor metamodel describes the physical representation of a specific data type for a particular platform and compiler. The following figures illustrate the classes that constitute the Type Descriptor metamodel and show how the classes relate to each other. Following the diagrams is a brief explanation of what each class represents.

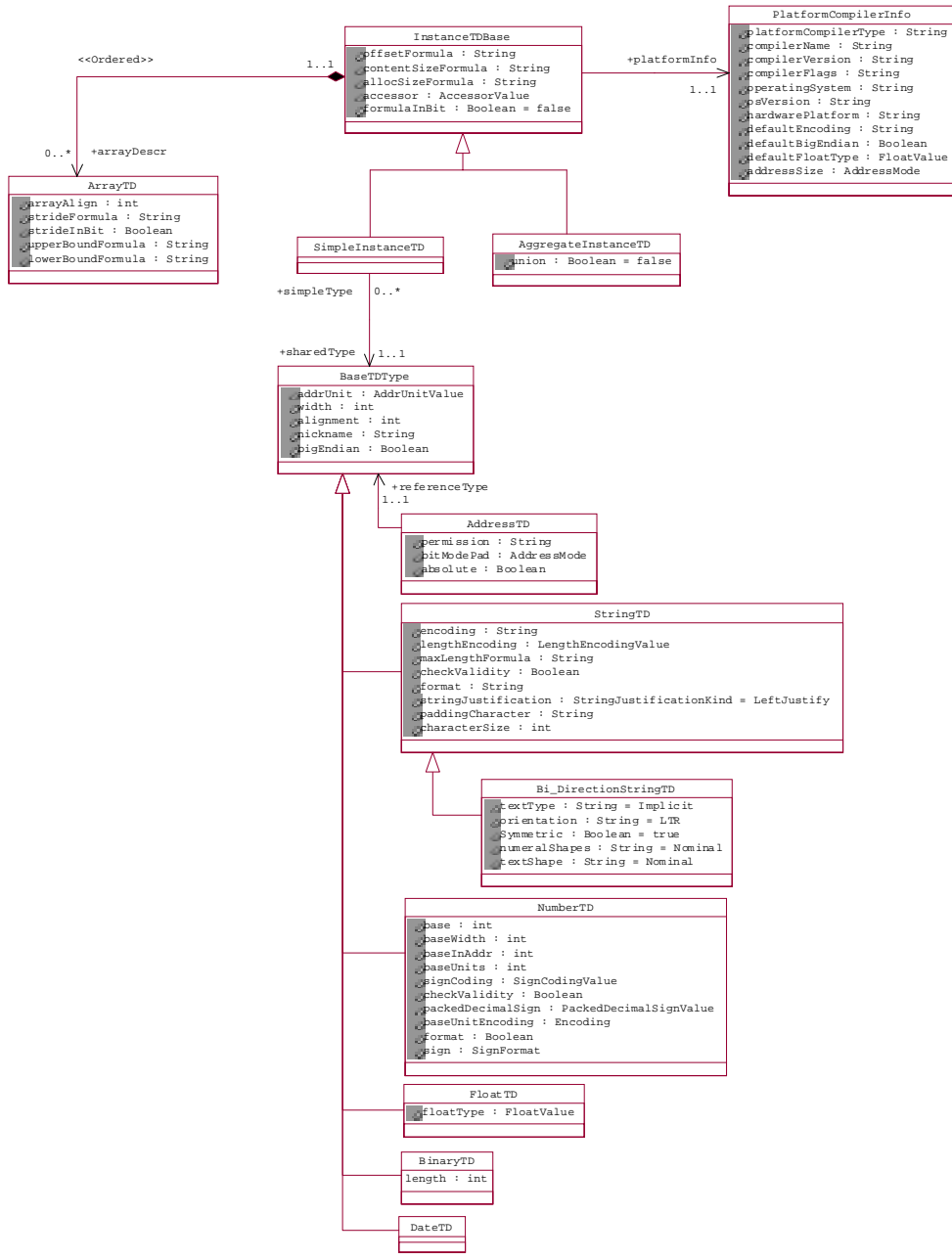

Figure 7-3 Type Descriptor metamodel

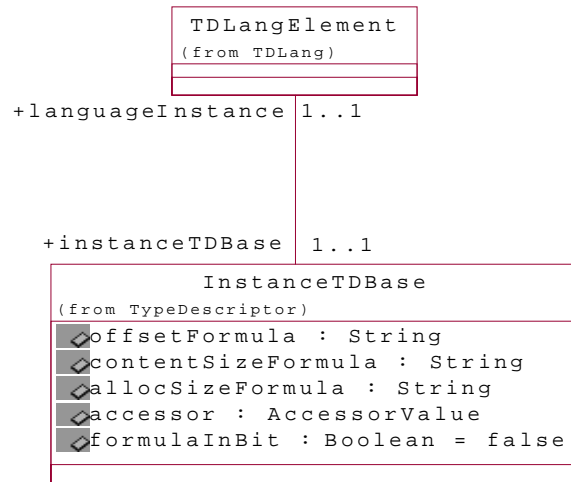

Figure 7-4 TDLang to Type Descriptor

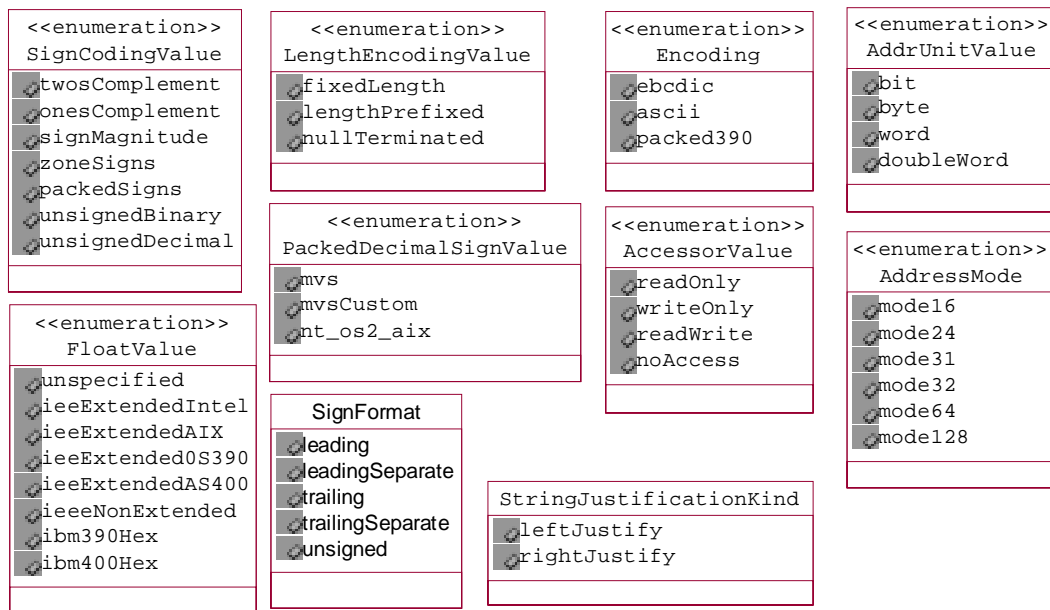

Figure 7-5 Type Descriptor Stereotypes

7.3.4 Type Descriptor Metamodel Descriptions

7.3.4.1 *AddressTD*

AddressTD represent pointers/addresses. Addresses should be considered to be different from *NumberTD* class because some languages on certain machines (e.g., IBM 400) represent addresses with additional information, such as permission type (which is not represented in *NumberTD* class)

7.3.4.2 *ArrayTD*

ArrayTD holds information for array types. Data element instances may be defined as repeating groups or arrays. This is modeled as a one-to-many association between *InstanceTDBase* and the *ArrayTD* model type. One instance of *ArrayTD* is created for each dimension, subscript, or independent index of the data element. Each instance holds information about the bounds and accessing computations. The association order between *ArrayTD* and *InstanceTDBase* is the same as the order for the corresponding association in the language model, and reflects the syntactic ordering of the indices as defined by the programming language.

7.3.4.3 *BaseTDType*

BaseTDType is the abstract parent class of all types in the TD Metamodel. *BaseTDType* holds implementation information common to all data types of the same runtime environment, as specified by *PlatformCompilerInfo*.

7.3.4.4 *Bi-DirectionalStringTD*

Bi-DirectionStringTD is a subclass of *StringTD*. *Bi-DirectionStringTD* represents strings with extended properties and formats such as numeral shapes and right-to-left reading direction.

7.3.4.5 *BinaryTD*

BinaryTD represents a string of binary bits whose format is not to be modified.

7.3.4.6 *DateTD*

DateTD represents date types with its associated format (e.g., mm/dd/yyyy, dd/mm/yyyy)

7.3.4.7 *FloatTD*

FloatTD represents floating point numbers declared by a language element.

7.3.4.8 *InstanceTDBase*

InstanceTDBase is the most basic, fundamental core class of the Type Descriptor Metamodel. Every TD Metamodel instance contains at least one instance of InstanceTDBase. For each instance of a CAM language Element class there is a corresponding instance of InstanceTDBase. InstanceTDBase contains attributes that describe the physical layout of each declared variable and structure element in a program. It is an abstract class realized by either SimpleInstanceTD or AggregateInstanceTD. To find the parent of any instance (if it has one) navigate the association back to the CAM Language Element class (via a language-independent element class, e.g., TDLangElement), follow the association to the language-specific Composed class, then follow the association back to the parent InstanceTDBase.

7.3.4.9 *Number TD*

NumberTD represents all integer and packed decimals.

7.3.4.10 *PlatformCompilerInfo*

PlatformCompilerInfo captures the static compiler and program runtime environment. Since this static information is shared by all instances of InstanceTDBase, this class only needs to be instantiated once.

7.3.4.11 *SimpleInstanceTD and AggregateInstanceTD*

Both SimpleInstanceTD and AggregateInstanceTD are subclasses of InstanceTDBase. InstanceTDBase has two concrete subtypes: SimpleInstanceTD and AggregateInstanceTD. SimpleInstanceTD models data elements without subcomponents, while AggregateInstanceTD models data elements with subcomponents. To find the subcomponents of an AggregateInstanceTD, one must navigate back to the corresponding data element declaration in the CAM language model. There, the association between an aggregate type and its subcomponents may be navigated, leading to a set of subcomponent data elements, each of which has one or more corresponding instances in the Type Descriptor model.

7.3.4.12 *StringTD*

StringTD represents standard left-to-right format character strings. StringTD also supports single characters elements.

7.3.4.13 *Type Descriptor Stereotypes*

- AccessorValue enumerates permission rights for each TDLangElement.
- AddrUnitValue enumerates the unit associated with the value of address attributes in Type Descriptor Metamodel.
- BitModePadValue enumerates the address size. Values in this enumeration are used to calculate padding.

- Encoding enumerates numeric base unit encoding supported by Type Descriptor Metamodel.
- FloatValue enumerates floating types supported by Type Descriptor Metamodel.
- LengthEncodingValue enumerates string length encoding values supported by Type Descriptor Metamodel.
- PackedDecimalSignValue enumerates platforms that support the packed decimal format.
- SignCodingValue enumerates numeric sign encoding values supported by Type Descriptor Metamodel.
- StringJustificationKind enumerates string justification layout values supported by Type Descriptor Metamodel.

7.3.5 Type Descriptor Formulas

In the following discussion, “field” refers to a component of a language data structure described by the Type Descriptor metamodel, while “attribute” denotes part of the model, and has a value representing a “property” of the field. Thus the value of a field means a run-time value in a particular instance of a language data structure, whereas the value of an attribute is part of the description of a field in a language data structure, applies to all instances of the data structure, and is determined when the data structure is modeled.

For most attributes in an instance of the Type Descriptor metamodel, the value of the attribute is known when the instance is built, because the properties of the fields being described, such as size and offset within the data structure, are invariant. But if a field in a data structure is defined using the COBOL OCCURS DEPENDING ON construct or the PL/I Refer construct, then some properties of the field (and properties of other fields that depend on that field’s value) cannot be determined when the model instance is built.

Properties that can be defined using these language constructs are string lengths and array bounds. A property that could indirectly depend on these language constructs is the offset of a field within a structure, if the field follows a variable-size field.

In order to handle these language constructs, properties of a field that could depend on these constructs (and thus the values of the corresponding attributes), are defined with strings that specify a formula that can be evaluated when the model is used.

However, if a property of a field is known when the model instance is built, then the attribute formula simply specifies an integer value. For example, if a string has length 17, then the formula for its length is “17.”

The formulas mentioned above are limited to the following:

- Unsigned integers
- The following arithmetic integer functions

```

neg(x)    := -x           // prefix negate
add(x,y)  := x+y         // infix add
sub(x,y)  := x-y         // infix subtract
mpy(x,y)  := x*y         // infix multiply
div(x,y)  := x/y         // infix divide
max(x,y)  := max(x,y)
min(x,y)  := min(x,y)
mod(x,y)  := x mod y

```

The mod function is defined as $\text{mod}(x,y) = r$ where r is the smallest non-negative integer such that $x-r$ is evenly divisible by y . So $\text{mod}(7,4)$ is 3, but $\text{mod}(-7,4)$ is 1. If y is a power of 2, then $\text{mod}(x,y)$ is equal to the bitwise-and of x and $y-1$.

- The val function

The val function returns the value of a field described by the model. The val function takes one or more arguments, and the first argument refers to the level-1 data structure containing the field, and must be either:

- the name of a level-1 data structure in the language model
- the integer 1, indicating the level-1 parent of the variable-size field. In this case, the variable-size field and the field that specifies its size are in the same data structure, and so have a common level-1 parent.
- The subsequent arguments are integers that specify the ordinal number within its substructure of the (sub)field that should be dereferenced.

By default, COBOL data fields within a structure are not aligned on type-specific boundaries in storage. For example, the “natural” alignment for a four-byte integer is a full-word storage boundary. Such alignment can be specified by using the SYNCHRONIZED clause on the declaration. Otherwise, data fields start immediately after the end of the preceding field in the structure. Since COBOL does not have bit data, fields always start on a whole byte boundary.

For PL/I, the situation is more complicated. Alignment is controlled by the Aligned and Unaligned declaration attributes. By contrast with COBOL, most types of data, notably binary or floating-point numbers, are aligned on their natural boundaries by default.

7.3.6 Type Descriptor Formula Examples

7.3.6.1 COBOL

The examples use the proposed inline comment indicator “*>” from the draft standard. It is not yet legal COBOL usage.

1. Consider the following data description:

*> <u>Field</u>	<u>Offset</u>
01 Used-Car.	*> "0"

```

02 Summary.                *>    "0"
03 Make pic x(36).         *>    "0"
03 Model pic x(44).       *>    "36"
03 VIN pic x(13).         *>    "80"
03 Color pic x(10).       *>    "93"
    88 Red value 'Red'.
    88 White value 'White'.
    88 Blue value 'Blue'.
02 History.                *>    "103"
03 Mileage pic 9(6).      *>    "103"
03 NumClaims binary pic 9. *>    "109"
03 InsCode pic x.         *>    "111"
03 Claims.                *>    "112"
    04 Claim occurs 1 to 9 times
      depending on NumClaims. *> stride(1) = "157"
    05 ClaimNo pic x(14). *>    "112"
    05 ClaimAmt binary pic 9(5). *> "126"
    05 Insurer pic x(39). *>    "130"
    05 Details pic x(100). *>    "169"
02 Price comp pic 9(5)v99. *>
"add(112,mpy(val(1,2,2),157))"

```

The offset of `Model` is straightforward, and is given by the formula “36.” So is that of `Claims`, which is “112.”

But because the array `Claim` can occur a variable number of times, the structure `History` is a variable-size field. Thus the offset of `Price`, which immediately follows `Claims`, requires a more complicated formula, involving the array stride (the distance between successive elements along a specific dimension). In the case when there is only one dimension for `Claim`, the formula for its stride is “157.” Thus the formula offset of `Price` for a single dimension `Claim` is:

```
"add(112,mpy(val(1,2,2),157))"
```

The first argument of the `val` function is 1, meaning that the field containing the value at run-time, `NumClaims`, is in the same level-1 structure, `Used-Car`, as the field, `Price`, whose offset is specified by the formula. The other two arguments are 2 and 2. The first 2 refers to the second immediate subcomponent, `History`, of `Used-Car`. The second 2 means that the field to be dereferenced is the second component of `History`, that is, `NumClaims`.

In the case when `NumClaims` is greater than 1 (i.e., when `Claims` is a multi-dimension array) the offset for each element within `Claims` is 157 more than the offset for the previous dimension. For example, the offset formula for the second instance of `ClaimNo` is $112+157=269$ while the third instance would be $269+157=426$.

If the `OCCURS DEPENDING ON` object were in a separate structure, the third subcomponent of level-1 structure `Car-Data`, say, then the `val` function would be “`val(Car-Data, 3)`.”

2. COBOL structure mapping is top-down, although the direction doesn't make any difference unless the SYNCHRONIZED clause is specified on the data declaration. Specifying SYNCHRONIZED forces alignment of individual fields on their natural boundaries, and thus introduces "gaps" into the structure mapping. Consider the following data structure that is identical to the previous example, except for the SYNCHRONIZED clause:

```

*> Field                                     Offset

01 Used-Car sync.                             *> "0"
  02 Summary.                                  *> "0"
    03 Make pic x(36).                         *> "0"
    03 Model pic x(44).                        *> "36"
    03 VIN pic x(13).                          *> "80"
    03 Color pic x(10).                        *> "93"
      88 Red value 'Red'.
      88 White value 'White'.
      88 Blue value 'Blue'.
    02 History.                                *> "103"
      03 Mileage pic 9(6).                      *> "103"
      03 NumClaims binary pic 9.                *> "110"
      03 InsCode pic x.                         *> "112"
      03 Claims.                               *> "113"
        04 Claim occurs 1 to 9 times
          depending on NumClaims.               *> stride(1) = "160"
            05 ClaimNo pic x(14).               *> "113" plus one
slack byte after each instance of ClaimNo
            05 ClaimAmt binary pic 9(5).        *> "128"
            05 Insurer pic x(39).              *> "132"
            05 Details pic x(100).             *> "171" plus
one slack byte after each instance of Details and one slack
byte after each instance of Claims
          02 Price comp pic 9(5)v99.            *>
"add(add(113,mpy(val(1,2,2),160)),3)"

```

To position the binary fields on their appropriate half-word or full-word storage boundaries, COBOL introduces padding, known as "slack bytes", into the structure. Working top-down, this padding is introduced immediately before the field needing alignment. So there is one byte of padding between Mileage and NumClaims.

For an array, such as Claim, COBOL not only adjusts the padding within an element, but also the alignment of each element of the array. In the example, the first occurrence of Claim starts one byte past a full-word boundary. Because the field ClaimNo is three and a half words long, it ends three bytes past a full-word boundary, so COBOL inserts one byte of padding immediately before the binary full-word integer ClaimAmt. And to align subsequent occurrences, so that they too start one byte past a full-word boundary like the first, and can thus have an identical configuration, COBOL adds two bytes of padding at the end of each occurrence.

Finally, after padding, each occurrence of Claim (starts and) ends one byte past a full-word boundary, so COBOL puts three bytes of padding before the binary field Price. As a result of all these extra bytes, the formula for the offset of Price has changed considerably from the unaligned example, and is now:

```
"add(add(113,mpy(val(1,2,2),160)),3)"
```

There are several differences between the OCCURS DEPENDING ON construct and PL/I's Refer option. Storage for COBOL structures is always allocated at the maximum size, whereas PL/I structures are allocated at the actual size specified by the Refer option. It is legal and usual to change the number of occurrences in a particular instance of a variable-size COBOL array, and this has the effect of changing the location and offset of any fields that follow the array. For PL/I, the value of the Refer object of a particular instance of a structure is intended to be fixed during execution. Thus aligned objects following a variable-size field are always correctly aligned for each instance of the structure, because the amount of padding is computed uniquely for each instance, as determined by the Refer option. By contrast, the amount of padding for any aligned fields following a variable-size COBOL array is computed assuming the maximum array size, and is fixed at compile time. If the array is smaller than its maximum size, then the alignment will typically be incorrect. For instance in this example:

```
1 a sync.
  2 b binary pic 9.
  2 c pic x occurs 1 to 5 times depending on b.
  2 d binary pic 9(9).
```

COBOL inserts one byte between c and d. The alignment of d is therefore correct for only two values of b, the maximum, 5, and 2.

3. As noted above, the formulas describe not only offsets of fields within a structure, but also properties of arrays, such as bounds and strides. COBOL does not have true multi-dimensional arrays, although element references do use multiple subscripts. Instead, COBOL has arrays of arrays, as in the following simple example:

```
1 a. *< offset = "0"
  2 d1 occurs 5 times.      *< offset = "0"
                           *< lbound(1) = "1"
                           *< hbound(1) = "5"
                           *< stride(1) = "168"
  3 d2 occurs 6 times.    *< offset = "0"
                           *< lbound(2) = "1"
                           *< hbound(2) = "6"
                           *< stride(2) = "28"
  4 e1 binary pic 9(9) occurs 7 times.  *< offset =
"0"
                                   *< lbound(3) = "1"
                                   *< hbound(3) = "7"
```

```
*< stride(3) = "4"
```

The program can refer to slices of the array by subscripting the higher-level container fields, for example, `d1(2)` or `d2(3, 4)`, but the normal kind of reference is to the low-level elements using the full sequence of subscripts, for instance, `e1(4, 5, 6)`. To locate element `e1(m, n, o)` using these stride formulas, one would take the address of `a` and add to it $(m-1)*168 + (n-1)*28 + (o-1)*4$. For COBOL, the lower bound of an array subscript is always 1. That is, the first element is always `element(1)`, and vice versa.

Needless to say, any dimension of the array can have the `OCCURS DEPENDING ON` clause, and the array can be followed by other fields that complicates the formulas a lot. Consider the example:

```
1 a.
  2 x1 binary pic 9.           *< offset = "0"
  2 x2 binary pic 9.           *< offset = "2"
  2 x3 binary pic 9.           *< offset = "4"
  2 d1 occurs 1 to 5 times     *< offset = "6"
    depending on x1.          *< lbound(1) = "1"
                              *< hbound(1) = "val(1,1)"
                              *< stride(1) =
"mpy(val(1,2),mpy(val(1,3),4))"
  3 d2 occurs 1 to 6 times     *< offset = "6"
    depending on x2.          *< lbound(2) = "1"
                              *< hbound(2) = "val(1,2)"
                              *< stride(2) = "mpy(val(1,3),4)"
  4 e1 binary pic 9(9)         *< offset = "6"
    occurs 1 to 7 times       *< lbound(3) = "1"
    depending on x3.          *< hbound(3) = "val(1,3)"
                              *< stride(3) = "4"
  2 b binary pic 9(5).         *< offset = "see below!"
```

Computing the address of a particular element still involves the stride formulas, but these are no longer simple integers. The address of element `e1(m, n, o)` in the above example is given by taking the address of `a` and adding to it:

$$(m-1)*stride(1) + (n-1)*stride(2) + (o-1)*stride(3), \text{ i.e.,}$$

$$(m-1)*4*val(1,3)*val(1,2) + (n-1)*4*val(1,3) + (o-1)*4.$$

Similarly, these stride formulas are used in the formula for the offset of `b`:

```
"add(6,mpy(val(1,1),mpy(val(1,2),mpy(4,val(1,3))))"
```

7.3.6.2 *PL/I*

1. Given the following structure

```

dcl /* offset
    1 c unaligned          /* "0" */
      ,2 c1                /* "0" */
        ,3 c2 fixed bin(31) /* "0" */
        ,3 c3 fixed bin(31) /* "4" */
        ,2 c4              /* "8" */
          ,3 c5 fixed bin(31) /* "0" */
          ,3 c6 fixed bin(31) /* "4" */
          ,3 c7 fixed bin(31) /* "8" */
          ,2 c8 fixed bin(31) /* "20" */
          ,2 c9 char( * refer(c7) ) /* "24" */
          ,2 c10 char(6) /* "add(24,val(1,2,3))" */
          ,2 c11 char(4) /*
"add(add(24,val(1,2,3)),6)" */
;

```

The offset of c3 would be given by the simple formula “4”, but the offset of c10 would be given by the formula:

```
"add(24,val(1,2,3))"
```

The first argument in the above val function is 1 that indicates the current structure, c. The subsequent arguments are 2 and 3, indicating that the third element, c7, of the second level-2 field, c4, is the field to be dereferenced.

The offset of c11 is equal to the offset of c10 plus the length of c10 and would be given by the following formula:

```
"add(add(24,val(1,2,3)),6)"
```

2. PL/I structure mapping is not top-down, and this can be illustrated by examining the mapping of the following structure:

```

dcl /* offset
    1 a based,            /* "0" */
      2 b,                /* "0" */
        3 b1 fixed bin(15), /* "0" */
        3 b2 fixed bin(15), /* "2" */
        3 b3 fixed bin(31), /* "4" */
        2 c,              /*
"add(8,mod(neg(val(1,1,1)),4))" */
        3 c1 char( n refer(b1)), /* "0" */
        3 c2 fixed bin(31); /* "val(1,1,1)" */

```

The value of b1 is given by val(1,1,1), and in order to put c2 on a 4-byte boundary, PL/I puts any needed padding before c (yes, not between c1 and c2), and hence the offset of c would be given by the following formula:

```
"add(8,mod(neg(val(1,1,1)),4))"
```

So if b1 contains the value 3, then this formula becomes $\text{add}(8, \text{mod}(\text{neg}(3), 4))$, which evaluates to 9. I.e., there is one byte of padding between the structure b and the structure c.

3. The model also uses these formulas to specify the bounds and strides in an array, where the stride is defined as the distance between two successive elements in an array.

For example, in the following structure, the second dimension of a.e has a stride specified by the formula “4”, and the first dimension by the formula “20”:

```

dcl
  1 a,                                /* offset = "0" */
    2 b(4) fixed bin(31),             /* offset = "0" */
                                        /* lbound(1) = "1" */
                                        /* hbound(1) = "4" */
                                        /* stride(1) = "4" */
    2 c(4) fixed bin(31),             /* offset = "16" */
                                        /* lbound(1) = "1" */
                                        /* hbound(1) = "4" */
                                        /* stride(1) = "4" */
    2 d(4) char(7) varying,           /* offset = "32" */
                                        /* lbound(1) = "1" */
                                        /* hbound(1) = "4" */
                                        /* stride(1) = "9" */
    2 e(4,5) fixed bin(31);           /* offset = "68" */
                                        /* lbound(1) = "1" */
                                        /* hbound(1) = "4" */
                                        /* stride(1) = "20" */
                                        /* lbound(2) = "1" */
                                        /* hbound(2) = "5" */
                                        /* stride(1) = "4" */

```

This means that to locate the element a.e(m,n), one would take the address of a.e and add to it $(m-1)*20 + (n-1)*4$.

If the example were changed slightly to:

```

dcl
  1 a(4),                                /* offset = "0" */
                                        /* lbound(1) = "1" */
                                        /* hbound(1) = "4" */
                                        /* stride(1) = "40" */
    2 b fixed bin(31),                 /* offset = "0" */
    2 c fixed bin(31),                 /* offset = "4" */
    2 d char(7) varying,               /* offset = "8" */
    2 e(5) fixed bin(31);              /* offset = "20" */
                                        /* lbound(1) = "1" */

```

```

/* hbound(1) = "5"      */
/* stride(1) = "4"      */

```

then there is padding between d and e, but the user of the type descriptor can be blissfully unaware and simply use the stride and offset formulas to locate any given array element.

The stride for a is “40”, the stride for e is “4”, and the offset for e is “20.” This means that to locate the element a(m).e(n), one would take the address of a and add to it $(m-1)*40 + 20 + (n-1)*4$.

Finally, if the example were changed again to:

```

dcl
  1 a(4),                /* offset = "0"      */
                        /* lbound(1) = "1"    */
                        /* hbound(1) = "4"    */
                        /* stride(1) = "40"   */
  2 b fixed bin(31),    /* offset = "0"      */
  2 c(8) bit(4),        /* offset = "4"      */
                        /* lbound(1) = "1"    */
                        /* hbound(1) = "8"    */
                        /* stride(1) = "4"    */
  2 d char(7) varying, /* offset = "8"      */
  2 e(5) fixed bin(31); /* offset = "20"     */
                        /* lbound(1) = "1"    */
                        /* hbound(1) = "5"    */
                        /* stride(1) = "4"    */

```

then the computations for a.e are the same as above, but the computations for a.c become interesting.

The stride for a is still “40”, the stride for c is “4” (but this “4” is a count of bits, not bytes), and the byte offset for c is “4.” To locate the element a(m).c(n), one needs both a byte address and a bit offset. For the byte address, one would take the address of a and add to it $(m-1)*40 + 4 + ((n-1)*4)/8$. The bit offset of a(m).c(n) would be given by $\text{mod}((n-1)*4,8)$.

7.3.7 Physical Representation Model: TDLang Metamodel

The TDLang metamodel serves as base classes to CAM language metamodels by providing a layer of abstraction between the Type Descriptor metamodel and any CAM language metamodel, including higher level languages. All TDLang classes are abstract and common to all the CAM language metamodels. All associations between TDLang classes are marked as "volatile," "transient," or "derived" to reflect that the association is derived from the language metamodel. The TDLang model does not provide any function on its own, but it is the type target for the association from the Type Descriptor metamodel to the language metamodels.

With the TDLang base classes, the Type Descriptor metamodel can be used as a recipe for runtime data transformation (or marshaling) with the language-specific metamodel for overall data structures and field names, without duplicating the aggregation (parent-child) associations present in the language model.

The TDLang model eliminates the need to have unique associations from each language model to the Type Descriptor model (e.g., cobolToTD and cToTD). All language models can access InstanceTDBase by calling the instanceTDBase association through the parent TDLangElement class.

The following figure illustrates the TDLang Metamodel. TDLang connects language models to the Type Descriptor Model. The TDLang metamodel acts as a generic placeholder for a variety of language models to inherit from. Following the diagram is a brief explanation of what each class represents.

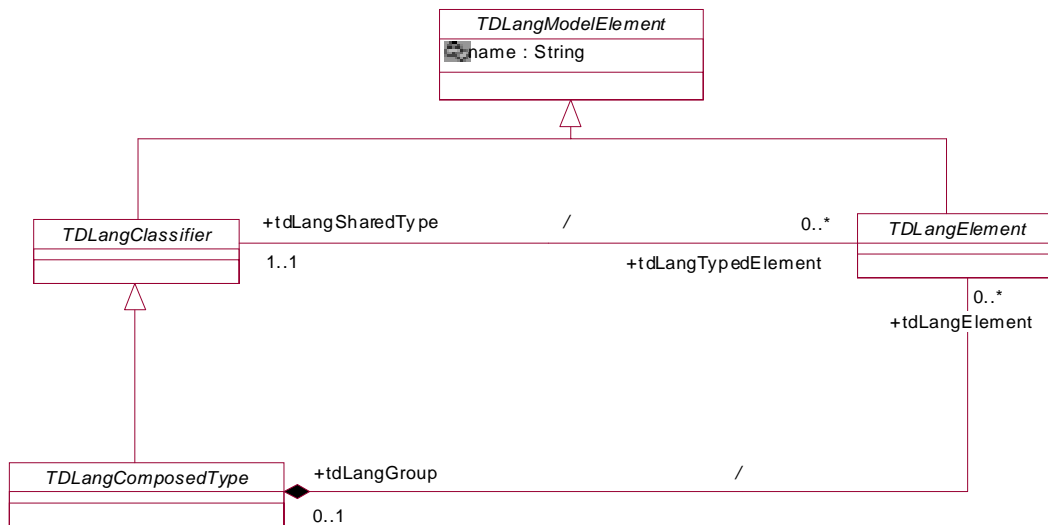

Figure 7-6 TDLang Metamodel

7.3.8 TDLang Metamodel Descriptions

7.3.8.1 TDLangClassifier

TDLangClassifier is the parent class of all CAM language Classifier classes and *TDLangComposedType*. *TDLangClassifier* represents all data types of a CAM language metamodel. Since *TDLangClassifier* is abstract, it is implemented by language specific classifier classes. Sample subclasses of *TDLangClassifier* include String, integer, character, float, and addressable pointers for each language model. Subclasses of *TDLangClassifier* provide the type information declared by a *TDLangElement*.

7.3.8.2 *tdLangTypedElement : TDLangElement*

Used by an element within a ComposedType to navigate back to the parent ComposedType.

7.3.8.3 *TDLangComposedType*

TDLangComposedType represents the type of data with subcomponents. TDLangComposedType is the parent class of all CAM language ComposedTypes. Since TDLangComposedType is abstract, it is implemented by language specific composed classes. Sample subclasses of TDLangComposedType are COBOL 01-level data declarations with nested elements, C structs and unions, and PL/I structures, unions, or elementary variables and arrays.

tdLangElement : TDLangElement

Used by TDLangComposedType to get a list a TDLangElements contained within the composed type.

7.3.8.4 *TDLangElement*

TDLangElement is the most basic, fundamental core class of the TDLang Metamodel. TDLangElement is the parent class of all CAM language element classes. TDLangElement represents typed unit elements declared in a copybook or source code, that is typed data elements without a subcomponent. Since TDLangElement is abstract, it is implemented by language specific element classes. Sample subclasses of TDLangElement are COBOLElement, CTypedElement, and PLIElement.

tdLangGroup: TDLangComposedType

Used by TDLangElement to determine the TDLangComposedType it belongs to.

tdLangSharedType : TDLangClassifier

Used by TDLangElement to determine the type associated to the element.

7.3.8.5 *TDLangModelElement*

TDLangModelElement is the parent class of all TDLang classes. TDLangModelElement represents a combination of an element and its declared data type. Since elements and user-defined types may have associated names, TDLangModelElement has a name attribute that can be separately instantiated by TDLangElement and TDLangClassifier.

7.3.9 Physical Representation Model: Convergent Metamodel

The Type Descriptor metamodel is a language-independent model used to convert a datatype into its expected language-specific type. This is accomplished by associating the base class, InstanceTDBase, to TDLangElement. As the parent class of all language model element classes, TDLangElement allows Type Descriptor to access the information regarding all language-specific data types for marshaling. Type Descriptor's association to the language elements via TDLangElement also provides the aggregate associations captured in the language models (i.e., the ComposedTypes associations for parent-child relationships). This ability to navigate up to parent or sibling elements is required to determine the value of various formula-based attributes in the Type Descriptor model. For example, in order for a child element C to determine its offset formula value, it will need to navigate up to element B to find B's offset value and allocation size. The result of the adding element B's offset value and allocation size is element C's offset value.

Caching and navigation are two approaches to determining the parent value, but the navigation approach is superior to the cache approach in two respects. First, contents in the cache may become invalid as subscript values change from one child element to the next during runtime, resulting in inaccurate cache data. Second, to fix this problem the marshaller will need to recalculate the values of each element at runtime, resulting in a decrease in performance. In the case when we apply navigation from the Type Descriptor model to the language models, we are able to quickly go from the child to the parent element to determine the formula information on a real-time basis. The navigation approach provides accurate values quickly without the need to perform recalculations.

The next diagram shows how language models associate to the Type Descriptor model via the TDLang model. Following the diagram is a brief explanation of what each class represents.

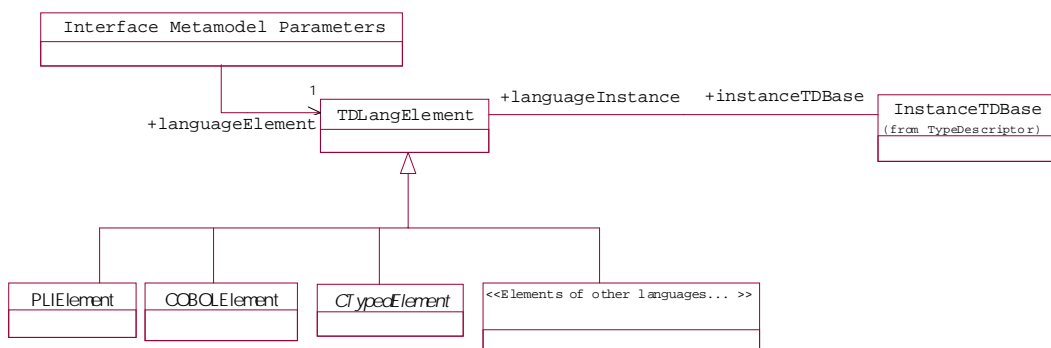

Figure 7-7 Convergent Metamodel

7.3.10 Convergent Metamodel Descriptions

7.3.10.1 Interface Metamodel Parameters

Interface Metamodel Parameters represent a variety of input and output parameter classes which map to underlying language elements. Information on the language element's physical representation is captured by the Type Descriptor metamodel. Each instance of `TDLangElement` maps its corresponding physical representation in `InstanceTDBase`. `TDLangElement` navigates to `InstanceTDBase` via the `instanceTDBase` association. Examples of Enterprise Application Metamodel Parameters include `ApplicationData` (from IMS Transaction Message Metamodel), `MFSMessageField` (from IMS MFS Metamodel), and `FCMParameter` (from FCM Metamodel).

7.3.10.2 TDLangElement and Language Elements

As stated in Section 7.3.8.4, “`TDLangElement`,” on page 7-21, `TDLangElement` is the parent class of all CAM language Element classes. Figure 7-7 on page 7-22 shows how any CAM language element can be modeled to support any given Interface Metamodel Parameter.

7.3.10.3 InstanceTDBase

As stated in Section 7.3.4.8, “`InstanceTDBase`,” on page 7-10, `InstanceTDBase` is used to represent the physical layout of each language element.

7.3.11 Sample Serialization of Convergent Metamodel

An example of how a marshaller might traverse the Type Descriptor-TDLang-Language model is as follows:

Given the following COBOL Data Declaration:

```

01      NAME .
        02      FIRST      PIC X(10) .
        02      LAST       PIC X(10) .

```

The following COBOL and Type Descriptor XMI instances would be serialized:

```

<COBOLElement ... level="01" name="NAME" ....>

  <AggregateInstanceTDBase ... offsetFormula="0" content-
  tSizeFormula="20" allocSizeFormula="20" accessor="readWrite"
  formulaInBit="false" defaultFloatType="ibm390Hex"/>

  <COBOLComposedType ... typedef="false" ..../>

    <COBOLElement ... level="02" name="FIRST" ..../>

      <SimpleInstanceTD ... offsetFormula="0" contentSize-
      Formula="10" allocSizeFormula="10" accessor="readWrite" for-
      mulaInBit="false" defaultFloatType="ibm390Hex"/>

      <COBOLElement ... level="02" name="LAST" ..../>

        <SimpleInstanceTD ... offsetFormula="10" contentSize-
        Formula="10" allocSizeFormula="10" accessor="readWrite" for-
        mulaInBit="false" defaultFloatType="ibm390Hex"/>

      </COBOLComposedType>

    </COBOLElement>

```

Of particular interest is how the offsetFormula is determined. In order to determine the offsetFormula value of element LAST, the model needs to be able to navigate upward from LAST's SimpleInstanceTD to FIRST's SimpleInstanceTD to determine the offsetFormula and allocSizeFormula attributes of FIRST. Formula-based values can either be static (serialized during import time) or dynamic (serialized during runtime). It is this capability to navigate back-and-forth from language models to Type Descriptor that allows us to determine how to marshal each language element.

Formula-based attributes in the Type Descriptor model are typed as String in order to support both calculation and numeric values. Runtime determined values such as COBOL's Occurs-Depending-On clause will have calculation formulas as its value (e.g., "20+10x") while static values will use numeric values (e.g., allocSizeFormula of FIRST is "10"). Calculation formulas will be evaluated by a "Formula Evaluator", which takes the formula String as input and returns the calculated numeric value when runtime information is available (e.g., once the 'x' value of formula "20+10x" is determined we can return a numeric value). In the case of an numeric value (evaluated integer), simply pass the attribute value into a "Formula Evaluator" program and the integer representation of the string will be returned. The formulas in the Type Descriptor model should be generic for all languages, therefore, the "Formula Evaluator" will cover all languages (COBOL, C, C++, PL/I, etc.).

Part 3 - Profile Definition

Contents

This section contains the following chapters.

Section	Page
8. Collaboration Modeling	8-1
9. Activity Modeling	9-1

The profile presented here focuses on two main modeling approaches, based on collaborations and based on activities. These are described in Chapters 8 and 9, respectively.

The collaboration-modeling approach is based on a modeling framework of classes that provide detailed definitions of the semantics of the collaboration. It is thus useful for providing the detailed specification of message flows in the design of integration subsystems.

The activity-modeling approach is based on the use of activity graphs. This approach is particularly useful for showing the overall control and data flow required for integration, typically at a higher level than in collaboration modeling.

Casting the metamodel as a UML profile allows EAI architecture models to be notated using standard UML notation. This means that most UML tools (specifically ones which support the extension mechanisms of UML, such as stereotypes and tagged values) can be used to define EAI architecture models.

Standard practice for defining UML profiles has been adopted. A mapping of metamodel classes to their base UML classes, with accompanying stereotypes, tagged values and constraints is summarised for each approach. An implementation of this mapping can be used, for example, to generate metadata conforming to the EAI

metamodel from XMI generated from models notated using the UML profile. Specialized EAI tools will more likely use the metamodel than the UML profile as a basis for storing and manipulating models.

The art of defining a UML profile is to provide the best fit possible with UML, so that the notation is natural for a modeler in the relevant domain (EAI in this case), and fits with one's general intuitions about the meaning of the elements of UML that are used in the profile. The profile described here has been designed with these principles in mind.

8.1 Overview

8.1.1 General Approach

The collaboration profile makes use of UML class and collaboration diagrams to notate EAI models. The main parts of the profile are:

- Notation for terminals
- Notation for operators
- Notation for resources
- Notation for message formats

Operators are notated by class diagrams, which declare the input and output terminals of the operator and the message formats of those terminals. The class diagram can also be annotated with the definition of the operations performed when manipulating incoming messages to generate outgoing messages.

For compound operators, class diagrams also specify the component operators of the compound, which may, themselves, be compound operators. Collaboration diagrams are used to show how its components are connected together.

Different kinds of terminals are defined by appropriate stereotypes on UML Class. Specific, named terminals are identified with operators via associations.

Different kinds of operator are identified by appropriate stereotypes on UML Class.

Some operators make use of resources. Resources are notated by classes, with stereotypes used to capture the different kinds of format.

Message formats are notated by classes, with stereotypes used to capture the different kinds of format.

8.1.2 Use of UML operations

There are places where UML operations have been used with specific names to 'carry' certain pieces of metadata within a model defined by the profile. For example, when one defines a terminal, it is necessary to define an operation called handle whose return type determines the format of message content that the terminal can handle; when one defines a filter, it is necessary to define a boolean operation allow which determines, for a message supplied as argument, the conditions under which a message can pass through the filter. This approach to encoding this information was taken, because it accords with one's intuitions about the meaning of UML and of UML operations in particular. For example, one is able to explain what a filter does by referring to its allow operation - only incoming messages for which the allow operation evaluates to true get passed on.

It should be stressed that the operations themselves imply nothing about the scheme used to implement models, though clearly the information they hold will need to be carried through in some way. Indeed, most implementations are likely to work from the metamodel direct (as this issue does not arise there) and the profile just used as a means of defining models using UML notation, which can then get converted to instances of the metamodel for subsequent processing.

There are many ways to show the definition of UML operations, which will depend on specific organizational practices and/or support provided by UML CASE tools. One device that is commonly used is to attach notes to the class containing the operation. This device has been used in all examples used to illustrate the definition of this profile.

8.1.3 Concrete Notation

Only raw stereotypes have been defined in this profile. The user may replace these with concrete icons at his or her discretion.

8.1.4 Chapter structure

The remainder of this chapter provides a detailed description of each of the four parts of the profile. Each part is described stereotype by stereotype, using generic examples for illustration. The constraints that apply in the context of a particular stereotype are also defined. The detailed descriptions are followed by a section describing the mapping of the EAI metamodel to the elements of the profile. This section also provides a summary of the stereotypes used in the profile, and follows the format laid down by UML 1.4.

8.2 Terminals

The terminals of an operator are shown by associations to classes with stereotypes <<input>> (for input terminals) and <<output>> (for output terminals), from classes with operator stereotypes (see sections below). A prototypical example showing the definition of terminals for a primitive operator is given in Figure 8-1. This shows a primitive operator with two input and two output terminals. The output terminals are of

the same kind, but the input terminals are not (one is known to be a queued terminal, even though they both handle the same kind of message format). The names of the terminals are, in this case, label1 and label2.

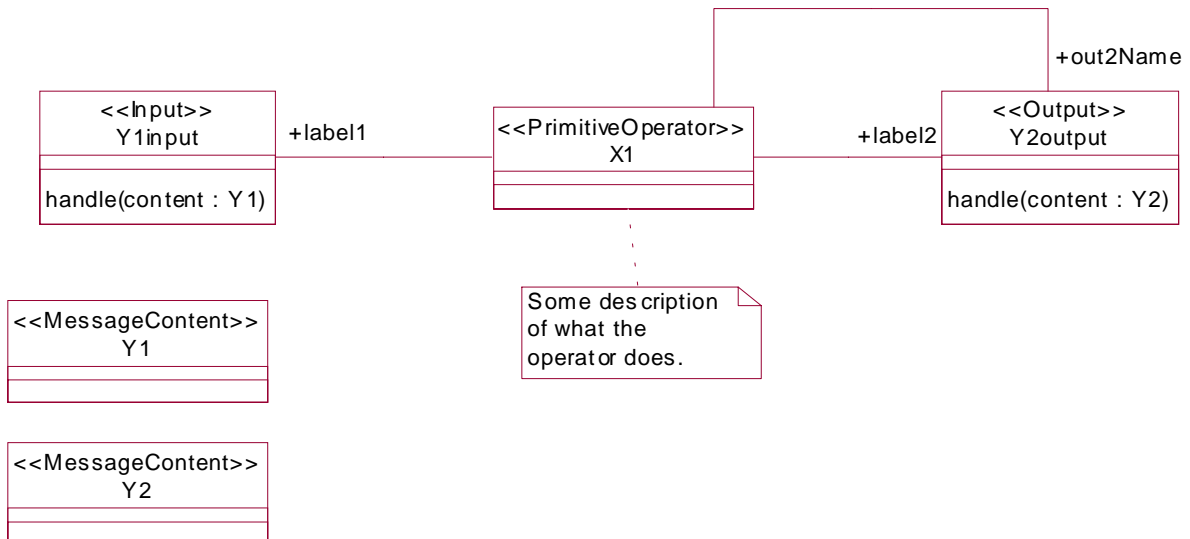

Figure 8-1 Class diagram for prototypical primitive operator with terminals

An input terminal is responsible for conveying incoming messages to the operator, while an output terminal is responsible for conveying outgoing messages away from the operator. The names of the terminals with respect to the operator are specified as labels on the appropriate association end. In general, operators may have one or more input and one or more output terminals. The number and names of the input and output terminals may be constrained for specialist primitive and compound operators.

Terminals can handle messages with a specified content format. This is indicated by declaring an operation handle on the class defining terminal kinds (i.e., classes with stereotypes <<input>> and <<output>>) which takes one argument of the specified format. Formats are specified by classes with a stereotype <<LangElement>> or one of its substereotypes, or stereotype <<MessageContent>> or one of its substereotypes. For most operators (adapters are the exceptions), the stereotype will usually be <<MessageContent>> corresponding to the generic format for message content.

It is not the role of this specification to say how a terminal handles its messages. However, the stereotypes <<QInput>> and <<QOutput>> may be used to indicate that handling is performed using a queue. Unless stated otherwise (e.g., as a constraint), it is assumed that terminals defined for any kind of operator may be plain or queued.

Finally, dynamic connection of terminals is supported. That is, it is possible to send some operators (for example routers) a message containing a terminal identifier, so that the operator can add or remove that terminal from the list of targets of one or more of its output terminals. The targets of an output terminal are the terminals connected to it.

Constraints

There should only be one input and output class per handle format/stereotype pairing, and the name of this class will be a concatenation of the format name and the stereotype name.

The type of the content parameter of the handle operation must have a stereotype of <<LangElement>> or one of its sub-stereotypes, or of <<MessageContent>> or one of its substereotypes.

8.3 Operators

8.3.1 Primitive Operator

Figure 8-1 on page 8-3 also shows a prototypical example of the definition of a primitive operator.

Primitive operators are useful for notating operators which have no internal structure (or whose internal structure is of no interest) such as system applications. A generic primitive operator is shown as a class with a stereotype <<PrimitiveOperator>>. The class may have an associated note (corresponding to EAIAnnotation in the metamodel) for recording a description of what the operator does.

Constraints

The type of content of the terminals of a generic primitive operator must have a stereotype <<MessageContent>> or one of its substereotypes.

8.3.2 Transformers and Database Transformers

Figure 8-2 shows the general format of the notation used to define a transformer, which is represented by a class with stereotype <<Transformer>>. A transformer uses the transform operation to transform the content of the input message and then sends the transformed message via the single output terminal of the transformer.

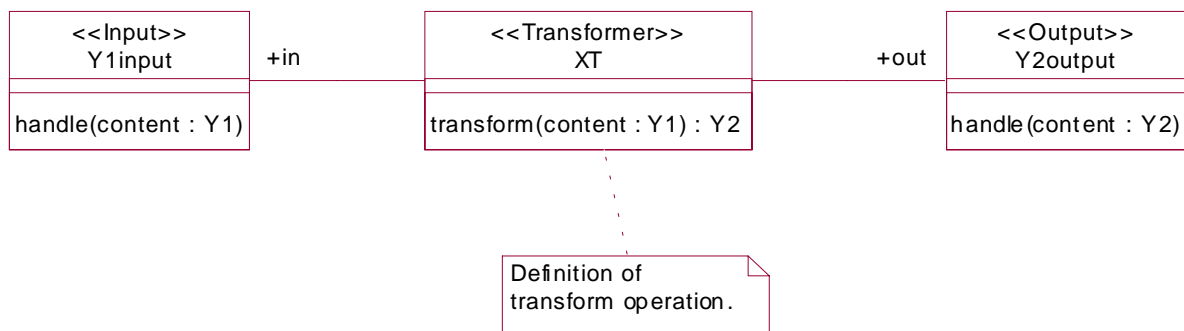

Figure 8-2 Class diagram for prototypical transformer

A database transformer is just like a transformer, except that it accesses a database in order to perform the transform operation. In this case, the stereotype <<DBTransformer>> is used, and this requires a database resource to be declared, as in Figure 8-3.

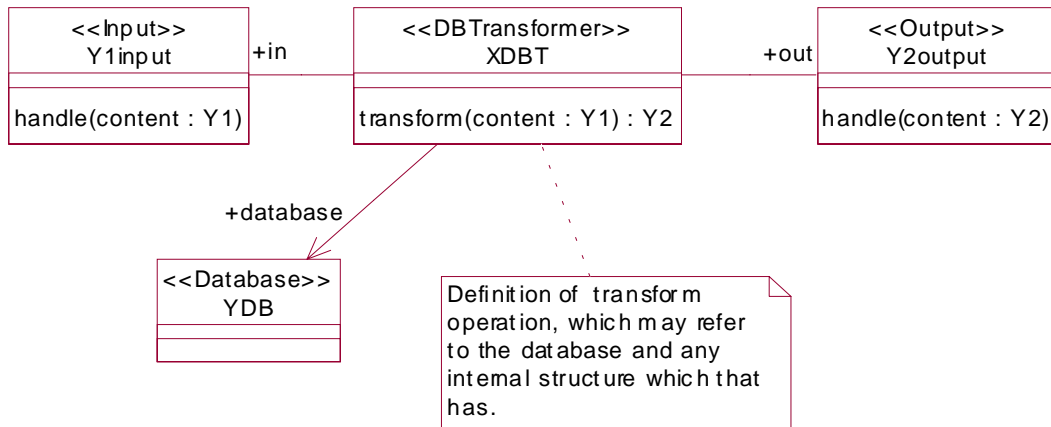

Figure 8-3 Class diagram for prototypical database transformers

Additionally, the definition of transform may make reference to this attribute.

Constraints

The input terminal must be labelled in and the output terminal out.

The content format of in and out must match the format of the parameter and result, respectively, of the transform operation.

The type of content of the terminals of a transformer must have a stereotype <<MessageContent>> or one of its substereotypes.

For database transformers, there must be a directed association to a database resource (i.e., a class with stereotype <<Database>>). This should be labeled database.

8.3.3 Filters

Figure 8-4 shows the general format of the notation used to define a filter.

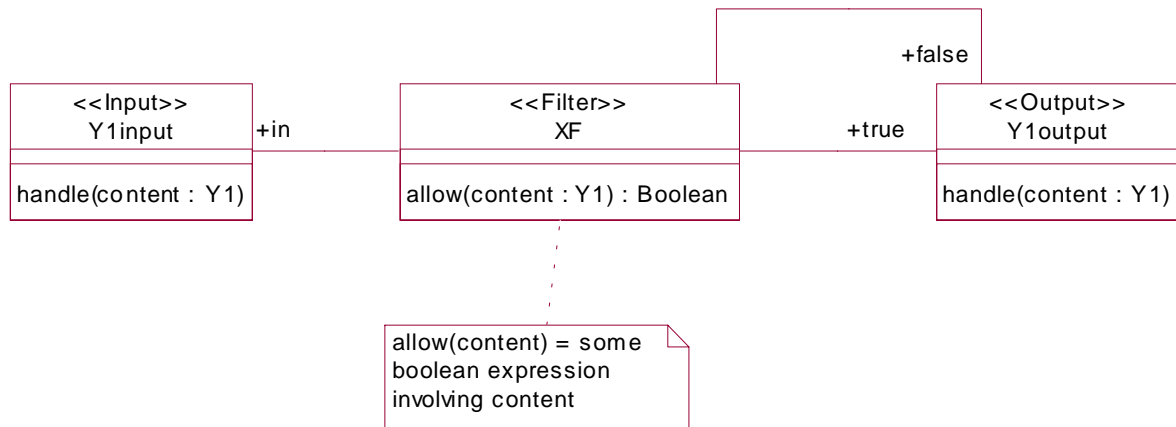

Figure 8-4 Class diagram for prototypical filter

A filter does not modify the content of the messages it receives. However, a filter only passes on those messages whose content meets specific criteria. When a filter is triggered, it uses the allow operation to test if the content of the input message meets the criteria. If so, the content is sent to the true output terminal, otherwise it is sent to the false terminal.

Constraints

The input terminal must be labelled in, and the output terminals true and false.

The content format of all the terminals must match that of the parameter of the allow operation. This type must have a stereotype <<MessageContent>> or one of its substereotypes.

8.3.4 Streams

For operators described so far it is assumed that messages are always received in the order that they are sent and that there is basically no delay in their transmission. In reality, there are some cases where a stream of messages may be received in a different order than that in which they are sent and they may be received at a different rate than that at which they are sent. A stream operator is used to model this. Figure 8-5 shows the general format of the notation used to define a stream operator.

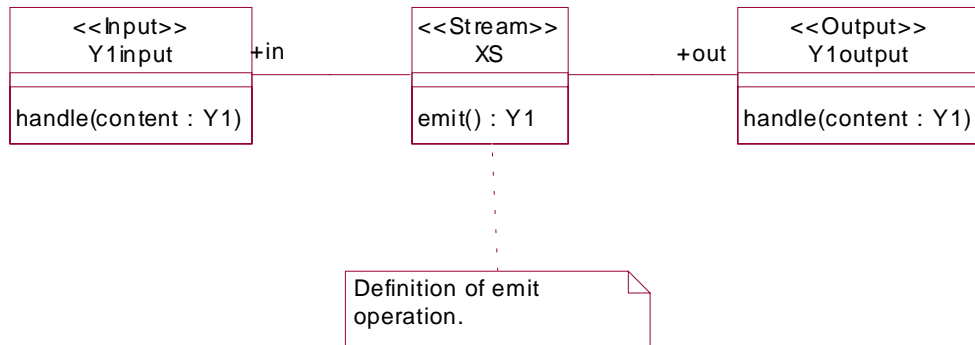

Figure 8-5 Class diagram for prototypical stream

Messages that arrive from the input terminal do not get passed on, but instead are stored in a buffer or some other appropriate data structure. The emit operation defines the algorithm used to decide when and in what order messages get emitted to the output terminal. Abstractly, one can imagine a loop that continually calls the emit operation. It returns a message to be put on the output terminal at each call. There may be a delay between its being called and its returning a message.

Constraints

The input terminal must be labeled in and the output terminal out.

The content format of the terminals must match that of the result of the emit operation. This type must have a stereotype <<MessageContent>> or one of its substereotypes.

8.3.5 Post Daters

Figure 8-6 shows the general format of the notation used to define a post dater.

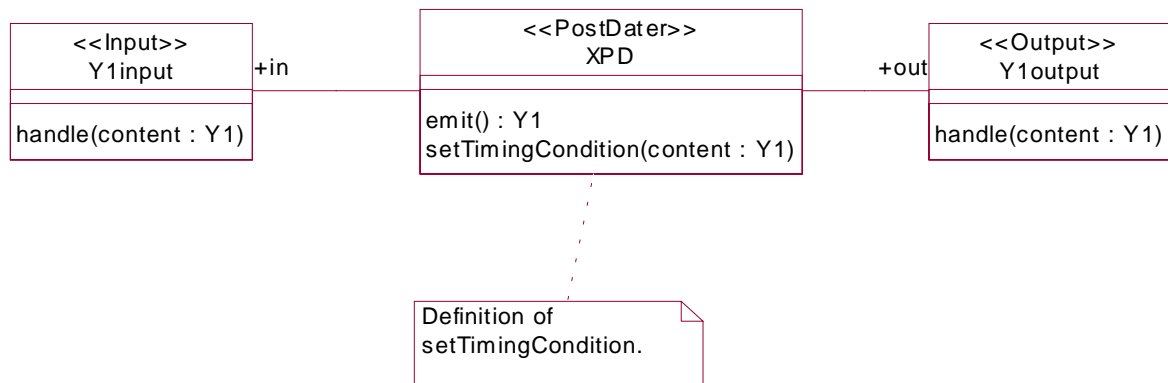

Figure 8-6 Class diagram for prototypical post dater

A post dater is specified using the <<PostDater>> stereotype. A special kind of stream is a post dater. On receipt of a message at its input terminal, it adds the message to the buffer, and creates an individual timingCondition for it. The timingCondition is derived from the content of the input message by the setTimingCondition operation. A post dater holds the message until its individual timing condition is met and then emits it from its out terminal.

As the definition for emit is fixed for post daters, only a definition for setTimingCondition should be provided.

Constraints

The input terminal must be labeled in and the output terminal out.

The content format of the terminals must match that of the result of the emit operation and the parameter of the setTimingCondition operation. This type must have a stereotype <<MessageContent>> or one of its substereotypes.

8.3.6 Source Adapters

Figure 8-7 shows the general format of the notation used to define a source adapter, which is represented by a class with stereotype <<SourceAdapter>>. A source adapter is an operator that obtains information from a system (e.g., vendor-supplied package or legacy application system), where that information might not be in a message content format, translates it into message content of a given output type and then sends out a message with that content.

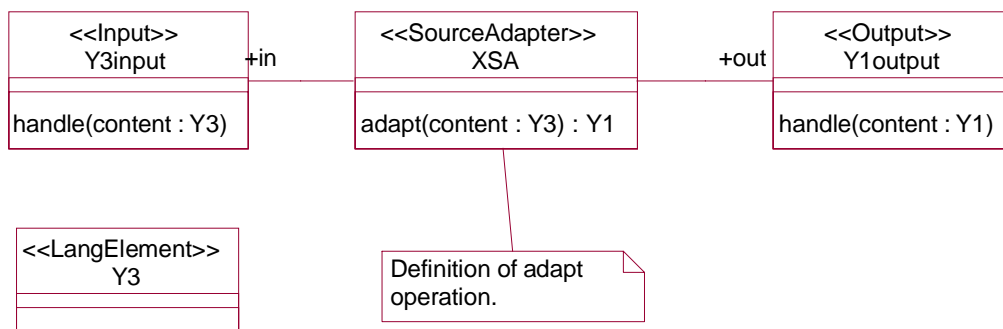

Figure 8-7 Class diagram for prototypical source adapter

When using a source adapter as a component of a compound operator (see Section 8.3.18, “Compound Operators,” on page 8-19), it is usually the case that its input terminal will not be connected to any other terminals. How information gets placed on that terminal is left unstated, since the internals of an application are out of scope for EAI modeling.

Constraints

The input terminal must be labeled in and the output terminal out.

The type of content in and out must match the type of the parameter and result, respectively, of the adapt operation.

The type of content of the out terminal must have a stereotype <<MessageContent>> or one of its substereotypes. The type of the content of the in terminal must have a stereotype <<LangElement>> or one its substereotypes.

8.3.7 Target Adapters

Figure 8-8 shows the general format of the notation used to define a target adapter, which is represented by a class with stereotype <<TargetAdapter>>. A target adapter is an operator that accepts messages and translates them into information for a system (e.g., vendor-supplied package or legacy application system), where that information might not be in a message content format.

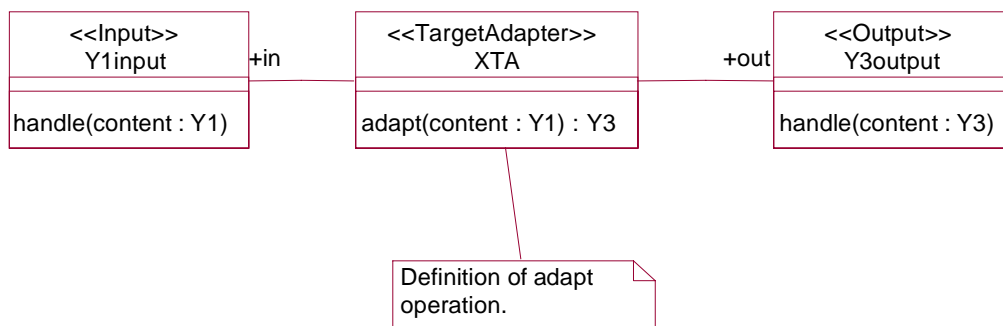

Figure 8-8 Class diagram for prototypical target adapter

When using a target adapter as a component of a compound operator (see Section 8.3.18, “Compound Operators,” on page 8-19), it is usually the case that its output terminal will not be connected to any other terminals. What happens to information after it leaves that terminal is left unstated, since the internals of an application are out of scope for EAI modeling.

Constraints

The input terminal must be labeled in and the output terminal out.

The type of content in and out must match the type of the parameter and result, respectively, of the adapt operation.

The type of content of the in terminal must have a stereotype <<MessageContent>> or one of its substereotypes. The type of the content of the out terminal must have a stereotype <<LangElement>> or one its substereotypes.

8.3.8 Call Adapters

Figure 8-9 shows the general format of the notation used to define a call adapter.

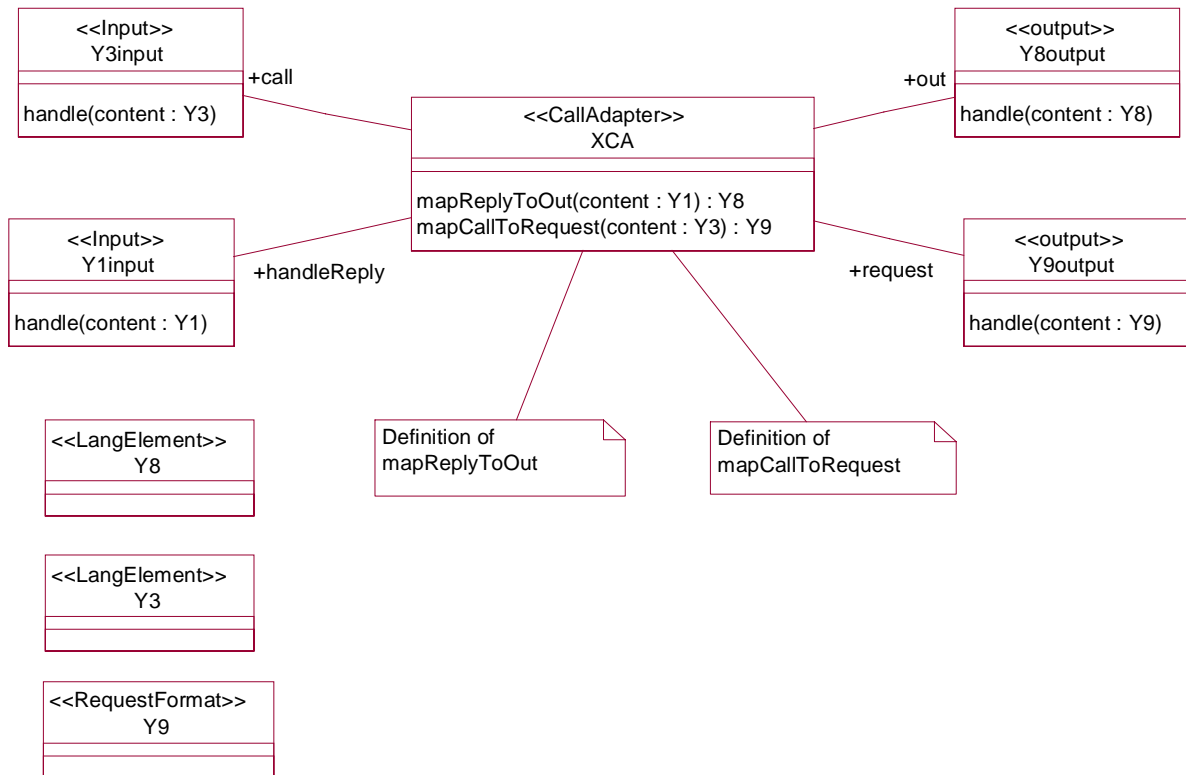

Figure 8-9 Class diagram for prototypical call adapter

A call adapter is invoked synchronously by an application that wishes to make use of a service (made available via a server) that can respond to a request message and send a response message back to the service requester. It accepts a call (which is not in a standard message format) on its call terminal and maps that call to a request message, which it sends to the request terminal. On receipt of a reply from the handleReply terminal, it maps that reply to a format understood by the application and places the result of the mapping on the out terminal.

A call adapter is used in conjunction with a request/reply adapter. See Section 8.3.18.4, “Call and Request/Reply Adapters,” on page 8-25 for details.

Constraints

The input terminals must be labeled call and handleReply, and the output terminals out and request.

The type of content of call and request must match the type of the parameter and result, respectively, of the mapCallToRequest operation.

The type of content of handleReply and out must match the type of the parameter and result, respectively, of the mapReplyToOut operation.

The type of content of the handleReply terminal must have a stereotype <<MessageContent>> or one of its substereotypes. The type of the content of the call and out terminals must have a stereotype <<LangElement>> or one its substereotypes. The type of content of the request terminal must have a stereotype <<RequestFormat>>.

8.3.9 Request/Reply Adapters

Figure 8-10 shows the general format of the notation used to define a request/reply adapter.

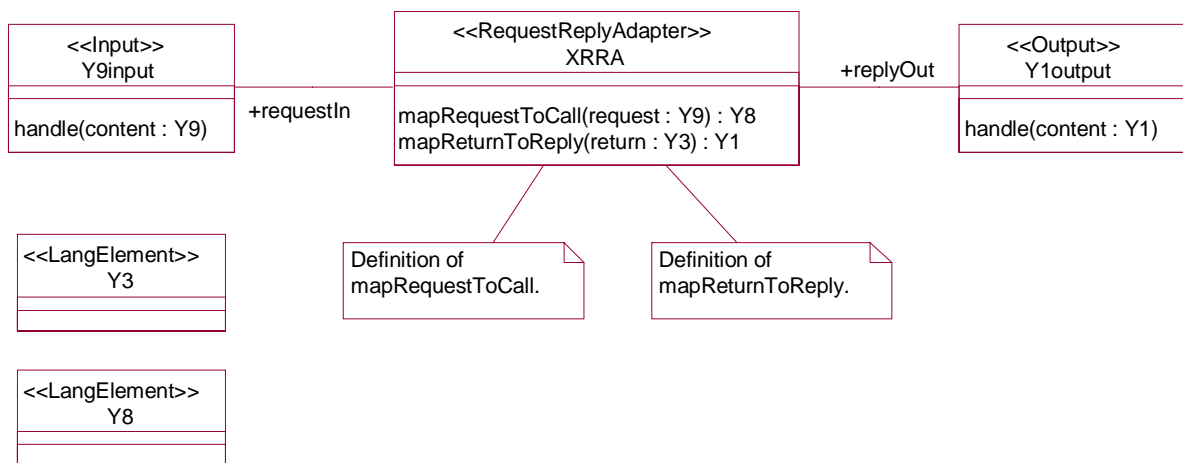

Figure 8-10 Class diagram from prototypical request/reply adapter

A request/reply adapter receives a request (from a call adapter) which contains both a terminal identifier and some other content. The mapRequestToCall operation extracts the information content of the request and converts it to a format suitable for passing to some underlying system. The mapReturnToReply operation takes the information returned from the system and constructs a message which is placed on the output terminal, but only after the terminal identifier in the original request has been added to the target list of its replyOut terminal. When the message has been sent, the terminal identified in the request message is removed from the target set of replyOut.

Note that any terminal permanently connected to the replyOut terminal will have replies of all requests broadcast to it.

A request/reply adapter is used in conjunction with a call adapter. See Section 8.3.18.4, “Call and Request/Reply Adapters,” on page 8-25 for details.

Constraints

The input terminal must be labeled `requestIn`, and the output terminal `replyOut`.

The type of content of `requestIn` and `replyOut` must match the type of the parameter of `mapRequestToCall` and the result of `mapReturnToReply`, respectively.

The type of content of the `replyOut` terminal must have a stereotype `<<MessageContent>>` or one of its substereotypes. The type of content of the `requestIn` terminal must have a stereotype `<<RequestFormat>>`. The type of the result of `mapRequestToCall` and the parameter of `mapReturnToReply` must have a stereotype of `<<LangElement>>` or one of its substereotypes.

8.3.10 Sources and Queued Sources

Figure 8-11 shows the general format of the notation used to define a source, which is represented by a class with stereotype `<<Source>>`. A source is an operator that delivers message content to an output terminal. How that message content is constructed, or where it comes from, is not stated.

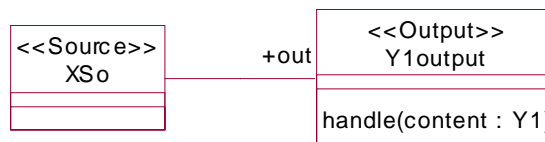

Figure 8-11 Class diagram for prototypical source

A queued source is a source that has a `<<Queue>>` resource. It is identified by the stereotype `<<QSource>>`, as illustrated by Figure 8-12.

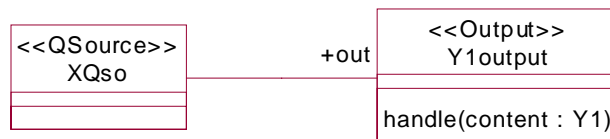

Figure 8-12 Class diagram for prototypical queued source

Constraints

There is a single output terminal labeled `out`.

The type of content of `out` must have a stereotype `<<MessageContent>>` or one of its substereotypes.

For queued sources, there must be a directed association to a queue resource (i.e., a class with stereotype `<<Queue>>`). This should be labeled `queue`.

8.3.11 Sinks and Queued Sinks

Figure 8-13 shows the general format of the notation used to define a sink, which is represented by a class with stereotype `<<Sink>>`. A *sink* is an operator that receives message content from an input terminal. What happens to that content thereafter is left unsaid.

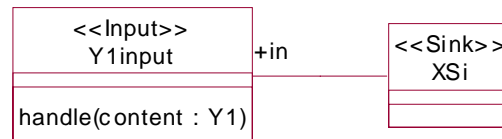

Figure 8-13 Class diagram for prototypical sink

A queued sink is analogous to a queued source, and is identified by the stereotype `<<QSink>>`.

Constraints

There is a single input terminal labeled in.

The type of content of in must have a stereotype `<<MessageContent>>` or one of its substeretypes.

For queued sinks, there must be a directed association to a queue resource (i.e., a class with stereotype `<<Queue>>`). This should be labelled queue.

8.3.12 Aggregators

Figure 8-14 shows the general format of the notation used to define an aggregator.

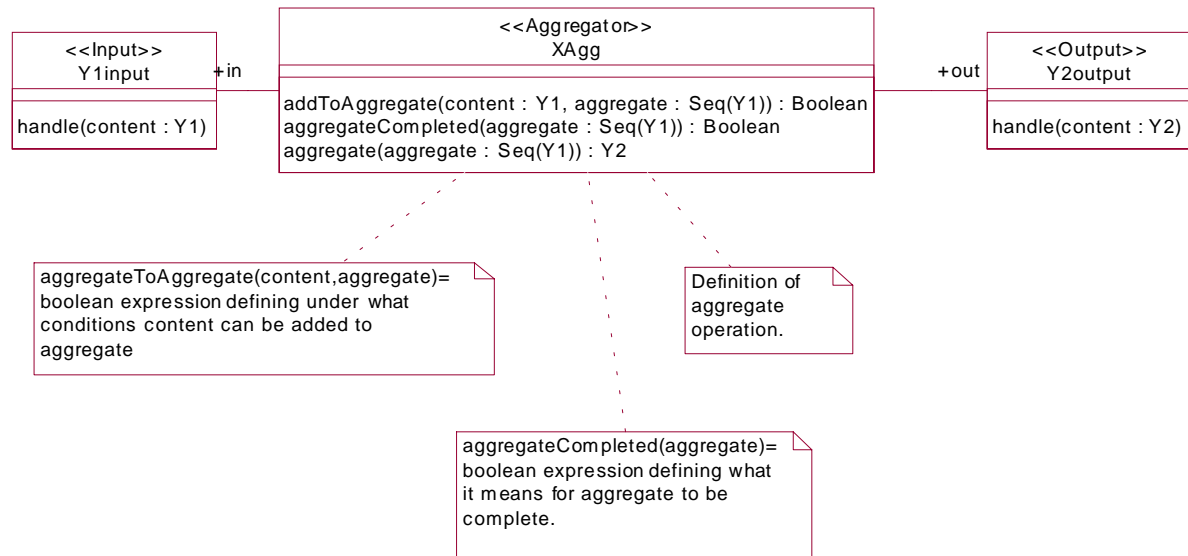

Figure 8-14 Class diagram for prototypical aggregator

An aggregator operator is indicated by the <<Aggregator>> stereotype. On receipt of a message at its input terminal, if there are no existing message aggregates, the aggregator creates one and adds the message to it. On receipt of a subsequent message, the aggregator examines each existing aggregate, evaluating the `addToAggregate` condition (which will depend on the message header or body contents). If an aggregate exists for which `addToAggregate` evaluates to true, then the message is added to it.

Each time a message is added to an aggregate, the `aggregateComplete` condition is evaluated for that aggregate. If it evaluates to true, then a message is constructed from the messages it holds and is sent on the output terminal. The mapping from the messages contained in the aggregate to the message sent is specified by the `aggregate` operation.

If the `aggregateComplete` condition does not evaluate to true, then no message is sent.

Constraints

The input terminal must be labeled in and the output terminal out.

The content format of in and out must match the format of the parameter and result, respectively, of the transform operation.

The type of content of the terminals must have a stereotype <<MessageContent>> or one of its substereotypes.

8.3.13 Timers

Figure 8-15 shows the general format of the notation used to define a timer.

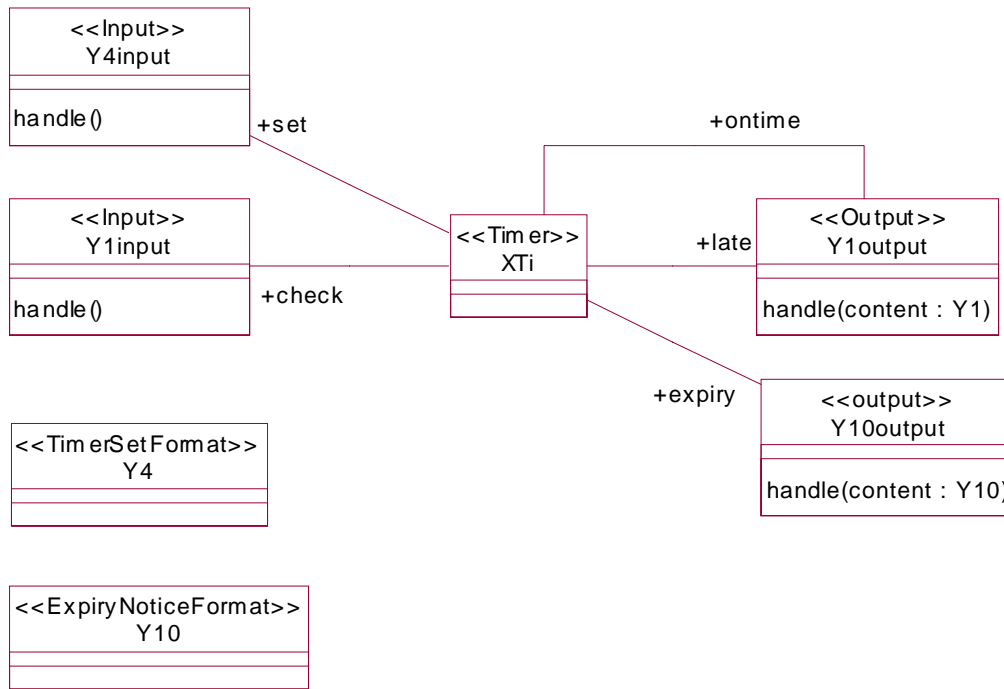

Figure 8-15 Class diagram for prototypical timer

A timer is specified using the <<Timer>> stereotype. It processes a message on its set terminal that specifies a timer set message which contains a pair comprising a timer and a correlation condition. This gets added to the timer's list of condition pairs. When a timer receives a message from the check terminal, it looks through its list of condition pairs and sees if the message satisfies any of the correlation conditions. If so, then the timer condition is examined to see if it has been met, and, if so, the message is passed onto the ontime terminal. Otherwise it is passed onto the late terminal. If it does not meet any correlation condition, it is assumed the message is on time and therefore passed onto the ontime terminal.

Whenever a timer condition from the list of condition pairs expires, an expiry notice is sent to the expiry terminal.

Constraints

The input terminals must be labelled set and check. The output terminals must be labelled ontime, late and expiry.

The content format of the check, late and ontime terminals must be the same. This type must have stereotype <<MessageContent>> or one of its substereotypes.

The type of content of the set terminal must have a stereotype <<TimerSetFormat>>.

The type of content of the expiry terminal must have a stereotype <<ExpiryNoticeFormat>>.

8.3.14 Routers

Figure 8-16 shows the general format of the notation used to define a router.

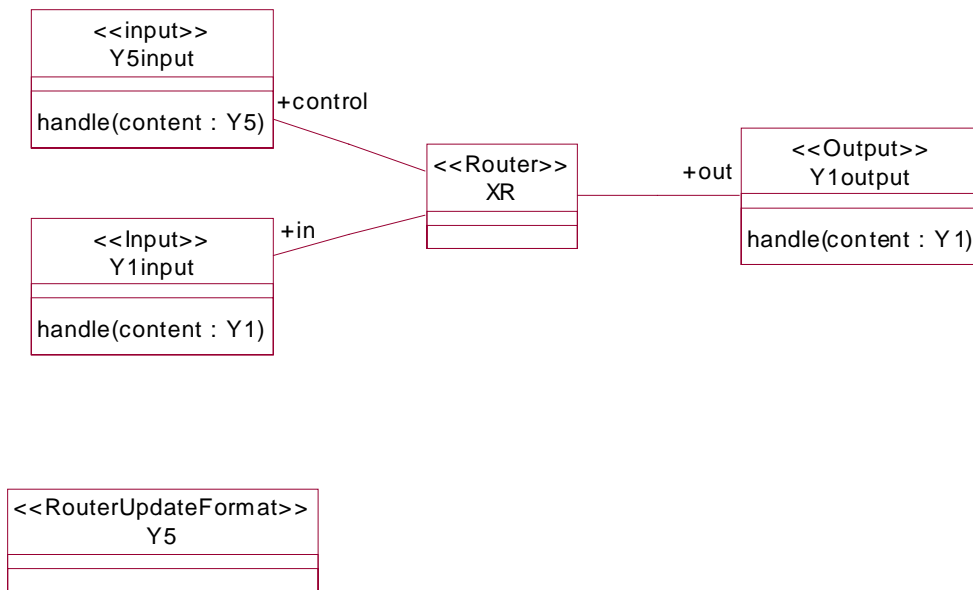

Figure 8-16 Class diagram for prototypical router

A router is specified using the <<Router>> stereotype. When a router receives a message on its in terminal it resends a copy via its out terminal, so that all connected input terminals receive the message.

In addition, a router can accept dynamic addition or removal of target terminals to or from its out terminal, and so it can be used to model a simple publication channel for messages. This is achieved by sending a message with content that is in a router-update format to its control terminal.

Constraints

The input terminals must be labeled in and control. The output terminal must be labeled out.

The type of content of the in and out terminals of a router must have a stereotype <<MessageContent>> or one of its substereotypes. The type of content of the control terminal must have a stereotype <<RouterUpdateFormat>>.

8.3.15 Subscription Operators

Figure 8-17 shows the general format of the notation used to define a subscription operator.

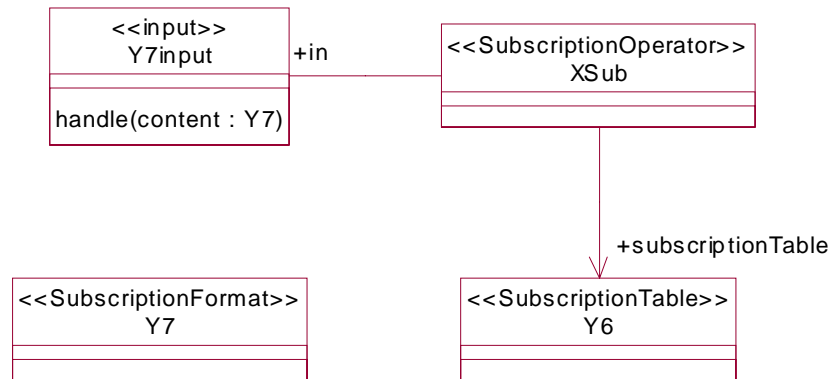

Figure 8-17 Class diagram for prototypical subscription operator

A subscription operator is specified using the stereotype <<SubscriptionOperator>>. It expects a message of subscription format as input. This carries a subscription comprising a terminal identifier and a filter definition. When it receives one of these messages, it adds the subscription to its subscription table. A subscription message may also request subscriptions for a terminal to be canceled.

Constraints

The single input terminal must be labeled in.

The type of content of the in terminal must have a stereotype <<SubscriptionFormat>>.

There must be a directed association to a subscription table (i.e., a class with stereotype <<SubscriptionTable>>). This should be labeled subscriptionTable.

8.3.16 Publication Operators

Figure 8-18 shows the general format of the notation used to define a publication operator.

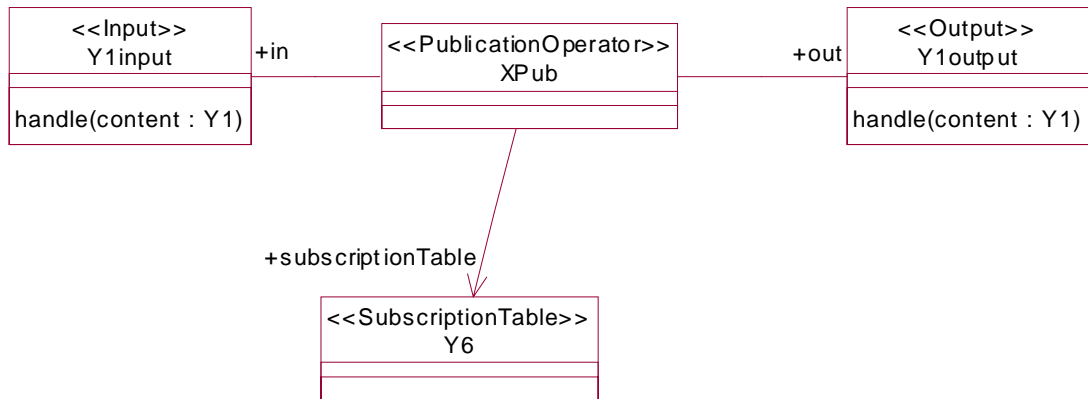

Figure 8-18 Class diagram for prototypical publication operator

A publication operator is specified using the stereotype <<PublicationOperator>>. Messages sent to the input terminal are sent from the output terminal to each subscriber (terminal) if the message passes the filter specified by the subscription for that subscriber.

A publication operator is accompanied by at least one subscription operator when defined as part of an architecture. See Section 8.3.18.5, “Publish and Subscribe,” on page 8-25 for details.

Constraints

The input terminal must be labeled in, and the output terminal out.

The type of content of both terminals must be the same and have a stereotype <<MessageContent>> or one of its substereotypes.

There must be a directed association to a subscription table (i.e., a class with stereotype <<SubscriptionTable>>). This should be labeled subscriptionTable.

8.3.17 Topic Publishers

Figure 8-19 shows the general format of the notation used to define a topic publisher.

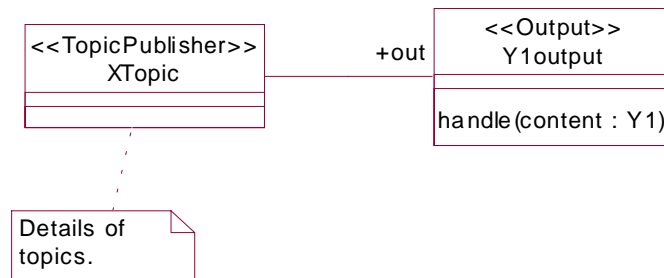

Figure 8-19 Class diagram for prototypical topic publisher

A topic publisher is specified using the stereotype <<TopicPublisher>>. It is kind of source, which sends only sends messages to the output terminal on a set of specified topics. Details about the topics may be added as a note. The content type of the output terminal may also be an indicator of the kinds of topics published on.

Topic publishers are usually connected to the input terminal of a publication operator. See Section 8.3.18, “Compound Operators,” on page 8-19 for details.

Constraints

The single output terminal must be labeled out.

The type of content of this terminal must have a stereotype <<MessageContent>> or one of its substereotypes.

8.3.18 Compound Operators

Compound operators allow more complex message transformation and routing behavior from a (possibly nested) composition of individual operators to be modeled. Indeed any non-trivial architecture will be modeled as a compound operator whose components will be primitive or other compound operators.

Compound operators are defined using a combination of class and collaboration diagrams.

8.3.18.1 Class diagrams

Figure 8-20 shows the class diagram for an example compound operator, which is specified using the stereotype <<CompoundOperator>>. The example is taken from Chapter 10.

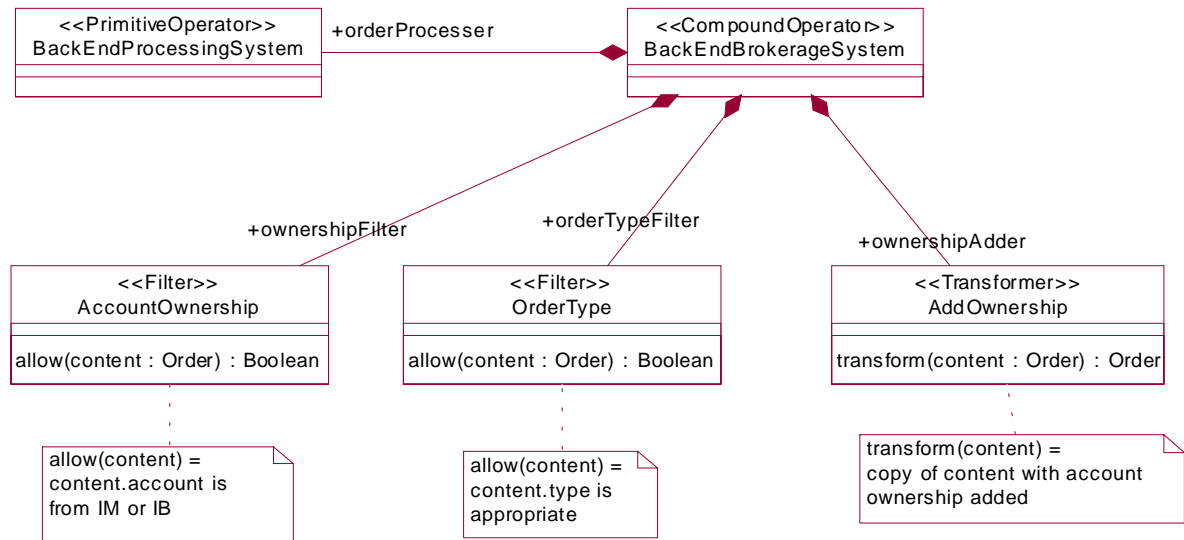

Figure 8-20 Class diagram for example compound operator

This defines a compound operator called BackEndBrokerageSystem with three components: two filters and a transformer. The primitive operator, filters and transformers are defined as previously discussed. Components are shown by means of a composite association targeted on a class representing an operator definition. Although the components shown here are all primitive operators, they may be compound operators, as illustrated by Figure 8-21.

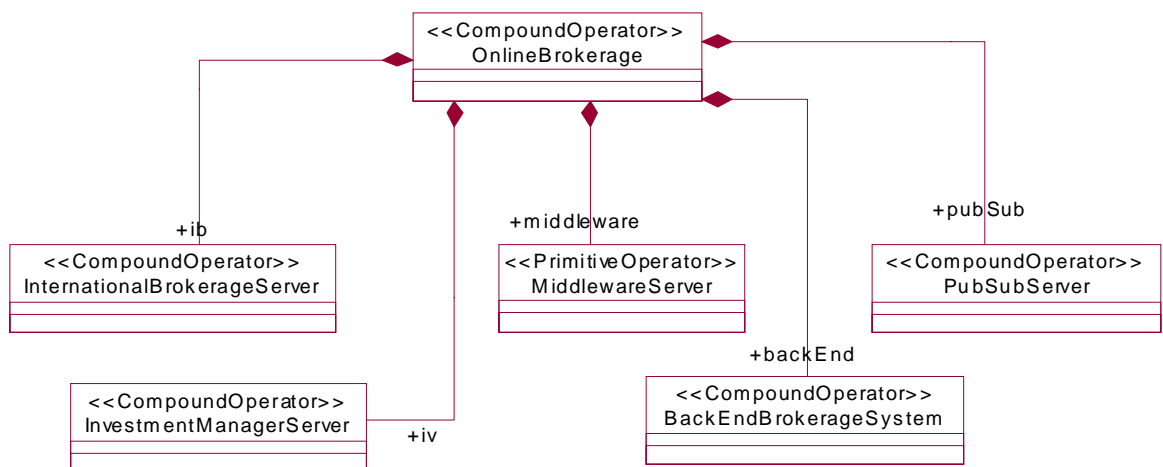

Figure 8-21 Class diagram for a compound operator with compound components

Note, in this diagram, that one component of an OnlineBrokerage is a BackEndBrokerageSystem, which, as we have already seen, is a compound operator.

As with primitive operators, class diagrams can also be used to define the terminals of a compound operator. The terminals of BackEndBrokerageSystem are defined by Figure 8-22.

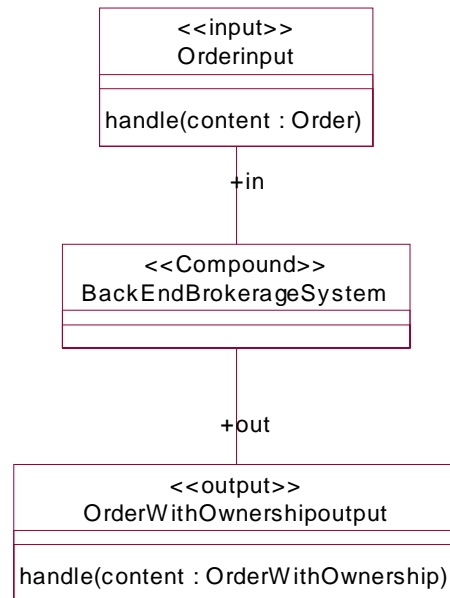

Figure 8-22 Terminals for example of compound operator

Figure 8-22 does not show the connectivity of the components, that is, how the terminals of the components are connected together and connected to the terminals of the compound operator. A collaboration diagram is used to show the connectivity of the components.

8.3.18.2 Collaboration Diagrams

The collaboration diagram corresponding to Figure 8-20 is given in Figure 8-23.

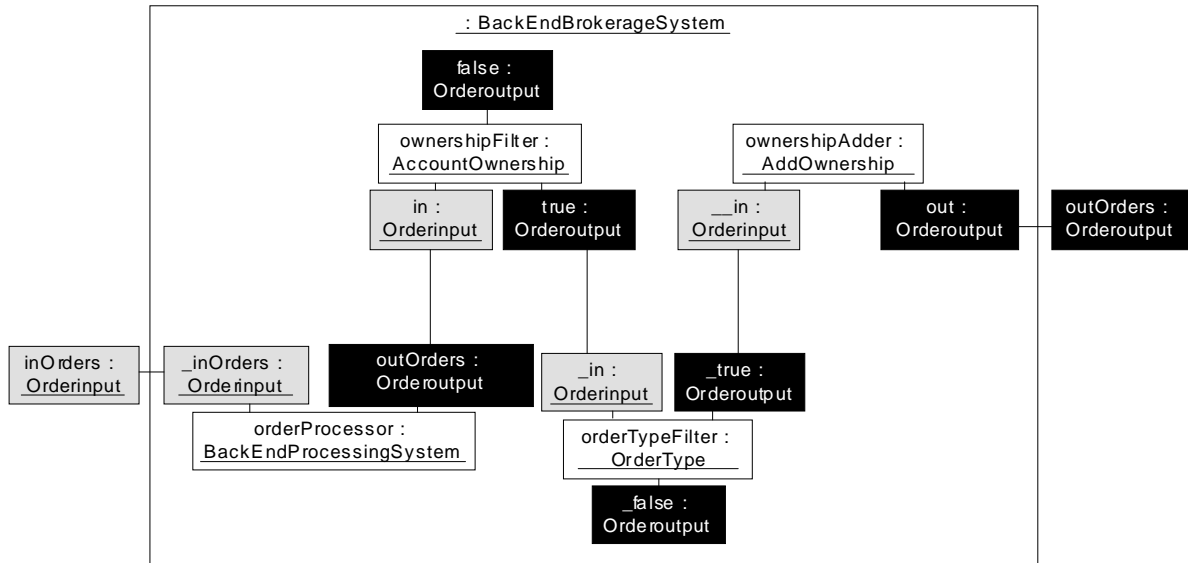

Figure 8-23 Collaboration diagram for example compound operator

This shows:

- The components of the compound as objects contained in an object representing the compound
- The terminals of the components (also contained in the compound), and the terminals of the compound itself (outside the compound).

The names of the objects correspond to the names of the components or terminals, as declared on the class diagram. The compound object has no name, as it represents an arbitrary operator of the compound-operator type being defined. We have used gray (or black) to distinguish input (or output) terminals from operators; this is just a convention. Connection of components is shown by connecting the terminals in an appropriate way (see Section 8.3.18.6, “Constraints,” on page 8-26 for a definition of what is appropriate). Ownership of terminals by an operator is also shown through links; the convention is to cluster terminals around their operator.

Sometimes one may wish to be explicit about whether the connection between terminals is synchronous or asynchronous. This is shown by putting a message on the link, which is marked as asynchronous or synchronous. Figure 8-24 shows the standard UML notation for this.

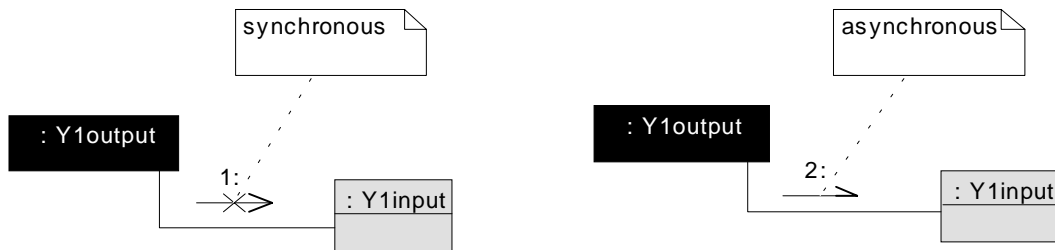

Figure 8-24 Synchronous and asynchronous links

The arrow of the message goes in the direction of the message flow (output to input when terminals of components of a compound are connected).

8.3.18.3 Components of the same type

A situation that the modeler should be aware of is the case where a compound may include two components of the same type of operator. This is illustrated by Figure 8-25 and Figure 8-26. The point to note is that there are two components of StandardIBSystem operator type (which is evident from the two associations to the StandardIBSystem class on the class diagram) and two objects of this class on the collaboration diagram.

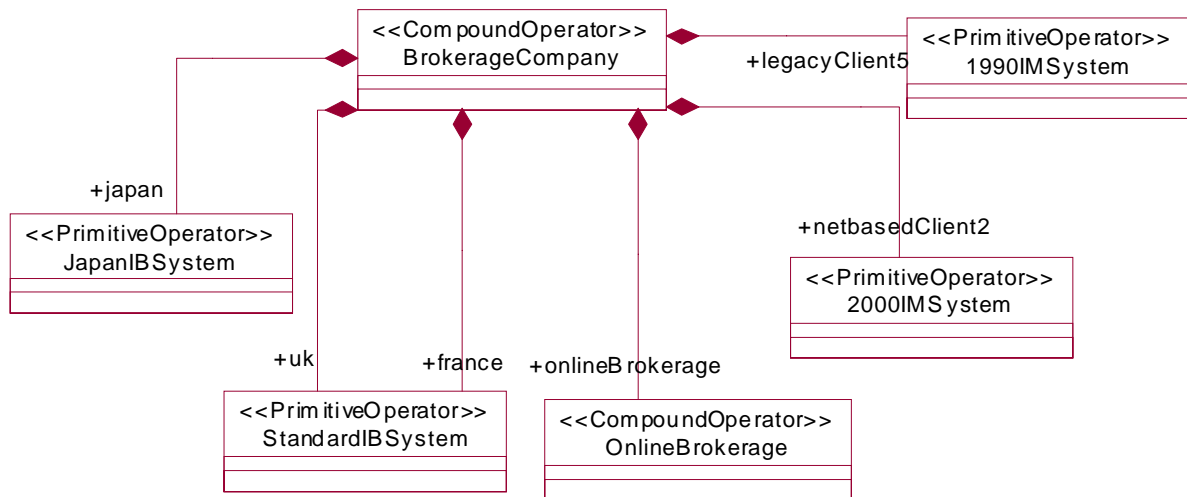

Figure 8-25 Class diagram for example with components of same type

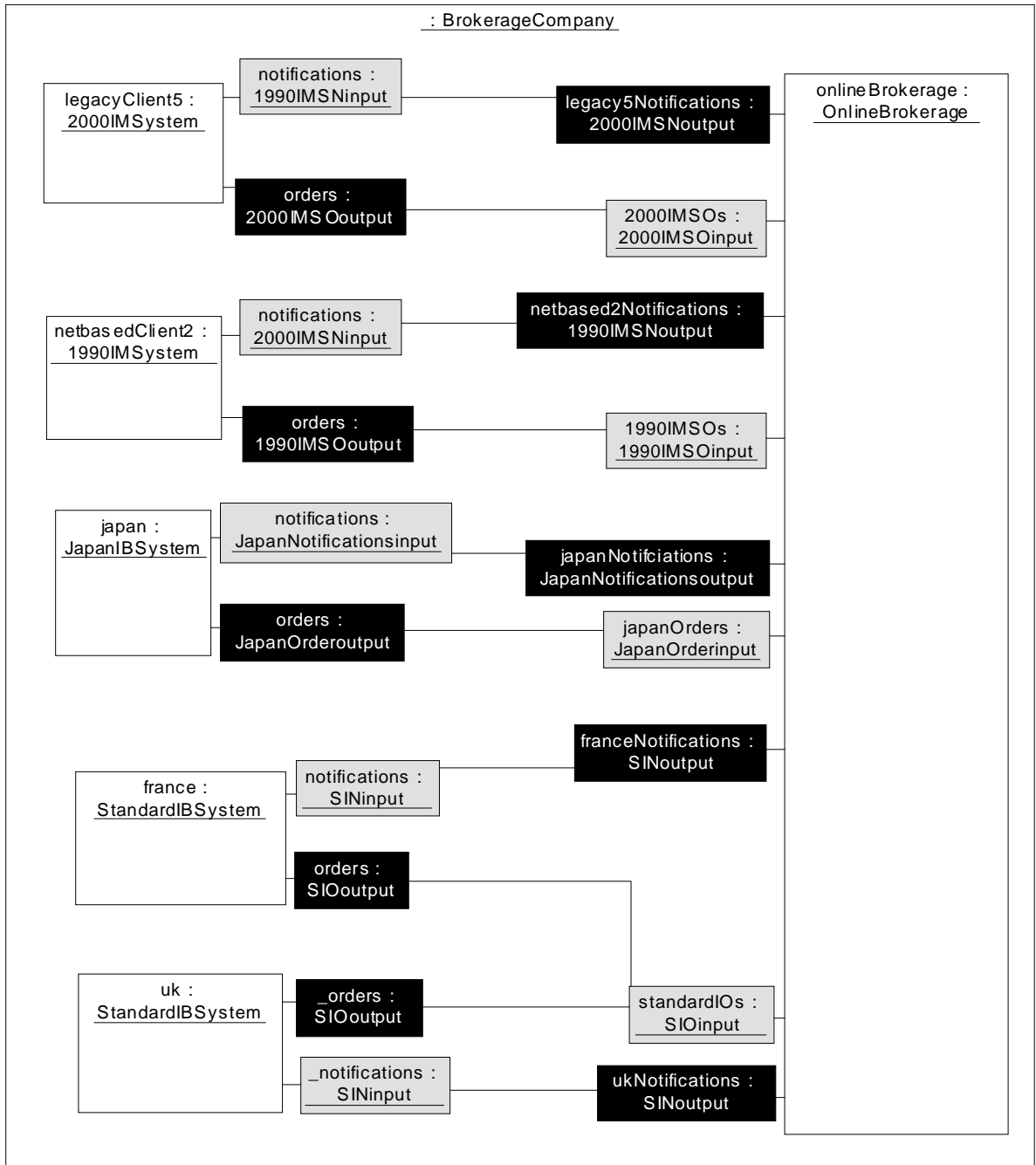

Figure 8-26 Collaboration diagram for example with components of same type.

This example happens to illustrate the top-level definition of an EAI architecture, in this case for a brokerage company.

8.3.18.4 Call and Request/Reply Adapters

A common configuration of components is the connection of call and request/reply adapters. This is illustrated by Figure 8-27.

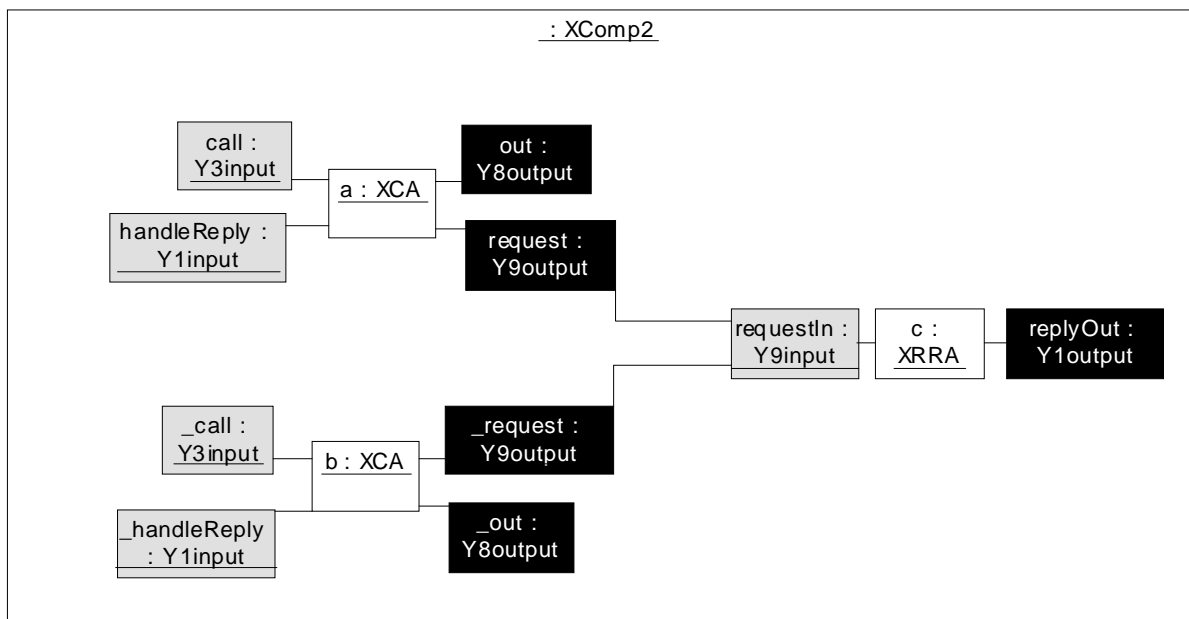

Figure 8-27 Configuration of call and request/reply adapters

Here, two call adapters (a and b) are connected to a single request/reply adapter (c). The call adapters get information from an underlying system through their call terminals. They construct requests that are then passed on to the `requestIn` terminal of the request/reply adapter. This processes the request, usually by making a call to some underlying system, and then constructs a reply, which it puts on its `replyOut` terminal. Before sending the reply, the original request is examined to identify the terminal to which the reply must be sent (which will be the `handleReply` terminal for a or b, depending on which one sent the request), and this is added to the target terminals list of `replyOut`, just for the duration of sending the reply.

8.3.18.5 Publish and Subscribe

Another common configuration of components is the connection of publication and subscription operators. This is illustrated by Figure 8-28.

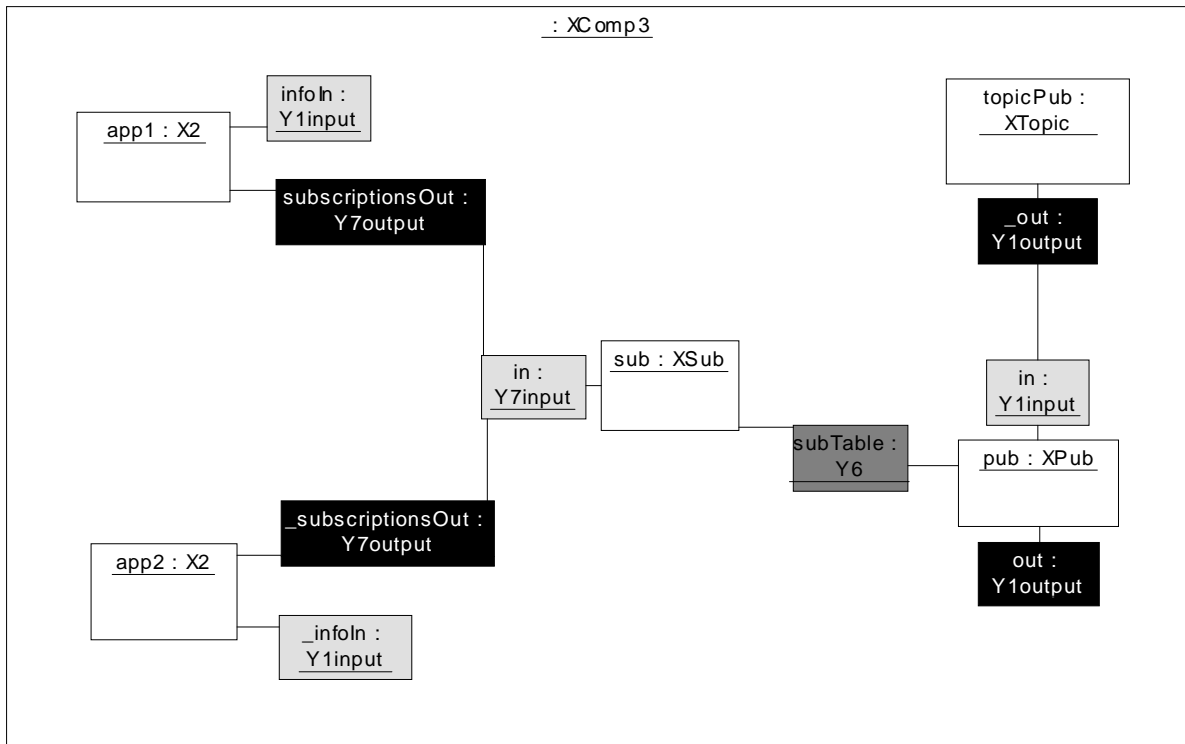

Figure 8-28 Configuration of publication and subscription operators

A publication operator `pub` is fed information to publish by a topic publisher `topicPub`. The feed is provided by the connection of the `out` terminal of `topicPub` to the `in` terminal of `pub`. Now `pub` has a subscription table (`subTable`) which it shares with the subscription operator `sub`. Two applications, `app1` and `app2`, send subscription requests to `sub`. The subscription requests will identify their `infoIn` terminals as the terminals where published information, matching the criteria of the subscriptions, should be received.

A more sophisticated (and more common) version of this example would have multiple topic publishers feeding messages to the publication operator. Then multiple publishers would share the subscription table of the subscription operator.

8.3.18.6 Constraints

Only operators with stereotype `<<Compound>>` can have composition associations, and these must be with other operators (classes with an operator stereotype). The associations have a label but no indication of cardinality.

The type of content of the terminals must have a stereotype `<<MessageContent>>` or one of its substeratypes.

The class and collaboration diagrams used to notate a compound operator must be consistent. This means:

- Names of terminal objects must match the labels on terminal associations on the class diagram. The types of the object must correspond to the terminal classes defined in the class diagram.
- Names of component operator objects must match the labels on the composition associations on the class diagram. The types of the objects must correspond to the operator classes at the target of those associations as defined on the class diagram.

On the collaboration diagram, only output terminals may be connected to input terminals of other components. Input (output) terminals of the compound operator may only be connected to input (output) terminals of components.

The content type handled by terminals must be the same for any two terminals connected together on the collaboration diagram.

8.4 Resources

Resources are things that operators use to do their job, but which are not themselves operators. The specific resources declared in this profile are databases, queues and subscription tables.

Resources are defined as classes with stereotype <<Resource>> or one of its substeretypes: <<Database>>, <<Queue>> and <<SubscriptionTable>>.

The use of a resource by an operator is indicated, in the class diagram defining that operator, by a directed association from the operator to the resource. See Section 8.3.2, “Transformers and Database Transformers,” on page 8-4 and Section 8.3.15, “Subscription Operators,” on page 8-17 for examples.

When operators with resources are used as part of a compound, they may share a resource. This is shown by adding an object of the resource class and connecting the sharing operators to it with a link. See Section 8.3.18.5, “Publish and Subscribe,” on page 8-25 for an example.

8.5 Message Formats

8.5.1 MessageContent Core

The data contained in a message is its MessageContent. Messages are defined using ordinary UML class modeling mechanisms. However, message content classes are restricted to represent transmittable data structures.

The model for messages is that they may contain one or more parts, each of which may have its own header part. The header contains information used by the messaging infrastructure to control how it deals with the message. Each message part may also have a body section, which contains the application data. Message parts may be nested.

Both the header and the body may contain nested structures of primitive message elements.

We formalize these restrictions using the UML stereotypes given in Table 8-1. A class of the <<MessageContent>> stereotype represents a serialized message. To reflect the ordering of the parts of a message, there are additional constraints:

1. All associations are ordered with respect to each other.
2. Associations of multiplicity greater than one are ordered.

For example, a message header usually occurs in a message part before the message content.

Table 8-1 Stereotype specification for message content description

Stereotype	Parent	Tags	Constraints	Description
MessageContent	N/A	domainformat	May only have containment associations with classes of stereotype <<MessagePart>> or <<ComposedMessagePart>>	Top level for describing messages (such as a MIME envelope)
MessagePart	N/A	NA	May only be composed by a class of stereotype <<MessageContent>>May contain a 'header' association with a class of stereotype <<MessageElement>>May contain a 'body' association with a class of stereotype <<MessageElement>>	Used to describe 'large scale' message structuring (such as MIME parts)
ComposedMessagePart	MessagePart	NA	May have associations with classes of stereotype <<MessagePart>> and of stereotype <<ComposedMessagePart>>	Used to describe nested message parts
LangElement	NA	NA		Models message headers, message bodies and their content

Figure 8-29 shows an example of a content class with two data items, an integer and a string. These simple message parts have been rendered as attributes of the owning SimpleContent class. This is recommended in order to allow compact representation of simple message types.

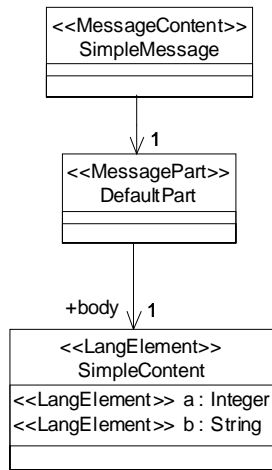

Figure 8-29 A simple message content class

More complicated message-content structures can be created using composition, as is shown in Figure 8-30. This models a message which has a single part. The message has as its header a string, while the message body is a table of addresses. This table has a single integer, records, that is a count of the records in the message.

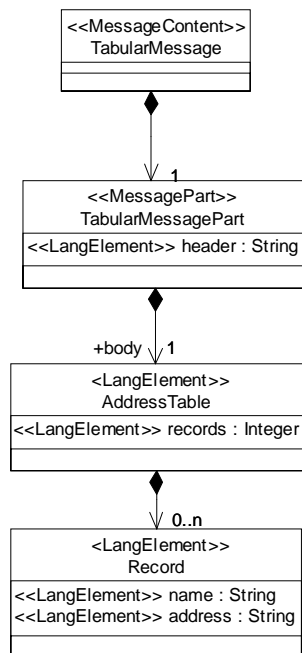

Figure 8-30 A model of a message containing a table

8.5.2 Basic MOM Message Structure

The stereotypes given in the preceding section provide the framework to allow messages to be specified, but they do not cover commonly occurring concepts supported by message oriented middleware (MOM) products.

In this section we add the basic concept of an exception message, a message sent by the messaging infrastructure when a fault occurs in the processing of a message. We also define a MOMHeader, which can specify an exception target (the location to which a message should be sent in the event of an exception) and a reply target, and it can identify the kind of message being sent.

Table 8-2 Stereotype specification for MOM structure

Stereotype	Parent	Tags	Constraints	Description
MOMHeader	MessageElement	NA	May have an association 'replyTo' with a <<MessageElement>> class that specifies a reply target and another 'exceptionTarget' with a <<MessageElement>> class that specifies an exception target	Stereotype to capture common MOM header information
ExceptionNotice	MessageContent	NA	May have a message part containing the header and body of the message that caused the fault	Message sent by the MOM infrastructure if a fault occurs while processing a message

8.5.2.1 ExceptionNotice

Figure 8-31 illustrates the usage of the ExceptionNotice stereotype. In this example, we have defined a class MOMException, which models the message content of an exception message created by a MOM system after a fault has occurred. MOMException contains two associations to classes that conform to the MessagePart stereotype:

- originalMessage is an association to a class that models the content of the message that caused the exception. In this case, the original message had just one message part. If the original message had contained several parts, it would be possible to model originalMessage as a class that conforms to the ComposedMessagePart stereotype.
- exceptionInformation is an association to a message part that contains only exception header information. The exception header holds information that identifies the exception type and a string that describes the exception.

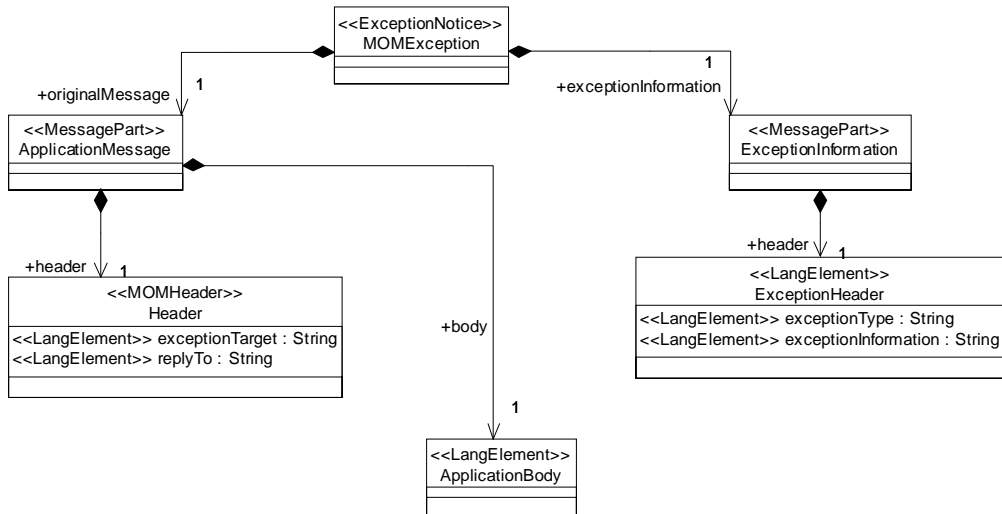

Figure 8-31 Example of the use of the ExceptionNotice and MOMHeader stereotypes

8.5.2.2 MOMHeader

The MOMHeader stereotype demands that a message header must identify the following elements, but does not dictate how they are represented in the message:

- replyTo: a means of identifying a location to send a reply message to
- exceptionTarget: a means of identifying a location to send an exception notice in the event of a fault occurring in the processing of a message

Figure 8-32 demonstrates an example of the use of the MOMHeader stereotype. In this case, the domain and format are both identified using strings, and the exceptionTarget and replyTo header content are specified using the MOMEndpointSpec class. In a particular MOM implementation, this information should allow an EAI terminal to be identified.

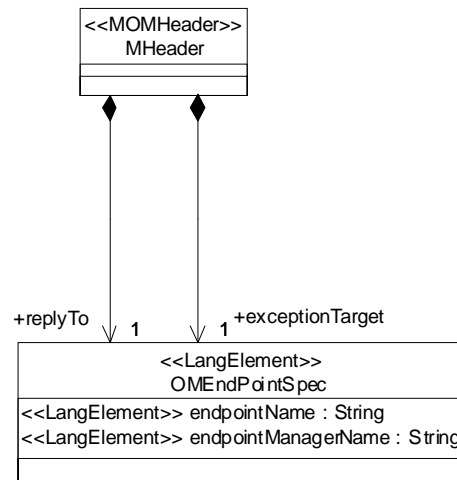

Figure 8-32 Example of the use of the MOMHeader stereotype

8.6 Mapping with Metamodel

The mapping with the metamodel is summarized by a series of tables, which are organized below into sections corresponding to the four main parts of the profile: terminals, operators, resources and message formats.

These tables are based on the approach specified in UML 1.4. for defining stereotypes for use in a profile. We have extended them to show the mapping to the EAI metamodel. Thus the tables also serve to summarize the stereotypes used in the profile.

In addition to the tables, we have detailed important mapping constraints which dictate how information associated with an instance of an EAI metaclass is related to information associated with an instance of the stereotyped UML base class. These are listed below the relevant tables.

The mapping constraints should be distinguished from constraints that apply to the use of the profile itself (e.g., the use of a particular stereotype). Those are defined in the section describing that aspect of the profile.

8.6.1 Terminals

Table 8-3 Mapping of terminals

EAI Metaclass	Base class	Stereotype	Parent	Description & constraints
EAITerminal	Core::Association			See Section 8.2
	Core::Class	Input or Output		See Section 8.2
EAIQueuedInputTerminal	Core:: Association			See Section 8.2
	Core::Class	QInput	Input	See Section 8.2
EAIQueuedOutputTerminal	Core:: Association			See Section 8.2
	Core::Class	QOutput	Output	See Section 8.2

Mapping Constraints

EAITerminal

1. This mapping is valid only for terminals which belong to operators that define types.
2. The association is sourced on the class corresponding to the operator to which the terminal belongs; it is targeted on the class identified with the terminal.
3. The handle operation of the class must have a parameter of a type corresponding to the type of the parameter associated with the terminal.
4. Different terminals may map to the same class (but not the same association).
5. The name of the terminal is the name of the target end of the association.
6. The stereotype of the class corresponds to the value of the terminalKind attribute of the terminal.

EAIQueuedInputTerminal and EAIQueuedOutputTerminal

There are no additional constraints.

8.6.2 Operators

Operators and terminals in the metamodel are used in two roles. Firstly they are used to define types and parameters; secondly they are used to define the connectivity of a compound operator in its role in defining a type. The mapping of operators has been split into two parts, reflecting the two different roles. The first part deals with all operators, except compound operators. The second part deals with compound operators, which, as suggested above, requires a second mapping of operators and terminals to be defined.

Table 8-4 Mapping of operators (except compound)

EAI Metaclass	Base class	Stereotype	Parent	Description & constraints
EAIPrimitiveOperator	Core::Class	PrimitiveOperator		See Section 8.3.1
EAITransformer	Core::Class	Transformer	PrimitiveOperator	See Section 8.3.2
EAIIDBTransformer	Core::Class	IDBTransformer	Transformer	See Section 8.3.2
EAIFilter	Core::Class	Filter	PrimitiveOperator	See Section 8.3.3
EAIStream	Core::Class	Stream	PrimitiveOperator	See Section 8.3.4
EAIPostDater	Core::Class	PostDater	Stream	See Section 8.3.5
EAISourceAdapter	Core::Class	SourceAdapter	PrimitiveOperator	See Section 8.3.6
EAITargetAdapter	Core::Class	TargetAdapter	PrimitiveOperator	See Section 8.3.7
EAIAdapter	Core::Class	Adapter	PrimitiveOperator	See Section 8.3.8
EAIRequestReplyAdapter	Core::Class	RequestReplyAdapter	PrimitiveOperator	See Section 8.3.9
EAISource	Core::Class	Source	PrimitiveOperator	See Section 8.3.10
EAIQueuedSource	Core::Class	QSource	Source	See Section 8.3.10
EAI Sink	Core::Class	Sink	PrimitiveOperator	See Section 8.3.11
EAIQueuedSink	Core::Class	QSink	Sink	See Section 8.3.11
EAI Aggregator	Core::Class	Aggregator	PrimitiveOperator	See Section 8.3.12
EAI SubscriptionOperator	Core::Class	SubscriptionOperator	PrimitiveOperator	See Section 8.3.15
EAI PublicationOperator	Core::Class	PublicationOperator	PrimitiveOperator	See Section 8.3.16
EAI TopicPublisher	Core::Class	TopicPublisher	PrimitiveOperator	See Section 8.3.17

Mapping Constraints

EAIPrimitiveOperator

7. This mapping is only valid for primitive operators defining a type (not ones used to show connectivity of components).
8. The name of operator (and hence the type which the operator defines) is the name of the class.
9. There must be an association on the class diagram corresponding to each terminal of the primitive operator.

EAITransformer

10. The transformation mapping of the operator maps to the operation transform, in the class corresponding to the operator.

EAIIDBTransformer

11. The database resource maps to the database association sourced on the class corresponding to the operator.

EAIFilter

12. The filterCondition of the operator maps to the allow operation in the corresponding class.

EAIStream

13. The emissionCondition of the operator maps to the emit operation in the corresponding class.

EAIPostDater

14. The timerMapping of the operator corresponds to the setTimingCondition operation in the corresponding class.

EAISourceAdapter and EAITargetAdapter

15. The internalToMessage (resp. messageToInternal) mapping for the operator corresponds to the adapt operation in the corresponding class.

EAIAdapter

16. The callToRequestMapping of the operator corresponds to the mapCallToRequest operation in the corresponding class.
17. The replyToOutMapping of the operator corresponds to the mapReplyToOut operation in the corresponding class.

EAIRequestReplyAdapter

18. The requestToCallMapping of the operator corresponds to the mapRequestToCall operation in the corresponding class.
19. The returnToReplyMapping of the operator corresponds to the mapReturnToReply operation in the corresponding class.

EAISource, EAIQueuedSource, EAI Sink, EAIQueuedSink

There are no further constraints.

EAI Aggregator

20. The aggregateComplete condition of the operator corresponds to the aggregateComplete operation in the corresponding class.
21. The addToAggregate condition of the operator corresponds to the addToAggregate operation in the corresponding class.
22. The aggregationMapping of the operator corresponds to the aggregate operation in the corresponding class.

EAI Subscription Operator and EAI Publication Operator

23. The subscriptionTable resource maps to the subscriptionTable association sourced on the class corresponding to the operator.

TopicPublisher

There are no further constraints.

A compound operator utilizes a graph of operators, terminals and resources to define the connectivity of its components. This is exposed by the mapping defined in Table 6.

Table 8-5 Mapping of compound operator

EAI Metaclass	Base class	Stereotype	Parent	Description & constraints
EAICompoundOperator	Core::Class	CompoundOperator		See Section 8.3.18
	CommonBehavior::Object			See Section 8.3.18
EAITimer	Core::Class	Timer	CompoundOperator	See Section 8.3.13
EAIRouter	Core::Class	Router	CompoundOperator	See Section 8.3.14
EAIPrimitiveOperator (and subclasses)	Core::Association, CommonBehavior::Object			See Section 8.3.18
EAICompoundOperator (and subclasses)	Core::Association, CommonBehavior::Object			See Section 8.3.18
EAIResource (and subclasses)	CommonBehavior::Object			See Section 8.3.18
EAITerminal (and subclasses)	CommonBehavior::Object			See Section 8.3.18
EAILink	CommonBehavior::Link			See Section 8.3.18

Mapping Constraints

EAICompoundOperator

24. This mapping is only valid for compound operators defining a type (not ones used to show connectivity of components).
25. The name of operator (and hence the type which the operator defines) is the name of the class.
26. There must be an association on the class diagram corresponding to each terminal of the compound operator.
27. On the class-diagram part of the definition of the compound operator, there must be an association for each component operator.
28. The object is unnamed on the collaboration diagram defining the connectivity of the compound's components, and it contains all objects corresponding to the component operators and their terminals.

29. On the collaboration diagram, the objects corresponding to the terminals of the operator appear outside the object corresponding to the operator.

EATimer and EAIRouter

30. Exceptionally, the components of these operators are not exposed in the profile. Therefore they do not have collaboration diagrams associated with them, and they do not map to objects.

EAIPrimitiveOperator (and subclasses), EAICompoundOperator (and subclasses).

31. This mapping is only valid for operators which are used in the role of defining the components of a compound operator. That is, they do not define a type, and they are owned by a compound operator (one of its nodes).
32. The association must be a composite association. The name of the part end corresponds to the name of the operator. The association is sourced on the class corresponding to the compound operator of which the operator in question is a part, and targeted on the class corresponding to the operator which defines the type of the operator in question.
33. The name of the object corresponds to the name of the operator. The type of the object is the class that corresponds to the operator which defines the type of the operator in question.
34. There must be an object corresponding to each terminal of the operator, and this must be linked to the object corresponding to the operator.
35. The object corresponding to the operator in question may be linked to an object corresponding to a resource, if the operator that defines the type of the operator in question is associated with a resource. The type of the resource object is the class corresponding to the resource.

EAIResource (and subclasses)

36. This mapping is only valid if the resource is associated with an operator used in the role of defining a component of a compound.

EAITerminal

37. The name of the object is the name of the terminal. The type of the object is the class corresponding to the terminal that defines the parameter associated with the terminal.

EAILink

38. The (UML) link must connect the objects associated with terminals that the (EAI) link connects.

39. The (UML) link has no message if the value of the synchronization attribute of the (EAI) link is unspecified. It has a synchronous (asynchronous) message if the value of that attribute is synchronous (asynchronous). The direction of the message is from the object corresponding to the source of the (EAI) link, to the object corresponding to the target of the (EAI) link.

8.6.3 Resources

Table 8-6 Mapping of resources

EAI Metaclass	Base class	Stereotype	Parent	Description & constraints
EAIResource	Core::Association			See Section 4.4
	Core::Class	Resource		See Section 4.4
EAIDatabase	Core:: Association		Resource	See Section 4.4
	Core::Class	Database	Resource	See Section 4.4
EAIQueue	Core:: Association		Resource	See Section 4.4
	Core::Class	Queue	Resource	See Section 4.4
EAISubscriptionTable	Core:: Association		Resource	See Section 4.4
	Core:: Class	SubscriptionTable	Resource	See Section 4.4

8.6.3.1 Mapping Constraints

40. The name of the resource maps to the name of the target end of the association.
41. The source of the association is the class corresponding to the operator associated with the resource.
42. The target of the association must be a class with a stereotype corresponding to the name of the (metamodel concrete) class of the resource.

8.6.4 Message Formats

EAI Metaclass	Base Class	Stereotype	Parent	Description & constraints
EAIMessageContent	Core::Class	MessageContent		See Section 4.5.1
EAIMessagePart	Core::Class	MessagePart		See Section 4.5.1
EAIComposedMessagePart	Core::Class	ComposedMessagePart	MessagePart	See Section 4.5.1
TDLangElement	Core::Class	LangElement		See Section 4.5.1
EAIHeader	Core::Class	MOMHeader	MessageElement	See Section 4.5.2
EAIExceptionNotice	Core::Class	ExceptionNotice	MessageContent	See Section 4.5.2

8.6.4.1 Mapping Constraints

TDLangElement

43. Composed types will map to a TDLangElement with a TDLangComposedType. See Section 7.3.8.4, “TDLangElement,” on page 7-21.

Messages are produced as a result of business events occurring in enterprise applications. The sequence of these events and the resulting message flows across system boundaries is defined in the overall system integration process. This section describes a profile for modeling EAI processes using activity graphs. These models can subsequently be refined to realize the functionality specified using the stereotypes defined in Chapter 8.

9.1 Modeling Integration Processes

Chapter 8 describes a profile for defining the collaborations necessary for application integration. It may be characterized as a profile for designing integrations. Many application-integration developers also adopt a process-oriented approach where the initial artifact is a definition of the business process, end-to-end, which is to be integrated. Of course such a process definition will encompass many integration points, each of which will need to be implemented. The value of the process view is to establish the requirement in a form that is understandable and verifiable by the business users. In this sense it is a requirements or analysis view and exists at a higher level of abstraction than the collaboration-based definitions of the previous chapter.

Whilst for any particular implementation approach it should be possible to map the analysis model onto the design model, it is beyond the scope of this specification to do so. In a sense, it would be pre-empting the development process. We consider a general formal mapping - with enforcement of a level of detail capable of formal mapping - to be inappropriate, since different practitioners have different approaches.

9.2 An Integration Process Scenario

Integration processes contain control flow and message flow aspects. Message flow is fundamental in EAI processes, as message-based integration is at the core of the problem domain.

This section introduces the profile elements required to define such models by means of an example scenario. Variants of the scenario are discussed. Some illustrate the capability of the profile to support high levels of abstraction, such as might be preferred for communicating with business users; others illustrate how the profile can be used to define more detail.

9.2.1 The Exchange Process

The scenario we have chosen is a collaborative business-to-business example, where Buyers and Sellers negotiate a transaction via an online Exchange. The overall process is represented in the activity graph in Figure 9-1. Annotations have been added (as parameters on transitions) to represent additional information about required operations (such as transformations) and to identify implementation details (such as queues). This is an example of where different practitioners might choose to capture this information at this level or may choose to omit it. The intention is that the profile is capable of representing it if required.

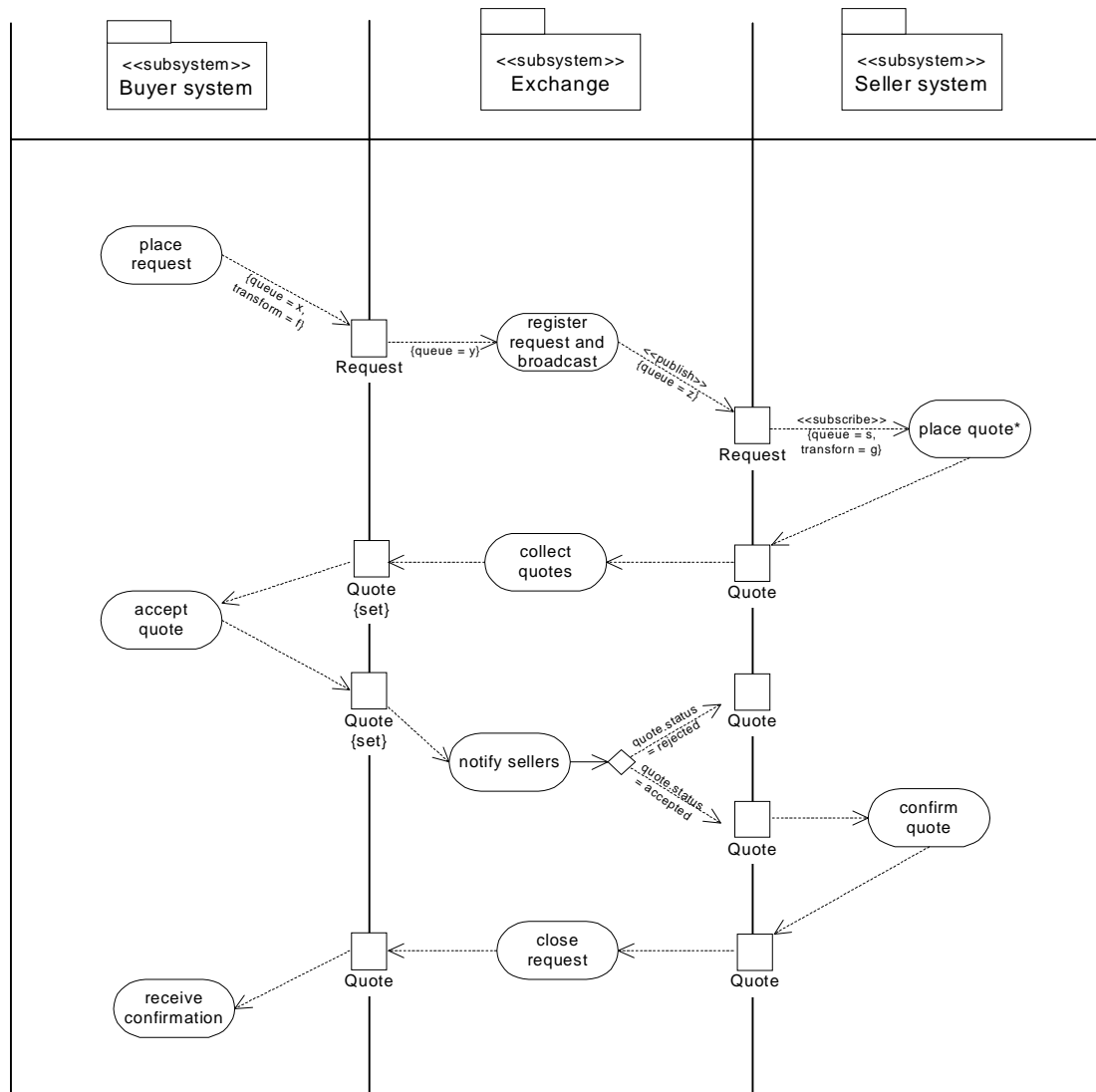

Figure 9-1 Basic way of modeling message based integration with Activities (Exchange example)

In this example, activities represent the legacy applications that consume and/or raise business events. The existence of connectors to detect and publish the events and to interpret these events for the legacy applications is implicit at this level of abstraction.

9.2.2 Modeling message flow explicitly

The message-flow aspects can be emphasized by using an explicit stereotype "messageFlow" for the transfer of messages between subsystems. This approach, illustrated in Figure 9-2, contrasts with the more abstract approach illustrated in Figure 9-1.

Note that the use of a transition between two ObjectFlowStates is not normal activity-graph usage, but is not prohibited by the UML semantics definitions.

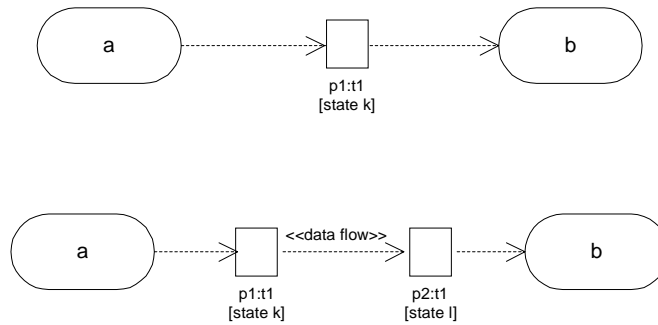

Figure 9-2 Application of the "messageFlow" stereotype to emphasize data-flow aspects

Figure 9-3 illustrates the impact of applying this technique to the exchange example.

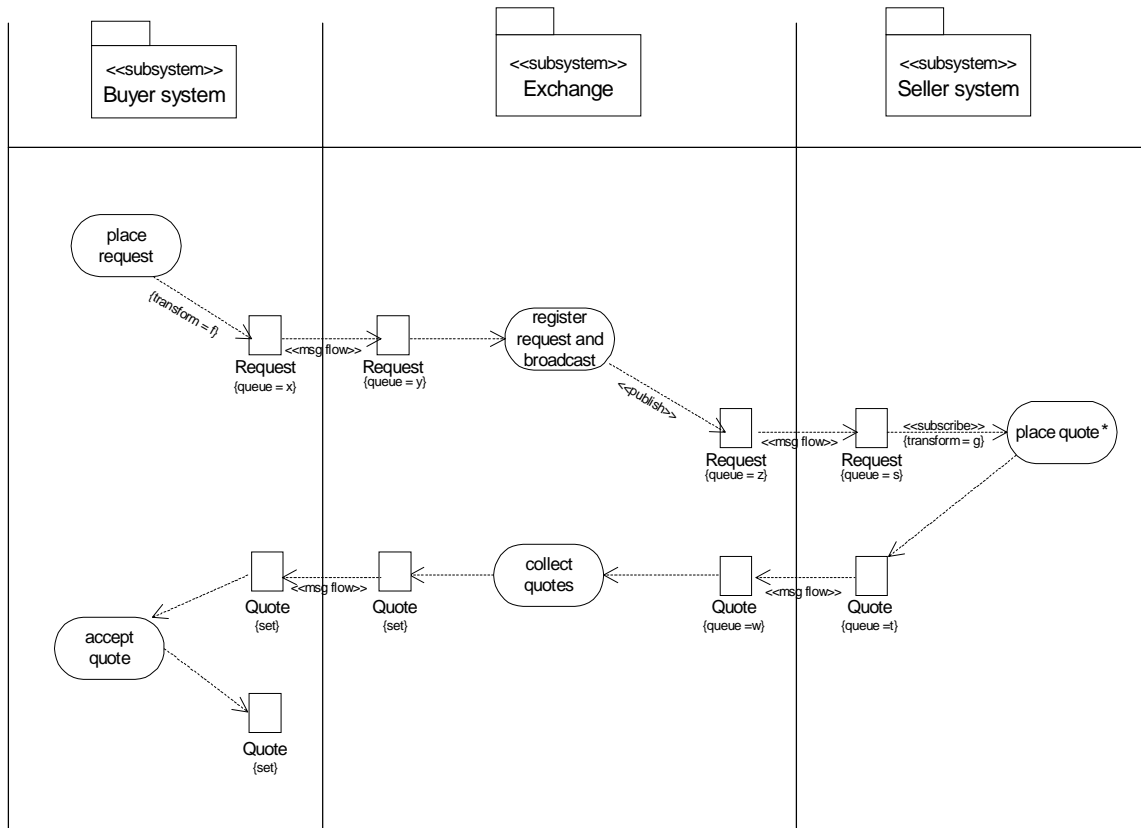

Figure 9-3 Application integration example with "messageflow" stereotype (partial)

In this activity graph, the partitions represent the enterprise systems that require integration. Inside each partition, action states (i.e., activities) represent the invocation of application APIs. A transition between an activity and an object-flow state represents the production or consumption of a message. Transitions with the stereotype "messageFlow" represent message transfers across system boundaries. Message flows may be "point-to-point." They may also be designated as "multicast" (according to a publish/subscribe protocol) by adding the stereotypes "publish" and "subscribe" to appropriate transitions.

9.2.3 Modeling control flow

In addition to message flow aspects, control flow aspects can be added to the process definition. In Figure 9-4, control flow transitions have been added within each of the component systems in a fragment of the Exchange example.

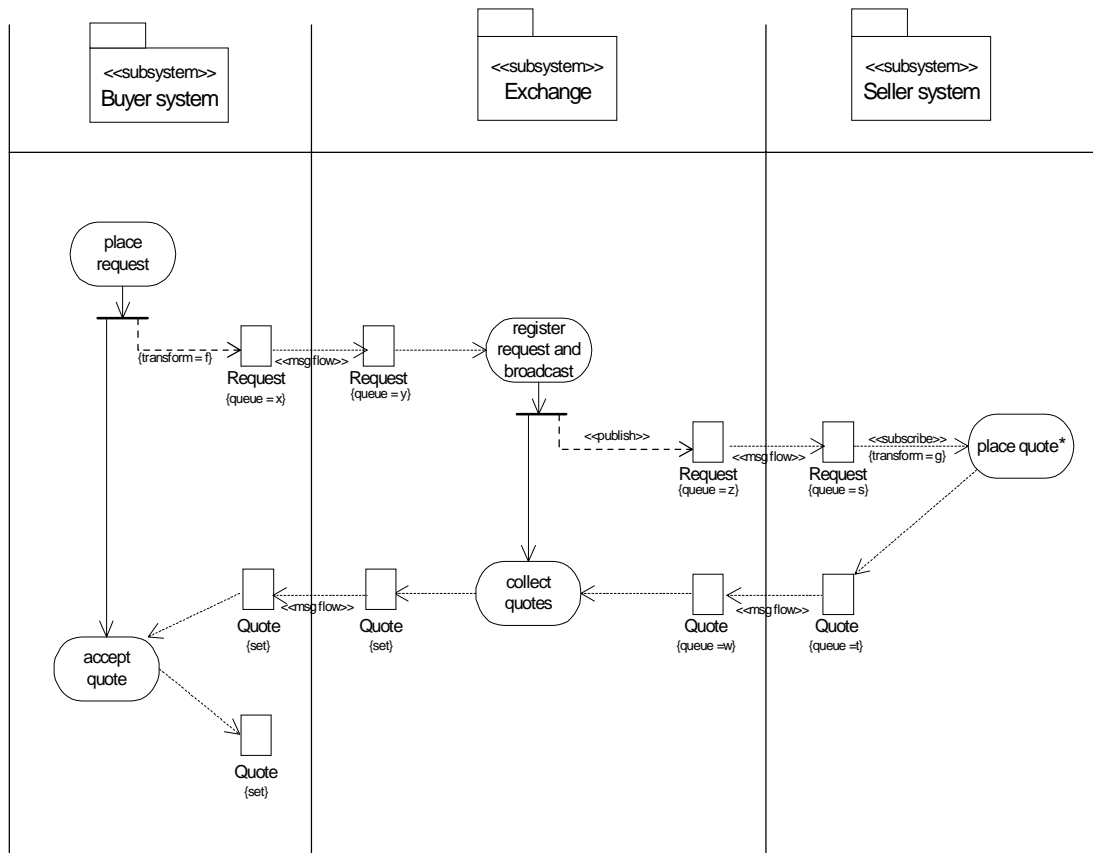

Figure 9-4 Optional control flow transitions between activities within a single system

9.2.4 Abstracting detail by decomposition

Activities can be decomposed to show the constituent set of subactivities. An example of the decomposition of the integration step "Place Quote" is shown in Figure 9-5. In this step, an incoming Request message results in an outgoing Quote message. In the decomposition, a "connector" activity is responsible for handling the incoming message. Once a message is accepted by the system, a "transformer" activity transforms the message content to a locally acceptable format. Finally, "adapter" activities take this known input and adapt it into the legacy data store format. A subsequent "adapter" is responsible for invoking the legacy system. After the legacy application has run, a similar set of steps produces the outgoing message.

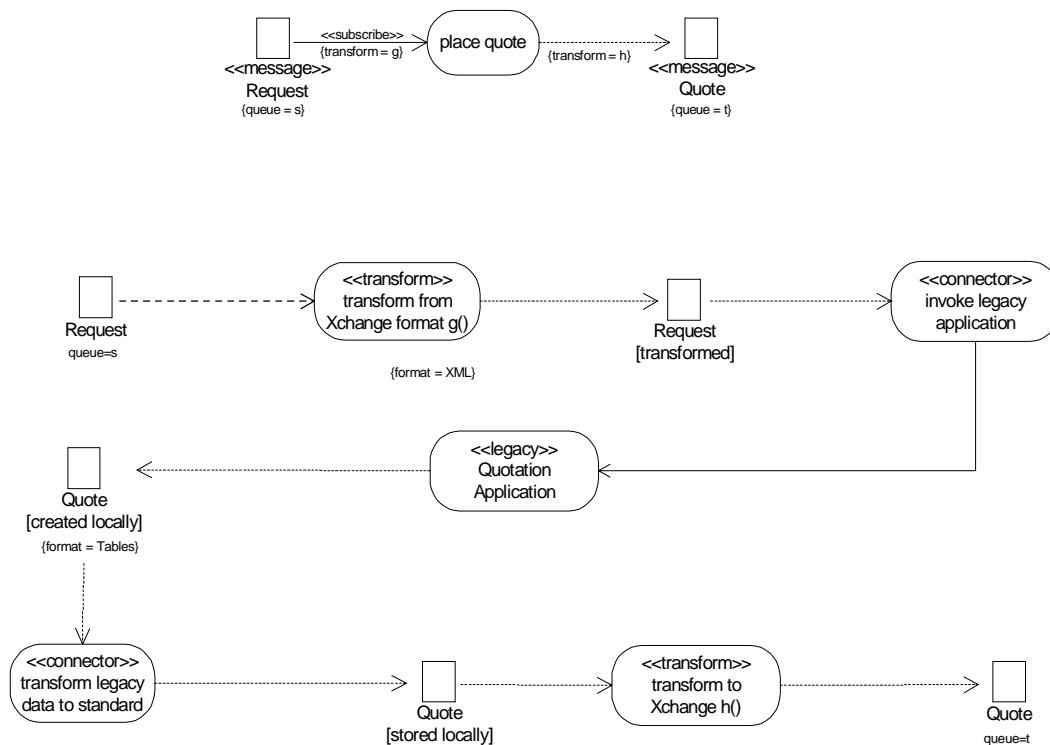

Figure 9-5 Decomposition of the integration step "Place Quote" in the context of the Exchange example

It should be noted that the above figure constitutes a prototypical example - many variants of these will exist using additional operator activities (e.g., involving "router" and "filter" operators) and with varying process structure.

9.2.5 Further fragmentary examples

Other activity graph constructions that can be used in modeling system-integration processes are described in the following subsections.

9.2.5.1 Multiple synchronized inputs and outputs

Multiple synchronized inputs and/or outputs can be modeled with join and fork pseudo-states (see Figure 9-6).

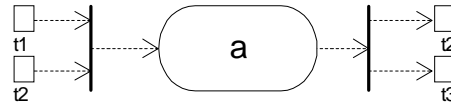

Figure 9-6 Modeling multiple inputs and outputs with join and fork pseudo-states.

9.2.5.2 Internal dataflows within a subsystem

An internal dataflow between two activities within a single system can be modeled with ObjectFlowStates (see Figure 9-7).

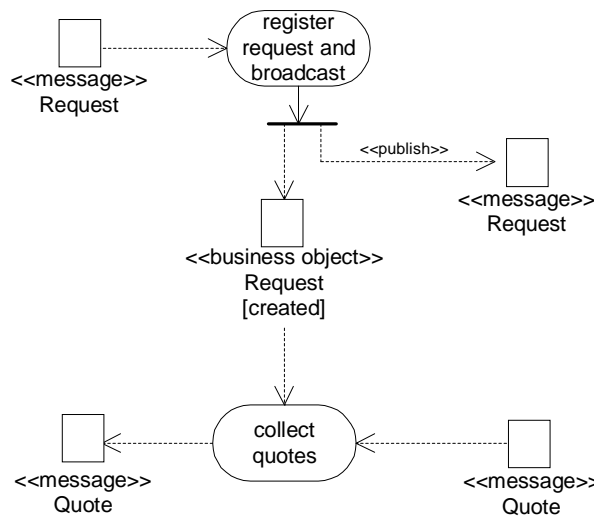

Figure 9-7 Modeling internal data flow with object flow states

9.2.5.3 Modeling decisions explicitly

Decisions can be modeled with guards, either implicitly with multiple outgoing or explicitly by using a decision PseudoState - the latter approach is relevant for modeling content based routing where the middleware is responsible for rule execution (as opposed to embedded rules executed by applications) (see Figure 9-8).

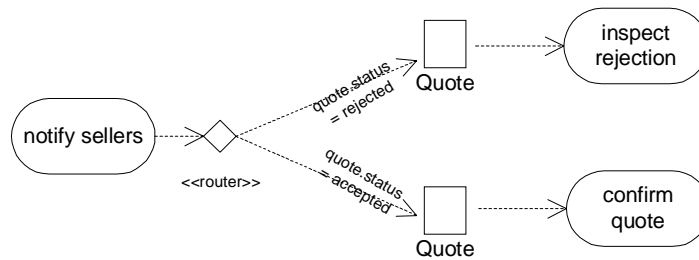

Figure 9-8 Example of a decision node to model rule-based routing

9.2.5.4 Synchronization

Synchronization is made explicit with Fork and Join PseudoStates - for instance, this can be used to model multiple parallel invocation of legacy systems in the case that there is more than one system (or more than one function) needing to be invoked (see Figure 9-9).

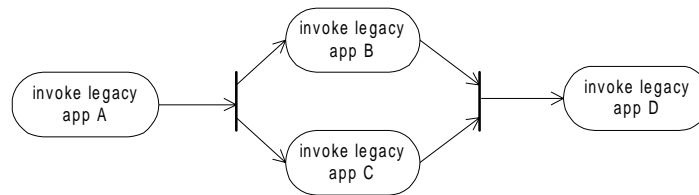

Figure 9-9 Synchronization with forks and joins

9.2.5.5 Multiple concurrent invocations of activities

Dynamic concurrent invocation of activities (where the number of actual activities invoked is determined at run time depending on the input) is denoted by a "*" symbol in the activity (see Figure 9-10).

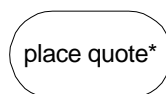

Figure 9-10 Dynamic concurrent invocation of an activity

9.2.5.6 Modeling business events explicitly

Events (as based on the definition of a signal in UML) can be added to transitions or they can be modeled explicitly as object-flow states. In the latter case, the underlying classifier is a signal, with attributes representing the event parameters. This can be

useful for modeling "adapter" implementations that respond to events (e.g., a database trigger) and for systems that natively expose a required integration event on their interface (see Figure 9-11).

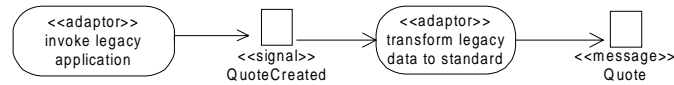

Figure 9-11 Explicit modeling of an event for an adapter implementation

Integration processes will usually not be defined beyond this level of detail in activity graphs. The design of the interactions between the classes involved is best described using collaboration modeling, as discussed in *Collaboration Modeling* chapter 8.

9.3 Profile Element Summary

The following is a summary of the activity-graph stereotypes and tagged values for modeling processes in the context of EAI. These stereotypes are in addition to the ones defined in Chapter 4. Tagged values on the activity stereotypes enable the linking of activities to their realization in terms of the Operator and Message Classifiers that implement the messaging functionality at the Collaboration level.

It should be noted that some stereotypes apply to more than one UML metaclass. In some cases, the metaclass name is given in brackets to indicate that this is a secondary modeling option. For instance, a "transform" stereotype is primarily attached to an activity, indicating that the activity is realized by a transform operator. A "transform" stereotype can also be attached to a transition as a secondary option which can be useful for models that are (to be) decomposed.

This profile definition assumes the UML 1.3 extension mechanism, which is string-based. In UML 1.4, references to metaclasses can be used as an alternative to name based strings. Furthermore, in UML 1.4, multiple stereotypes can be applied to an element.

9.3.1 Stereotypes

Table 9-1 defines the basic stereotypes. Tagged values for these stereotypes are defined in Table 9-2.

Table 9-1 Behavior stereotypes for modeling EAI system-integration processes

Stereotype	UML metaclass	Comments / constraints
"integration process	"ActivityGraph	A system integration process in the context of EAI
"message	"ObjectFlowState	A data element that is interchanged between two systems. The ObjectFlowState "inherits" the stereotype from the Signal classifier with stereotype "message" that it points to, if one is defined at this stage (tagged value defined below). The underlying Classifier of the ObjectFlowState represents the "content" of the message (to be added as a Signal parameter during design). The production or consumption of a message by an activity is modeled with a "flow" Transition
"flow	"Transition	A flow is an exchange of data between two systems. An abstract stereotype. A "flow" may optionally have an associated guard condition
"messageflow	"Transition	A "messageflow" is a subtype of a "flow" where the Transition is to or from a "message". Abbreviated to "msg flow". The production or consumption of a message constitutes an event in EAI context. Note that general business events are modeled as Signals in UML.
"connector	"ActionState, ActivityGraph(Transition)	A "connector" is a simple or compound activity that converts a specific kind of message from some system-specific format into a specified message-content type, or vice versa
"operator	"ActionState, ActivityGraph(Transition)	An "operator" is an activity that acts upon messages as they flow between systems. Note: if the activity has more than one message as input or output, then the operator must be a Compound Operator.
"transform	"ActionState, ActivityGraph,(Transition)	A kind of operator that transforms datasets from one format to another. An instantiable subtype stereotype of "operator"
"filter	"ActionState, ActivityGraph,(Transition)	A kind of operator that filters messages according to a rule
"router	"ActionState, ActivityGraph(PseudoState)	A kind of operator that determines a outgoing channel based on a rule
"stream	"ActionState, ActivityGraph(Transition)	A kind of operator
"adapter	"ActionState, ActivityGraph(Transition)	A kind of operator, indicating a wrapper activity that that encapsulates dataflow and / or controlflow to and from a legacy system, e.g. an operator that performs invocation and associated marshalling.
"publish	"Transition(ActionState)	A kind of operator, indicating that there is a publisher - subscriber protocol involved in the message transmission (default is point - to - point)
"subscribe	"Transition(ActionState)	A kind of operator, indicating that there is a publisher - subscriber protocol involved in the message transmission (default is point - to - point)
"legacy	"ActionState, ActivityGraph(PseudoState)	A "legacy" is any existing application that participates in an integration

9.3.2 Tagged Values

Table 9-2 defines the extended "meta-properties" (i.e., tagged values) for the stereotypes defined above, and a number of general supporting tags. Some of these tags are references to classes and signals that are defined using the modeling framework defined in Chapter 4. These references define the realization of the messaging functionality specified in the integration process (e.g., using sequence diagrams).

Table 9-2 Tagged values with the stereotypes defined in the previous table

Tagged value	UML Metaclass / stereotype	Notes
signalImplementation : String	"message" ObjectFlowState	Indicates that an ObjectFlowState with stereotype "message" is realized by a Signal (note: in UML 1.4 this becomes a reference to a Signal Classifier stereotyped "message" instead of a string). Note the base classifier reference of the ObjectFlowState points to its content class.
sourceImplementation : String	"message" ObjectFlowState (ActionState,ActivityGraph)	Indicates that an ObjectFlowState with stereotype "message" is realized as a Source Classifier at a detailed level (note: in UML 1.4 this becomes a reference to a Classifier instead of a string). Alternatively, when applied to an activity it indicates that in the detailed realization this activity has an associated Source Classifier. Optional property.
targetImplementation : String	"message" ObjectFlowState (ActionState,ActivityGraph)	Indicates that an ObjectFlowState with stereotype "message" is realized as a Target Classifier at a detailed level (note: in UML 1.4 this becomes a reference to a Classifier instead of a string). Alternatively, when applied to an activity it indicates that in the detailed realization this activity has an associated Target Classifier. Optional property.
queueName : String	"message" ObjectFlowState(Transition)	Indicates the name of the queue to be used (note: in UML 1.4 this becomes a reference to a Queue Classifier instead of a string)
queueProtocol : String {JMS, IBM MQ, Oracle AQ, ...}	"message" ObjectFlowState (Transition)	Indicates the target implementation type for the queue
format : String {XML, ...}	"message" ObjectFlowState (Transition)	Indicates the target implementation format for the message
isSet : Boolean	"message" ObjectFlowState	Indicates that an ObjectFlowState contains a set of messages. Shorthand notation for a type expression, e.g., "Set of Quote".
communicationProtocol : String {http, iiop, smtp, ...}	Transition	Indicates the target communication protocol to be used

Table 9-2 Tagged values with the stereotypes defined in the previous table

Tagged value	UML Metaclass / stereotype	Notes
operatorImplementation : String	"operator" Activity (Transition)	Indicates a reference to the Classifier that realizes the activity. Note: in the case of a subtype of "operator" such as "transform", "connector", "publish" or "adapter" this tagged value indicates the transformationImplementation Classifier, connectorImplementation Classifier, etc. (note: in UML 1.4 this becomes a reference to a Classifier with stereotype "operator" instead of a string)
operationImplementation : String	"adapter" Activity (Transition)	Indicates a reference to a public operation of a "legacy" system (note: in UML 1.4 this becomes a reference to an Operation on a Classifier instead of a string)
directoryNameEntry : String	Subsystem	Indicates the implementation target name for the subsystem

9.3.3 Mapping to EAI Metamodel

Although the activity graph elements are largely used at a higher level of abstraction, as illustrated above, it is possible to decompose some aspects of the model sufficiently to map directly onto the same metaobjects as the collaboration model. Table 9-3 lists these mappings and identifies the appropriate metaclasses to map the other activity graph profile elements.

Table 9-3 Mapping from Activity Graph Stereotypes to EAI Metaclasses

Stereotype	EAI metaclass	Comments/Constraints
"integration process"	"FCMComposition"	The "integration process" is the overall context for the model. It is merely the aggregation of all the elements of the activity graph.
"message"	"EAIMessageContent"	Direct mapping
"flow"	"FCMLink"	Not being constrained to only connecting terminals, a "flow" in the activity graph profile, which is a stereotype on the UML metaclass Transition, is more generic than EAILink
"messageflow"	"FCMDataLink"	A "messageflow" is an example of a Transition that does not directly connect Terminals. It represents the propagation of a message from one system to another, probably implemented as queue-to-queue propagation, but at this level of abstraction it is not appropriate to specify that.
"connector"	"EAIPrimitiveOperator"	Direct mapping
"operator"	"EAIPrimitiveOperator"	Direct mapping
"transform"	"EAITransformer"	Direct mapping
"filter"	"EAIFilter"	Direct mapping
"router"	"EAIRouter"	Direct mapping
"stream"	"EAIStream"	Direct mapping

Table 9-3 Mapping from Activity Graph Stereotypes to EAI Metaclasses

Stereotype	EAI metaclass	Comments/Constraints
"adapter	"EAISourceAdapter/EAITargetAdapter	Whether an instance of an activity model "adapter" is an instance of an EAISourceAdapter or an EAITargetAdapter can be inferred from the context.
"publish	"FCMLink	The application of this stereotype is specifying a constraint on the underlying queue implementation, but the link itself is not the queue. This is an example of where the analysis model contains a design hint but is not of itself a design specification.
"subscribe	"FCMLink	See "publish"
"legacy	"FCMNode	"legacy" is a necessary component of the activity profile because it provides a reference point for the business, but in the integration itself "legacy" has no behavior, so it is mapped to the generic FCMNode.

Part 4- Proof of Concept

Contents

This section contains the following chapters.

Section	Page
10. Example: Connectivity and Information Sharing	10-1
11. Example Using the EDOC CCA	11-1

This section provides a proof of concept for the profile by giving examples of the use of the profile for actual EAI modeling. An example is provided that is relevant to both of the scenarios of the Scope that are covered by this specification and uses collaboration modeling. In Chapter 11, a variant of part of this example is presented in the CCA of the UML Profile for EDOC.

Example: Connectivity and Information Sharing

10

This chapter shows how the UML Profile for EAI can be used to model the integration of applications for a brokerage firm using collaboration modeling. The chapter is structured as follows:

- Section 10.1 provides a brief description of what a brokerage firm does. This provides some explanation of the domain in which the models are being developed.
- The following sections describe aspects of the brokerage firm's systems, which are then captured in models expressed using the collaboration profile of Chapter 8.

10.1 The Brokerage Business

A brokerage firm accepts orders for stock trades from various parties:

- Direct from customers
- From partner brokerages in other countries
- From investment managers

The job of the brokerage firm is, essentially, to enact the trades requested in those orders and then send notifications back to the customer.

The focus of the modeling in this chapter is the handling of orders from partner brokerages and from investment managers. This requires an architecture integrating with the systems used by these stakeholders, which allows order events from systems external to the enterprise to be transformed into a common format and then filtered, elaborated and processed. Notifications need to be generated and sent back to the originating systems.

The overall architecture for this integration is depicted in Figure 10-1.

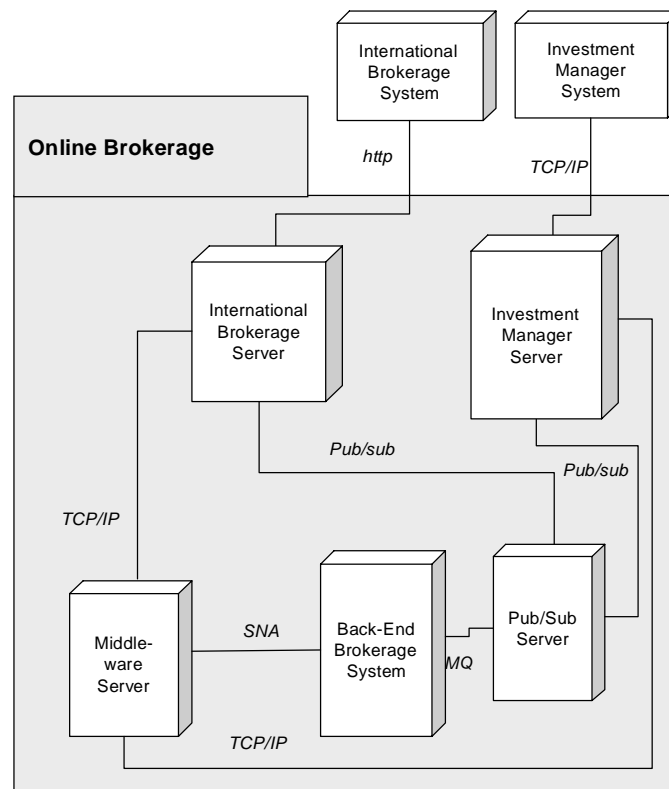

Figure 10-1 As-is architecture for international and investment managers

International customers (i.e., customers outside the U.S.) are served by a brokerage system in their own country. This system keeps track of portfolios for its customers. If those customers wish to trade U.S. securities, those trade requests are serviced by the on-line brokerage system.

Investment managers manage portfolios on behalf of customers with large or complex holdings. They use the brokerage system to place trades and to get information about various securities for their customers. Different investment-manager firms use different software for portfolio management.

Using the UML profile, we elaborate a model of the architecture of this system.

10.2 Connection of Enterprises to the Online Brokerage System

The on-line brokerage system is connected to five external systems. This is shown in the collaboration diagram in Figure 10-2.

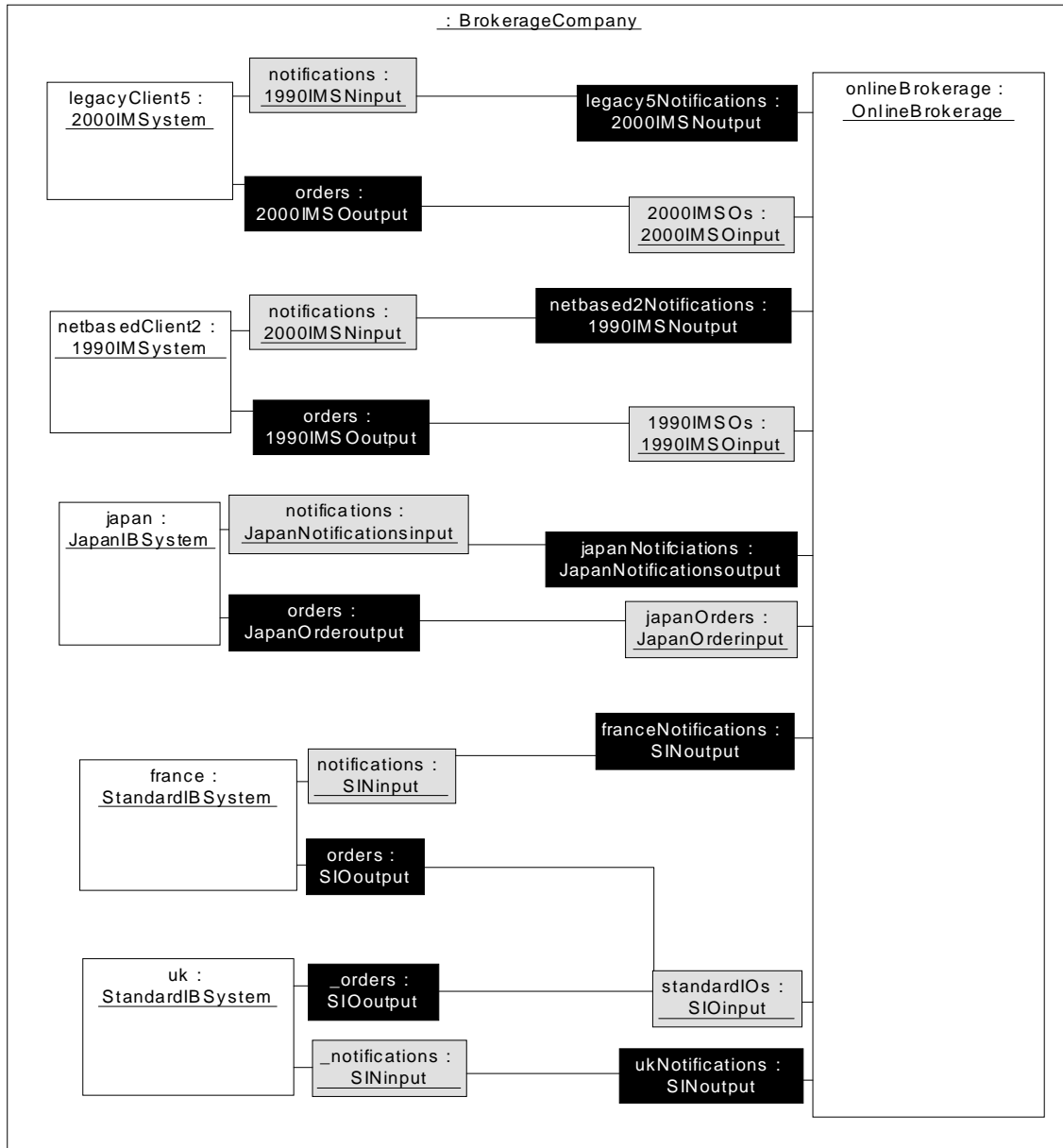

Figure 10-2 Brokerage company - component connections

This diagram highlights the two key processes involved:

1. The processing of orders entered into the system
2. The publication of notifications about processed orders

Thus each system external to the online brokerage has an output terminal for issuing orders to be sent on to the online brokerage system and an input terminal for receiving notifications back. Interestingly, although input streams of orders in the same format may be merged (e.g., the output terminals of uk and france both connect to the same input terminal of the on-line brokerage), the output streams of notifications will not. There are good business reasons (such as confidentiality) to ensure, for example, that only notifications for France go to France and not to also to the UK.

It has been left unspecified as to whether the connections between external systems and the on-line brokerage are synchronous or asynchronous, although they are likely to be asynchronous.

Figure 10-3 is the corresponding class diagram, which declares the components of the brokerage-company operator, where primitive operators are used to model the systems external to the online brokerage. Notice that two of the external systems (uk and france) are of the same type. The components of the compound operator representing the on-line brokerage system will be explored in the subsequent sections.

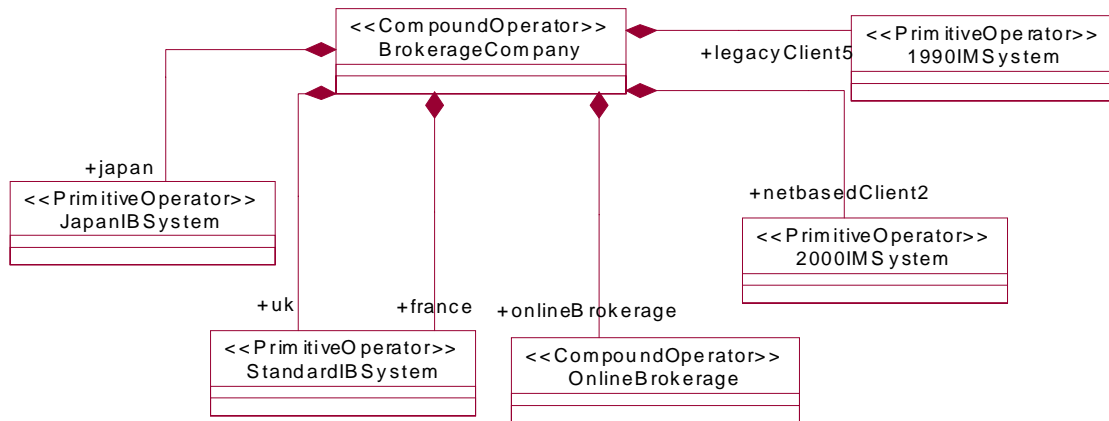

Figure 10-3 Brokerage company - components

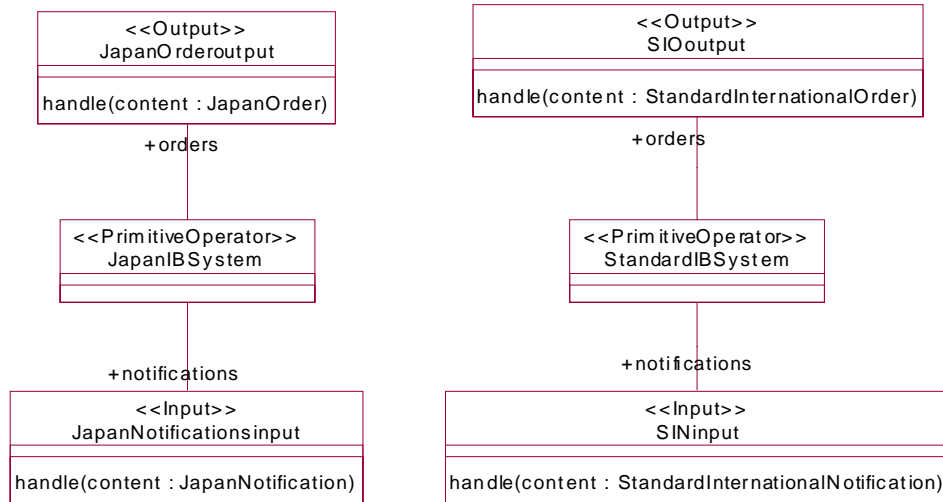

Figure 10-4 International brokerage systems - terminals

Figure 10-4 to Figure 10-6 define the terminals of all these operators and of the on-line brokerage. The on-line brokerage must handle four different formats of orders and notifications. Two of the systems (france and uk) use the same formats.

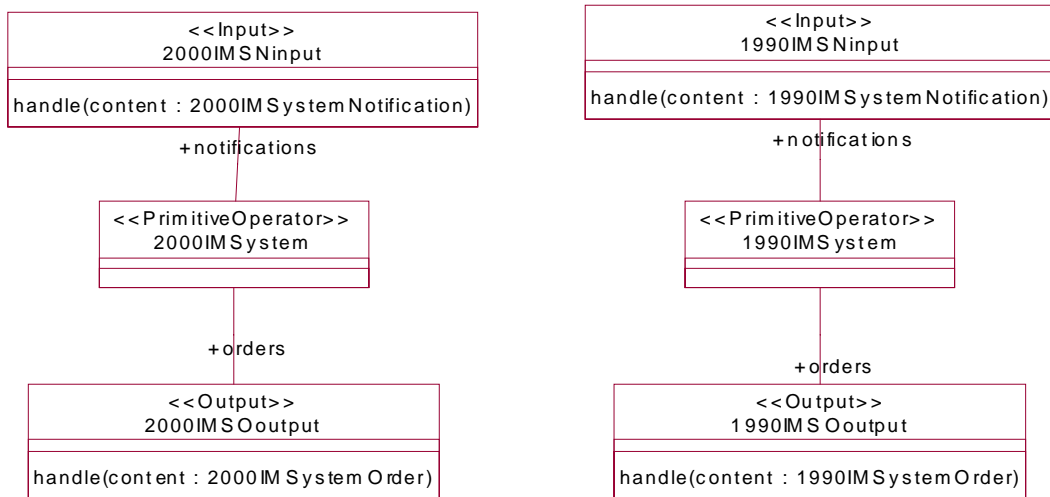

Figure 10-5 Investment-manager systems - terminals

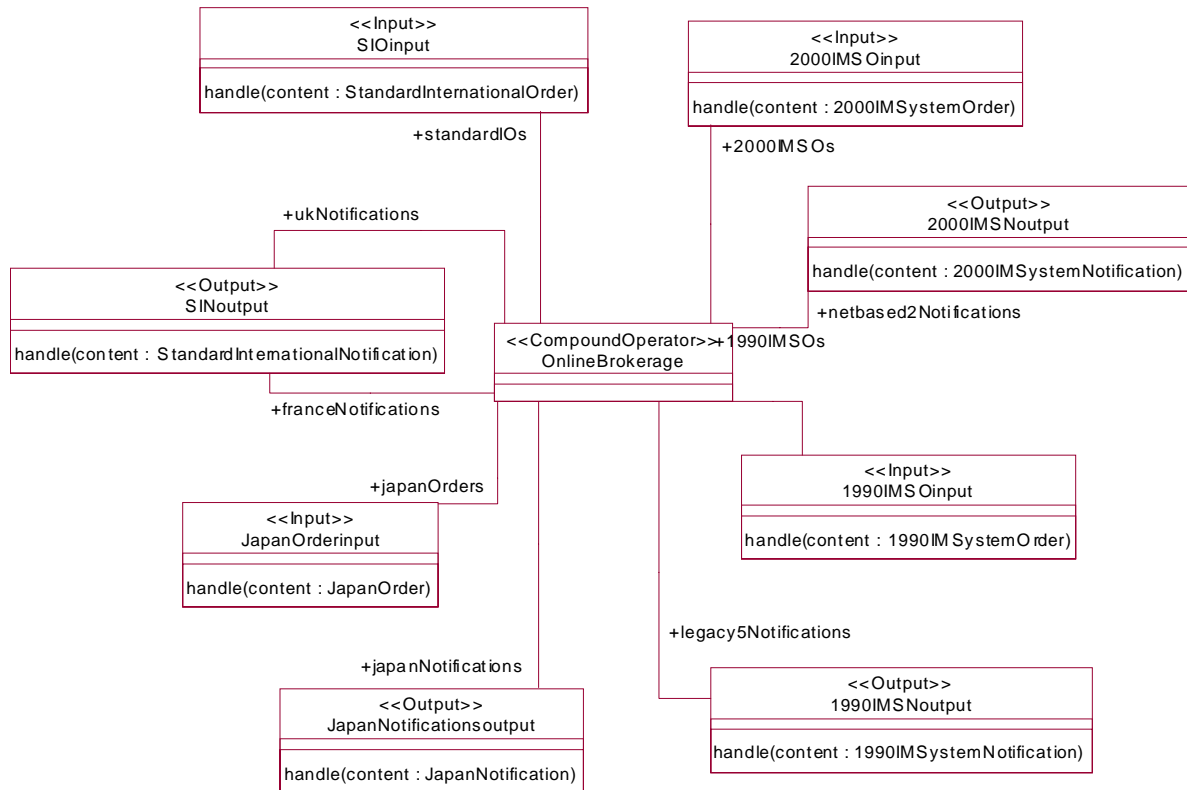

Figure 10-6 On-line brokerage system - terminals

10.3 The On-line Brokerage System

The on-line brokerage system is a compound of an international brokerage server, an investment manager server, a middleware server, a back-end brokerage system and a Pub/Sub server. The components are declared in Figure 10-7, and the way in which they are connected together is specified in Figure 10-8.

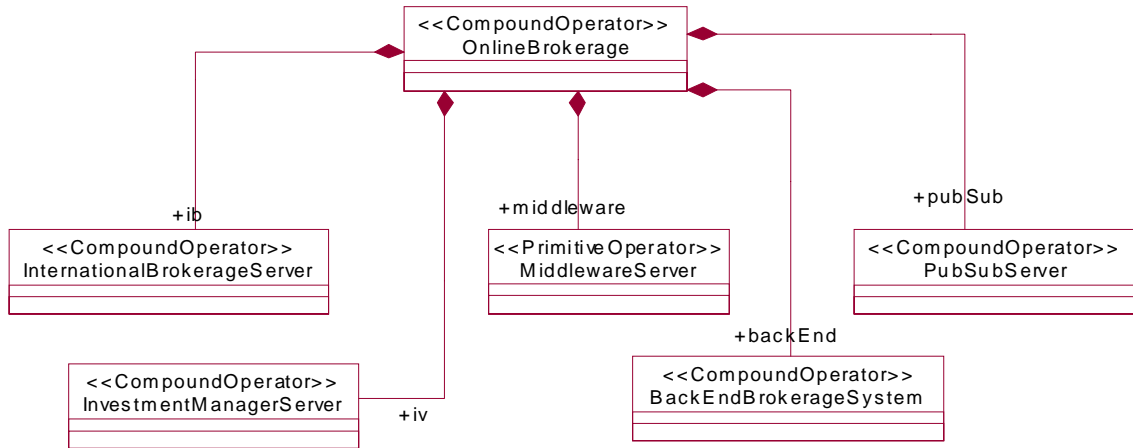

Figure 10-7 On-line brokerage system - components

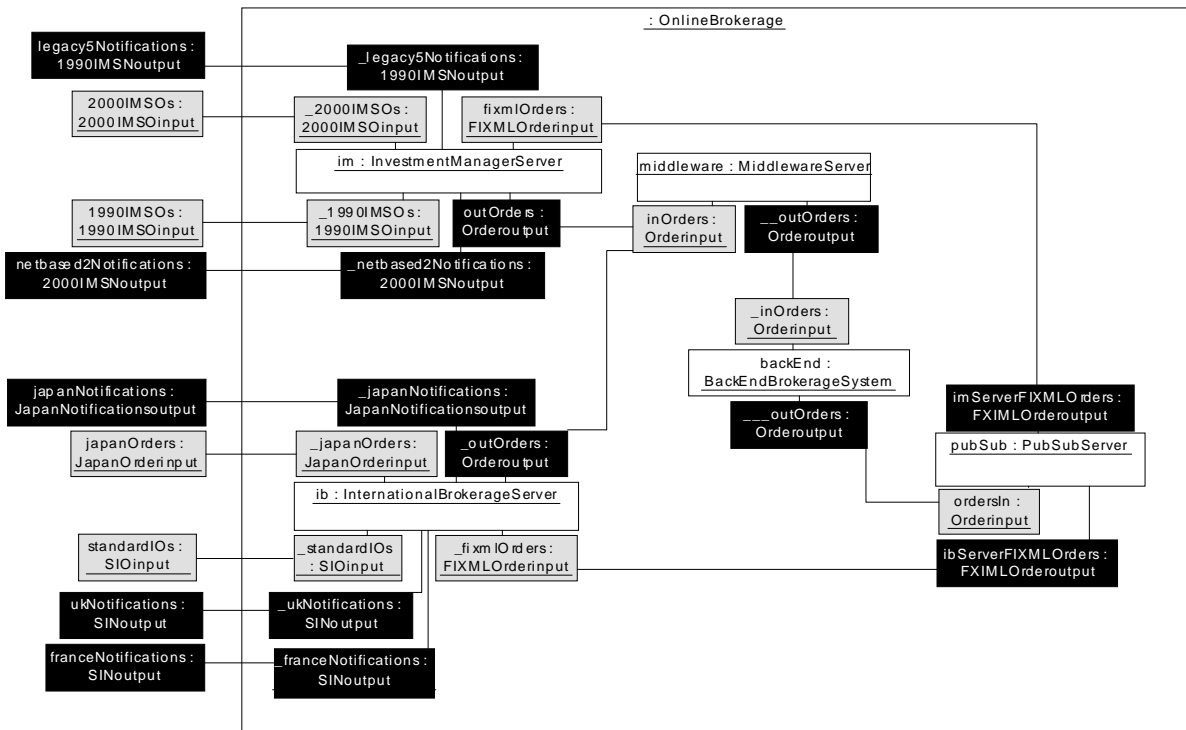

Figure 10-8 On-line brokerage - component connections

Orders from international brokers are handled by the international-brokerage server, and orders from the investment managers are handled by the investment-manager server. These systems convert the orders into a common format and pass them on to the middleware server, which forwards them to the back-end brokerage server. There the orders are processed, and ownership information is added. On exit from this system they are passed to the Pub/Sub server, which routes the processed orders back to the IB or IM system, depending on which one generated the order. The IB and IM systems generate notifications from the processed orders, which are passed on to the external systems as appropriate.

The terminals for each of these systems are defined by Figure 10-9 through to Figure 10-13. As usual, these diagrams give details about the formats of message handled by the terminals of each system.

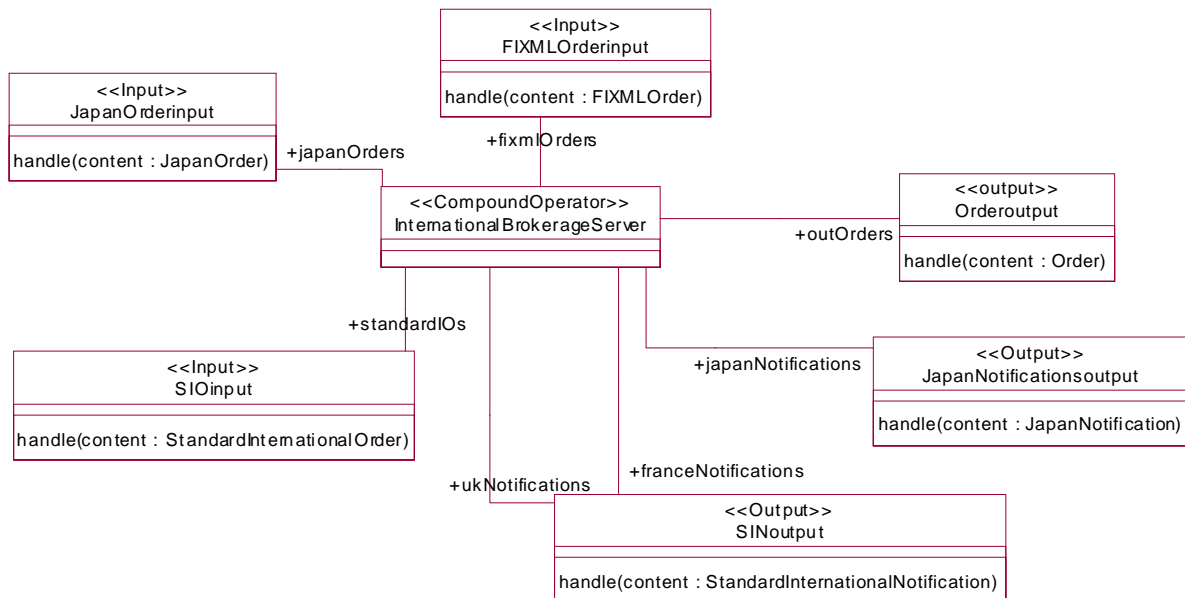

Figure 10-9 International brokerage server - terminals

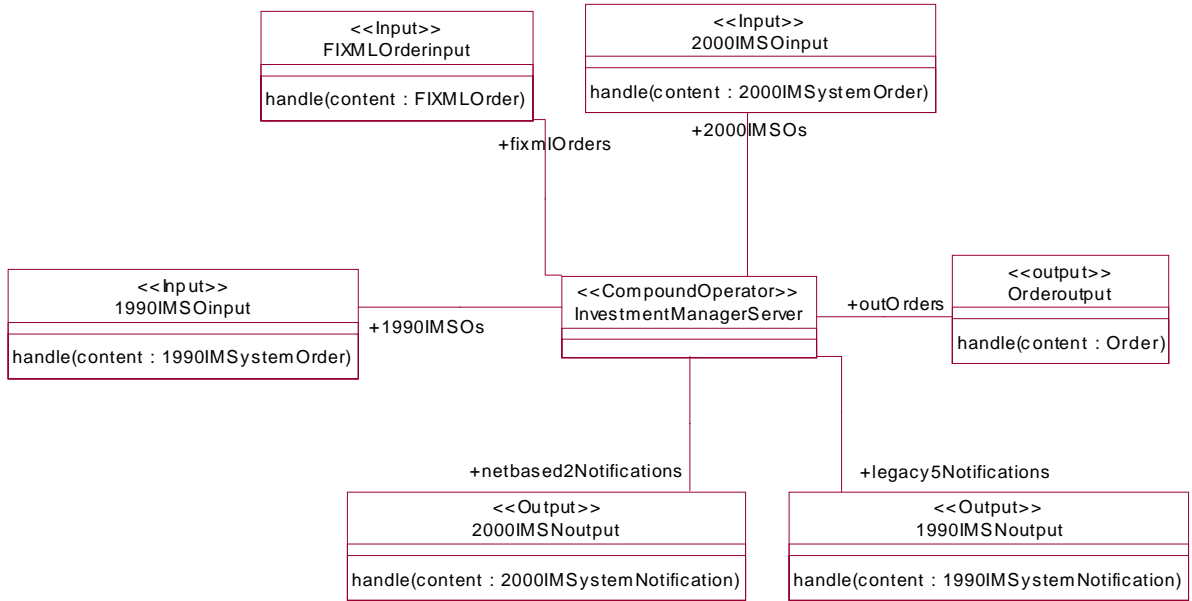

Figure 10-10 Investment-manager server - terminals

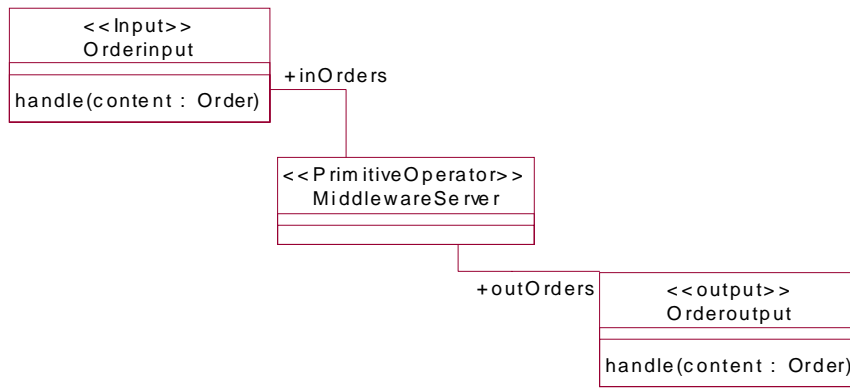

Figure 10-11 Middleware server - terminals

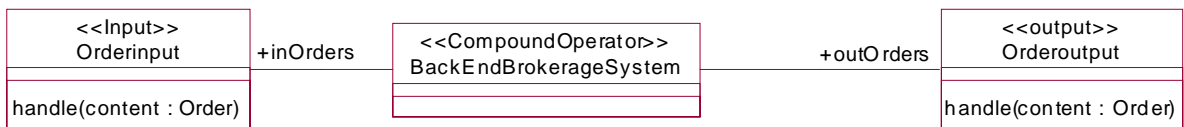

Figure 10-12 Back-end brokerage system - terminals



Figure 10-13 Pub/sub server - terminals

We are now ready to examine the workings of each of the components of the online brokerage server.

10.4 International Brokerage Server

10.4.1 Orders

For international customers, order flow is as follows:

- When a customer of an international broker places an order for execution of a trade involving securities traded on a U.S. exchange, the order is forwarded to the on-line brokerage for execution, which then passes on the order to its international brokerage server.
- The international brokerage server transforms the order into the standard format understood by the back-end systems.

10.4.2 Notifications

The International server will send notifications to the international broker in near real time. These are generated from the order events received from the Pub/Sub server.

The diagrams defining the components of the international-brokerage server (IBS) are given by Figure 10-14 and Figure 10-15.

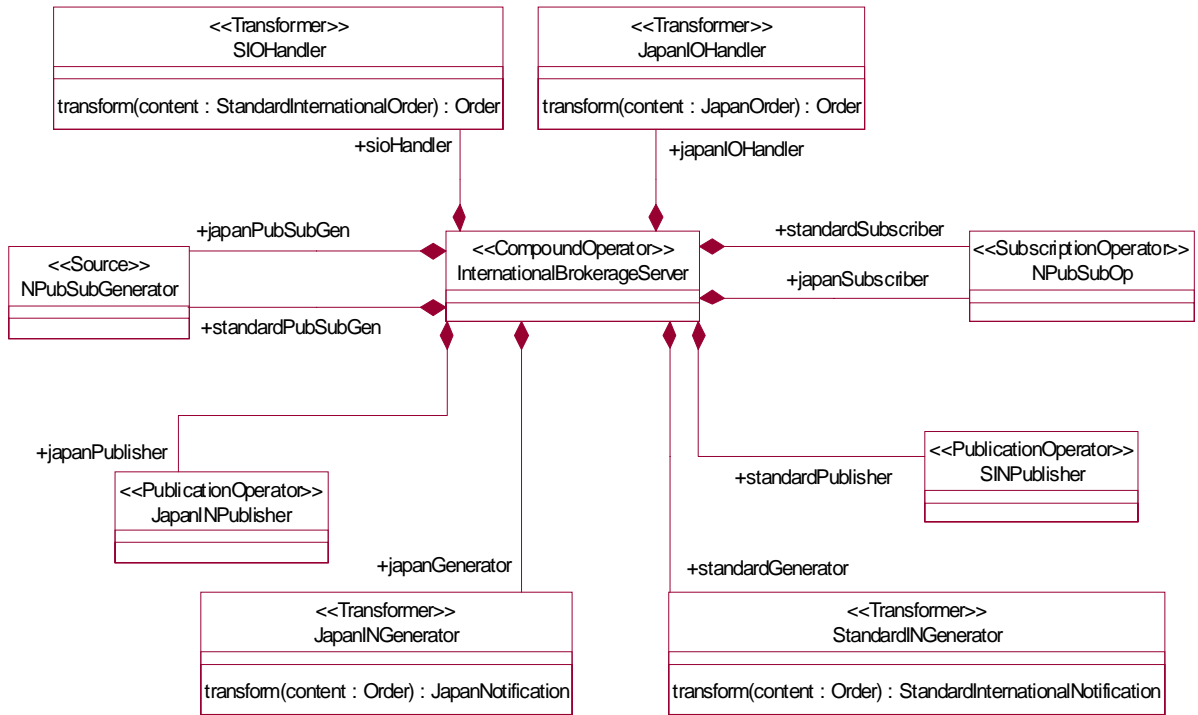

Figure 10-14 IBS - components

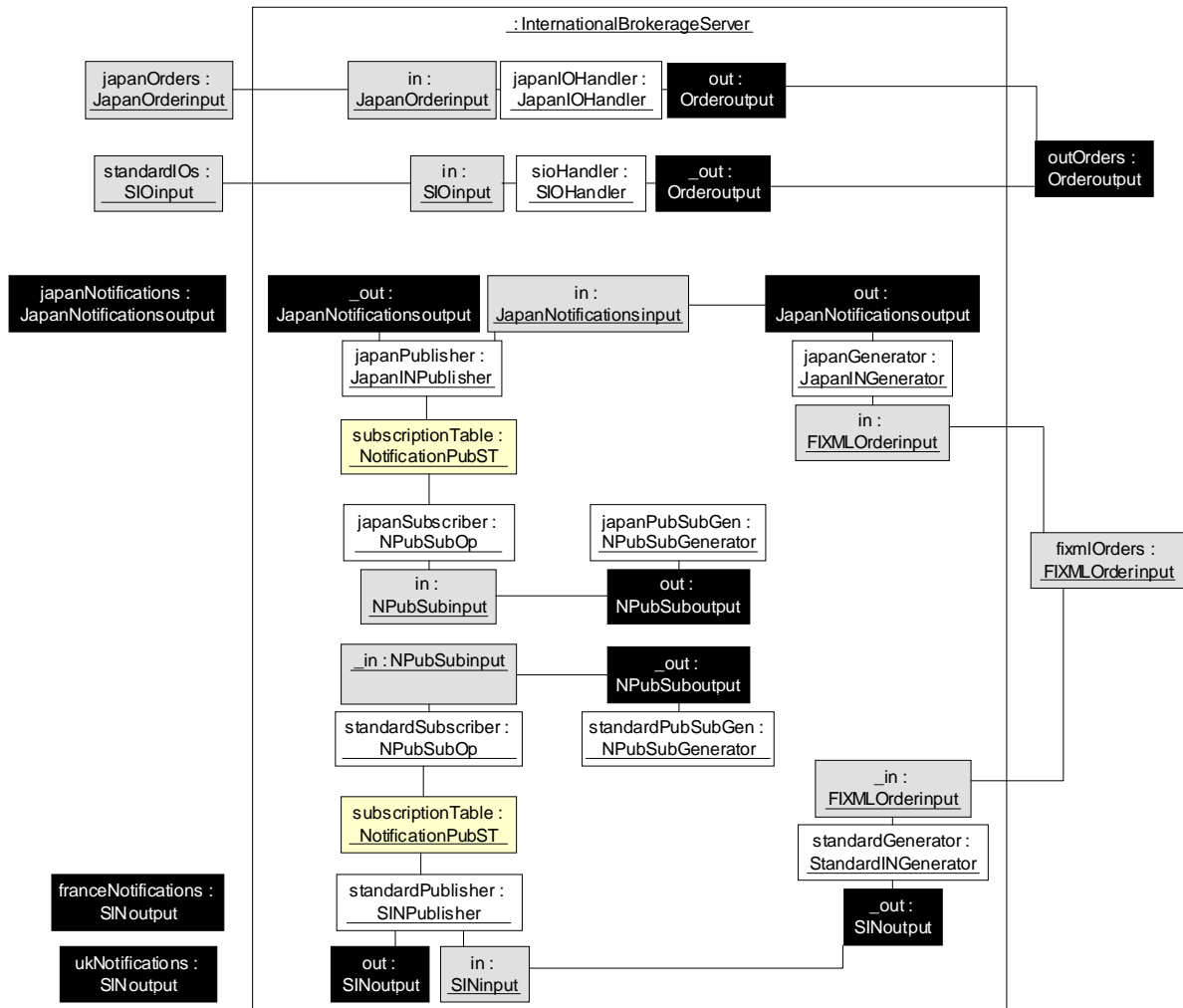

Figure 10-15 IBS - component connections

For orders, there needs to be one transformer per input format, which converts that input format to the standard format.

For notifications, there needs to be one transformer per notification format. As there may be many external systems which handle the same format (in this case uk and france work with the same format), and these are likely to come and go, it makes sense to use a dynamically configurable publication operator on the output of each transformer. This avoids having a separate transformer for each system; a transformer is only needed for to each format. This means, in turn, that connection of a new

system to Pub/Sub will only require a notification output terminal to be set up for connection to the notification input terminal of that system. New internal components will not be required.

The publication operator will dynamically connect to the appropriate notification output terminals on a message-by-message basis, as dictated by its subscription table. This explains why the notification output terminals of the IBS are not connected to any of its components. For each publisher, a combination of a subscription operator and source is used to generate subscriptions from some underlying system.

The definitions of the terminals of the components have been omitted, as they are relatively straightforward.

10.5 *Investment Manager Server*

10.5.1 *Orders*

Things are a little bit different for order placement from the Investment Manager systems:

- First of all, these systems utilize different tools for placing orders. So the Investment Manager server has to convert these different formats into a common format that can be handled by the middleware server and the back-end systems.
- Secondly, the investment managers commonly perform complex operations like balancing portfolios for a number of their customers at one time. This means sending a single message that can include multiple buy and sell orders for a single account and can include transactions on behalf of multiple accounts at the same time. It makes sense to think of all the transactions related to a single account as a unit of work in this context. The Investment Manager Server decomposes these complex messages and turns them into single order requests that are placed with the back-end systems.

Thus the handling of orders by the investment manager server is similar to that of the international brokerage server. The only difference is that the transformers generate batch orders in a standard format, and these then feed into a transformer, which takes a single batch order as input and generates multiple output messages in the standard order format.

10.5.2 *Notifications*

As with orders, the investment management server may batch up any number of notifications for transmission to its partners.

The modeling of the investment manager server, with respect to notifications, is similar to that of the international brokerage server. The only difference is that there must be an aggregator which generates batch orders from the order stream. They can then be fed on to the transformers and publishers.

10.6 Middleware Server and Back-End Brokerage System

Orders for international and investment customers go through the standard path for the brokerage system. They are routed to the middleware server, which forwards them to the back-end systems for execution. No additional modeling for the middleware server is required at this level.

The back-end brokerage system is responsible for processing the orders. As orders are processed and the order database is updated, this triggers events that mark changes in the state of the order to be published. At this point, the following things happen:

- The order is checked for "account ownership." Accounts belong to different organizations within the enterprise. In particular, the order events are examined at this point to determine whether or not the account belongs to the international or to the investment manager system. To make the determination requires extracting information from the customer databases.
- A further filter is then checked based on the type of order event. Not all order events are published from this back-end system.
- If the filter is passed, then a transformation is made of a database record into a COBOL copybook format. The information about account ownership is added to the order event.

The processing of orders is modeled by a primitive operator, which here has been called orderProcessor and is of type BackEndProcessingSystem. The other three stages of order manipulation are modeled by two filters and a transformer. These are declared in Figure 10-16, and the way in which they are connected together is specified by Figure 10-17.

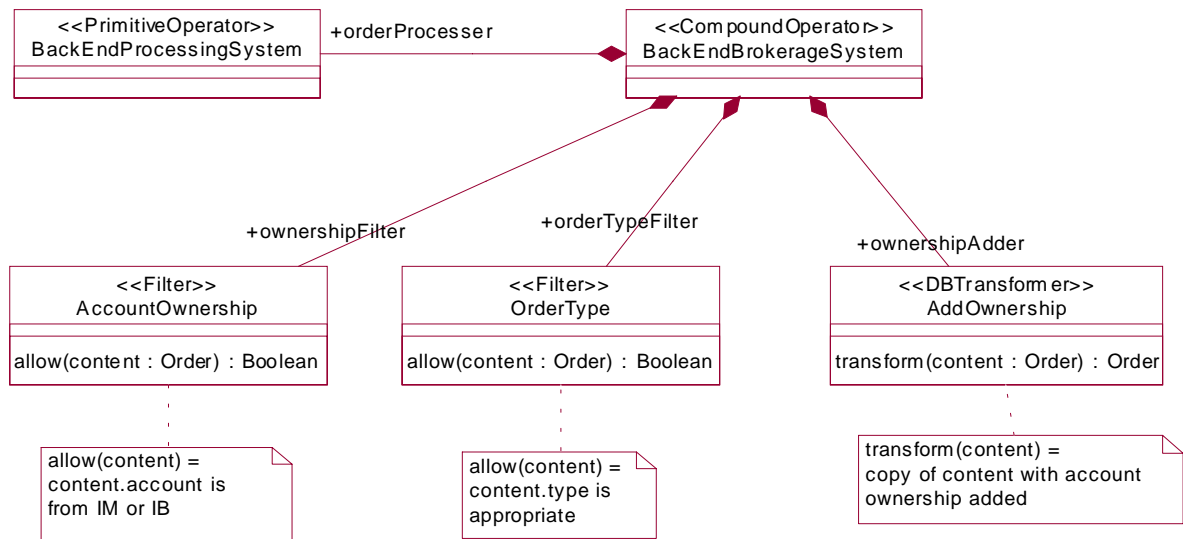

Figure 10-16 Back-end brokerage system - components

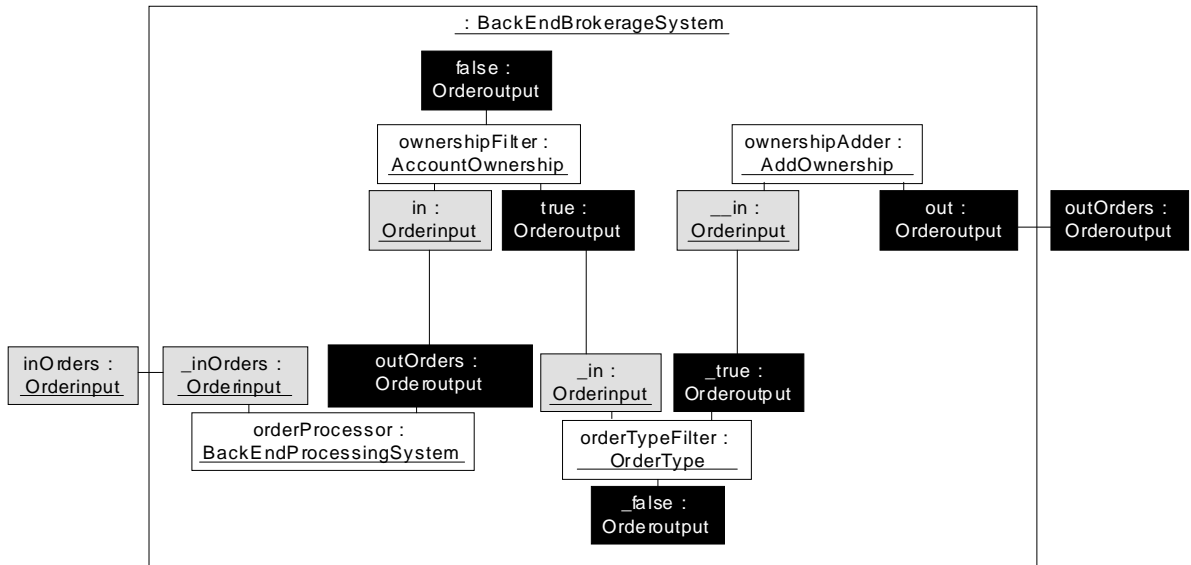

Figure 10-17 Back-end brokerage system - component connections

The message-content format handled by the terminals of the filter and transformer can be deduced from the definition of the allow and transform operations, so we have omitted them here. The terminals for BackEndProcessingSystem are defined by Figure 10-18.

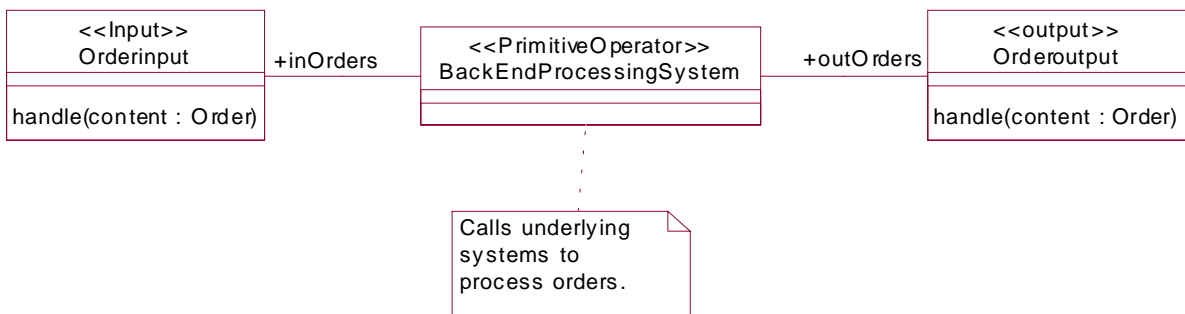

Figure 10-18 Back-end processing system - terminals

10.7 Publication

The order event is then pushed to a Pub/Sub server. It accomplishes the following tasks:

- It transforms the order event into FIXML (a set of XML DTDs for the Financial Industry eXchange - FIX - protocol format).

- It publishes the event with a subject that includes the notion of ownership. The international and institutional customer servers subscribe to different order events: the international server subscribes to events that pertain to its customers, and the institutional server does likewise.

The Pub/Sub server can be modeled quite simply. The first point requires a transformer. Although the second point mentions publish and subscribe, dynamic subscription (a key part of the publication and subscription operators) is not required in this case. Rather, subscriptions are set up statically to filter messages based on their topic, and so this can be shown as a filter instead.

The definition of the components is given in Figure 10-19, and their configuration is given in Figure 10-20.

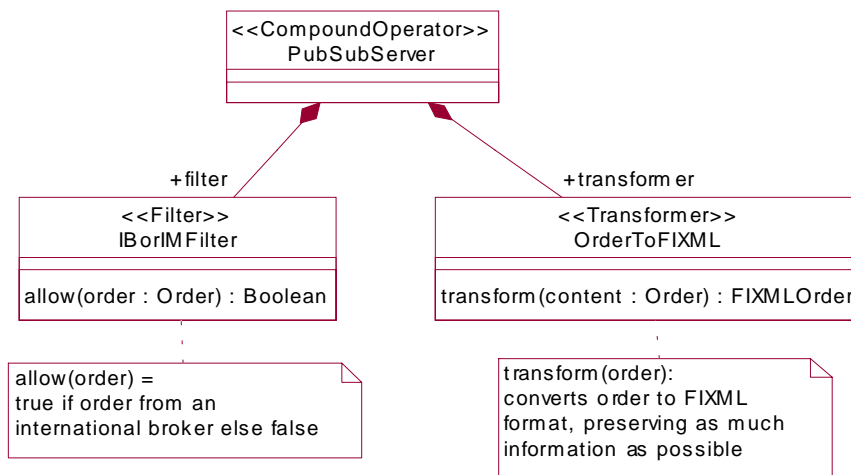

Figure 10-19 Pub/sub server - components

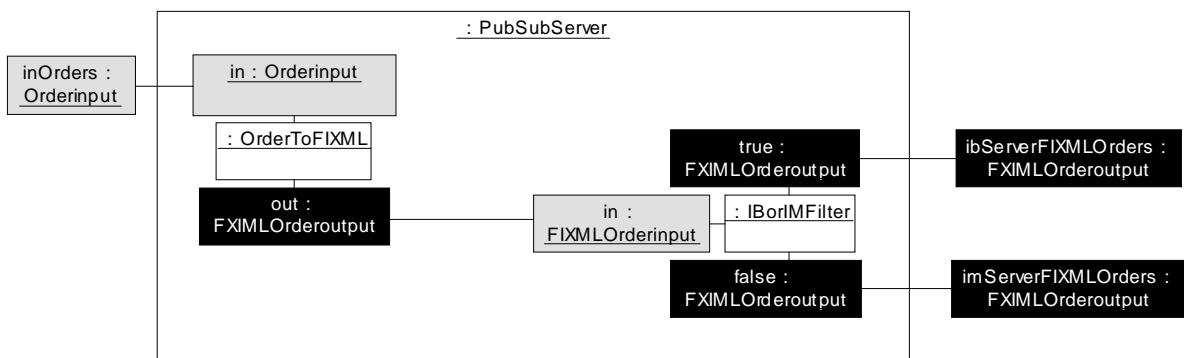

Figure 10-20 Pub/sub server - component connections

The terminal specifications for the filter and the transformer have been omitted, as they can be deduced from the declaration of the allow and transform operations.

11.1 Example

The example in this section is based on a variant of that in Chapter 10. It illustrates the use of the Component Collaboration Architecture (CCA) of the UML Profile for EDOC. The high-level view in Figure 11-1 is a variant of that in Figure 10-2 on page 10-3.

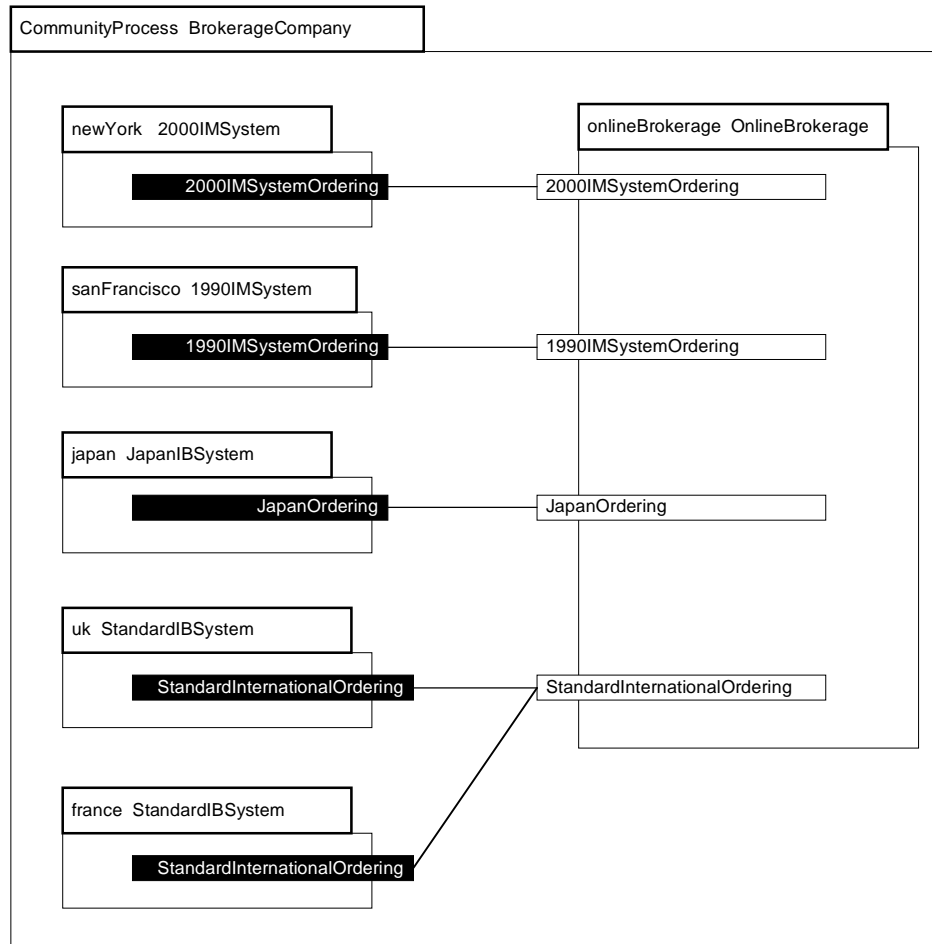

Figure 11-1 BrokerageCompany component connections

The next two figures show the components.

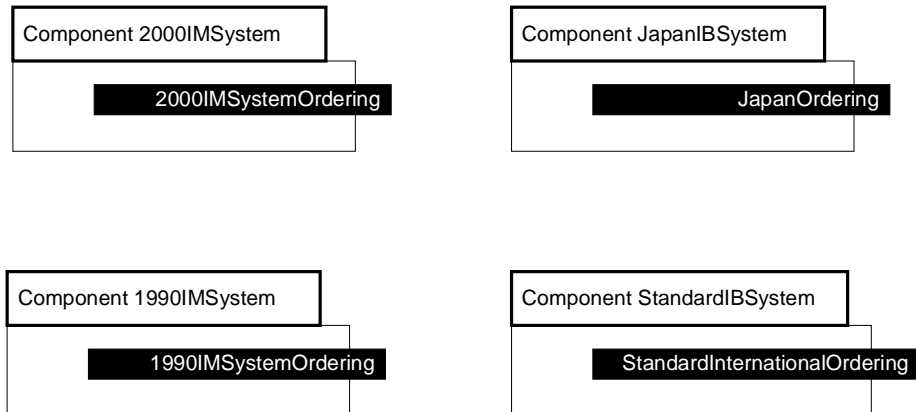

Figure 11-2 Ordering Components

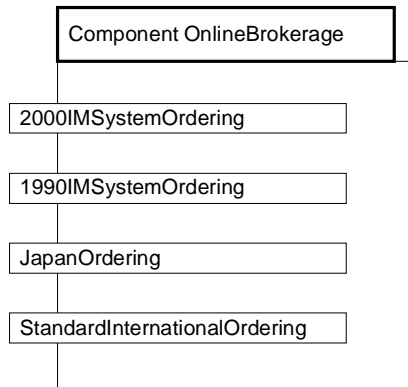

Figure 11-3 OnlineBrokerage Component

The Protocols are in Figure 11-4 to Figure 11-7.

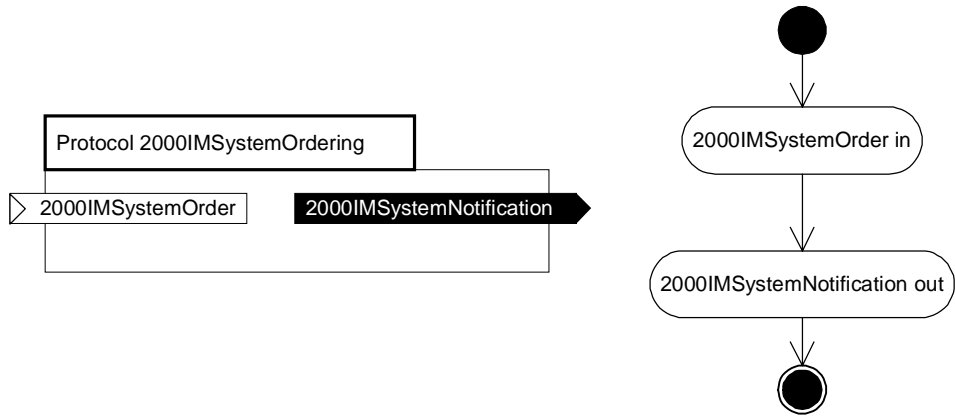

Figure 11-4 2000IMSystemOrdering Protocol

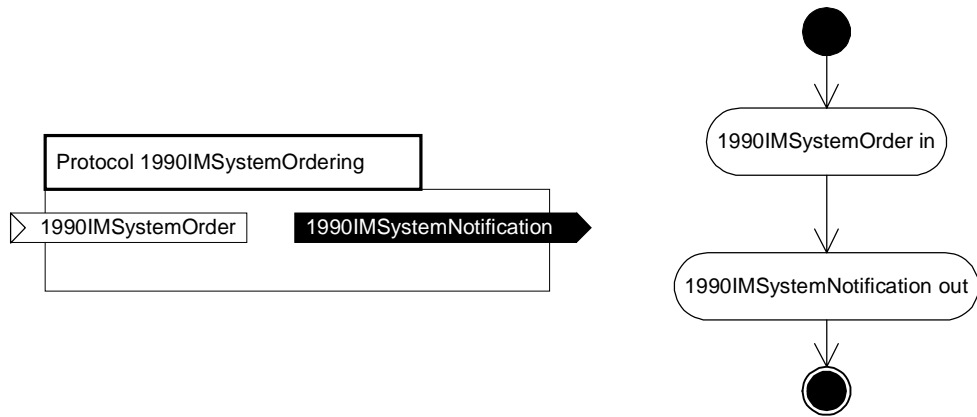

Figure 11-5 1999IMSystemOrdering Protocol

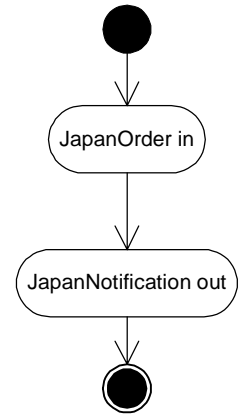
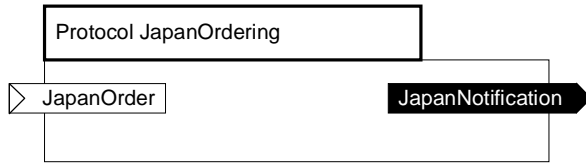

Figure 11-6 JapanOrdering Protocol

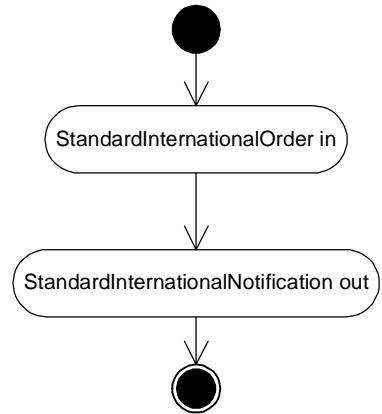
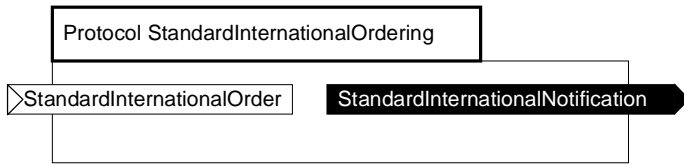

Figure 11-7 StandardInternationalOrdering Protocol

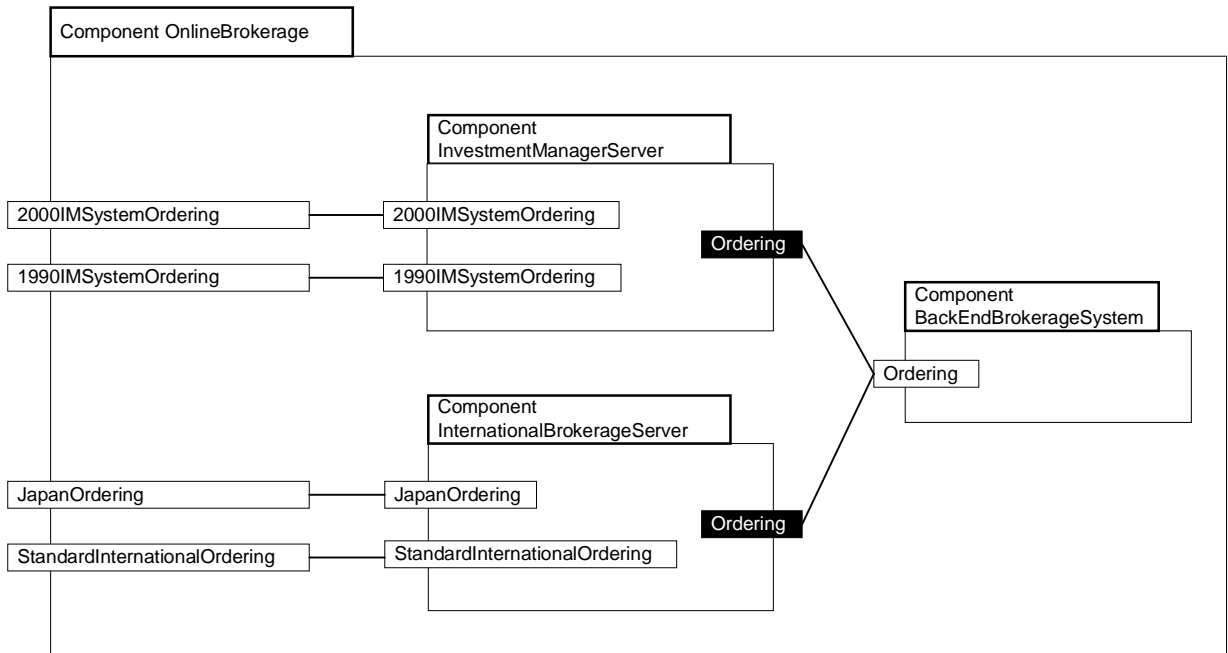

Figure 11-8 Detail of OnlineBrokerage Component

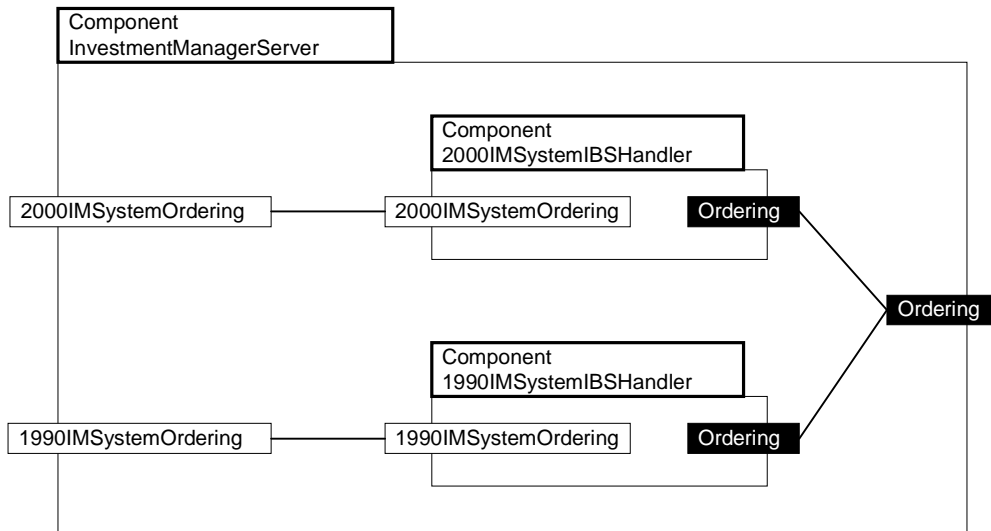

Figure 11-9 Detail of InvestmentManagerServer Component

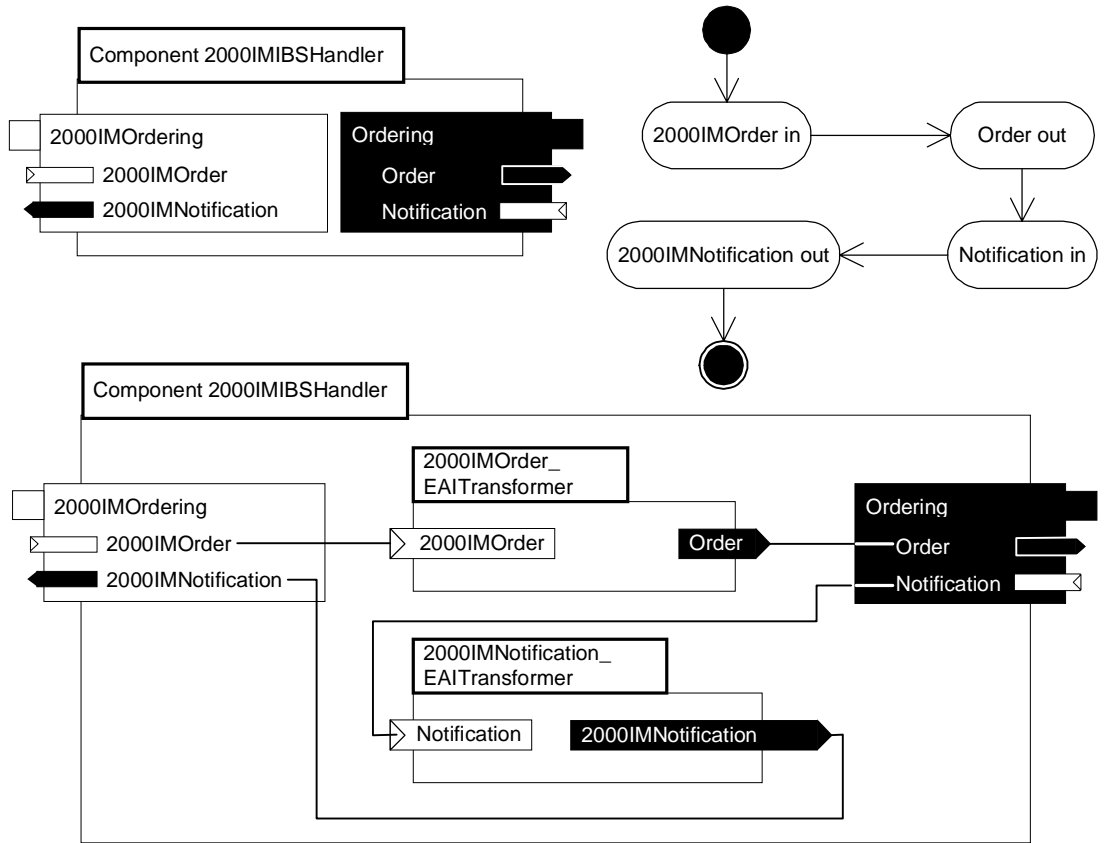

Figure 11-10 Detail of 2000IMIBSHandler Component

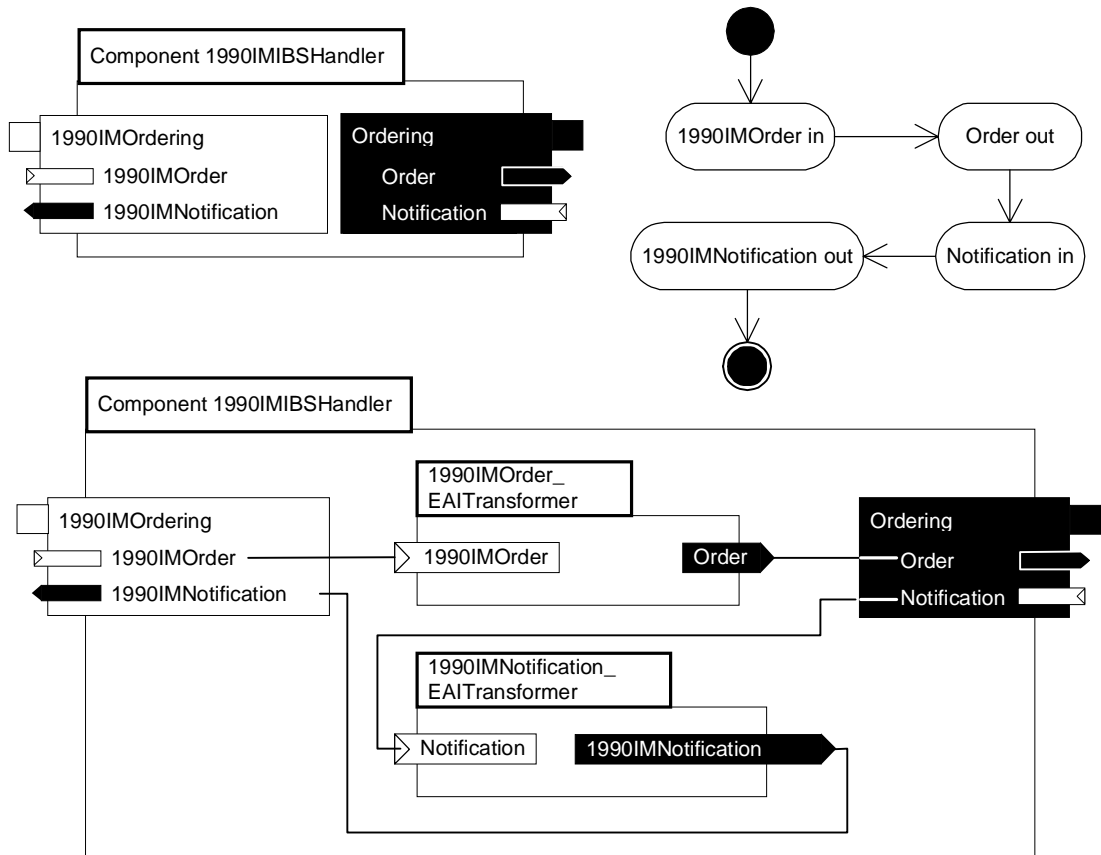

Figure 11-11 Detail of 1990IMIBSHandler Component

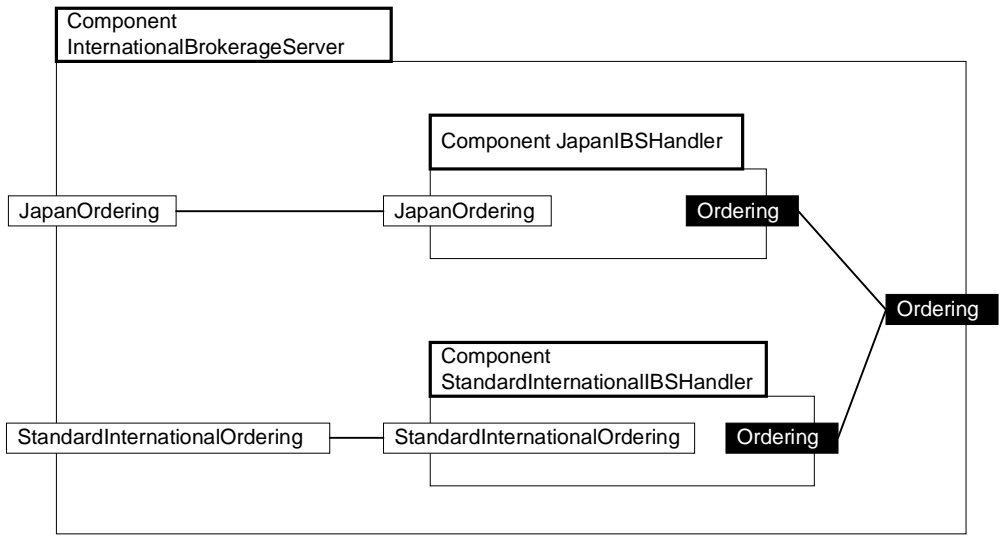

Figure 11-12 Detail of InternationalBrokerageServer Component

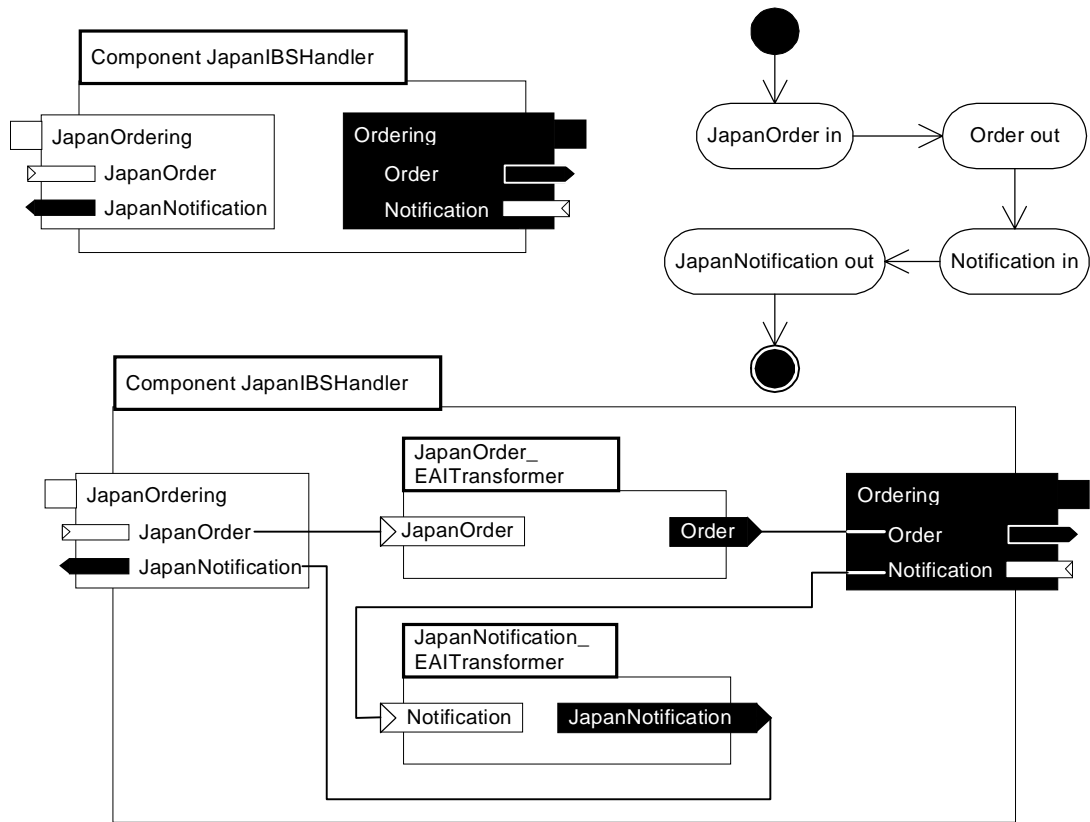

Figure 11-13 Detail of JapanIMIBSHHandler Component

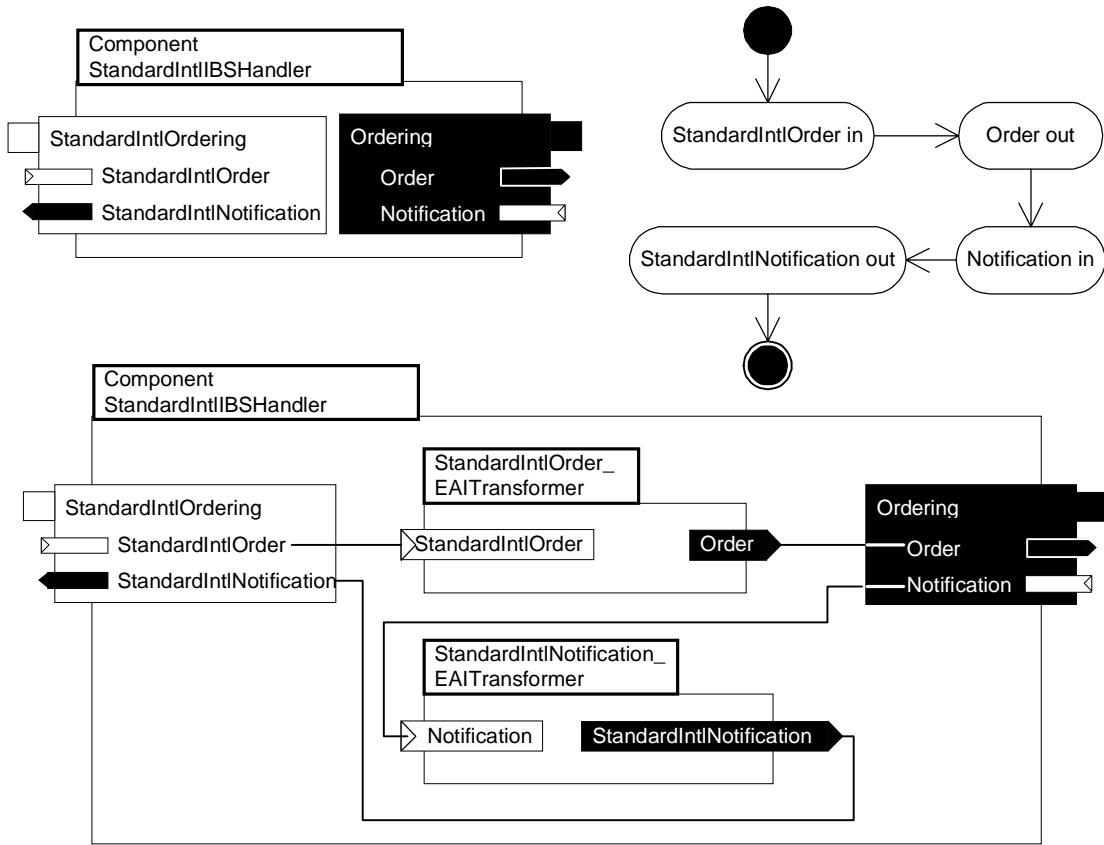

Figure 11-14 Detail of StandardInternationalIMIBSHandler Component

Part 5- Implementation Mappings

Contents

This section contains the following chapters.

Section	Page
12. Mapping to WebSphere MQ Integrator	12-1
13. Java Message Service (JMS)	13-1
14. Language Metamodels	14-1

The profile presented in this specification is intended to provide the basis for modeling EAI architectures, largely at a logical level. However, the implementation of such an architecture requires, of course, the use of various technologies and tools appropriate to integration, such as message brokers. This section presents a selection of mappings of the modeling approaches of the profile into such implementation technologies. The set of technologies discussed here is by no means an exhaustive set of those applicable to EAI, but is simply intended to demonstrate how the profile is usable with such technologies.

Mapping to WebSphere MQ Integrator

12

WebSphere MQ Integrator (WMQI — formerly known as MQSeries Integrator) is IBM's *message broker* product, addressing the needs of business and application integration through management of information flow. It provides services that allow you to:

- Route a message to several destinations, using rules that act on the contents of one or more of the fields in the message or message header.
- Transform a message, so that applications using different formats can exchange messages in their own formats.
- Store and retrieve a message, or part of a message, in a database.
- Modify the contents of a message (for example, by adding data extracted from a database).
- Publish a message to make it available to other applications. Other applications can specify subscriptions that govern receipt of publications related to topics or topic ranges, optionally qualified by SQL-style filters based on message content.

These services exploit the message-oriented middleware (MOM) capability provided by the MQSeries and WebSphere MQ products.

This chapter presents a mapping from the EAI modeling elements to implementation elements; this is intended to show how an architectural model can be mapped to a more detailed implementation level.

12.1 WebSphere MQ Messaging

WebSphere MQ is IBM's new name for MQSeries.

12.1.1 WebSphere MQ Messages

WebSphere MQ messages are modeled as classes that conform to the ContentFormat stereotype. The most abstract version of this models the message as consisting of a header, which is content class MQMD (MQSeries Message Descriptor), and a body which is unconstrained. The MQMD contains the fundamental information required to allow efficient manipulation of a message by the WebSphere MQ messaging system, such as message expiry information and message identifier. The application-data portion of the message is effectively unconstrained, although a message type indicator within the MQMD can be used to indicate what format the message application data conforms to so that it can be checked at runtime.

Where more information is required for the middleware that is responsible for processing a message, extended header information has been defined. A few examples of these extended message formats are shown in Table 12-1; they include the message format expected by the WebSphereMQ CICS and IMS bridges, which enable intercommunication with applications running in CICS and IMS respectively, and the message format used by WMQI for Publish/Subscribe intercommunication.

One point to note about WebSphere MQ messages, which is correctly modeled by the structure shown, is that all of the more complex message types can, if desired, be treated as though they were simple WebSphere MQ messages. In this case, the extended header information is treated as part of the application data of the message.

The MQRFH2 message header is extensible, in that it allows arbitrary name/value data to be held in the header. In addition to mandatory fields contained within the header, it may also contain any number of 'NameValue' sections, which in turn may contain 'Folders.' Each folder may only contain data of the form *name=value*. Since messages are flattened structures, each of the associations between header, folder, and namevalue data is ordered, in that a sequence of values and structures can be reproducibly built from a message, though this ordering is not normally relied on to convey additional information.

Table 12-1 WebSphere MQmessage classes

Class name	Parent class	Stereotype	Description
WMQ Message	NA	ContentFormat	The WMQMessage is a specialization of the ContentFormat stereotype. It is the base format used by all WebSphere MQ applications. The message body is unconstrained. The message header, known as MQMD is fully documented in the WebSphere MQ "Programming Reference Manual."
WMQCICS Bridge Message	WMQMessage	ContentFormat	Used in communication with the WebSphere MQ CICS Bridge.
WMQIMS Bridge Message	WMQMessage	ContentFormat	Used in communication with the WebSphere MQ IMS Bridge.

Table 12-1 WebSphere MQmessage classes

WMQI Message	WMQMessage	ContentFormat	Many WMQI message processing nodes can take advantage of information contained in an extended header, known as the MQRFH2. Full details of the MQRFH2 header are given in the WebSphere MQ Integrator “Programming Reference Manual.”
WMQI Control Message	WMQIMessage	ContentFormat	The WMQIControlMessage class is a subclass of WMQIMessage. It allows control messages (such as add, cancel, and change a subscription). Full details of command messages are given in the WebSphere MQ Integrator “Programming Reference Manual”

12.1.2 WebSphere MQ Message Queuing

WebSphere MQ queues are modeled as classes with the Queue stereotype. They can only hold messages that are in the WMQMessage format. The attributes of each class are not listed here, but are specified in the WebSphere MQ “Application Programming Guide.”

Table 12-2 WebSphere MQ Queue Stereotypes

Class	Parent class	Stereotype	Constraint	Description
WMQQueue	NA	Queue		WebSphere MQ message queue. Parent for all WebSphere MQ queue classes
WMQLocal Queue	WMQQueue	Queue	Holds messages of class WMQMessage (or subclasses)	A physical queue owned by a particular queue manager.
WMQRemote Queue	WMQQueue	Queue	Must refer to a queue that is owned by a different queue manager	A remote queue definition. Specifies the name and location of a queue owned by another queue manager
WMQAlias Queue	WMQQueue	Queue	Must refer to a queue that is owned by the same queue manager	An alias for another queue (a local queue) owned by the same queue manager

WebSphere MQ provides for two different indirection mechanisms, the queue *Alias*, which simply allows a queue to be referred to by a different name, and a *Remote Queue* definition, which identifies a queue managed by a different queue manager. The class diagram for alias queue and remote queue is given in Figure 12-1.

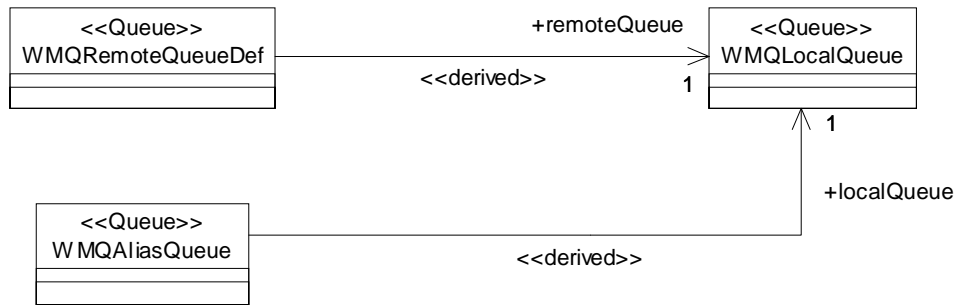

Figure 12-1 WMQRemoteQueue and WMQAliasQueue

At runtime, the WebSphere MQ messaging infrastructure always resolves alias and remote queue definitions to a single local queue by following their ‘remoteQueue’ or ‘localQueue’ associations. Consequently, when specifying an EAI design that uses WebSphere MQ queues, the queue names used by the sender and receiver of a message need not match, but they must resolve to the same local queue.

12.2 WebSphere MQ Integrator Message Flows

12.2.1 Summary

Message routing and transformation is achieved within WMQI by constructing a *message flow*. This is done using a graphical tool, which allows operators to be joined together as *nodes* in a directed graph. A set of subclasses of WMQPrimitiveNode is provided to perform tasks such as a message format conversion, a computation or a database operation; these are modeled as classes with the PrimitiveOperator stereotype. Message flows are modeled in the profile as classes with the CompoundOperator stereotype.

Top-level message flows are initiated via the receipt of a message on a message queue. They may invoke primitive nodes and nested message flows, which appear as *CompoundNodes* in the tool.

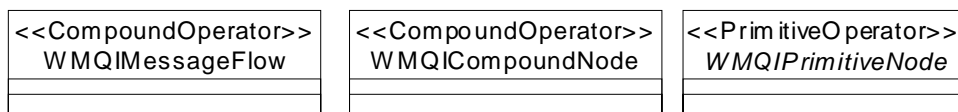

Figure 12-2 Summary of the main usage of operator stereotypes

12.2.2 WMQIMessageFlow

Description

WMQIMessageFlow models the outermost level of composition. At this outermost level, processing is initiated by the receipt of a message on a queue, as represented by WMQIInputNode. Consequently, an instance of WMQIMessageFlow must have at least one WMQIInputNode. This (see Figure 12-3) has the QueuedSource stereotype. Output may be produced by one of three different node classes: WMQIOutputNode, WMQIPublish or WMQIReply. All of these nodes communicate externally using message queues. Consequently, the terminals (the view from the outside) of a message flow are required to be have the QueuedTerminal stereotype.

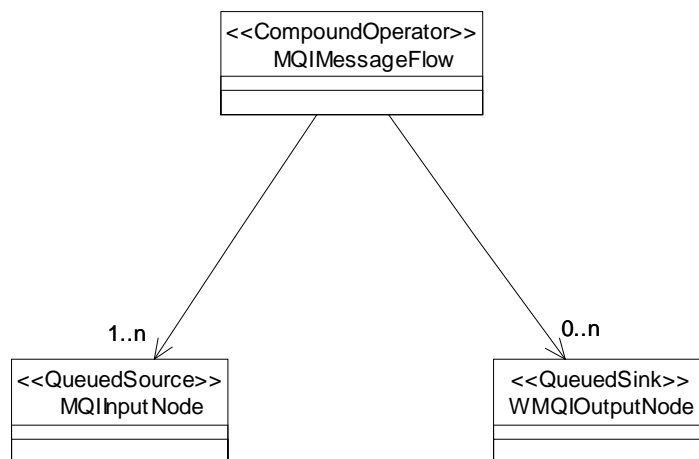

Figure 12-3 WMQIMessageFlow

Constraints

All links between the nodes that are contained in the message flow are synchronous.

WMQIMessageFlow must have at least one WMQIInputNode.

The external terminals of a WMQIMessageFlow have stereotype QueuedTerminal.

The external terminal that represents publication has, in addition, the stereotype PublicationTerminal.

WMQIMessageFlow can contain only WMQICompoundNode, WMQIPrimitiveNode or its subtypes.

WMQIMessageFlow may *not* contain other WMQIMessageFlows (though a WMQIMessageFlow may invoke another WMQIMessageFlow by sending a message to the appropriate queue).

12.2.3 WMQICompoundNode

WMQICompoundNode models all levels of composition *inside* WMQIMessageFlow, exploiting the composition mechanism inherited from the FCM in the EAI Integration metamodel. Processing is initiated by sending a message to one of its terminals. Inside the compound node, this results in the emission of a message by a WMQIInputTerminalNode. Consequently, a WMQICompoundNode must have at least one WMQIInputTerminalNode. The results of message processing are propagated via WMQIOutputTerminals.

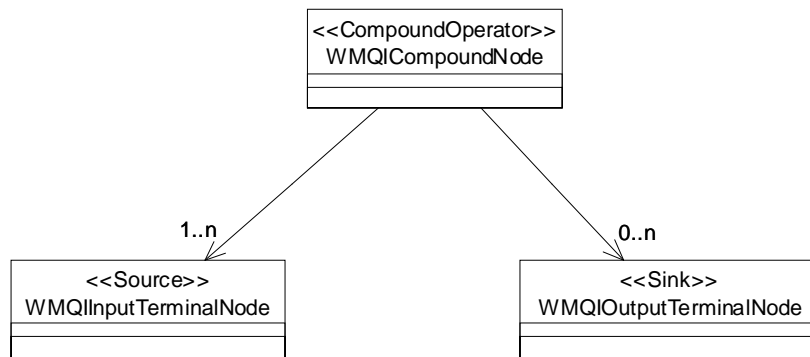

Figure 12-4 Compound and primitive nodes in WMQI

Constraints

A WMQICompoundNode can contain WMQIPrimitiveNodes (and subclasses) and WMQICompoundNodes.

WMQICompoundNode may *not* contain a WMQIMessageFlow.

WMQICompoundNode does not have queued terminals.

All links between the nodes contained in a WMQICompoundNode have synchronization=synchronous.

12.2.4 WMQIPrimitiveNode

Description

WMQIPrimitiveNode is the (abstract) parent class for all WebSphere MQ Integrator message processing nodes.

Constraints

Primitive nodes all expect to receive and process messages that are of the WMQMessage class.

12.2.5 Supplied WMQPrimitiveNodes

The WMQPrimitiveNodes are modeled as classes and are listed in the table below with the appropriate stereotype from the UML Profile for EAI.

The table does not specify the attributes of these classes; the properties of these nodes are specified in the IBM WebSphere MQ “Using the Control Center” manual (IBM document number SC34-5602). Each of these properties may be represented as an attribute of the appropriate type for each class.

The interface required to allow further message processing nodes to be constructed is published by IBM.¹

Table 12-3 Mapping of WMQI primitive nodes to classes with stereotypes from the UML profile for EAI

Class name	Parent Class	Stereotype	Constraint		Description
WMQI Publication	WMQI PSService	Publication Operator	Output terminal is a QueuedPublication Terminal. Input terminal is expect message type WMQIMessage.		The Publication node filters and transmits the output from a message flow to subscribers who have registered an interest in a particular set of topics. The Publication node must always be an output node of a message flow and has no output terminals of its own.
WMQI PSService	WMQI PrimitiveNode	Primitive Operator	NA	The PS Service node allows for the interception of publications after they have passed the subscription filters.	
WMQICheck	WMQI PrimitiveNode	Filter	NA	A Check node compares the format of a message arriving on its input terminal with its message-type specification.	
WMQI Compute	WMQI PrimitiveNode	Transformer	NA	The Compute node constructs an output message. The elements of the output message can be defined using an SQL expression, and can be based on elements of both the input message and data from an external database.	
WMQI Database	WMQI PrimitiveNode	Primitive Operator	NA	The Database node applies an SQL expression to an external database table. Data from the message input to this node can be used in the SQL expression.	
WMQI DataDelete	WMQI DatabaseNode	Primitive Operator	NA	A DataDelete node deletes one or more rows from a table in a specified database. Data from the input message can be used as part of the expression that determines which rows are deleted.	
WMQI DataInsert	WMQI Database	Primitive Operator	NA	A DataInsert node inserts a new row into a database table. Data from the input message can be included in the database insert expression.	
WQMIDataUpdate	WMQI Database	Primitive Operator	NA	A DataUpdate node updates one or more rows of data in a specified database. Data from the input message can be used as part of the expression that determines which rows are updated.	
WQMIWarehouse	WMQI Database	Primitive Operator	NA	A Warehouse node saves a copy of the input message in a database table by inserting it in a new row.	

1. WebSphere MQ Programming Guide SC34-5603

Table 12-3 Mapping of WMQI primitive nodes to classes with stereotypes from the UML profile for EAI

WQMI Extract	WQMI Compute	Transformer	NA	The Extract node derives an output message from an input message. The output message comprises only those elements of the input message that are specified for inclusion when configuring the Extract node.
WQMIFilter	WQMI PrimitiveNode	Filter	NA	A Filter node routes a message according to message content using a filter expression specified in SQL. The filter expression can include elements of the input message or message properties. It can also use data held in an external database. The output terminal to which the message is routed depends on whether the expression is evaluated to true, false, or unknown.
WQMIInput	WQMI PrimitiveNode	QueuedSource	NA	Receives a WebSphere MQ message from a specified queue
WQMI Output	WQMI PrimitiveNode	QueuedSink	NA	Sends a WebSphere MQ message to the specified target queues
WQMIREply	WQMIOOutput	QueuedSource	NA	Sends a reply message to the WebSphere MQ queue specified in the message header.
WQMIFlow Order	WQMI PrimitiveNode	Primitive Operator	NA	The FlowOrder node enables you to specify the order in which each message is propagated to each (of two) output terminals. The message is only propagated to the second output terminal if propagation to the first output terminal is successful.
WQMIReset Content Descriptor	WQMI PrimitiveNode	Transformer	NA	The ResetContentDescriptor node takes the bit stream of the input message and reparses it using a different message template from the same or a different message dictionary. The node can reset any combination of message domain, set, type, and format.
WQMITry Catch	WQMI PrimitiveNode	Primitive Operator	NA	The TryCatch node provides a special handler for exception processing. The input message is initially routed on the try terminal of this node. If an exception is subsequently thrown by a downstream node, it is caught by this node, which then routes the original message to its catch terminal.
WQMI Throw	WQMI PrimitiveNode	Primitive Operator	NA	The Throw node provides a mechanism for throwing an exception within a message flow. The exception might be caught and processed by a preceding TryCatch node within the message flow, or handled by the MQInput node.
WQMI Aggregate Reply	WQMI PrimitiveNode	Aggregator	NA	The AggregateReply node holds related messages until either a complete set has arrived (according to a specified condition) or a time limit has elapsed.

12.2.6 The Role of the WMQI message-broker topology

A set of WMQI message brokers is interconnected and governed by the WMQI Configuration Manager, which we represent by the class WMQIntegrator. WMQIntegrator owns all executing WMQIMessageFlows, as shown in Figure 12-5. The Configuration Manager deploys these to selected message brokers. The set of WMQI message brokers also acts as a SubscriptionOperator, allowing subscriptions to be added to, and removed from, the subscription table (see Table 12-4). The topology

is governed by the Configuration Manager. All WMQIPublication nodes that are owned by message flows in the same broker topology share the same subscription table. (The implementation optimizes the distribution of the subscription table.)

Table 12-4 WMQIntegrator class definition table

Class	Stereotype	Constraint	Description
WMQIntegrator	Subscription Operator	Input terminal is a QueuedInputTerminal. Expects to receive messages in WMQICommandMessage format.	The WMQI message broker topology when acting as a subscription operator. Subscriptions are added, removed and updated on WMQIntegrator by sending a message that conforms to the WMQICommandMessage format to the WMQI command queue.

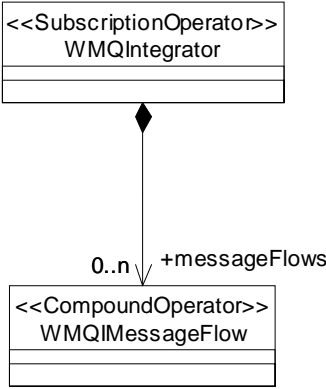

Figure 12-5 WMQIntegrator class diagram

Java Message Service (JMS)

13

The Java Message Service (JMS)¹ is part of the 1.3 release of the J2EE™ platform specification.² It specifies a point-to-point (PTP) domain and a publish-subscribe (Pub/Sub) domain. The JMS entities of interest in modeling are destinations, message producers and message consumers. These are summarized in the table:

JMS Parent	PTP Domain	Pub/Sub Domain
Destination	Queue	Topic
MessageProducer	QueueSender	TopicPublisher
MessageConsumer	QueueReceiver, QueueBrowser	TopicSubscriber

These entities are all defined in the EAI Integration metamodel, except that the distinction between receivers and browsers is not made. A JMS QueueReceiver receives a message destructively from a queue, whereas a JMS QueueBrowser leaves it on the queue so that it may be read again.

13.1 PTP Domain

A JMS client acting as a sender creates one or more JMS QueueSender objects and sends messages on them. These are modeled as a class JMSQueueSender with stereotype QSource.

1. For the JMS 1.2 specification see <http://java.sun.com/products/jms/>

2. At the time of writing, J2EE 1.3 is still in draft. See <http://java.sun.com/j2ee/>

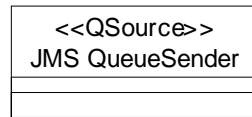

Figure 13-1 JMS QueueSender

A JMS client acting as a receiver creates one or more JMS QueueReceiver or QueueBrowser objects and listens on them. A JMS QueueReceiver or QueueBrowser object may include a JMS message selector, which has the effect of a local EAI filter.

In order to model this optional filtering behavior, QueueReceiver and QueueBrowser are both modeled as <<CompoundOperator>> classes, each with a single queued input terminal. The composition that defines them contains a class QDataIn of stereotype <<QSource>>. The class QDataIn makes messages received at the input terminal available to the JMS Message Selector (if there is one) but does not remove them from the queue. The *emit* operation of the JMSMessageSelector (a <<Stream>>) emits the message from the stream, provided it passes the chosen filter condition, and passes it on to the sink. The <<QSource>> QDataIn and the stream both share the same queue resource. This means that messages remain on the input queue unless they are explicitly sent to the sink.

The difference between QueueReceiver and QueueBrowser lies in the behavior of the stream. For QueueBrowser, the stream does not remove messages; it proceeds forward through them, but they remain available for other receivers and browsers. For QueueReceiver, the stream removes those messages that pass the filter condition of the JMSMessageSelector; the remaining messages are available for access by other receivers and browsers.

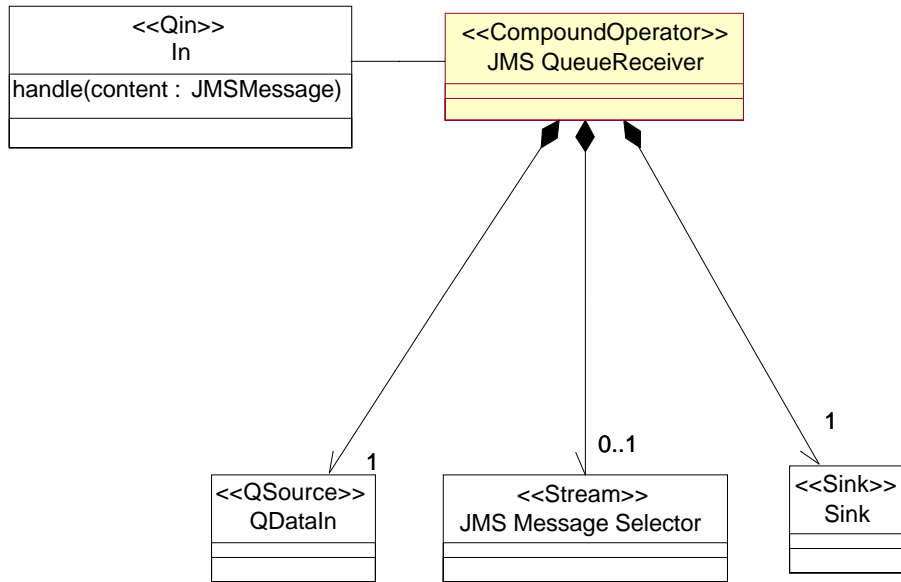

Figure 13-2 JMS QueueReceiver

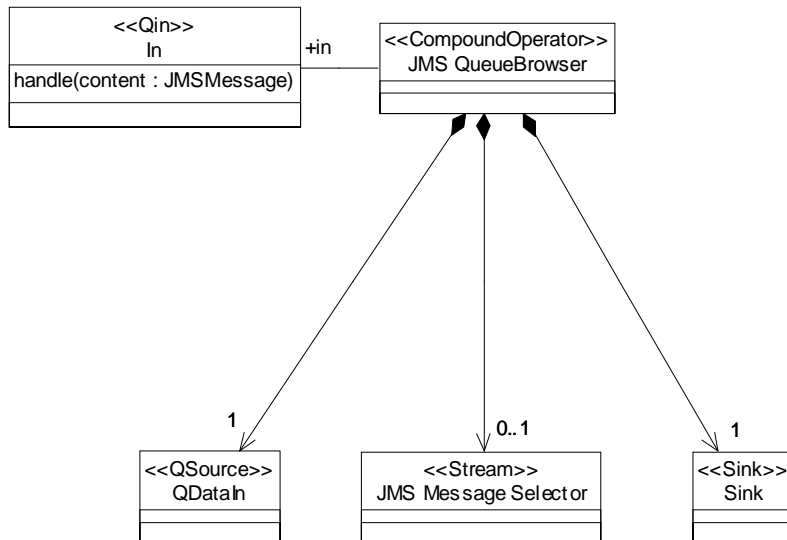

Figure 13-3 JMS QueueBrowser

13.2 Pub/Sub Domain

A JMS client acting as a subscriber registers its interest in topics by creating one or more JMS TopicSubscriber objects and listening on them. To model this in the EAI profile, we separate the creation of a JMS TopicSubscriber from the activity of listening to the topic.

We model the ‘listener’ aspect as a class JMSSubscriberListener of stereotype Sink that expects a JMSMessage as its input.

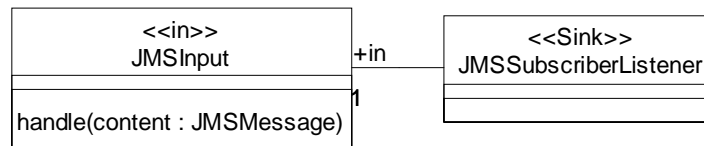

Figure 13-4 A JMSSubscriberListener expects incoming messages

A JMS TopicSubscriber object refers to a JMS Topic object, and it may include a JMS message selector. A JMS Topic may refer to several EAI topics.

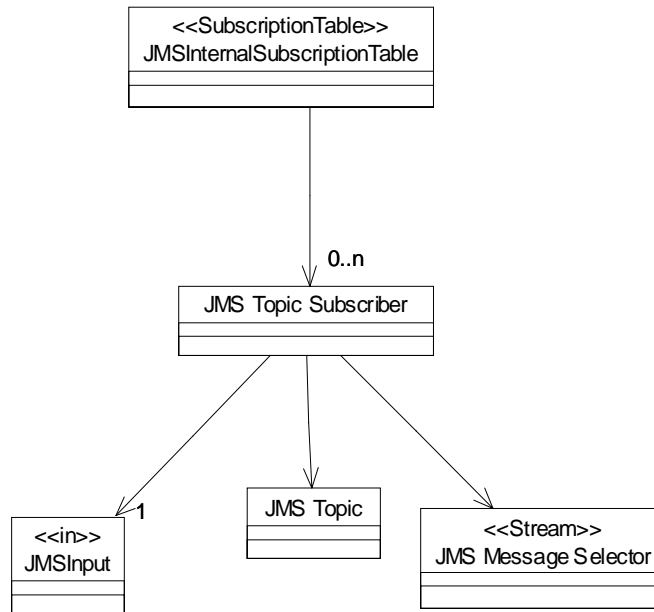

Figure 13-5 Model for the content of the JMS subscription table

Creating a JMS subscriber object causes a subscription to be registered with the JMS infrastructure. We model the element that registers the subscription as a JMSTopicSubscriberCreator of stereotype <<source>> that sends a subscription to the JMS subscription infrastructure.

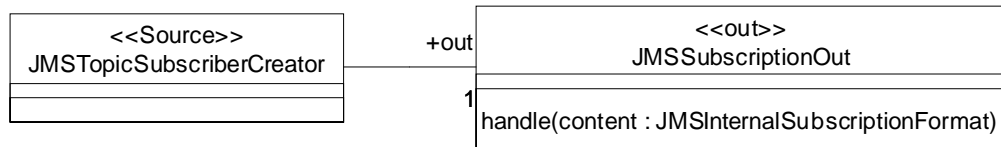

Figure 13-6 JMSTopicSubscriberCreator

We model the subscription infrastructure via a class JMSSubscriptionInfrastructure of stereotype <<SubscriptionOperator>>. This expects a message of the arbitrary 'JMSSubscriptionData' format.

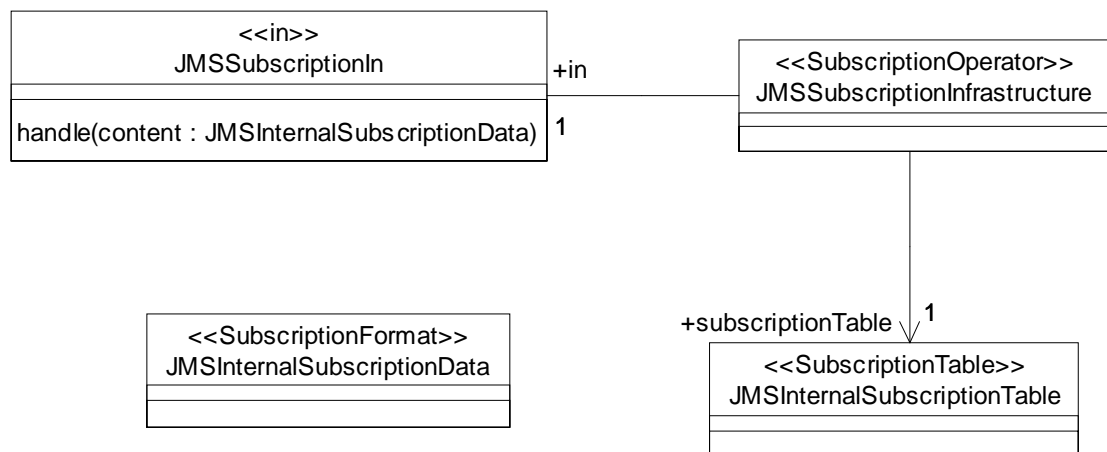

Figure 13-7 JMSSubscriptionInfrastructure

A JMS client acting as a publisher creates one or more JMS TopicPublisher objects that identify topics via JMS Topic objects. The publisher produces messages and sends them on one or more topics, using the associated JMS TopicPublisher object.

This has the effect of sending them to a PublicationOperator (Figure 13-9), which forwards them to the appropriate EAI destinations; these can include JMS subscribers.

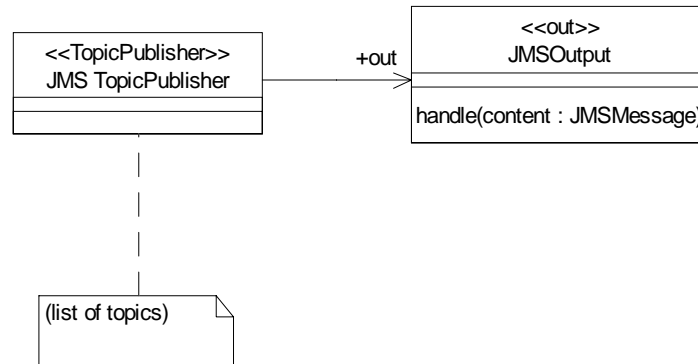

Figure 13-8 A JMS TopicPublisher

We model the existence of a publication mechanism via the class `JMSPublicationInfrastructure` of stereotype `<<PublicationOperator>>`. This is not a separable element of JMS, but is part of the JMS infrastructure. All `JMSTopicPublishers` for a given JMS environment should be connected to the same `JMSPublicationInfrastructure`.

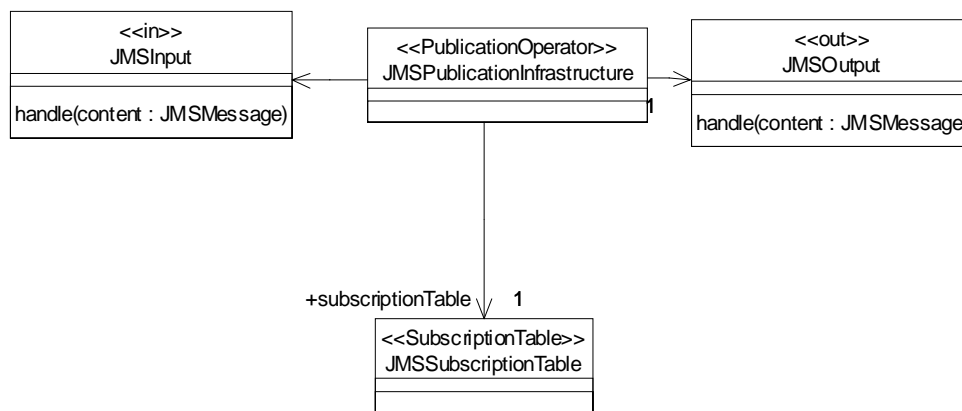

Figure 13-9 JMSPublicationInfrastructure

14.1 COBOL Metamodel

The COBOL metamodel is used by enterprise application programs to define data structures (semantics), which represent connector interfaces.

The goal of this COBOL model is to capture the information that would be found in the Data Division. This model is intended to be used only as read-only to convert COBOL data division into its XML equivalent. This model is not intended to be used as a converter from XML code into a COBOL data division equivalent. The following figures illustrate the classes that constitute the COBOL metamodel and show how the classes relate to each other. Following the diagrams is a brief explanation of what each class represents.

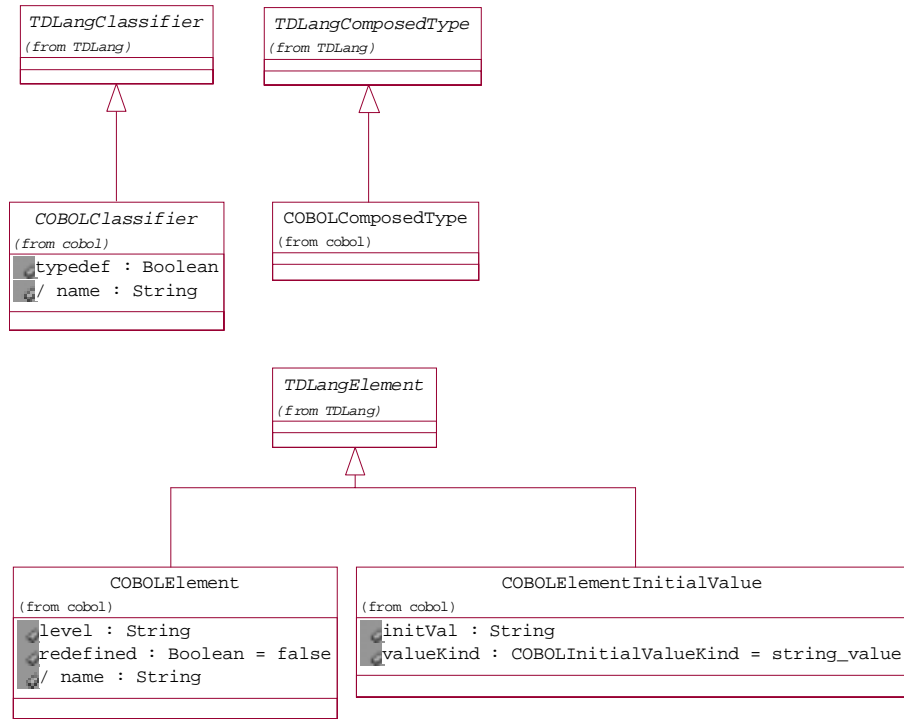

Figure 14-2 TDLang to COBOL

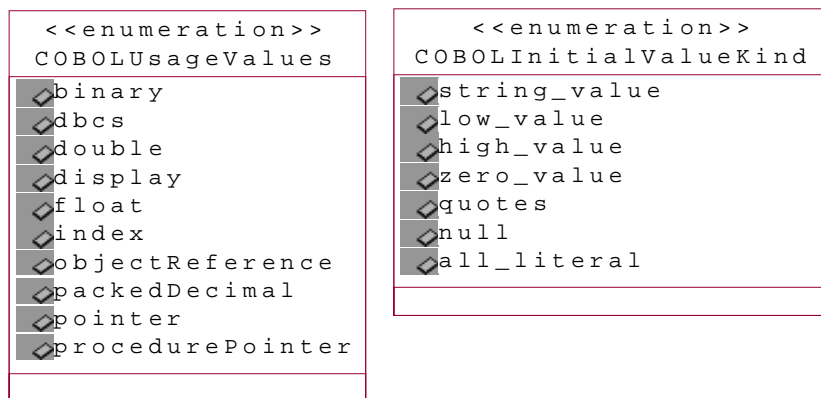

Figure 14-3 COBOL Stereotypes

14.1.1 COBOL Metamodel Descriptions

14.1.1.1 COBOL66Element

COBOL66Element represents the COBOL 66 data level.

For example:

```
01 DATA-GROUP PIC 9.  
    03 DATA1 VALUE 1.  
    03 DATA2 VALUE 2.  
    03 DATA3 VALUE 3.  
66 SUB-DATA RENAMES DATA1 THROUGH DATA2.  
66 AKA-DATA3 RENAMES DATA3.
```

In this example SUB-DATA refers to contents in DATA1 and DATA2.

14.1.1.2 COBOL88Element

COBOL88Element represents the COBOL 88 data level.

For example:

```
1 TESTX PIC .  
    88 TRUEX VALUE 'T' 't'.          *(TRUEX has 2 values)  
    88 FALSEX VALUE 'F' 'f'.        *(FALSEX has 2 values)
```

Where TRUEX and FALSEX are condition names for the TESTX variable if value equals ('T' or 't') or ('F' or 'f'), respectively. So if TESTX = 'T' or 't' then TRUEX = TRUE and FALSEX = FALSE; If TESTX = 'F' or 'f' then FALSEX = TRUE and TRUEX = FALSE.

14.1.1.3 COBOL88ElementValue

COBOL88ElementValue represents the values specified by COBOL88Element.

14.1.1.4 COBOLAddressingType

COBOLAddressingType is used for index values, pointer values, and procedure pointer values.

14.1.1.5 COBOLAlphabeticType

COBOLAlphabeticType represents a picture string consisting of alphabetic characters.

14.1.1.6 COBOLAlphaNumericEditedType

COBOLAlphaNumericEditedType represents a picture string consisting of either alphabetic or alphanumeric type and at least one blank (B), zero (0), or slash (/).

14.1.1.7 COBOLAlphaNumericType

COBOLAlphaNumericType represents a picture string consisting of alphabetic and numeric characters.

14.1.1.8 COBOLClassifier

COBOLClassifier represents all data types of the COBOL metamodel. COBOLClassifier is the parent class of COBOLComposedType and COBOLSimpleType.

14.1.1.9 COBOLComposedType

COBOLComposedType represents a nested declaration that contains additional elements. COBOLComposedType has a single aggregation to include all the elements that are part of this composition.

14.1.1.10 COBOLDBCSType

COBOLDBCSType represents double byte character strings whose code is represented by 16 bits instead of 8 bits.

14.1.1.11 COBOLElement

COBOLElement represents data elements in the COBOL metamodel.

14.1.1.12 COBOLElementInitialValue

COBOLElementInitialValue stores the value assigned to a COBOLElement at the time storage is allocated for it.

14.1.1.13 COBOLExternalFloatType

COBOLExternalFloatType represents how COBOL floating points are displayed to the user.

14.1.1.14 COBOLFixedLengthArray

COBOLFixedLengthArray represents an array declared as OCCURS N TIMES.

14.1.1.15 COBOLInitialValueKind

COBOLInitialValueKind is an enumeration of types supported in an initialized element.

14.1.1.16 COBOLInternalFloatType

COBOLInternalFloatType represents COBOL's internal float data type.

14.1.1.17 COBOLNumericEditedType

COBOLNumericEditedType represents formatted numeric values.
COBOLNumericEditedType values can be decorated with characters such as decimal point (.), dollar sign (\$), and arithmetic signs (+, -, *, /).

14.1.1.18 COBOLNumericType

COBOLNumericType represents a numeric data number, including the implied decimal point and operational sign. COBOLNumericType can represent binary, packed decimal, and zoned decimal types.

14.1.1.19 COBOLObjectReferenceType

COBOLObjectReferenceType represents an object declared in COBOL as USAGE OBJECT REFERENCE.

14.1.1.20 COBOLRedefiningElement

COBOLRedefiningElement represents an element declared with the REDEFINES clause. COBOLRedefiningElement allows different data description entries to describe the same computer storage area.

14.1.1.21 COBOLSimpleType

COBOLSimpleType is an abstract class that contains attributes shared by all simple types in the COBOL metamodel.

14.1.1.22 COBOLSourceText

This class contains the entire source code (including comments) and its associated line number.

14.1.1.23 COBOLUnicodeType

COBOLUnicodeType represents COBOL data declared in Unicode format.

14.1.1.24 *COBOLUsageValues*

COBOLUsageValues is an enumeration of values supported in the USAGE clause.

14.1.1.25 *COBOLVariableLengthArray*

COBOLVariableLengthArray represents an array declared as OCCURS DEPENDING ON.

14.2 *PL/I Metamodel*

The PL/I language metamodel is used by enterprise application programs to define data structures (semantics), which represent connector interfaces.

This language model for PL/I attempts to describe PL/I declares that have the storage class of either PARAMETER, STATIC or BASED. CONTROLLED, AUTOMATIC and DEFINED are not supported.

In the PL/I languages, extents(that is string lengths, area sizes and array bounds) may, in general, be declared as constants, as expressions to be evaluated at run-time, as asterisks, or as defined via the REFER option; however, none of these choices are valid for all storage classes.

Based variables whose extents are not constant and not defined via the REFER option are excluded from this model, as are parameters whose extents are specified via asterisks.

The INITIAL attribute (which is not valid for parameters in any case) will be ignored by the model. The following figures illustrate the classes that constitute the PL/I metamodel and show how the classes relate to each other. Following the diagrams is a brief explanation of what each class represents.

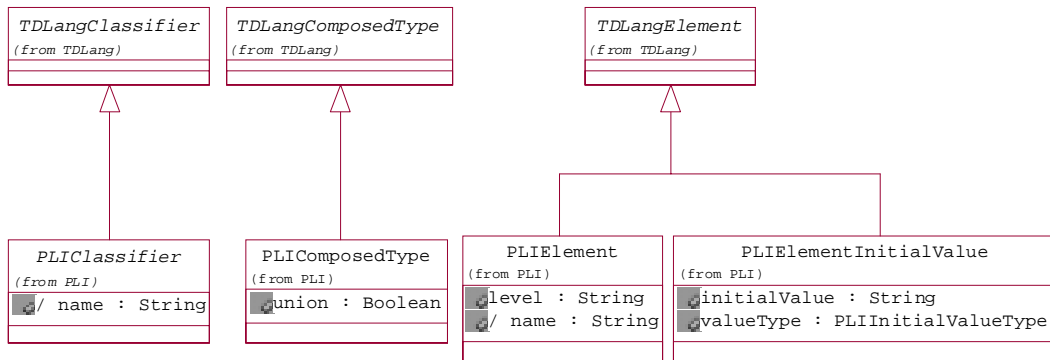

Figure 14-5 TDLang to PL/I

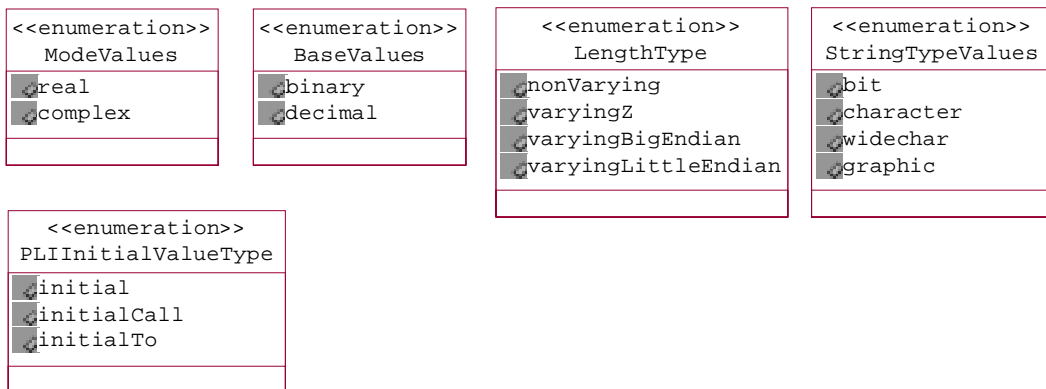

Figure 14-6 PL/I Stereotypes

14.2.1 PL/I Metamodel Descriptions

14.2.1.1 PLIAlias

PLIAlias represents an alias defined for a collection of data attributes.

14.2.1.2 PLIAreaType

PLIAreaType represents an area variable that describes an area of storage reserved for the allocation of a based variable.

14.2.1.3 *PLIArithmeticType*

PLIArithmeticType represents data types that can be represented as rational numbers.

14.2.1.4 *PLIArray*

PLIArray represents an n-dimensional collection of elements that have identical attributes.

14.2.1.5 *PLIBaseValues*

Base Values is an enumeration of base values used by PLIFloatType.

14.2.1.6 *PLIClassifier*

PLIClassifier represents all data types of the PL/I metamodel.

14.2.1.7 *PLICodedStringType*

PLICodedStringType represents a character string data item that can contain any of the available set of characters.

14.2.1.8 *PLIComposedType*

PLIComposedType is a collection of member elements that can be structure, unions, or elementary variables and arrays. PLIComposedType has a single aggregation to include all the elements that are a part of this composition.

14.2.1.9 *PLIComputationalType*

PLIComputationalType represents types used in computations to produce a desired result. Arithmetic and string data types constitute computational data type.

14.2.1.10 *PLIElement*

PLIElement represents data elements in the PL/I metamodel.

14.2.1.11 *PLIElementInitialValue*

PLIElementInitialValue stores the value assigned to a PLIElement at the time storage is allocated for it.

14.2.1.12 *PLIEntryType*

PLIEntryType represents an entry constant or the value of an entry variable.

14.2.1.13 *PLIFileType*

PLIFileType represents the FILE attribute that specifies the associated file name or file variable.

14.2.1.14 *PLIFixedBoundArray*

PLIFixedBoundArray represents a fixed size array.

14.2.1.15 *PLIFixedLboundArray*

PLIFixedLboundArray represents an array whose lower bound is fixed.

14.2.1.16 *PLIFixedLengthArea*

PLIFixedLengthArea represents a PLIAreaType whose area size is fixed.

14.2.1.17 *PLIFixedLengthString*

PLIFixedLengthString represents a PLICodedStringType whose string length is fixed.

14.2.1.18 *PLIFloatType*

PLIFloatType represents numbers stored in floating-point format.

14.2.1.19 *PLIFormatType*

PLIFormatType represents a format list is to be used in a FORMAT statement.

14.2.1.20 *PLIHandleType*

PLIHandleType represents a variable as a pointer to a structure type.

14.2.1.21 *PLIHboundArray*

PLIHboundArray represents an array whose upper bound is fixed.

14.2.1.22 *PLIInitialValueType*

PLIInitialValueType is an enumeration of initial value types used by PLIElementInitialValue.

14.2.1.23 *PLIntegerType*

PLIntegerType represents numbers stored in binary fixed-point format.

14.2.1.24 *PLILabelType*

PLILabelType represents a label constant or the value of a label variable.

14.2.1.25 *PLILengthType*

PLILengthType is an enumeration of length types supported by PLICodedStringType.

14.2.1.26 *PLIModeValues*

PLIModeValues is an enumeration specifying the mode used by PLIArithmeticType.

14.2.1.27 *PLINamedStructureType*

PLINamedStructureType represents a named structure. A structure is a collection of member elements that can be structure, unions, or elementary variables and arrays.

14.2.1.28 *PLINamedType*

PLINamedType represents user-defined name types.

14.2.1.29 *PLINonComputationalType*

PLINonComputationalType represents values used to control execution of a PL/I program.

14.2.1.30 *PLIOffsetType*

PLIOffsetType represents an offset value relative to the locations of a base variable.

14.2.1.31 *PLIOrdinalType*

PLIOrdinalType represents a named set of ordered values. The values of PLIOrdinalType are stored in PLIOrdinalValue.

14.2.1.32 *PLIOrdinalValue*

PLIOrdinalValue stores the values specified by PLIOrdinalType.

14.2.1.33 *PLIPackedType*

PLIPackedType represents numbers stored in packed-decimal format.

14.2.1.34 *PLIPictureStringType*

PLIPictureStringType represents a fixed-length character data item, with the additional restriction that the data item can only contain characters from certain subsets of the complete set of available characters.

14.2.1.35 *PLIPictureType*

PLIPictureType represents numeric data held in character form.

14.2.1.36 *PLIPointerType*

PLIPointerType represents a pointer.

14.2.1.37 *PLISimpleType*

PLISimpleType is an abstract class that contains attributes shared by all simple types in the PL/I metamodel.

14.2.1.38 *PLISourceText*

This class contains the entire source code (including comments) and its associated line number.

14.2.1.39 *PLIStringType*

PLIStringType represents a sequence of contiguous characters, bit, widechars, or graphics that are treated as a single data item.

14.2.1.40 *PLIStringTypeValues*

PLIStringTypeValues is an enumeration of types supported by PLICodedStringType.

14.2.1.41 *PLIVariableBoundArray*

PLIVariableBoundArray represents an array whose upper and lower bound are both variable.

14.2.1.42 *PLIVariableLengthArea*

PLIVariableLengthArea represents a PLIAreaType whose area size is variable.

14.2.1.43 PLIVariableLengthString

PLIVariableLengthString represents a PLICodedStringType whose string length is variable.

14.3 C Metamodel

The C metamodel including C Main and User Types (i.e. user defined types) is a MOF Class instance at the M2 level.

The C metamodel is used by enterprise application programs to define data structures, that represent connector interfaces. The following figures illustrate the classes that constitute the C metamodel and show how the classes relate to each other. Following the diagrams is a brief explanation of what each class represents.

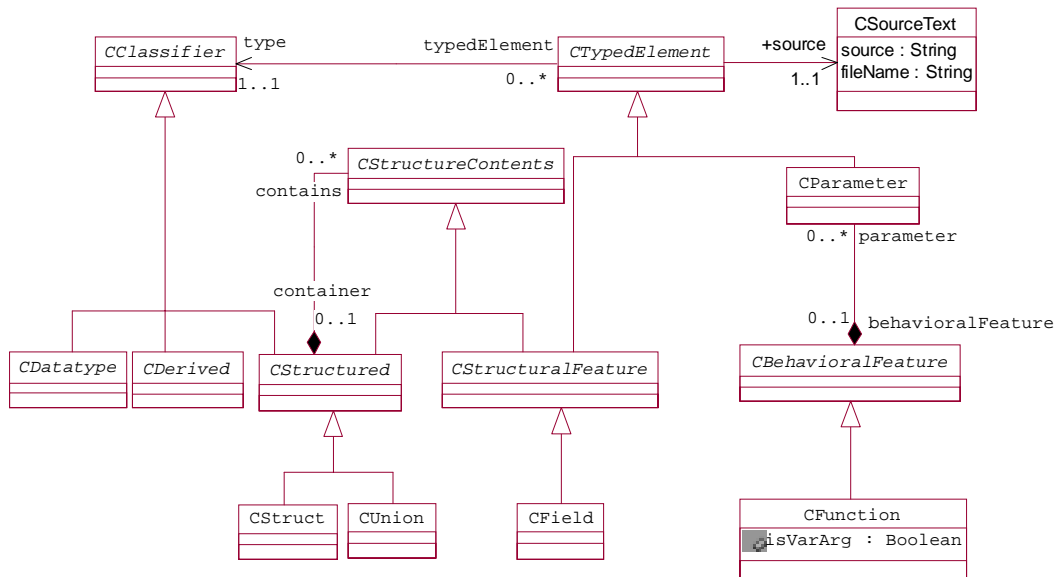

Figure 14-7 C Metamodel

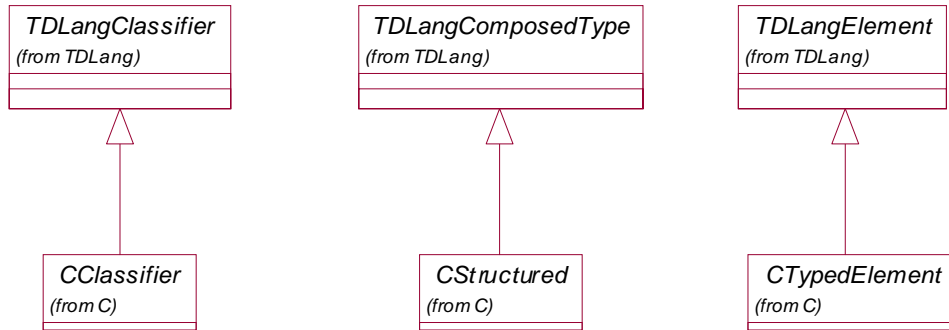

Figure 14-8 TDLang to C

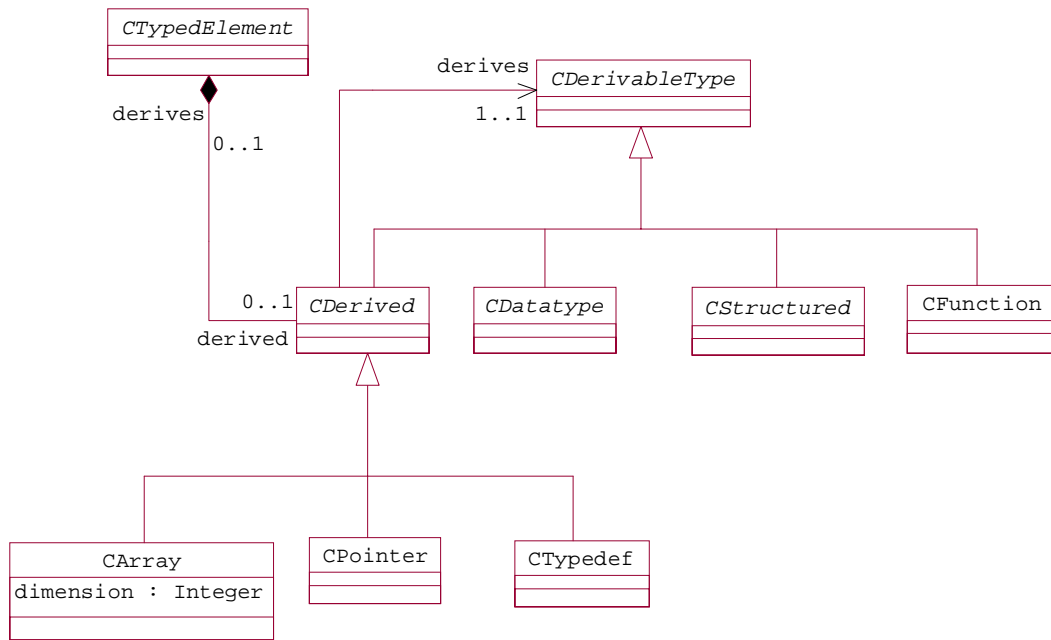

Figure 14-9 C Derivation

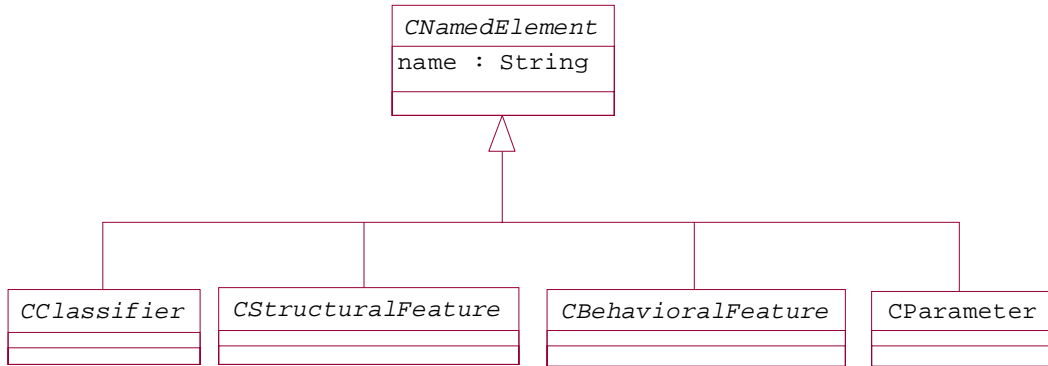

Figure 14-10 C Names

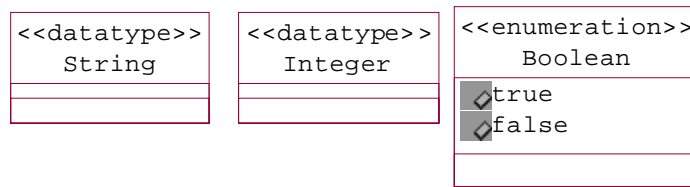

Figure 14-11 C Datatype - Model Types

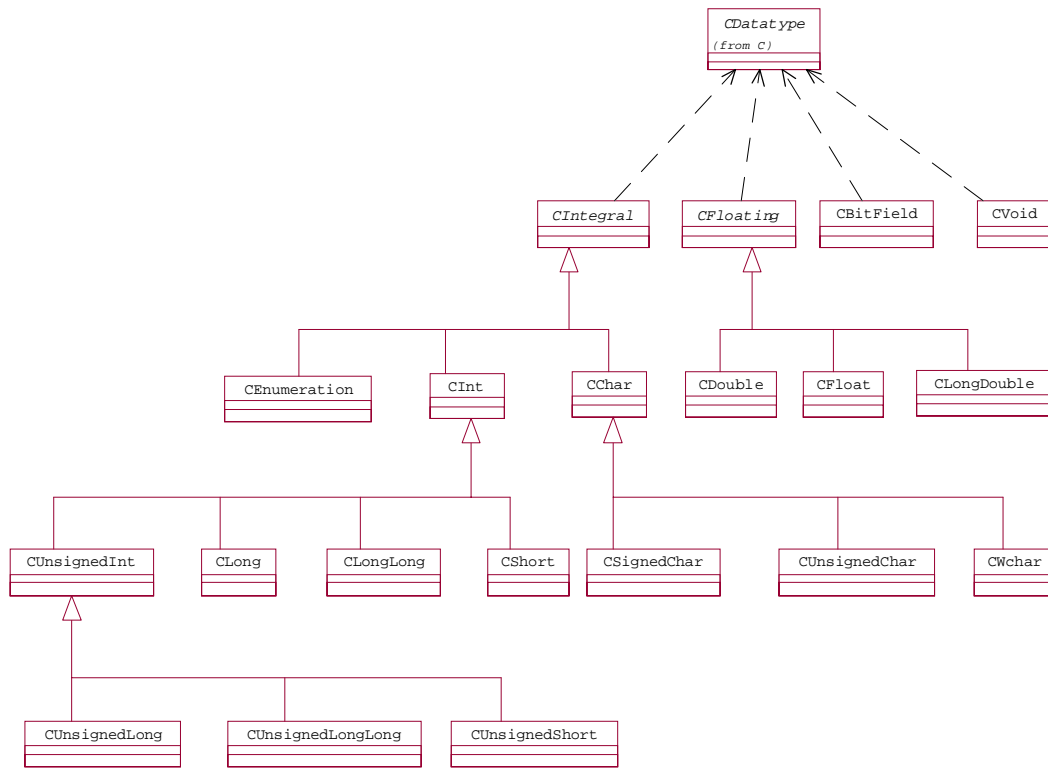

Figure 14-12 C User Types

14.3.1 C Metamodel Descriptions

14.3.1.1 CArray

CArray represents an ordered group of data objects. CArray refers to each object as an element. All elements within an array have the same data type.

14.3.1.2 CBehavioralFeature

CBehavioralFeature represents dynamic characteristics of the ModelElement that contains it. CBehavioralFeature is both a Feature and a Namespace. CBehavioralFeature serves as the parent of CFunction.

14.3.1.3 CClassifier

CClassifier represents all data types of the C metamodel. CClassifier is the parent class of C Derived types.

14.3.1.4 CDatatype

CDatatype represents data types and native types.

14.3.1.5 CDerivableType

CDerivableType represents datatypes which can be derived from CDatatype.

14.3.1.6 CDerived

CDerived represents datatypes derived from CDatatypes.

14.3.1.7 CField

CField represents attributes defined in an instance of the C metamodel.

14.3.1.8 CFunction

CFunction represents functions defined in an instance of the C metamodel.

14.3.1.9 CParameter

CParameter provides a means of communication with operations and CBehavioralFeature. A CParameter passes or communicates values of its defined type.

14.3.1.10 CPointer

CPointer represents a derived datatype declared as a pointer.

14.3.1.11 CSourceText

This class contains the entire source code (including comments) and its associated line number.

14.3.1.12 CStruct

CStruct represents a structure declared as type struct.

14.3.1.13 *CStructuralFeature*

CStructuralFeature represents static characteristics of the ModelElement that contains it. CStructuralFeature serves as the parent of CField.

14.3.1.14 *CStructureContents*

CStructureContents represent structured data types and structural features.

14.3.1.15 *CStructured*

CStructured is an abstract class that represents all structured data types of the C metamodel.

14.3.1.16 *CTypedef*

CTypedef represents a derived datatype declared as type typedef.

14.3.1.17 *CTypedElement*

CTypedElement represents data elements in the C metamodel.

14.3.1.18 *CUnion*

CUnion represents a structure declared as type union.

14.4 *C++ Metamodel*

The C++ metamodel, based on the ANNOTATED C++ REFERENCE MANUAL book (authors: Margaret A. Ellis, Bjarne Stoustrup), 1990, is a MOF Class instance at the M2 level. The C++ metamodel consists of C++ Main, and Model Types. This metamodel inherits from the C Main metamodel. The following figures illustrate the classes that constitute the C++ metamodel and show how the classes relate to each other. Following the diagrams is a brief explanation of what each class represents.

14.4.1.2 *CPPConst*

CPPConst represents data declared as a constant.

14.4.1.3 *CPPEextern*

CPPEextern represents a function declared in a C program that is called by the current C++ program. Declaring a function with the keyword 'extern' flags the C++ compiler not to generate an internal name for the function. As a result, functions declared extern may not be overloaded.

14.4.1.4 *CPPGeneralization*

CPPGeneralization represents the different types of generalizations available in a C++ class. Generalizations include associating a class with virtual inheritance.

14.4.1.5 *CPPMember*

CPPMember represents functions and variables that are prototyped and declared in a class definition. CPPMember includes members that are declared with any of the fundamental types, as well as other types, including pointer, reference, array types, and user-defined types.

14.4.1.6 *CPPOperation*

CPPOperation represents C++ functions. CPPOperation is a specialization of CFunction from the C Metamodel and provides additional features such as static declaration.

14.4.1.7 *CPPOperator*

CPPOperator represents basic operators such as add, subtract, and equals. C++ programmers have the option to override CPPOperators.

14.4.1.8 *CPPReference*

CPPReference represents a reference to an object. References are denoted by an ampersand (&) sign.

14.4.1.9 *CPPTemplate*

CPPTemplate represents a template which must define or declare one of the following:

A class

A function

A static member of a template class

Non-normative Enterprise Application Interface Metamodels

A

The application-domain interface metamodel describes signatures for input and output parameters and return types for enterprise application system domains. IBM's IMS Transaction Message, IMS Message Format Service (MFS), and CICS Basic Mapping Support (BMS) are examples of such metamodels. The payload of these interface metamodels typically carries application data destined for a program of a specific language. Therefore, it is important that these interface metamodels connect to the language metamodels, as shown in Figure 7-7 on page 7-22 in Section 7.3.9, "Physical Representation Model: Convergent Metamodel. The class in the interface metamodel which represents the signature of a message, associates to a language-independent interface class, TDLangElement, in order to be able to connect to any language metamodel. From TDLangElement navigations can be done between the Type Descriptor meta model and the language metamodel to perform type conversion, if necessary.

A.1 IMS Transaction Message Metamodel

IMS OTMA (Open Transaction Manager Access) is a transaction-based, connectionless client/server protocol within an OS/390 sysplex environment. An IMS OTMA transaction message consists of an OTMA prefix, plus message segments for input and output requests. Both input and output message segments contain llzz (i.e. length of the segment and reserved field), and application data. Only the very first input message segment will contain transaction code in front of the application data. IMS transaction application programs can be written in a variety of languages, e.g. COBOL, PL/ I, C, Java, etc. Therefore, the application data can be in any one of these languages.

IMS Transaction Message metamodel captures the metadata associated with sending and receiving messages to and from IMS transaction applications. ApplicationData class represents the payload message. Note that the payload message data can be both input and output data parameters. The following figures illustrate the classes that

constitute the IMS Transaction Message metamodel and show how the classes relate to each other. Following the diagrams is a brief explanation of what each class represents.

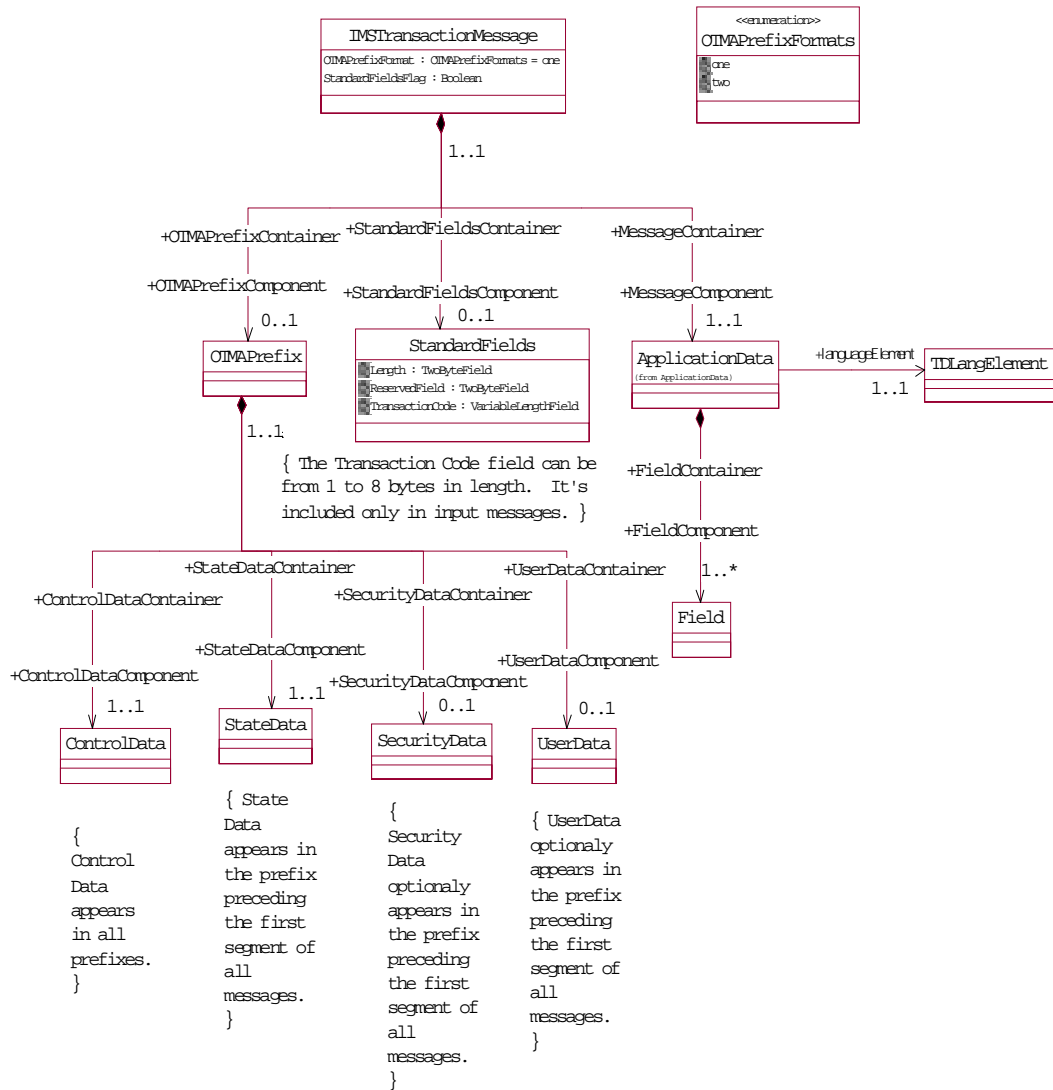

Figure A-1 IMS Transaction Message Metamodel

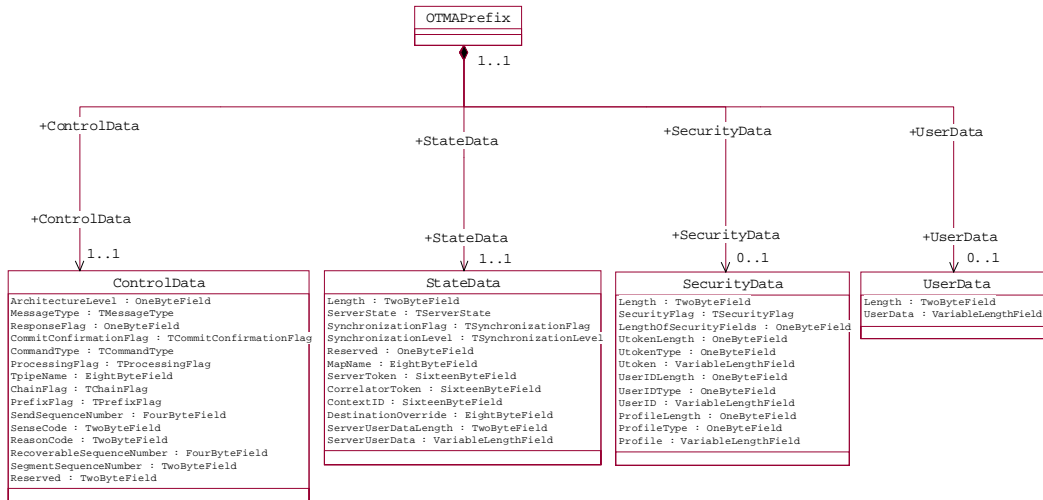

Figure A-2 IMS Transaction Message Prefix

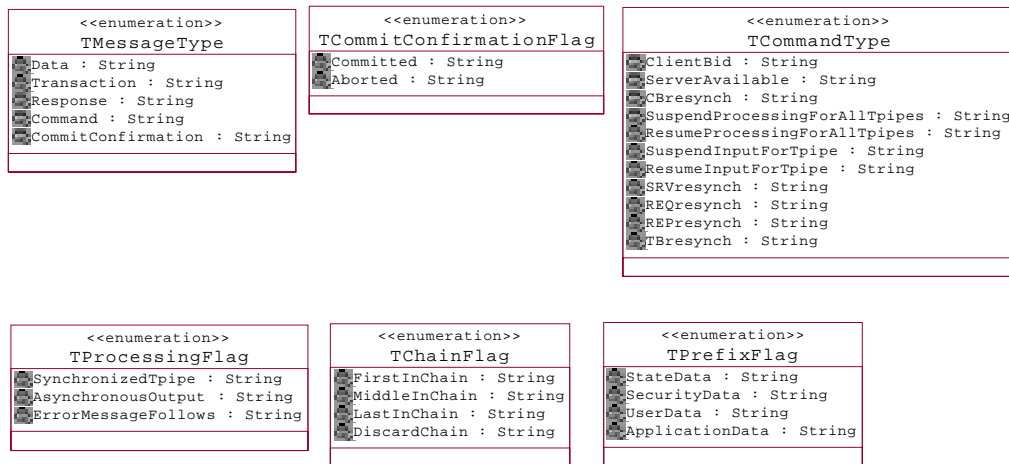

Figure A-3 OTMA Prefix - Defined Types

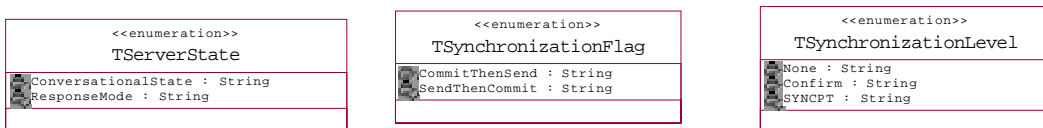

Figure A-4 OTMA Prefix - State Data Defined Types

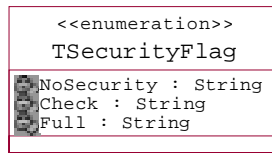

Figure A-5 OTMA Prefix - Security Data Defined Types



Figure A-6 IMS Messages Primitive Types

A.1.2 IMS Transaction Message Metamodel Descriptions

ApplicationData

The application data class contains all the message data except for LL, ZZ, and the transaction code. ApplicationData contains the signature of an IMS transaction message, which can include inputs, output, and return types. ApplicationData associates with TDLangElement, which provides the linkage to the language specific physical representation of the data that an ApplicationData represents.

Note – This model does not capture the notion of message segments. When using this model you have to bear in mind whether the system you are using has any limitations such as a maximum segment size. IMS "gateway" (via OTMA or SNA) must support the capability of breaking the "application data" into IMS message segments.

For instance, if you are sending this XML message directly to the IMS message queue and if the message queue has a 32k limit, then you have to take your XML message and break it up into 32k chunks. The application on IMS will then have to gather up the 32k chunks one by one. IMS new applications that receive XML documents directly, must be capable of receiving XML documents in multiple segments.

For ACK or NAK messages, there is no application data included in the message field. Each data field, defined in a copybook for the application data, will be associated with type descriptor for data types.

ControlData

ControlData is message-control information. It includes the transaction-pipe name, message type, sequence numbers, flags and indicators.

ControlData has the following private attributes:

- ArchitectureLevel is an OneByteField.

Specifies the OTMA architecture level. The client specifies an architecture level, and the server indicates in the response message which architecture level it is using. The architecture levels used by a client and a server must match.

With IMS Version 6, the only valid value is X'01'. It is mandatory for all messages.
- MessageType is TmessageType.

Specifies the message type. Every OTMA message must specify a value for the message type. The values are not mutually exclusive. For example, when the server sends an ACK message to a client-submitted transaction, both the transaction and response flags are set.
- ResponseFlag is OneByteField.

Specifies either that the message is a response message or that a response is requested.

Acknowledgments to transactions include attributes (for that transaction) in the application-data section of the message prefix only if the transaction specifies Extended Response Requested.
- CommitConfirmationFlag is TcommitConfirmationFlag.

Specifies the success of a commit request. Sent by the server to the client in a commit-confirmation message. These messages are only applicable for send-then-commit transactions, and are not affected by the synchronization-level flag in the state-data section of the message prefix.
- CommandType is TcommandType.

Specifies the OTMA protocol command type.

IMS commands are specified in the application-data section of the message.
- ProcessingFlag is TprocessingFlag.

Specifies options by which a client or a server can control message processing.
- TpipeName is EightByteField.

Specifies the transaction-pipe name. For IMS, this name is used to override the LTERM name on the I/O PCB. This field is applicable for all transaction, data, and commit-confirmation message types. It is also applicable for certain response and command message types.

- ChainFlag is TchainFlag.

Specifies how many segments are in the message. This flag is applicable to transaction and data message types, and it is mandatory for multi-segment messages.

- PrefixFlag is TprefixFlag.

Specifies the sections of the message prefix that are attached to the OTMA message. Every message must have the message-control information section, but any combination of other sections can be sent with an OTMA message.

- SendSequenceNumber is FourByteField.

Specifies the sequence number for a transaction pipe. This sequence number is updated by the client and server when sending message or transactions.

Recommendation: Increment the number separately for each transaction pipe.

This number can also be used to match an ACK or NAK message with the specific message being acknowledged.

- SenseCode is TwoByteField.

Specifies the sense code that accompanies a NAK message.

- ReasonCode is TwoByteField.

Specifies the reason code that accompanies a NAK message. This code can further qualify a sense code.

- RecoverableSequenceNumber is FourByteField.

Specifies the recoverable sequence number for a transaction pipe. Incremented each time a recoverable message is sent using a synchronized transaction pipe. Both the client and the server increment their recoverable send-sequence numbers and maintain them separately from the send-sequence number.

- SegmentSequenceNumber is TwoByteField.

Specifies the sequence number for a segment of a multi-segment message. This number must be updated for each segment, because messages are not necessarily delivered sequentially by XCF.

This number must have a value of 0 (zero) if the message has only one segment.

- Reserved is a TwoByteField.

IMSTransactionMessage

IMSTransactionMessage is the base class of the IMS transaction message metamodel which includes the following IMS messages scenarios:

- IMS OTMA messages with the OTMA prefix
- IMS OTMA messages without the OTMA prefix
- IMS basic messages to be sent to the application program directly

OTMAPrefix

An IMS OTMA prefix can appear either before all message segments, or only before the first segment of the message.

However, the OTMA prefix is optional. If it is not specified, the IMS gateway will build a default one for the request.

OTMAPrefixFormats

OTMAPrefixFormats has the following two types:

- Format "one": a prefix appears before all message segments.
- Format "two": a prefix appears only before the first message segment.

SecurityData

SecurityData includes the user ID, user token, and security flags.

The security-data section is mandatory for every transaction, and can be present for OTMA command messages.

SecurityData has the following private attributes:

- Length is TwoByteField.
Specifies the length of the security data section of the message prefix, including the length field.
- SecurityFlag is TsecurityFlag.
Specifies the type of security checking to be performed. It is assumed that the user ID and password are already verified.
- LengthOfSecurityFields is OneByteField.
Specifies the length of the security data fields: User ID, Profile, and Utoken. These three fields can appear in any order, or they can be omitted. Each has the following structure: Length field, then Field type, then Data field. The actual length of the User ID or Profile should not be less than the value specified for the length of each field.

Length can be 0.

-
- UtokenLength is OneByteField.
Specifies the length of the user token. Length does not include length field itself.
 - UtokenType is OneByteField.
Specifies that this field contains a user token. (Value X'00').
 - Utoken is VariableLengthField.
Specifies the user token. The user ID and profile are used to create the user token. The user token is passed along to the IMS dependent region.

If the client has already called FACF, it should pass the Utoken with field type X'00' so that RACF is not called again. Utoken is a variable length, from 1 to 80 bytes.
 - UserIDLength is OneByteField.
Specifies the length of the user ID. Length does not include length field itself.
 - UserIDType is OneByteField.
Specifies that this field contains a user ID. (Value X'02').
 - UserID is VariableLengthField.
Specifies the actual user ID. UserID is a variable length, from 1 to 10 bytes.
 - ProfileLength is OneByteField.
Specifies the length of the profile. Length does not include length field itself.
 - ProfileType is OneByteField.
Specifies that this field contains a profile. (Value X'03').
 - Profile is VariableLengthField.
Specifies the system authorization facility (SAF) profile. For RACF, this is the group name. Profile is a variable length, from 1 to 10 bytes.

StandardFields

StandardFields consist of LL, ZZ and transaction code. Transaction code appears with first segment of input messages only, and it comes after LL (length) and ZZ (reserved field). The transaction code field can be from 1 to 8 bytes in length.

StandardFields are not included in the following scenarios:

- Sending XML documents directly to the IMS transaction application programs
- ACK or NAK messages to IMS applications

StateData

StateData includes a destination override, map name, synchronization level, commit mode, tokens and server state.

StateData has the following private attributes:

- Length is a of type TwoByteField.
- ServerState is of type ServerState. It specifies the mode in which the transaction is running.
- SynchronizationFlag is of type TsynchronizationFlag. It specifies the commit mode of the transaction. This flag controls and synchronizes the flow of data between the client and server.
- SynchronizationLevel is of type TsynchronizationLevel. It specifies the transaction synchronization level, the way in which the client and server transaction program (for example, IMS application program) interacts with program output messages.

The default is Confirm. IMS always requests a response when sending commit-then-send output to a client.

- Reserved is OneByteField.
- MapName is EightByteField.

Specifies the formatting map used by the server to map output data streams (for example, 3270 data streams). Although OTMA does not provide MFS support, you can use the map name to define the output data stream. The name is an 8-byte MOD name that is placed in the I/O PCB. IMS replaces this field in the prefix with the map name in the I/O PCB when the message is inserted. The map name is optional.

- ServerToken is SixteenByteField.

Specifies the server name. The Server Token must be returned by the client to the server on response messages (ACKs or NAKs). For conversational transactions, the Server Token must also be returned by the client on subsequent conversational input.

- CorrelatorToken is SixteenByteField.

Specifies a client token to correlate input with output. This token is optional and is not used by the server.

Recommendation: Clients should use this token to help manage their transactions.

- ContextID is SixteenByteField.

Specifies the RRS/MVS token that is used with SYNCLVL=02 and protected conversations.

- DestinationOverride is EightByteField.

Specifies an LTERM name used to override the LTERM name in the IMS application program's I/O PCB. This override is used if the client does not want to override the LTERM name in the I/O PCB with the transaction-pipe name.

This optional override is not used if it begins with a blank.

- ServerUserDataLength is TwoByteField.

Specifies the length of the server user data, if any. The maximum length of the server use data is 256 bytes.

- ServerUserData is VariableLengthField.

Specifies any data needed by the server. If included in a transaction message by the client, it is returned by the server in the output data messages.

TChainFlag

TchainFlag has the following private attributes:

- FirstInChain (value X'80') specifies the first segment in a chain of segments, which comprise a multi-segment message. Subsequent segments of the message only need the message-control information section of the message prefix. Other applicable prefix segments (for example, those specified by the client on the transaction message) are sent only with the first segment (with the first-in-chain flag set).

If the OTMA message has only one segment, the last-in-chain flag should also be set.

- MiddleInChain (value X'40') specifies a segment that is neither first nor last in a chain of segments that comprise a multi-segment message. These segments only need the message-control information section of the message prefix.

Restriction: Because the client and server tokens are in the state-data section of the message prefix, they cannot be used to correlate and combine segmented messages. The transaction-pipe name and send-sequence numbers can be used for this purpose; they are in the message-control information section of the message prefix for each segment.

- LastInChain (value X'20') specifies the last segment of a multi-segment message.
- DiscardChain (value X'10') specifies that the entire chain of a multi-segment message is to be discarded. The last-in-chain flag must also be set.

TCommandType

TcommandType has the following private attributes:

- ClientBid (value X'04') specifies the first message a client sends to the OTMA server. This command must also set the response-requested flag and the security flag in the message-control information section of the message prefix. The appropriate stat-data fields (for example, Member Name) must also be set.
- The security-data prefix must specify a Utoken field so the OTMA server can validate the client's authority to act as an OTMA client.

Because the server can respond to the client-bid request, this message should not be sent until the client is ready to start accepting data messages.

-
- ServerAvailable (value X'08') specifies the first message the server sends to a client. It is sent when the server has connected to the XCF group before the client has connected. The client replies to the server Available message with a client-bid request. The appropriate state data fields (for example, Member Name) must also be set.

If the client connects first, it is notified by XCF when the server connects, and begins processing with a client-bid request.

- CBresynch (value X'0C') specifies a client-bid message with a request by the client for resynchronization. This command is optional and causes the server to send an SRVresynch message to the client. The CBresynch command is the first message that a client sends to the OTMA server when it attempts to resynchronize with IMS and existing synchronized Tpipes exist for the client. Other than the CBresynch message indicator in the message prefix, the information required for the message prefix should be identical to the client-bid command.

If IMS receives a client-bid request for them client and IMS is aware of existing synchronized Tpipes, IMS issues informational message DFS2394I to the MTO. IMS resets the recoverable send- or receive- sequence numbers to 0 (zero) for all the synchronized Tpipes.

- SuspendProcessingForAllTpipes (value X'14') specifies that the server is suspending all message activity with the client. All subsequent data input receives a NAK message from the server. Similarly, the client should send a NAK message for any subsequent server messages. If a client wishes to suspend processing for a particular transaction pipe, it must submit a /STOP TPIPE command as an OTMA message.
- ResumeProcessingForAllTpipes (value X'18') specifies that the server is resuming message activity with the client. If a client wishes to resume processing for a particular transaction pipe that has been stopped, it must submit a /START TPIPE command as an OTMA message.
- SuspendInputForTpipe (value X'1C') specifies that the server is overloaded and is temporarily suspending input for the transaction pipe. All subsequent client input receive NAK messages for the transaction pipe specified in the message-control information section of the message prefix. A response is not requested for this command.
- This architected command is also sent by IMS when the master terminal operator enters a /STOP TPIPE command.
- ResumeInputForTpipe (value X'20') specifies that the server is ready to resume client input following an earlier Suspend Input for Tpipe command. A response is not requested for this command.

This command is also sent by IMS when the IMS master terminal operator issues a /START TPIPE command.

- SRVresynch (value X'2C') specifies the server's response to a client's CBresynch command. This command specifies the states of synchronized transaction pipes within the server (the send- and receive-sequence numbers).

This command is sent as a single message (with single or multiple segments), and an ACK is requested.

- REQresynch (value X'30') specifies the send-sequence number and the receive sequence for a particular Tpipe. REQresynch is sent from IMS to a client.
- REPresynch (value X'34') specifies the client's desired state information for a Tpipe. A client sends the REPresynch command to IMS in response to the REQresynch command received from IMS.
- TBresynch (value X'38') specifies that the client is ready to receive the REQresynch command from IMS.

TCommitConfirmationFlag

TcommitConfirmationFlag has the following private attributes:

- Committed (value X'80') specifies that the server committed successfully.
- Aborted (value X'40') specifies that the server aborted the commit.

TMessageType

TmessageType has the following private attributes:

- Data (value X'80') specifies server output data sent to the client. If the client specifies synchronization level Confirm in the state-data section of the message prefix, the server also sets Response Requested for the response flag. If the client does not specify a synchronization level, the server uses the default, Confirm.
- Transaction (value X'40') specifies client input data to the server.
- Response (value X'20') specifies that the message is a response message, and is only set if the message for which this message is the response specified Response Requested for the response flag. If this flag is set, the response flag specifies either ACK or NAK.
- The send-sequence numbers must match for the original data message and the response message. Chained transaction input messages to the server must always request a response before the next transaction (for a particular transaction pipe) is sent.
- Command (value X'10') specifies an OTMA protocol command. OTMA commands must always specify Response Requested for the Response flag.
- CommitConfirmation (value X'08') specifies that commit is complete. This is sent by the server when a sync point has completed, and is only applicable for send-then-commit transactions. The commit-confirmation flag is also set.

TPrefixFlag

TPrefixFlag has the following attributes:

-
- StateData (value X'80') specifies that the message includes the state-data section of the message prefix.
 - SecurityData (value X'40') specifies that the message includes the security-data section of the message prefix.
 - UserData (value X'20') specifies that the message includes the user-data section of the message prefix.
 - ApplicationData (value X'10') specifies that the message includes the application-data section of the message prefix.

TProcessingFlag

TprocessingFlag has the following private attributes:

- SynchronizedTpipe (value X'40') specifies that the transaction pipe is to be synchronized. Allows the client to resynchronize a transaction pipe if there is a failure. Only valid for commit-then-send transactions.

This flag causes input and output sequence numbers to be maintained for the transaction pipe. All transactions routed through the transaction pipe must specify this flag consistently (either on or off).

- AsynchronousOutput (value X'20') specifies that the server is sending unsolicited queued output to the client. This can occur when IMS inserts a message to an alternate PCB. Certain IMS commands, when submitted as commit-then-send, can cause IMS to send the output to a client with this flag set. In this case, the OTMA prefixes contain no identifying information that the client can use to correlate the output to the originating command message. These command output data messages simply identify the transaction-pipe name. IMS can also send some unsolicited error messages with only the transaction-pipe name.
- ErrorMessageFollows (value X'10') specifies that an error message follows this message. This flag is set for NAK messages from the server. An additional error message is then sent to the client.

The asynchronous-output flag is not set in the error data message, because the output is not generated by an IMS application.

TResponseFlag

TResponseFlag has the following private attributes:

- ACK (value X'80') specifies a positive acknowledgment.
- NAK (value X'40') specifies a negative acknowledgment.
- ResponseRequested (value X'20') specifies that a response is requested for this message. This can be set for message types of Data, Transaction, or Command.
- When sending send-then-commit IMS command output, IMS does not request an ACK regardless of the synchronization level.

-
- ExtendedResponseRequested (value X'10') specifies that an extended response is requested for this message. Can be set by a client only for transactions (or for transactions that specify an IMS command instead of a transaction code).
 - If this flag is set for a transaction, IMS returns the architected attributes for that transaction in the application-data section of the ACK message.
 - If this flag is set for a command, IMS returns the architected attributes in the application-data section of the ACK message. This flag can be set for the IMS commands /DISPLAY TRANSACTION and /DISPLAY TRANSACTION ALL.

TSecurityFlag

TSecurityFlag has the following attributes:

- NoSecurity (value X'N') specifies that no security checking is to be done.
- Check (value X'C') specifies that transaction and command security checking is to be performed.
- Full (value X'F') specifies that transaction, command, and MPP region security checking is to be performed.

TServerState

TServerState has the following private attributes:

- ConversationalState (value X'80') specifies a conversational mode transaction. The server sets this state when processing a conversational-mode transaction. This state is also set by the client when sending subsequent IMS conversational data messages to IMS.
- ResponseMode (value X'40') specifies a response-mode transaction. Set by the server when processing a response-mode transaction.

This state has little significance for an OTMA server, because OTMA does not use sessions or terminals.

TSynchronizationFlag

TSynchronizationFlag has the following private attributes:

- CommitThenSend (value X'40') specifies a commit-then-send transaction. The server commits output before sending it; for example, IMS inserts the output to the IMS message queue.
- SendThenCommit (value X'20') specifies a send-then-commit transaction. The server sends output to the client before committing it.

TSynchronizationLevel

TSynchronizationLevel has the following private attributes:

-
- None (value X'00') specifies that no synchronization is requested. The server application program does not request an ACK message when it sends output to a client.
 - None is only valid for send-then-commit transactions.
 - Confirm (value X'01') specifies that synchronization is requested. The server sends transaction output with the response flag set to Response Requested in the message-control information section of the message prefix.

Confirm can be used for either commit-then-send or send-then-commit transactions.

- SYNCPT (value X'02') specifies that the programs participate in coordinated commit processing on resources updated during the conversion under the RRS/MVS recovery platform. A conversation with this level is also called a protected conversation.

UserData

UserData includes any special information needed by the client. The user-data section is variable length and follows the security-data section of the message prefix. It can contain any data.

UserData has the following attributes:

- Length is a TwoByteField.

Specifies the length of the user-data section of the message prefix, including the length field. The maximum length of the user data is 1024 bytes.

- UserData is a VariableLengthField.

Specifies the optional user data. This data is managed by the client, and can be created and updated using the DFSYDRU0 exit routine. The server returns this section unchanged to the client as the first segment of any output messages.

A.2 IMS MFS Metamodel

Today there are many IMS application programs which run crucial business processes. Many of these IMS programs are based on IMS's message format service (MFS). MFS is a facility of the IMS Transaction Manager environment that formats messages to and from terminal devices. As these business processes are updated to exploit new business-to-business (B2B) technologies, there is a requirement for an easy and effective method of upgrading MFS applications with e-business capabilities. What is needed is the ability to send and receive IMS transaction messages, including MFS messages, as XML documents.

The MFS language utility processes MFS source, generates IMS control blocks, in a proprietary format, known as Message Input/Output Descriptors (MID/MOD) and Device Input/Output Format (DIF/DOF), and places them in an IMS Format Library. MFS supports several terminal types, including 3270s and VTAM LU1s using SCS, it was designed so that the IMS application programs using MFS do not themselves have to deal with any device-specific characteristics in the input or output messages.

Because MFS provides headers, page numbers, operator instructions, and other literals to the device, the application's input and output messages can be built without having to pass these format literals. MFS identifies all fields in the message response and formats these responses according to the specific device type that is the target for the response. This allows application programmers to concentrate their efforts on the business logic of the program.

Because the IMS application program I/O data structures do not fully describe the end user interaction with these existing MFS applications, a way is needed to deal with the information that is buried within various MFS statements. Important examples of this kind of information are 3270 screen attribute bytes and PFKey input data. PFKeys can have significant semantic meaning for an application; it can even be used to initiate transactions. Many IMS application programs are passed PFKey data in input messages, but no application logic is required to recognize that a certain PFkey was pressed and therefore must be inserted into the input message. This is because, at runtime, it is the MFS online processing and not the application that places the literal that corresponds to the PFKey pressed into the appropriate field in the input message.

The IMS MFS metamodel, modeled from the MFS source, captures certain services or functions currently provided by MFS. Examples of such services or functions are PF keys, logical pages, predefined literals, and attribute bytes.

Note that the MFS metamodel supports the following device types:

- 3270 and 3270-An
- 3270P

The following device types are not supported:

- 2740 or 2741
- 3600 or 4700
- FIN
- FIDS, FIDS3, FIDS4 or FIDS7
- FIJP, FIPB or FIFP
- SCS1
- SCS2
- DPM-An
- DPM-Bn

The MFS metamodel does not support the following MFS statements:

- EJECT
- PD
- PDB
- PDBEND
- PPAGE (partial support, see DFLD)

- PRINT
- RCD
- SPACE
- TITLE

MFSMessageField identifies the signature of an IMS FMS message, which can include both inputs and outputs. MFSMessageField associates with TDLangElement, which provides the linkage to the language and platform specific representations of the data. The following figures illustrate the classes that constitute the IMS MFS metamodel and show how the classes relate to each other. Following the diagrams is a brief explanation of what each class represents.

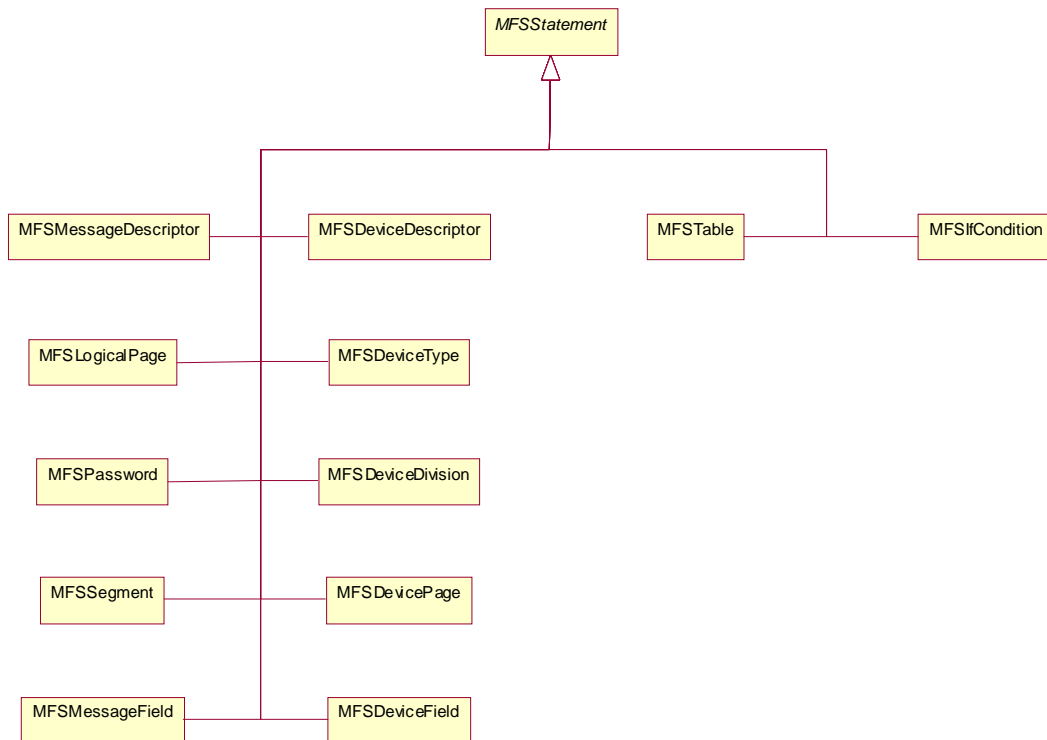

Figure A-7 MFS Inheritance View

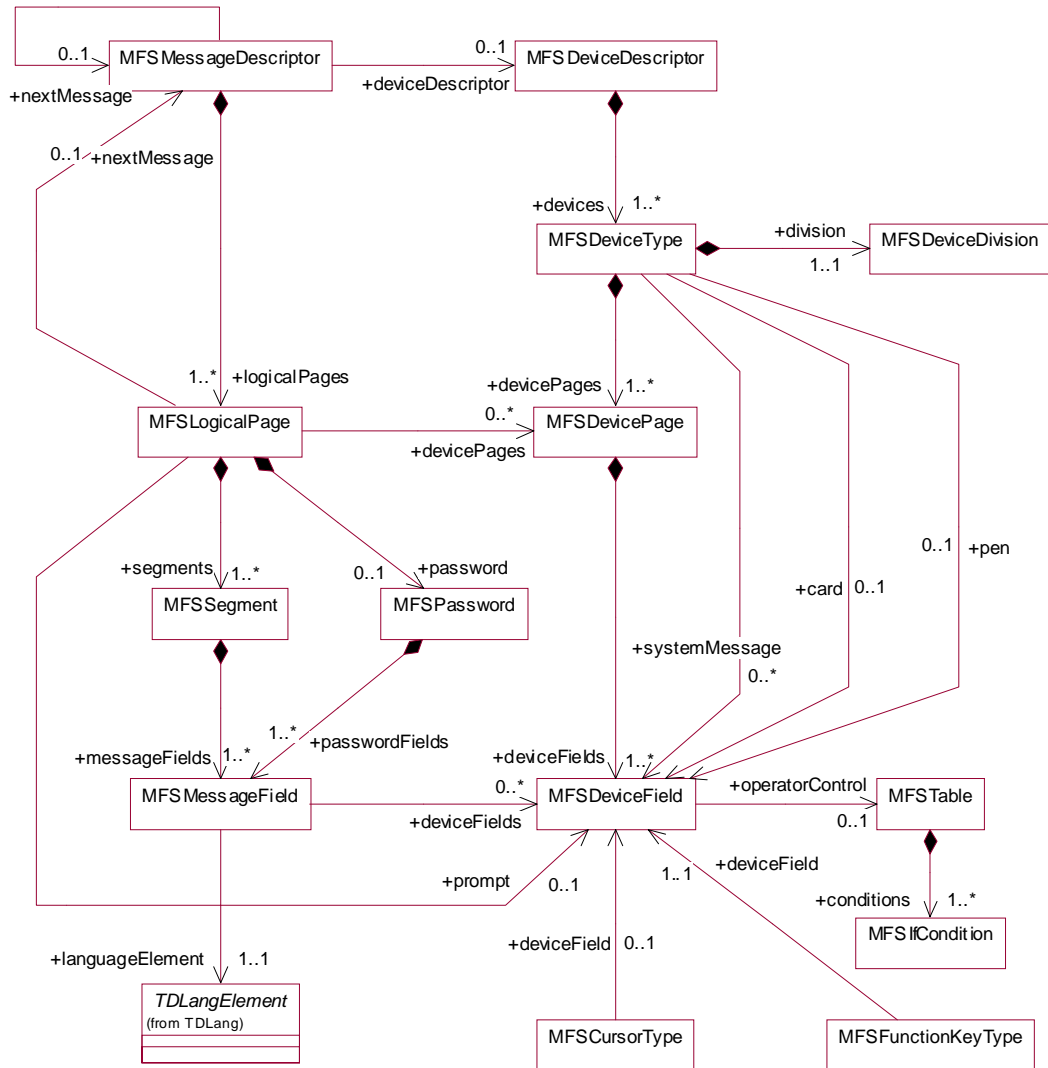

Figure A-8 MFS Relationship View

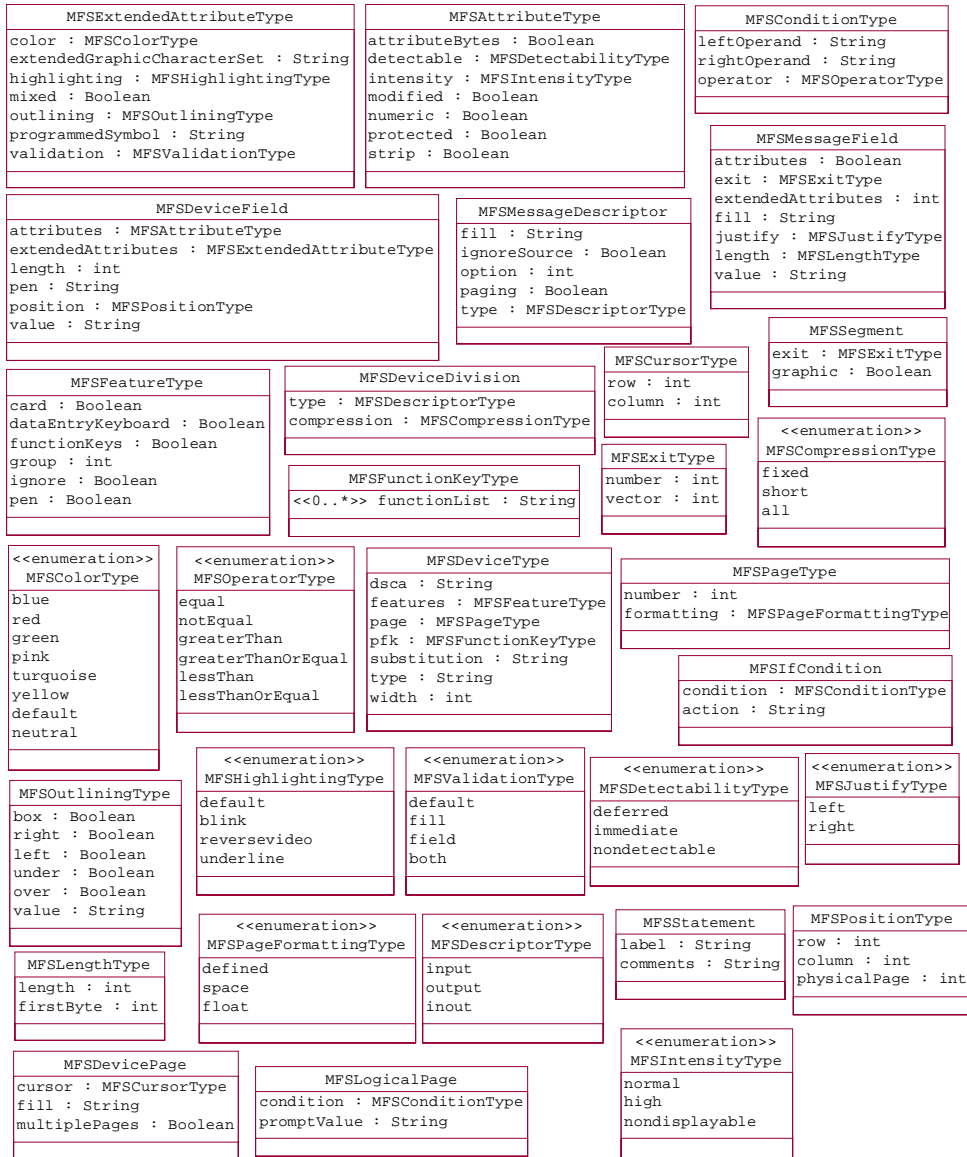

Figure A-9 MFS Attribute View

A.1.3 IMS MFS Metamodel Descriptions

MFSDeviceDescriptor

This class encapsulates the MFS "FMT" statement.

The FMT statement initiates and names a format definition that includes one or more device formats differing only in the device type and features specified in the DEV statement. Each device format included in the format definition specifies the layout for data sent to or received from a device or a remote program. All attributes are supported

MFSDeviceDivision

This class encapsulates the MFS "DIV" statement.

The DIV statement defines device formats within a DIF or DOF. The formats are identified as input, output, or both input and output, and can consist of multiple physical pages. Only one DIV statement per DEV is allowed.

The MFS metamodel does not support the following DIV attributes:

- RCDCTL
- HDRCTL
- OPTIONS
- OFTAB
- DPN
- PRN
- RDPN
- RPRN

type : MFSDescriptorType

TYPE attribute.

Describes an input only format (INPUT), an output only format (OUTPUT), or both (INOUT).

If DIV TYPE=OUTPUT or TYPE=INPUT is specified, certain DEV statement keywords are applicable.

compression : MFSCompressionType

COMPR attribute.

Requests MFS to remove trailing blanks from short fields, fixed-length fields, or all fields presented by the application program.

MFSDeviceField

This class encapsulates the MFS "DFLD" statement.

The DFLD statement defines a field within a device format, which is read from or written to a terminal or remote program. Only those areas, which are of interest to the IMS or remote application program should be defined. Null space in the format does not need to be defined. The SLD attribute is not supported.

attributes : MFSAtributeType

ATTR attribute.

extendedAttributes : MFSExtendedAttributeType

EATTR attribute.

length : int

LTH attribute.

Specifies the length of the field. This operand should be omitted if 'literal' is specified in the positional parameter, in which case the length of literal is used as the field length. Unpredictable formatting output can occur if this operand is used in conjunction with a 'literal' and the two lengths are different. The specified LTH= cannot exceed the physical page size of the device.

The maximum allowable length for all devices except 3270, 3604 display, and DPM with RCDCT=NOSPAN is 8000 characters. For 3270 displays, the maximum length is one less than screen size. For example, for a 480-character display, the maximum length is 479 characters. A length of 0 must not be specified. If SCA and LTH= are both specified, LTH must be 2.

POS= and LTH= do not include the attribute character position reserved for a 3270 display device or a DFLD with ATTR=YES specified. The inclusion of this byte in the design of display/printer formats is necessary because it occupies the screen/printed page position preceding each displayed/printed field even though it is not accessible by an application program.

When defining DFLDs for 3270 printers, a hardware ATTRIBUTE character is not used. Therefore, fields must be defined with a juxtaposition that does not allow for the attribute character unless ATTR=YES is specified. However, for printers defined as 3270P the last column of a print line (based onFEAT=, WIDTH=, or the device default width) cannot be used. The last column of the line is reserved for carriage control operations performed by IMS. Thus, if the print line specifies 120 (FEAT=120) and the DFLD specifies POS=(1,1),LTH=120 then 119 characters are printed on line 1 and one character on line 2.

Detectable fields (DET or IDET) must include four positions in POS and LTH for a 1-byte detection designator character and 3 pad characters, unless the detectable field is the last field on a display line, in which case only one position for the detection designator character is required. The detection designator character must precede field data, and pad characters (if required) follow field data. Detection designator and

required pad characters must be supplied by the application program or MFLD literal with the field data. Pad characters can also be required in the preceding field on the device.

pen : String

PEN attribute.

Specifies a literal to be selected or an operator control function to be performed when this field is detected. If (1) 'literal' is specified, (2) the field is defined as immediately detectable (ATTR= operand), and (3) contains the null or space designator character, the specified literal is placed in the field referred to by the PEN operand of the preceding DEV statement when the field is detected (if no other device fields are modified). If another field on the device is modified, a question mark (?) is provided instead of the literal. Literal length must not exceed 256 bytes.

If (1) a control function is specified, (2) the field is defined as immediately detectable (ATTR= operand), and (3) contains the null or space designator character, the specified control function is performed when the field is detected and no other device fields are modified. If another field on the device is modified, a question mark (?) is provided and the function is not performed. Control functions that can be specified are:

- NEXTTP--PAGE ADVANCE specifies a request for the next physical page in the current output message. If no output message is in progress, no explicit response is made.
- NEXTMSG--MESSAGE ADVANCE specifies a request to dequeue the output message in progress (if any) and to send the next output message in the queue (if any).
- NEXTMSGP--MESSAGE ADVANCE PROTECT specifies a request to dequeue the output message in progress (if any), and send the next output message or return an information message indicating that no next message exists.
- NEXTLP--NEXT LOGICAL PAGE specifies a request for the next logical page of the current message.
- ENDMPP--END MULTIPLE PAGE INPUT specifies the end of a multiple physical page input message.
- ENDMPP is valid only if data has been received and will not terminate multiple page input (MPPI) in the absence of data entry.

position : MFSPositionType

POS attribute.

Defines the first data position of this field in terms of line (lll), column (ccc), and physical page (pp) of the display format. If pp is omitted, 1 is assumed.

For DEV TYPE=3270, 3270-An, or 3270P:

- lll,ccc,pp specifies the line, column, and optionally, the physical page number for an output field. lll, ccc, and pp must be greater than or equal to 1.

-
- For 3270 displays, POS=(1,1) must not be specified. Fields must not be defined such that they wrap from the bottom to the top.

Restriction: On some models of 3270s, the display screen cannot be copied when a field starting on line 1, column 2, has both alphabetic and protect attributes.

value : String

The default value of the device field.

MFSDevicePage

This class encapsulates the MFS "DPAGE" statement.

The DPAGE statement defines a logical page of a device format. This statement can be omitted if none of the message descriptors referring to this device format (FMT) contains LPAGE statements and if no specific device option is required. It is implied if not present.

The MFS metamodel does not support the following DPAGE attributes:

- ACTVPID
- COND
- OFTAB
- ORIGIN
- PD
- SELECT

cursor : MFSCursorType

CURSOR attribute.

Specifies the position of the cursor on a physical page. Multiple cursor positions may be required if a logical page or message consists of multiple physical pages. The value lll specifies line number, ccc specifies column; both lll and ccc must be greater than or equal to 1. The cursor position must either be on a defined field or defaulted. The default lll,ccc value for 3270 displays is 1,2. For Finance display components, if no cursor position is specified, MFS will not position the cursor--the cursor is normally placed at the end of the output data on the device. For Finance display components, all cursor positioning is absolute, regardless of the ORIGIN= parameter specified.

The dflld parameter provides a method for supplying the application program with cursor information on input and allowing the application program to specify cursor position on output.

Recommendation: Use the cursor attribute facility (specify ATTR=YES in the MFLD statement) for output cursor positioning.

The `dfld` parameter specifies the name of a field containing the cursor position. This name may be referenced by an `MFLD` statement and must not be used as the label of a `DFLD` statement in this `DEV` definition. The format of this field is two binary halfwords containing line and column number, respectively. When this field is referred to by a message input descriptor, it will contain the cursor position at message entry. If referred to by a message output descriptor, the application program places the desired cursor position into this field as two binary halfwords containing line and column, respectively. Binary zeros in the named field cause the specified `lll,ccc` to be used for cursor positioning during output. During input, binary zeros in this field indicate that the cursor position is not defined. The input `MFLD` referring to this `dfld` should be defined within a segment with `GRAPHIC=NO` specified or should use `EXIT=(0,2)` to convert the binary numbers to decimal.

fill : String

FILL attribute.

Specifies a fill character for output device fields. Default value for all device types except the 3270 display is `X'40'`; default for the 3270 display is `PT`. For 3270 output when `EGCS` fields are present, only `FILL=PT` or `FILL=NULL` should be specified. A `FILL=PT` erases an output field (either a 1- or 2-byte field) only when data is sent to the field, and thus does not erase the `DFLD` if the application program message omits the `MFLD`.

- `NONE` must be specified if the fill character from the message output descriptor is to be used to fill the device fields.
- `X'hh'` character whose hexadecimal representation is `'hh'` will be used to fill the device fields.
- `C'c'` character `'c'` will be used to fill the device fields.
- `NULL` specifies that fields are not to be filled. For devices other than the 3270 display, 'compacted lines' are produced when message data does not fill the device fields.
- `PT` specifies that output fields that do not fill the device field (`DFLD`) are followed by a program tab character to erase data previously in the field; otherwise, this operation is identical to `FILL=NULL`.

For 3270 display devices, any specification with a value less than `X'3F'` is changed to `X'00'` for control characters or to `X'40'` for other non-graphic characters.

multiplePages : Boolean

MULT attribute.

Specifies that multiple physical page input messages will be allowed for this `DPAGE`.

MFSDeviceType

This class encapsulates the MFS "DEV" statement.

The DEV statement defines device characteristics for a specific device or data formats for a specific device type. The DFLD statements following this DEV statement are mapped using the characteristics specified until the next DEV or FMTEND statement is encountered.

The MFS metamodel does not support the following DEV attributes:

- ERASE
- FTAB
- FORMS
- HT
- HTAB
- LDEL
- MODE
- SLD
- VERSID
- VT
- VTAB

card : 0..1 MFSDDeviceField

CARD attribute.

Defines the input field name to receive operator identification card data when that data is entered. This name can be referenced by an MFLD statement and must not be used as the label of a DFLD statement within this DEV definition. This operand is valid only if a 3270 display is specified. If FEAT=NOCD is specified for a 3270 display, it is changed to CARD. All control characters are removed from magnetic card input before the data is presented to the input MFLD that refers to this card field name.

For 3270 displays, an unprotected field large enough to contain the magnetic card data and control characters must be defined through a DFLD statement. Position the cursor to this field and insert the card in the reader to enter card information. The card data is logically associated with the CARD= field name, not the name used in the DFLD statement.

dscs : String

DSCA attribute.

Specifies a default system control area (DSCA) for output messages using this device format. The DSCA supersedes any SCA specified in a message output descriptor if there are conflicting specifications. Normally, the functions specified in both SCAs are performed. If the DSCA= operand is specified for 3270P, it is ignored, except for the bit setting for "sound device alarm." If this bit is specified on the DSCA/SCA option, it is sent to the device.

The value specified here must be a decimal number not exceeding 65535 or X'hhhh'. If the number is specified, the number is internally converted to X'hhhh'.

If byte 1 bit 5 is set to B'1' (unprotect screen option) for a 3275 display, and both input and output occur simultaneously (contention), the device is disconnected. For non-3275 devices, the SCA option is ignored. If byte 1 bit 5 is set to B'0', the application program can request autopaged output by setting the SCA value to B'1'. This request is honored only if present in the first segment of the first LPAGE of the output message.

If a nonzero value is specified for byte 0, or for bit 6 or 7 in byte 1, MFS overrides the specified value with zero.

features : MFSFeatureType

FEAT attribute.

Specifies features for this device or program group. Possible features are:

- IGNORE specifies that device features are to be ignored for this device.
- 120|126|132 specifies line length for 3284, and 3286 device types (TYPE=3270P).
- CARD specifies that the device has a 3270 operator identification card reader. NOCD specifies the absence of the CARD feature.
- DEKYBD specifies data entry keyboard feature. This feature implies PFK feature; therefore, PFK is invalid if DEKYBD is specified. NOPFK implies the absence of PFK and DEKYBD features.
- PFK specifies that the device has program function keys. NOPFK specifies the absence of the PFK and DEKYBD features.
- PEN specifies the selector light pen detect feature. NOPEN specifies the absence of the PEN feature.
- 1|2|3|4|5|6|7|8|9|10 specifies customer-defined features for the 3270P device type.

For 3270P devices, FEAT= allows grouping of devices with special device characteristics. For example, FEAT=1 could group devices with a maximum of 80 print positions and no VFC, and FEAT=2 could group devices with 132 print positions and the VFC feature. FEAT=IGNORE should be specified to group together devices with a minimum set of device capabilities. When WIDTH= is specified, FEAT=(1...10) must also be specified. If FEAT=(1...10) is specified but WIDTH= is not specified, WIDTH= defaults to 120.

When IGNORE is specified, no other values should be coded in the FEAT= operand. When FEAT=IGNORE is not specified in the TERMINAL macro during system definition, the MSG statement must specify IGNORE in the SOR= operand for the device format with the IGNORE specification. Unless FEAT=IGNORE is used, FEAT= must specify exactly what was specified in the TERMINAL macro during IMS system definition. If it does not, the DFS057 error message is issued. When FEAT=IGNORE or 1-10 is specified for 3270 devices, the operands PEN=, CARD=, and PFK= can still be specified. When TYPE=3270P and FEAT=IGNORE, MFS allows a line width of 120 characters.

CARD, PFK, DEKYBD, and PEN feature values are valid only for 3270 displays. If the FEAT= operand is omitted, the default features are CARD, PFK, and PEN for 3270 displays; the default line width is 120 for TYPE=3270P.

1, 2, 3, 4, 5, 6, 7, 8, 9, and 10 are valid values only for 3270, 3270P and 3270-An. For 3270 displays, the FEAT= specifications of 1 to 5 can be used to group devices with specific features or hardware data stream dependencies.

Restriction: This keyword is optional and cannot be used with any other feature specification for 3270 displays.

Feature operand values can be specified in any order, and only those values desired need be specified. The underlined values do not have to be specified because they are defaults. Only one value in each vertical list can be specified.

page : MFSPageType

PAGE attribute.

Specifies output parameters as follows:

- number: For printer devices, number defines the number of print lines on a printed page; for card devices, number defines the number of cards to be punched per DPAGE or physical page (if pp parameter is used in the DFLD statements). This value is used for validity checking. The number specified must be greater than or equal to 1 and less than 256. The default is 55.
- DEFN specifies that lines/cards are to be printed/punched as defined by DFLD statements (no lines/cards are to be removed or added to the output page).
- SPACE specifies that each output page contains the exact number of lines/cards specified in the number parameter.
- FLOAT specifies that lines/cards with no data (all blank or NULL) after formatting are to be deleted.
- For 3270P devices, some lines having no data (that is, all blank or null) must not be deleted under the following circumstances:
 - The line contains one or more set line density (SLDx=) specifications.
 - A field specified as having extended attributes spans more than one line.

pen : 0..1 MFSDeviceField

PEN attribute.

Defines an input field name to contain literal data when an immediate light pen detection of a field with a space or null designator character occurs. The literal data is defined on the DFLD statement with the PEN= operand. (See PEN= operand on the DFLD statement.) This name can be referred to by an MFLD statement and must not be used as the label of a DFLD statement within this DEV definition. The PEN= operand is valid only for 3270 displays. If FEAT=NOOPEN is specified, it is changed to PEN.

If an immediate detect occurs on a field defined with a space or null designator character, and either another field has been selected or modified or has the MOD attribute, or the PEN= operand is not defined for the DFLD, a question mark (?) is inserted in the PEN= field name.

If no immediate detection occurs or the immediate detect occurs on a field defined with an ampersand (&) designator character, the PEN= operand is padded with the fill specified in the MFLD statement.

pfk : MFSFunctionKeyType

PFK attribute.

Defines an input field name to contain program function key literal or control function data (first subparameter) and, in positional or keyword format, either the literal data to be placed in the specified field, or the control function to be performed when the corresponding function key is entered (remaining subparameters).

The name of the first subparameter (the input field name that will contain the program function key literal or control function data) can be referred to by an MFLD statement and must not be used as the label of a DFLD statement within this DEV definition. The remaining subparameters can be specified in positional or keyword format. If the subparameters are in keyword format, the integer specified must be from 1 to 36, inclusive, and not duplicated. Only one PFK= operand format (positional or keyword) can be specified on a DEV statement. This operand is valid only for 3270 displays. At the time the actual format blocks are created, each literal is padded on the right with blanks to the length of the largest literal in the list. The maximum literal length is 256 bytes.

If the device supports the IMS copy function, then PFK12 invokes the copy function and the definition of PFK12 in the DEV statement is ignored; otherwise, the definition of PFK12 is honored.

If FEAT=NOPFK is specified, it is changed to PFK. The maximum number of user-defined PFKs is 36.

Control functions that can be specified are:

- NEXTTP--PAGE ADVANCE specifies a request for the next physical page in the current output message. If no output message is in progress, no explicit response is made.
- NEXTMSG--MESSAGE ADVANCE specifies a request to dequeue the output message in progress (if any) and to send the next output message in the queue (if any).
- NEXTMSGP--MESSAGE ADVANCE PROTECT specifies a request to dequeue the output message in progress (if any), and send the next output message or return an information message indicating that no next message exists.
- NEXTLP--NEXT LOGICAL PAGE specifies a request for the next logical page of the current message.

-
- ENDMPPPI--END MULTIPLE PAGE INPUT specifies the end of a multiple physical page input message.

substitution : String

SUB attribute.

Specifies the character used by MFS to replace any X'3F' characters in the input data stream. No translation occurs if this parameter is specified as X'3F' or this parameter is not specified, or the input received bypasses MFS editing. The specified SUB character should not appear elsewhere in the data stream; therefore, it should be non-graphic.

- X'hh' character whose hexadecimal representation is 'hh' replaces all X'3F' in the input data stream.
- C'c' character 'c' replaces all X'3F' in the input data stream.

systemMessage : 0..* MFSDeviceField

SYSMSG attribute.

Specifies the label of the DFLD statements that define the device field in which IMS system messages are to be displayed. This operand is valid only if a 3270 display is specified. A DFLD with this label should be defined for each physical page within each DPAGE defined within this DEV definition. DFLDs for SYSMSG should be at least LTH=79 to prevent message truncation. The referenced DFLD can also be referenced by an MFLD statement.

type : String

TYPE attribute.

Specifies the device type and model number of a device using this format description. The 3284-3 printer attached to a 3275 is supported only as TYPE=3270P. The model number specified when defining a format for a 3284-3 is the model number of the associated 3275.

TYPE=3270-An specifies a symbolic name for 3270 and SLU 2 displays with the screen size defined during IMS system definition, feature numbers n=1-15. This specification causes the MFS Language utility to read the MFS device characteristics table (DFSUDT0x) to extract the screen size.

width : int

WIDTH attribute.

Specifies the maximum line width for this DEV type as one of:

- Number of print positions per line of input or output data
- Number of punch positions per card of input or output data
- Card width for card reader input data

The default is 120 for 3270P output. Line width is specified relative to column 1, regardless of whether a left margin value is specified in the HTAB= keyword. The width specified must be greater than or equal to 1.

For 3270P devices, if WIDTH is specified, then FEAT=(1...10) must also be specified. If FEAT=(1...10) is specified, and WIDTH= is not specified, WIDTH= defaults to 120.

MFSIfCondition

This class encapsulates the MFS "IF" statement.

The IF statement defines an entry in the table named by the previous TABLE statement. Each IF statement defines a conditional operation and an associated control or branching function to be performed if the condition is true. All attributes are supported

condition : MFSConditionType

COND attribute.

condition has the following format:

IF (DATA | LENGTH) (=,<,>, ,×,×)

(literal | data-length) function

- DATA specifies that the conditional operation is to be performed against the data received from the device for the field.
- LENGTH specifies that the conditional operation is testing the number of characters entered for the field. The size limit for this field is the same as for DFLDs (see "DFLD Statement" in topic 2.5.1.5.8).
- =,<,>, ,×,× specify the conditional relationship that must be true to invoke the specified control function.
- 'literal' is a literal string to which input data is to be compared. The compare is done before the input is translated to upper case. If 'literal' is specified, DATA must be specified in the first operand. If the input data length is not equal to the literal string length, the compare is performed with the smaller length, unless the conditional relationship is and the data length is zero, in which case the control function is performed. If the input is in lowercase, the ALPHA statement should be used and the literal coded in lowercase.
- data-length specifies an integer value to which the number of characters of input data for the field is compared.
- NOFUNC specifies that conditional function testing is to be terminated.
- NEXTTP--PAGE ADVANCE specifies a request for the next physical page in the current output message. If no output message is in progress, no explicit response is made.

-
- NEXTMSG--MESSAGE ADVANCE specifies a request to dequeue the output message in progress (if any) and to send the next output message in the queue (if any).
 - NEXTMSGP--MESSAGE ADVANCE PROTECT specifies a request to dequeue the output message in progress (if any), and either send the next output message or return an information message indicating that no next message exists.
 - NEXTLP--NEXT LOGICAL PAGE specifies a request for the next logical page of the current message.
 - PAGEREQ--LOGICAL PAGE REQUEST specifies that the second through last characters of input data are to be considered as a logical page request.
 - ENDMPP--END MULTIPLE PAGE INPUT specifies the end of multiple physical page input (this input is the last for the message being created).

action : String

COND attribute.

Contains the 'function' described above.

MFSLogicalPage

This class encapsulates the MFS "LPAGE" statement.

The optional LPAGE statement defines a group of segments comprising a logical page. It is implied if not present. All attributes are supported.

condition : MFSConditionType

COND attribute.

Describes a conditional test that, if successful, specifies that the segment and field definitions following this LPAGE are to be used for output editing of this logical page. The specified portion of the first segment of a logical page is examined to determine if it is greater than (>), less than (<), greater than or equal to (×), less than or equal to (×), equal to (=), or not equal to (ne) the specified literal value to determine if this LPAGE is to be used for editing. COND= is not required for the last LPAGE statement in the MSG definition.

The area examined can be defined by a field name (mfldname), an offset in a field (mfldname(pp) where pp is the offset in the named field), or an offset in the segment (segoffset). If the mfldname(pp) form is used, pp must be greater than or equal to 1. The length of the compare is the length of the specified literal. If OPT=3 is specified on the previous MSG statement, the area to be examined must be within one field as defined on an MFLD statement.

If segoffset is used, it is relative to zero, and the specification of that offset must allow for LLZZ of the segment (that is, the first data byte is at offset 4).

If *pp* is used, the offset is relative to 1 with respect to the named field (that is, the first byte of data in the field is at offset 1, not zero).

If the *mfldname* specified is defined with *ATTR=YES*, the *pp* offset must be used. The minimum offset specified must be 3. That is, the first byte of data in the field is at offset 3, following the two bytes of attributes.

If *ATTR=nn* is specified, the minimum offset must be one plus twice *nn*. Thus, if *ATTR=2* is specified, *pp* must be at least 5, and, if *ATTR=(YES,2)* is specified, *pp* must be at least 7.

If the conditional tests for all *LPAGE*s fail, the last *LPAGE* in this *MSG* definition is used for editing.

If *LPAGE* selection is to be specified using the command data field, that is, */FORMAT modname...(data)*, the *MFLD* specified in the *LPAGE COND=mfldname* parameter should be within the first 8 bytes of the associated *LPAGE*s of the *MOD*.

prompt : 0..1 MFSDeviceField

PROMPT attribute.

Specifies the name of the *DFLD* into which *MFS* should insert the specified literal when formatting the last logical page of an output message. If *FILL=NULL* is specified once the prompt literal is displayed, it can remain on the screen if your response does not cause the screen to be reformatted.

MFSMessageDescriptor

This class encapsulates the *MFS "MSG"* statement.

The *MSG* statement initiates and names a message input or output definition. All attributes are supported.

fill : String

FILL attribute.

Specifies a fill character for output device fields. This operand is valid only if *TYPE=OUTPUT*. The default is *C' '*. The fill specification is ignored unless *FILL=NONE* is specified on the *DPAGE* statement in the *FMT* definition. For 3270 output when *EGCS* fields are present, only *FILL=PT* or *FILL=NULL* should be specified. A *FILL=PT* erases an output field (either a 1- or 2-byte field) only when data is sent to the field, and thus does not erase the *DFLD* if the application program message omits the *MFLD*.

- Character *'c'* is used to fill device fields. For 3270 display devices, any specification with a value less than *X'3F'* is changed to *X'00'* for control characters or to *X'40'* for other non-graphic characters. For all other devices, any *FILL=C'c'* specification with a value less than *X'3F'* is ignored and defaulted to *X'3F'* (which is equivalent to a specification of *FILL=NULL*).
- *NULL* specifies that fields are not to be filled.

-
- PT is identical to NULL except for 3270 display. For 3270 display, PT specifies that output fields that do not fill the device field (DFLD) are followed by a program tab character to erase data previously in the field.

ignoreSource : Boolean

SOR attribute.

Specifies the source name of the FMT statement, which, with the DEV statement, defines the terminal or remote program data fields processed by this message descriptor. Specifying IGNORE for TYPE=OUTPUT causes MFS to use data fields specified for the device whose FEAT= operand specifies IGNORE in the device format definition. For TYPE=INPUT, IGNORE should be specified only if the corresponding message output descriptor specified IGNORE. If you use SOR=IGNORE, you must specify IGNORE on both the message input descriptor and the message output descriptor.

option : int

OPT attribute.

Specifies the message formatting option used by MFS to edit messages. The default is 1.

paging : Boolean

PAGE attribute.

Specifies whether (YES) or not (NO) operator logical paging (forward and backward paging) is to be provided for messages edited using this control block. This operand is valid only if TYPE=OUTPUT. The default is NO, which means that only forward paging of physical pages is provided.

type : MFSDescriptorType

TYPE attribute.

Defines this definition as a message INPUT or OUTPUT control block. The default is INPUT.

MFSMessageField

This class encapsulates the MFS "MFLD" statement.

The MFLD statement defines a message field as it will be presented to an application program as part of a message output segment. At least one MFLD statement must be specified for each MSG definition. All attributes are supported.

attributes : Boolean

ATTR attribute.

Specifies whether (YES) or not (NO) the application program can modify the 3270 attributes and the extended attributes (nn).

If YES, 2 bytes must be reserved for the 3270 attribute data to be filled in by the application program on output and to be initialized to blanks on input. These 2 bytes must be included in the LTH=specification.

The value supplied for nn is the number of extended attributes that can be dynamically modified. The value of nn can be a number from 1 to 6. An invalid specification will default to 1. Two additional bytes per attribute must be reserved for the extended attribute data to be filled in by the application program on output and to be initialized to blanks on input. These attribute bytes must be included in the MFLD LTH= specification.

Example: Shown below are valid specifications for ATTR= and the number of bytes that must be reserved for each different specification:

Specifications	Number of Bytes
MFLD ,ATTR=(YES,nn)	2 + (2 P nn)
MFLD ,ATTR=(NO,nn)	2 P nn
MFLD ,ATTR=(nn)	2 P nn
MFLD ,ATTR=YES	2
MFLD ,ATTR=NO	0

ATTR=YES and nn are invalid if a literal value has been specified through the positional parameter in an output message.

The attributes in a field sent to another IMS ISC subsystem are treated as input data by MFS regardless of any ATTR= specifications in the format of the receiving subsystem. For example, a message field (MFLD) defined as ATTR=(YES,1),LTH=5 would contain the following:

00A0C2F1C8C5D3D3D6

If the MFLD in the receiving subsystem is defined as LTH=9 and without ATTR=, the application program receives:

00A0C2F1C8C5D3D3D6

If the MFLD in the receiving subsystem is defined as LTH=13 and ATTR=(YES,1), the application program receives:

4040404000A0C2F1C8C5D3D3D6

If the MFLD in the receiving subsystem is defined as LTH=5 and ATTR=(YES,1), the application program receives:

4040404000A0C2F1C8

The input SEG statement should be specified as GRAPHIC=NO to prevent translation of the attribute data to uppercase.

exit : MFSExitType

EXIT attribute.

Describes the field edit exit routine interface for this message field. The exit routine number is specified in `exitnum`, and `exitvect` is a value to be passed to the exit routine when it is invoked for this field. The value of `exitnum` can range from 0 to 127. The value of `exitvect` can range from 0 to 255. The address of the field as it exists after MFS editing, (but before NULL compression for option 1 and 2), is passed to the edit exit routine, along with the vector defined for the field. (If `NOFLDEXIT` is specified for a DPM device, the exit routine will not be invoked.) The exit routine can return a code with a value from 0 to 255. MFS maintains the highest such code returned for each segment for use by the segment edit routine. `EXIT=` is invalid if `'literal'` is specified on the same MFLD statement.

extendedAttributes : Boolean

ATTR attribute.

See attributes documentation above.

fill : String

FILL attribute.

Specifies a character to be used to pad this field when the length of the data received from the device is less than the length of this field. This character is also used to pad when no data is received for this field (except when `MSG` statement specifies option 3.) This operand is only valid if `TYPE=INPUT`. The default is `X'40'`.

- `X'hh'` - Character whose hexadecimal representation is `hh` is used to fill fields. `FILL=X'3F'` is the same as `FILL=NULL`.
- `C'c'` - Character `c` is used to fill fields.
- `NULL` causes compression of the message segment to the left by the amount of missing data in the field.

justify : MFSJustifyType

JUST attribute.

Specifies that the data field is to be left-justified (L) or right-justified (R) and right- or left- truncated as required, depending upon the amount of data expected or presented by the device format control block. The default is L.

length : MFSLengthType

LTH attribute.

Length can be omitted if a literal is specified in the positional operand (`TYPE=INPUT`), in which case, length specified for literal is used. If `LTH=` is specified for a literal field, the specified literal is either truncated or padded with

blanks to the specified length. If the MFLD statement appears between a DO and an ENDDO statement, a length value is printed on the generated MFLD statement, regardless of whether LTH= is specified in the MFLD source statement.

value : String

Corresponds to the 'literal' field in the following description.

The device field name is specified via the 'deviceFields' relationship.

Specifies the device field name (defined via the DEV or DFLD statement) from which input data is extracted or into which output data is placed. If this parameter is omitted when defining a message output control block, the data supplied by the application program is not displayed on the output device. If the repetitive generation function of MFS is used (DO and ENDDO statements), dflename should be restricted to 6 characters maximum length. When each repetition of the statement is generated, a 2-character sequence number (01 to 99) is appended to dflename. If the dflename specified here is greater than 6 bytes and repetitive generation is used, dflename is truncated at 6 characters and a 2-character sequence number is appended to form an 8-character name. No error message is provided if this occurs. This parameter can be specified in one of the following formats:

- dflename identifies the device field name from which input data is extracted or into which output data is placed.
- 'literal' can be specified if a literal value is to be inserted in an input message.

(dflename,'literal')

If TYPE=OUTPUT, this describes the literal data to be placed in the named DFLD. When this form is specified, space for the literal must not be allocated in the output message segment supplied by the

application program.

If TYPE=INPUT, this describes the literal data to be placed in the message field when no data for this field is received from the device. If this dflename is used in the PFK parameter of a DEV statement, this literal is always replaced by the PF key literal or control function. However, when this dflename is specified in the PFK parameter, but the PF key is not used, the literal specified in the MFLD statement is moved into the message field. When physical paging is used, the literal is inserted in the field but is not processed until after the last physical page of the logical page has been displayed.

In both cases, if the LTH= operand is specified, the length of the literal is truncated or padded as necessary to the length of the LTH= specification. If the length of the specified literal is less than the defined field length, the literal is padded with blanks if TYPE=OUTPUT and with the specified fill character (FILL=) if TYPE=INPUT. If no fill character is specified for input, the literal is padded with blanks (the default). The length of the literal value cannot exceed 256 bytes.

(dfldname,system-literal) specifies a name from a list of system literals. A system literal functions like a normal literal except that the literal value is created during formatting prior to transmission to the device. The LTH=, ATTR=, and JUST= operands cannot be specified. When this form is specified, space for the literal must not be allocated in the output message segment supplied by the application program.

(,SCA) defines this output field as the system control area, which is not displayed on the output device. There can be only one such field in a logical page (LPAGE) and it must be in the first message segment of that page. If no logical pages are defined, only one SCA field can be defined and it must be in the first segment of the output message. This specification is valid only if TYPE=OUTPUT was specified on the previous MSG statement.

MFSPassword

This class encapsulates the MFS "PASSWORD" statement.

The PASSWORD statement identifies one or more fields to be used as an IMS password. When used, the PASSWORD statement and its associated MFLDs must precede the first SEG statement in an input LPAGE or MSG definition. Up to 8 MFLD statements can be specified after the PASSWORD statement but the total password length must not exceed 8 characters. The fill character must be X'40'. For option 1 and 2 messages, the first 8 characters of data after editing are used for the IMS password. For option 3 messages, the data content of the first field after editing is used for the IMS password.

A password for 3270 input can also be defined in a DFLD statement. If both password methods are used, the password specified in the MSG definition is used. All attributes are supported.

MFSegment

This class encapsulates the MFS "SEG" statement.

The SEG statement delineates message segments and is required only if multisegment message processing is required by the application program. Output message segments cannot exceed your specified queue buffer length. Only one segment should be defined for TYPE=INPUT MSGs when the input message destination is defined as a single segment command or transaction. If more than one segment is defined, and the definition is used to input a single segment command or transaction, care must be used to ensure that your input produces only one segment after editing. It is implied if not present. All attributes are supported.

exit : MFSExitType

EXIT attribute.

Describes the segment edit exit routine interface for this message segment. exitnum is the exit routine number and exitvect is a value to be passed to the exit routine when it is invoked for this segment. exitnum can range from 0 to 127. exitvect can range from 0 to 255. The SEG exit is invoked when processing completes for the input segment.

graphic : Boolean

GRAPHIC attribute.

Specifies for MSG TYPE=INPUT whether (YES) or not (NO) IMS should perform upper case translation on this segment if the destination definition requests it (see the EDIT= parameter of the TRANSACT or NAME macro). The default is YES. If input segment data is in non-graphic format (packed decimal, EGCS, binary, and so forth), GRAPHIC=NO should be specified. When GRAPHIC=NO is specified, FILL=NULL is invalid for MFLDs within this segment.

The list below shows the translation that occurs when GRAPHIC=YES is specified and the input message destination is defined as requesting upper case translation:

Before Translation	After Translation
a through z	A through Z
X'81' through X'89	'X'C1' through X'C9'
X'91' through X'99	'X'D1' through X'D9'
X'A2' through X'A9	'X'E2' through X'E9'

If FILL=NULL is specified for any MFLD in a segment defined as GRAPHIC=YES, the hexadecimal character X'3F' is compressed out of the segment. If GRAPHIC=NO and FILL=NULL are specified in the SEG statement, any X'3F' in the non-graphic data stream is compressed out of the segment and undesirable results might be produced. Non-graphic data should be sent on output as fixed length output fields and the use of FILL=NULL is not recommended in this case.

For MSG TYPE=OUTPUT, the GRAPHIC= keyword applies only for DPM. It specifies whether (YES) or not (NO) non-graphic control characters (X'00' to X'3F') in the data from the IMS application program are to be replaced by blanks. The default value is YES. If NO is specified, MFS allows any bit string received from an IMS application program to flow unmodified through MFS to the remote program.

Restriction: When GRAPHIC=NO is specified, IMS application programs using Options 1 and 2 cannot omit segments in the middle of an LPAGE, or truncate or omit fields in the segment using the null character (X'3F').

MFSTable

This class encapsulates the MFS "TABLE" statement.

The TABLE statement initiates and names an operator control table that can be referred to by the OPCTL keyword of the DFLD statement. The TABLE statement, and the IF and TABLEEND statements that follow, must be outside of a MSG or FMT definition. All attributes are supported.

A.3 CICS BMS Metamodel

CICS applications are able to use a logical abstraction of a terminal datastream using CICS Basic Mapping Support (BMS) function. Its highest use is with the IBM3270 family of alphanumeric displays and associated printers but does support other devices and MQ queues. The programmer creates an input file containing the variable data from the application to be displayed on output or formatted on input plus the constant 'boilerplate' that should appear on the screen. Each field can have attributes added to it, for example, color, protection so that it cannot be overwritten by the operator and various productivity options such as cursor positioning and auto-skipping to the next input field. These field are aggregated together into a MAP. MAPs may also be aggregated into MAPSETs.

The input file is pre-processed to provide an application structure which will be included with the CICS application program giving the programmer fields in which to place the variable data, and secondly produces a file which contains all the constant data and the attributes of each field. A simple view of this is that the BMS input file has the same attributes as an HTTP data, formatting commands are mixed with the data, the output of the BMS processor is almost a parallel with XML and XSL, the data structure holding the data items and the file holding all the style information.

Unfortunately there are two pieces of state data held in the BMS 'style' sheet, namely the initial cursor position and an attribute declaration which will force the terminal to return the data on the screen whether or not the operator has changed it. When an EXEC CICS SEND MAP is performed, BMS will interpret the map file and merge in the data from the application structure and any overridden attributes, and build the device dependent data stream required for the terminal. Conversely on an EXEC CICS RECEIVE MAP the inbound datastream is mapped into the application structure with whatever filling or conversion that is required.

The CICS BMS metamodel captures the meta data associated with screen formatting for CICS applications. BMSField identifies the signature of a CICS BMS message, which can include inputs, outputs, and return types. BMSField associates with TDLElement, which provides the linkage to the language specific and physical representations of the data that a BMSField represents. The following figures illustrate the classes that constitute the CICS BMS metamodel and show how the classes relate to each other. Following the diagrams is a brief explanation of what each class represents.

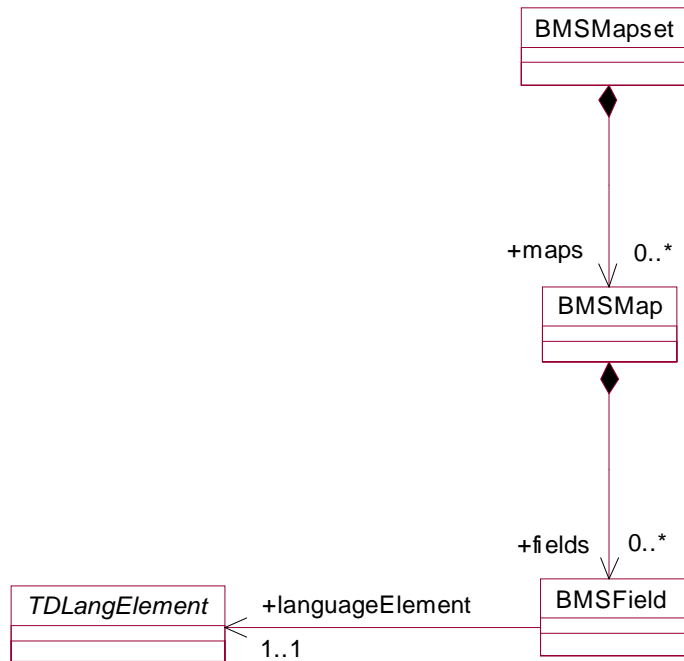

Figure A-10 CICS BMS Relationship View

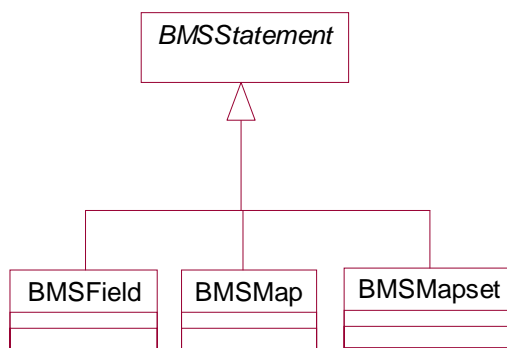

Figure A-11 CICS BMS Inheritance View

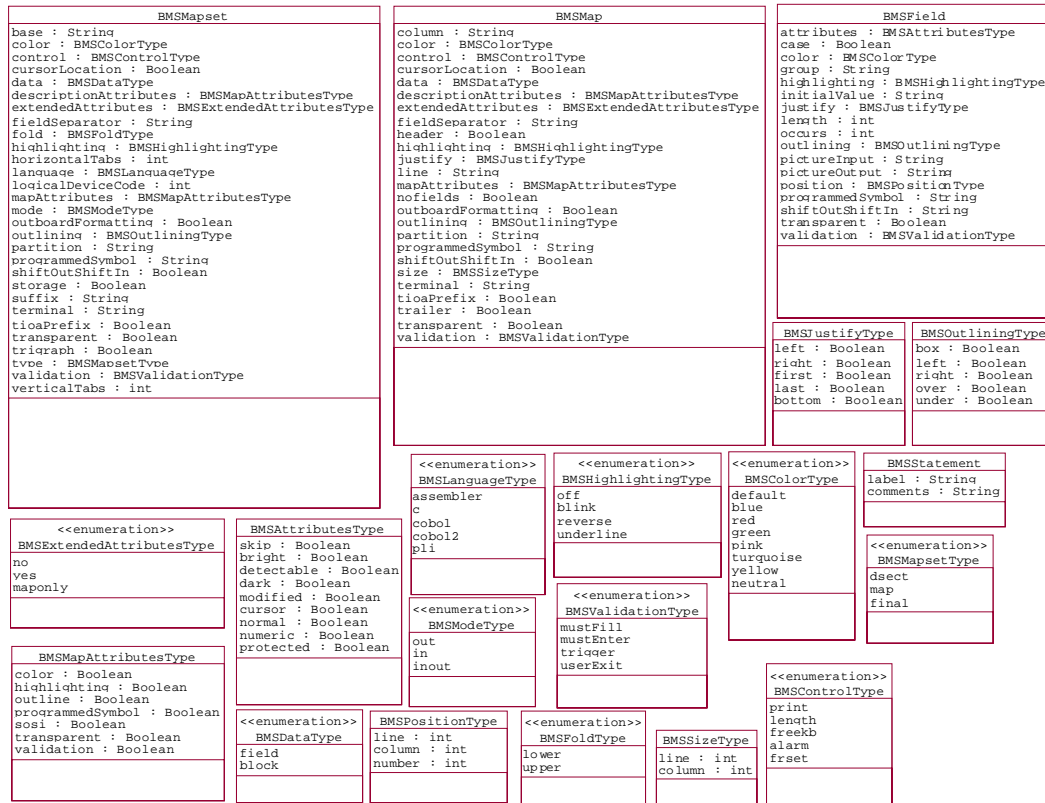

Figure A-12 CICS BMS Attributes

A.1.4 CICS BMS Metamodel Descriptions

BMSAttributesType

BMSAttributesType is the ATTRB statement. This operand applies only to 3270 data stream devices; it is ignored for other devices, except thatATTRB=DRK is honored for the SCS Printer Logical Unit. It is also ignored (except for ATTRB=DRK) if the NLEOM option is specified on the SEND MAP command for transmission to a 3270 printer. In particular, ATTRB=DRK should not be used as a method of protecting secure data on output on non-3270, non-SCS printer terminals.

If ATTRB is specified within a group of fields, it must be specified in the first field entry. A group of fields appears as one field to the 3270. Therefore, theATTRB specification refers to all of the fields in a group as one field rather than as individual fields. It specifies device-dependent characteristics and attributes, such as the

capability of a field to receive data, or the intensity to be used when the field is output. It could however, be used for making an input field non-display for secure entry of a password from a screen.

For input map fields, DET and NUM are the only valid options; all others are ignored.

ASKIP is the default and specifies that data cannot be keyed into the field and causes the cursor to skip over the field.

BRT specifies that a high-intensity display of the field is required. Because of the 3270 attribute character bit assignments, a field specified as BRT is also potentially light pen detectable. However, for the field to be recognized as detectable by BMS, DET must also be specified.

- DET specifies that the field is potentially detectable. The first character of a 3270 detectable field must be one of the following:

? > & blank

If ? or >, the field is a selection field; if & or blank, the field is an attention field. (See An Introduction to the IBM 3270 Information Display System for further details about detectable fields.)

A field for which BRT is specified is potentially detectable to the 3270, because of the 3270 attribute character bit assignments, but is not recognized as such by BMS unless DET is also specified.

DET and DRK are mutually exclusive. If DET is specified for a field on a map with MODE=IN, only one data byte is reserved for each input field. This byte is set to X'00', and remains unchanged if the field is not selected. If the field is selected, the byte is set to X'FF'.

No other data is supplied, even if the field is a selection field and the ENTER key has been pressed.

If the data in a detectable field is required, all of the following conditions must be fulfilled:

1. The field must begin with one of the following

characters:

? > & blank

and DET must be specified in the output map.

2. The ENTER key (or some other attention key) must be pressed after the field has been selected, although the ENTER key is not required for detectable fields beginning with & or a blank.
3. DET must not be specified for the field in the input

map. DET must, however, be specified in the output map.

For more information about BMS support of the light pen, see the CICS Application Programming Guide.

- DRK specifies that the field is non-print/non-display. DRK cannot be specified if DET is specified.

FSET specifies that the modified data tag (MDT) for this field should be set when the field is sent to a terminal. Specification of FSET causes the 3270 to treat the field as though it has been modified. On a subsequent read from the terminal, this field is read, whether or not it has been modified. The MDT remains set until the field is rewritten without ATTRB=FSET, or until an output mapping request causes the MDT to be reset.

Either of two sets of defaults may apply when a field to be displayed on a 3270 is being defined but not all parameters are specified. If no ATTRB parameters are specified, ASKIP and NORM are assumed. If any parameter is specified, UNPROT and NORM are assumed for that field unless overridden by a specified parameter.

- IC specifies that the cursor is to be placed in the first position of the field. The IC attribute for the last field for which it is specified in a map is the one that takes effect. If not specified for any fields in a map, the default location is zero. Specifying IC with ASKIP or PROT causes the cursor to be placed in an un-keyable field.

This option can be overridden by the CURSOR option of the SEND MAP command that causes the write operation.

- NORM specifies that the field intensity is to be normal.
- NUM ensures that the data entry keyboard is set to numeric shift for this field unless the operator presses the alpha shift key, and prevents entry of nonnumeric data if the Keyboard Numeric Lock feature is installed.
- PROT specifies that data cannot be keyed into the field. If data is to be copied from one device to another attached to the same 3270 control unit, the first position (address 0) in the buffer of the device to be copied from must not contain an attribute byte for a protected field. Therefore, when preparing maps for 3270s, ensure that the first map of any page does not contain a protected field starting at position 0.
- UNPROT specifies that data can be keyed into the field.

BMSColorType

BMSColorType indicates the individual color, or the default color for the mapset (where applicable). The valid colors are blue, red, pink, green, turquoise, yellow, and neutral. The COLOR operand is ignored unless the terminal supports color.

BMSControlType

BMSControlType is the CTRL statement. It defines characteristics of IBM 3270 terminals. Use of any of the control options in the SEND MAP command overrides all control options in the DFHMDI macro, which in turn overrides all control options in the DFHMSD macro.

If CTRL is used with cumulative BMS paging (that is, the ACCUM option is used on the BMS SEND MAP commands), it must be specified on the last (or only) map of a page, unless it is overridden by the ALARM, FREEKB and so on, options on the SEND MAP or accumulated SEND CONTROL command.

PRINT must be specified if the printer is to be started; if omitted, the data is sent to the printer buffer but is not printed. This operand is ignored if the mapset is used with 3270 displays without the Printer Adapter feature.

LENGTH indicates the line length on the printer; length can be specified as L40, L64, L80, or HONEOM. L40, L64, and L80 force a new line after 40, 64, or 80 characters, respectively. HONEOM causes the default printer line length to be used. If this option is omitted, BMS sets the line length from the terminal definition page size.

FREEKB causes the keyboard to be unlocked after the map is written. If FREEKB is not specified, the keyboard remains locked; data entry from the keyboard is inhibited until this status is changed.

ALARM activates the 3270 audible alarm if available.

FRSET specifies that the modified data tags (MDTs) of all fields currently in the 3270 buffer are to be reset to an unmodified condition (that is, field reset) before map data is written to the buffer. This allows the DFHMDF macro with the ATTRB operand to control the final status of any fields written or rewritten in response to a BMS command.

Note: CTRL cannot be specified in the DFHMDI and DFHMSD macros in the same mapset.

BMSDataType

BMSDataType can be either "field" or "block".

BMSExtendedAttributesType

BMSExtendedAttributesType can be "no", "yes", or "maponly".

BMSField

BMSField is implemented by the DFHMDF macro. BMSField has the following attributes:

-
- GRPNAME is the name used to generate symbolic storage definitions and to combine specific fields under one group name. The same group name must be specified for each field that is to belong to the group. The length of the name is up to 30 characters though you should refer to the compiler manual to make sure that there are no other restrictions on the length. If this operand is specified, the OCCURS operand cannot be specified.

The fields in a group must follow on; there can be gaps between them, but not other fields from outside the group. A field name must be specified for every field that belongs to the group, and the POS operand must also be specified to ensure that the fields follow each other. All the DFHMDF macros defining the fields of a group must be placed together, and in the correct order (ascending numeric order of the POS value).

For example, the first 20 columns of the first six lines of a map can be defined as a group of six fields, as long as the remaining columns on the first five lines are not defined as fields.

- attributes is the ATTRB operand specified on the first field of the group applies to all of the fields within the group.
- length is the LENGTH operand. It specifies the length (1-256 bytes) of the field or group of fields. This length should be the maximum length required for application program data to be entered into the field; it should not include the one-byte attribute indicator appended to the field by CICS for use in subsequent processing. The length of each individual subfield within a group must not exceed 256 bytes. LENGTH can be omitted if PICIN or PICOUT is specified, but is required otherwise. You can specify a length of zero only if you omit the label (field name) from the DFHMDF macro. That is, the field is not part of the application data structure and the application program cannot modify the attributes of the field. You can use a field with zero length to delimit an input field on a map.

The map dimensions specified in the SIZE operand of the DFHMDF macro defining a map can be smaller than the actual page size or screen size defined for the terminal.

If the LENGTH specification in a DFHMDF macro causes the map-defined boundary on the same line to be exceeded, the field on the output screen is continued by wrapping.

- occurs is the OCCURS operand. It specifies that the indicated number of entries for the field are to be generated in a map, and that the map definition is to be generated in such a way that the fields are addressable as entries in a matrix or an array. This permits several data fields to be addressed by the same name (subscripted) without generating a unique name for each field.

OCCURS and GRPNAME are mutually exclusive; that is, OCCURS cannot be used when fields have been defined under a group name. If this operand is omitted, a value of OCCURS=1 is assumed.

- pictureInput is the PICIN operand (COBOL and PL/I only). It specifies a picture to be applied to an input field in an IN or INOUT map; this picture serves as an editing specification that is passed to the application program, thus permitting the user to exploit the editing capabilities of COBOL or PL/I. BMS checks that the specified characters are valid picture specifications for the language of the map.

However, the validity of the input data is not checked by BMS or the high-level language when the map is used, so any desired checking must be performed by the application program. The length of the data associated with "value" should be the same as that specified in the LENGTH operand if LENGTH is specified. If both PICIN and PICOUT are used, an error message is produced if their calculated lengths do not agree; the shorter of the two lengths is used. If PICIN or PICOUT is not coded for the field definition, a character definition of the field is automatically generated regardless of other operands that are coded, such as ATTRB=NUM.

Note: The valid picture values for COBOL input maps are:

A P S V X 9 / and (

The valid picture values for PL/I input maps are:

A B E F G H I K M P R S T V X Y and Z

1 2 3 6 7 8 9 / + - , . * \$ and (

For PL/I, a currency symbol can be used as a picture character. The symbol can be any sequence of characters enclosed in < and >, for example <DM>.

Refer to the appropriate language reference manual for the correct syntax of the PICTURE attribute.

- pictureOutput is the PICOUT operand (COBOL and PL/I only). It is similar to PICIN, except that a picture to be applied to an output field in the OUT or INOUT map is generated.

The valid picture values for COBOL output maps are:

A B E P S V X Z 0 9 , . + - \$ CR DB / and (

The valid picture values for PL/I output maps are:

A B E F G H I K M P R S T V X Y and Z

1 2 3 6 7 8 9 / + - , . * \$ CR DB and (

For PL/I, a currency symbol can be used as a picture character. The symbol can be any sequence of characters enclosed in < and >, for example <DM>.

Refer to the appropriate language reference manual for the correct syntax of the PICTURE attribute.

Note: COBOL supports multiple currency signs and multi-character currency signs in PICTURE specifications.

The default currency picture symbol is the dollar sign (\$), which represents the national currency symbol; for example the dollar (\$), the pound (£), or the yen (•).

The default currency picture symbol may be replaced by a different currency picture symbol that is defined in the SPECIAL NAMES clause. The currency sign represented by the picture symbol is defined in the same clause. For example:

SPECIAL NAMES.

CURRENCY SIGN IS '\$' WITH PICTURE SYMBOL '\$'.

CURRENCY SIGN IS '£' WITH PICTURE SYMBOL '£'.

CURRENCY SIGN IS 'EUR' WITH PICTURE SYMBOL '#'.

WORKING STORAGE SECTION.

01 USPRICE PIC \$99.99.

01 UKPRICE PIC £99.99.

01 ECPRICE PIC #99.99.

LENGTH must be specified when PICOUT specifies a COBOL picture containing a currency symbol that will be replaced by a currency sign of length greater than 1.

- position is the POS operand. It specifies the location of a field. This operand specifies the individually addressable character location in a map at which the attribute byte that precedes the field is positioned.

Position is a BMSPositionType which has the following attributes:

- number specifies the displacement (relative to zero) from the beginning of the map being defined.
- (line, column) specify lines and columns (relative to one) within the map being defined.

The location of data on the output medium is also dependent on DFHMDI operands. The first position of a field is reserved for an attribute byte. When supplying data for input mapping from non-3270 devices, the input data must allow space for this attribute byte. Input data must not start in column 1 but may start in column 2.

The POS operand always contains the location of the first position in a field, which is normally the attribute byte when communicating with the 3270. For the second and subsequent fields of a group, the POS operand points to an assumed attribute-byte position, ahead of the start of the data, even though no actual attribute byte is necessary. If the fields follow on immediately from one another, the POS operand should point to the last character position in the previous field in the group.

When a position number is specified that represents the last character position in the 3270, two special rules apply:

- ATTRIB=IC should not be coded. The cursor can be set to location zero by using the CURSOR option of a SEND MAP, SEND CONTROL, or SEND TEXT command.
- If the field is to be used in an output mapping operation with MAP=DATAONLY on the SEND MAP command, an attribute byte for that field must be supplied in the symbolic map data structure by the application program.

-
- ProgrammedSymbol is the PS operand. It specifies that programmed symbols are to be used. This overrides any PS operand set by the DFHMDI macro or the DFHMMSD macro.

BASE is the default and specifies that the base symbol set is to be used.

psid specifies a single EBCDIC character, or a hexadecimal code of the form X'nn', that identifies the set of programmed symbols to be used.

The PS operand is ignored unless the terminal supports programmed symbols.

SOSI indicates that the field may contain a mixture of EBCDIC and DBCS data. The DBCS subfields within an EBCDIC field are delimited by SO (shift out) and SI (shift in) characters. SO and SI both occupy a single screen position (normally displayed as a blank). They can be included in any non-DBCS field on output, if they are correctly paired. The terminal user can transmit them inbound if they are already present in the field, but can add them to an EBCDIC field only if the field has the SOSI attribute.

TRANSP determines whether the background of an alphanumeric field is transparent or opaque, that is, whether an underlying (graphic) presentation space is visible between the characters.

BMSFoldType

BMSFoldType specifies whether to generate lowercase or uppercase characters only in C language programs in the appropriate data structure.

BMSHighlightingType

BMSHighlightingType specifies the default highlighting attribute for all fields in all maps in a mapset. This is overridden by the HIGHLIGHT operand of the DFHMDI, which is in turn overridden by the HIGHLIGHT operand of the DFHMDF. The HIGHLIGHT operand is ignored unless the terminal supports it.

BMSHighlightingType has the following attributes:

- OFF is the default and indicates that no highlighting is used.
- BLINK specifies that the field must blink.
- REVERSE specifies that the character or field is displayed in reverse video, for example, on a 3278, black characters on a green background.
- UNDERLINE specifies that a field is underlined.

BMSJustifyType

BMSJustifyType can be "left", "right", "first", "last", or "bottom".

BMSLanguageType

BMSLanguageType specifies language types:

- Assembler
- C
- COBOL
- COBOL2
- PL/I

BMSMap

BMSMap is implemented by DFHMDI macro. BMSMap has the following attributes:

- MAPNAME is the name of the map and consists of 1-7 characters.
- COLUMN specifies the column in a line at which the map is to be placed, that is, it establishes the left or right map margin.
- JUSTIFY controls whether map and page margin selection and column counting are to be from the left or right side of the page. The columns between the specified map margin and the page margin are not available for subsequent use on the page for any lines included in the map.
- NUMBER is the column from the left or right page margin where the left or right map margin is to be established.
- NEXT indicates that the left or right map margin is to be placed in the next available column from the left or right on the current line.
- SAME indicates that the left or right map margin is to be established in the same column as the last non-header or
- nontrailer map used that specified COLUMN=number and the same JUSTIFY operands as this macro. For input operations, the map is positioned at the extreme left-hand or right-hand side, depending on whether JUSTIFY=LEFT or JUSTIFY=RIGHT has been specified.
- Line is the LINE operand. It specifies the starting line on a page in which data for a map is to be formatted.
 - NUMBER is a value in the range 1-240, specifying a starting line number. A request to map, on a line and column, data that has been formatted in response to a preceding BMS command, causes the current page to be treated as though complete. The new data is formatted at the requested line and column on a new page.
 - NEXT specifies that formatting of data is to begin on the next available completely empty line. If LINE=NEXT is specified in the DFHMDI macro, it is ignored for input operations and LINE=1 is assumed.

-
- SAME specifies that formatting of data is to begin on the same line as that used for a preceding BMS command. If COLUMN=NEXT is specified, it is ignored for input operations and COLUMN=1 is assumed. If the data does not fit on the same line, it is placed on the next available line that is completely empty.
 - SIZE(arg1,arg2) specifies the size of a map. arg2 = line is a value in the range 1-240, specifying the depth of a map as a number of lines. arg1 = column is a value in the range 1-240, specifying the width of a map as a number of columns. This operand is required in the following cases:
 - An associated DFHMDF macro with the POS operand is used.
 - The map is to be referred to in a SEND MAP command with the ACCUM option.
 - The map is to be used when referring to input data from other than a 3270 terminal in a RECEIVE MAP command.
 - ShiftOutShiftIn is the SOSI operand. It indicates that the field may contain a mixture of EBCDIC and DBCS data. The DBCS subfields within an EBCDIC field are delimited by SO (shift out) and SI (shift in) characters. SO and SI both occupy a single screen position (normally displayed as a blank). They can be included in any non-DBCS field on output, if they are correctly paired. The terminal user can transmit them inbound if they are already present in the field, but can add them to an EBCDIC field only if the field has the SOSI attribute.
 - TioaPrefix is a Boolean type for the TIOAPFX operand. It specifies whether BMS should include a filler in the symbolic description maps to allow for the unused TIOA prefix. This operand overrides the TIOAPFX operand specified for the DFHMSD macro.
 - YES specifies that the filler should be included in the symbolic description maps and should always be used for command-level application programs. If TIOAPFX=YES is specified, all maps within the mapset have the filler. TIOAPFX=YES
 - NO is the default and specifies that the filler is not to be included.

BMSMapAttributesType

BMSMapAttributesType has the following attributes:

- color : Boolean
- highlighting : Boolean
- outline : Boolean
- programmedSymbol : Boolean
- sosi : Boolean
- transparent : Boolean
- validation : Boolean

BMSMapset

BMSMapset is implemented by the DFHMSD macro. BMSMapset has the following attributes:

- type=DSECT ¶ MAP ¶ FINAL. Mandatory, this generates the two bits of a BMS entity.
- mode=OUT ¶ IN ¶ INOUT. OUT is default. INOUT says do both IN and OUT processing. With IN, I is appended to mapname, with OUT, O is appended to mapname.
- lang=ASM¶ COBOL ¶ COBOL2 ¶ PL/I ¶ C. ASM is default.
- fold=LOWER ¶ UPPER. LOWER is default. Only applies to C.
- dsect=ADS ¶ ADSL. ADS is default. ADSL requires lang = C.
- trigraph = YES only applies to lang = C.
- BASE specifies that the same storage base is used for the symbolic description maps from more than one mapset. The same name is specified for each mapset that is to share the same storage base. Because all mapsets with the same base describe the same storage, data related to a previously used mapset may be overwritten when a new mapset is used. Different maps within the same mapset also overlay one another.

This operand is not valid for assembler-language programs, and cannot be used when STORAGE=AUTO has been specified.

- term = type. Each terminal type is represented by a character. 3270 is default and is a blank. Added to MAPSET name, or, suffix = numchar which is also added to mapset name.
- CURSLOC indicates that for all RECEIVE MAP operations using this map on 3270 terminals, BMS sets a flag in the application data structure element for the field where the cursor is located.
- STORAGE depends upon the language in which application programs are written, as follows:

For a COBOL program, STORAGE=AUTO specifies that the symbolic description maps in the mapset are to occupy separate (that is, not redefined) areas of storage. This operand is used when the symbolic description maps are copied into the working-storage section and the storage for the separate maps in the mapset is to be used concurrently.

For a C program, STORAGE=AUTO specifies that the symbolic description maps are to be defined as having the automatic storage class. If STORAGE=AUTO is not specified, they are declared as pointers. You cannot specify both BASE=name and STORAGE=AUTO for the same mapset. If STORAGE=AUTO is specified and TIOAPFX is not, TIOAPFX=YES is assumed.

For a PL/I program, STORAGE=AUTO specifies that the symbolic description maps are to be declared as having the AUTOMATIC storage class. If STORAGE=AUTO is not specified, they are declared as BASED. You cannot specify both BASE=name and STORAGE=AUTO for the same mapset. If STORAGE=AUTO is specified and TIOAPFX is not, TIOAPFX=YES is assumed.

For an assembler-language program, STORAGE=AUTO specifies that individual maps within a mapset are to occupy separate areas of storage instead of overlaying one another.

This is derived from BMSStatement.

BMSMapsetType

BMSMapsetType specifies the type of map to be generated using the definition. Both types of map must be generated before the mapset can be used by an application program. If aligned symbolic description maps are required, you should ensure that you specify SYSPARM=ADSECT and SYSPARM=AMAP when you assemble the symbolic and physical maps respectively.

BMSMapsetType has the following attributes:

- DSECT specifies that a symbolic description map is to be generated. Symbolic description maps must be copied into the source program before it is translated and compiled.
- MAP specifies that a physical map is to be generated. Physical maps must be assembled or compiled, link-edited, and cataloged in the CICS program library before an application program can use them.
- FINAL denotes the end of a mapset.

BMSModeType

BMSModeType specifies whether the mapset is to be used for input, output, or both (i.e., input and output).

BMSOutliningType

BMSOutliningType is the OUTLINE statement. It allows lines to be included above, below, to the left, or to the right of a field. You can use these lines in any combination to construct boxes around fields or groups of fields.

BMSPositionType

BMSPositionType specifies where on the presentation space the field is to be placed.

BMSSizeType

BMSSizeType has the following attributes:

-
- line is an integer.
 - column is an integer.

BMSValidationType

BMSValidationType is the VALIDN statement. It specifies that validation is to be used if the terminal supports it or this field can be processed by the BMS global user exits

This overrides any VALIDN operand on the DFHMDI macro or the DFHMSD macro.

BMSValidationType has the following attributes:

- MUSTFILL specifies that the field must be filled completely with data. An attempt to move the cursor from the field before it has been filled, or to transmit data from an incomplete field, raises the INHIBIT INPUT condition
- MUSTENTER specifies that data must be entered into the field, though need not fill it. An attempt to move the cursor from an empty field raises the INHIBIT INPUT condition
- TRIGGER specifies that this field is a trigger field. Trigger fields are discussed in the CICS Application Programming Guide.
- USEREXIT specifies that this field is to be processed by the BMS global user exits, XBMIN and XBMOU, if this field is received or transmitted in a 3270 datastream when the respective exit is enabled. The USEREXIT specification applies to all 3270 devices.

The MUSTFILL, MUSTENTER, and TRIGGER specifications are valid only for terminals that support the field validation extended attribute, otherwise they are ignored.

