

Date: 3 December 2015



Decision Model and Notation

Version 1.1 RTF

OMG Document Number: dtc/15-11-51

Standard document URL: <http://www.omg.org/spec/DMN/1.1>

Machine Consumable File(s):

<http://www.omg.org/spec/DMN/20151101/dmn.xmi>

<http://www.omg.org/spec/DMN/20151101/dmn.xsd>

<http://www.omg.org/spec/DMN/20151101/ch11example.xml>

Copyrights

Copyright © 2013, Decision Management Solutions

Copyright © 2013, Escape Velocity LLC

Copyright © 2013, Fair Isaac Corporation

Copyright © 2013, International Business Machines Corporation

Copyright © 2013, Knowledge Partners International

Copyright © 2013, KU Leuven

Copyright © 2013, Model Systems Limited

Copyright © 2013, Oracle Incorporated

Copyright © 2013, TIBCO Software Inc.

Copyright © 2014, Object Management Group, Inc.

USE OF SPECIFICATION - TERMS, CONDITIONS & NOTICES

The material in this document details an Object Management Group specification in accordance with the terms, conditions and notices set forth below. This document does not represent a commitment to implement any portion of this specification in any company's products. The information contained in this document is subject to change without notice.

LICENSES

The companies listed above have granted to the Object Management Group, Inc. (OMG) a nonexclusive, royalty-free, paid up, worldwide license to copy and distribute this document and to modify this document and distribute copies of the modified version. Each of the copyright holders listed above has agreed that no person shall be deemed to have infringed the copyright in the included material of any such copyright holder by reason of having used the specification set forth herein or having conformed any computer software to the specification.

Subject to all of the terms and conditions below, the owners of the copyright in this specification hereby grant you a fully-paid up, non-exclusive, nontransferable, perpetual, worldwide license (without the right to sublicense), to use this specification to create and distribute software and special purpose specifications that are based upon this specification, and to use, copy, and distribute this specification as provided under the Copyright Act; provided that: (1) both the copyright notice identified above and this permission notice appear on any copies of this specification; (2) the use of the specifications is for informational purposes and will not be copied or posted on any network computer or broadcast in any media and will not be otherwise resold or transferred for commercial purposes; and (3) no modifications are made to this specification. This limited permission automatically terminates without notice if you breach any of these terms or conditions. Upon termination, you will destroy immediately any copies of the specifications in your possession or control.

PATENTS

The attention of adopters is directed to the possibility that compliance with or adoption of OMG specifications may require use of an invention covered by patent rights. OMG shall not be responsible for identifying patents for which a license may be required by any OMG specification, or for conducting legal inquiries into the legal validity or scope of those patents that are brought to its attention. OMG specifications are prospective and advisory only. Prospective users are responsible for protecting themselves against liability for infringement of patents.

GENERAL USE RESTRICTIONS

Any unauthorized use of this specification may violate copyright laws, trademark laws, and communications regulations and statutes. This document contains information which is protected by copyright. All Rights Reserved. No part of this work covered by copyright herein may be reproduced or used in any form or by any means--graphic, electronic, or mechanical, including photocopying, recording, taping, or information storage and retrieval systems--without permission of the copyright owner.

DISCLAIMER OF WARRANTY

WHILE THIS PUBLICATION IS BELIEVED TO BE ACCURATE, IT IS PROVIDED "AS IS" AND MAY CONTAIN ERRORS OR MISPRINTS. THE OBJECT MANAGEMENT GROUP AND THE COMPANIES LISTED ABOVE MAKE NO WARRANTY OF ANY KIND, EXPRESS OR IMPLIED, WITH REGARD TO THIS PUBLICATION, INCLUDING BUT NOT LIMITED TO ANY WARRANTY OF TITLE OR OWNERSHIP, IMPLIED WARRANTY OF MERCHANTABILITY OR WARRANTY OF FITNESS FOR A PARTICULAR PURPOSE OR USE. IN NO EVENT SHALL THE OBJECT MANAGEMENT GROUP OR ANY OF THE COMPANIES LISTED ABOVE BE LIABLE FOR ERRORS CONTAINED HEREIN OR FOR DIRECT, INDIRECT, INCIDENTAL, SPECIAL, CONSEQUENTIAL, RELIANCE OR COVER DAMAGES, INCLUDING LOSS OF PROFITS, REVENUE, DATA OR USE, INCURRED BY ANY USER OR ANY THIRD PARTY IN CONNECTION WITH THE FURNISHING, PERFORMANCE, OR USE OF THIS MATERIAL, EVEN IF ADVISED OF THE POSSIBILITY OF SUCH DAMAGES.

The entire risk as to the quality and performance of software developed using this specification is borne by you. This disclaimer of warranty constitutes an essential part of the license granted to you to use this specification.

RESTRICTED RIGHTS LEGEND

Use, duplication or disclosure by the U.S. Government is subject to the restrictions set forth in subparagraph (c) (1) (ii) of The Rights in Technical Data and Computer Software Clause at DFARS 252.227-7013 or in subparagraph (c)(1) and (2) of the Commercial Computer Software - Restricted Rights clauses at 48 C.F.R. 52.227-19 or as specified in 48 C.F.R. 227-7202-2 of the DoD F.A.R. Supplement and its successors, or as specified in 48 C.F.R. 12.212 of the Federal Acquisition Regulations and its successors, as applicable. The specification copyright owners are as indicated above and may be contacted through the Object Management Group, 109 Highland Avenue, Needham, MA 02494, U.S.A.

TRADEMARKS

MDA®, Model Driven Architecture®, UML®, UML Cube logo®, OMG Logo®, CORBA® and XMI® are registered trademarks of the Object Management Group, Inc., and Object Management Group™, OMG™, Unified Modeling Language™, Model Driven Architecture Logo™, Model Driven Architecture Diagram™, CORBA logos™, XMI Logo™, CWM™, CWM Logo™, IIOP™, IMM™, OMG Interface Definition Language (IDL)™, and OMG SysML™ are trademarks of the Object Management Group. All other products or company names mentioned are used for identification purposes only, and may be trademarks of their respective owners.

COMPLIANCE

The copyright holders listed above acknowledge that the Object Management Group (acting itself or through its designees) is and shall at all times be the sole entity that may authorize developers, suppliers and sellers of computer software to use certification marks, trademarks or other special designations to indicate compliance with these materials.

Software developed under the terms of this license may claim compliance or conformance with this specification if and only if the software compliance is of a nature fully matching the applicable compliance points as stated in the specification. Software developed only partially matching the applicable compliance points may claim only that the software was based on this specification, but may not claim compliance or conformance with this specification. In the event that testing suites

are implemented or approved by Object Management Group, Inc., software developed using this specification may claim compliance or conformance with the specification only if the software satisfactorily completes the testing suites.

OMG's Issue Reporting Procedure

All OMG specifications are subject to continuous review and improvement. As part of this process we encourage readers to report any ambiguities, inconsistencies, or inaccuracies they may find by completing the Issue Reporting Form listed on the main web page <http://www.omg.org>, under Documents, Report a Bug/Issue (http://www.omg.org/report_issue.htm.)

Contents

Contents	6
Preface	11
OMG	11
OMG Specifications	11
Typographical Conventions	12
1 Scope	13
2 Conformance	14
2.1 Conformance levels	14
2.2 General conformance requirements	14
2.2.1 Visual appearance.....	14
2.2.2 Decision semantics.....	15
2.2.3 Attributes and model associations	15
3 References	16
3.1 Normative	16
3.2 Non-normative	17
4 Additional Information	19
4.1 Acknowledgements	19
4.2 IPR and Patents	19
4.3 Guide to the Specification	19
5 Introduction to DMN	21
5.1 Context	21
5.2 Scope and uses of DMN	23
5.2.1 Modeling human decision-making.....	24
5.2.2 Modeling requirements for automated decision-making	24
5.2.3 Implementing automated decision-making.....	25
5.2.4 Combining applications of modeling	25
5.3 Basic concepts	26
5.3.1 Decision requirements level.....	26
5.3.2 Decision logic level	27
5.3.3 Decision services.....	29
6 Requirements (DRG and DRD)	32

6.1	Introduction.....	32
6.2	Notation.....	32
6.2.1	DRD Elements.....	33
6.2.2	DRD Requirements.....	35
6.2.3	Connection rules.....	37
6.2.4	Partial views and hidden information.....	38
6.2.5	Decision service.....	38
6.3	Metamodel.....	39
6.3.1	DMN Element metamodel	39
6.3.2	Definitions metamodel	41
6.3.3	Import metamodel.....	43
6.3.4	Element Collection metamodel	44
6.3.5	DRG Element metamodel.....	44
6.3.6	Artifact metamodel	45
6.3.7	Decision metamodel	46
6.3.8	Business Context Element metamodel.....	49
6.3.9	Business Knowledge Model metamodel.....	51
6.3.10	Input Data metamodel.....	53
6.3.11	Knowledge Source metamodel.....	54
6.3.12	Information Requirement metamodel.....	55
6.3.13	Knowledge Requirement metamodel.....	56
6.3.14	Authority Requirement metamodel.....	56
6.3.15	Decision service metamodel	57
6.3.16	Extensibility	58
6.4	Examples.....	59
7	Relating Decision Logic to Decision Requirements.....	60
7.1	Introduction.....	60
7.2	Notation.....	62
7.2.1	Boxed Expressions	62
7.2.2	Boxed literal expression.....	63
7.2.3	Boxed invocation.....	64
7.3	Metamodel.....	64
7.3.1	Expression metamodel	65
7.3.2	ItemDefinition metamodel.....	66

7.3.3	InformationItem metamodel.....	67
7.3.4	Literal expression metamodel.....	68
7.3.5	Invocation metamodel.....	69
7.3.6	Binding metamodel.....	70
8	Decision Table.....	72
8.1	Introduction.....	72
8.2	Notation.....	75
8.2.1	Line style and color.....	75
8.2.2	Table orientation.....	75
8.2.3	Input expressions.....	78
8.2.4	Input values.....	78
8.2.5	Information Item names, output labels, and output component names.....	78
8.2.6	Output values.....	78
8.2.7	Multiple outputs.....	78
8.2.8	Input entries.....	79
8.2.9	Merged input entry cells.....	80
8.2.10	Output entry.....	80
8.2.11	Hit policy.....	81
8.2.12	Default output values.....	83
8.3	Metamodel.....	84
8.3.1	Decision Table metamodel.....	84
8.3.2	Decision Table Input and Output metamodel.....	86
8.3.3	Decision Rule metamodel.....	87
8.4	Examples.....	88
9	Simple Expression Language (S-FEEL).....	92
9.1	S-FEEL syntax.....	92
9.2	S-FEEL data types.....	93
9.3	S-FEEL semantics.....	94
9.4	Use of S-FEEL expressions.....	95
9.4.1	Item definitions.....	95
9.4.2	Invocations.....	95
9.4.3	Decision tables.....	95
10	Expression Language (FEEL).....	96

10.1	Introduction	96
10.2	Notation	96
10.2.1	Boxed Expressions	96
10.2.2	FEEL	103
10.3	Full FEEL Syntax and Semantics	104
10.3.1	Syntax	105
10.3.2	Semantics	109
10.3.3	XML Data	126
10.3.4	Built-in functions	129
10.4	Execution Semantics of Decision Services	137
10.5	Metamodel	138
10.5.1	Context metamodel	138
10.5.3	FunctionDefinition metamodel	139
10.5.4	List metamodel	140
10.5.5	Relation metamodel	140
10.6	Examples	140
10.6.1	Context	140
10.6.2	Calculation	141
10.6.3	If, In	142
10.6.4	Sum entries of a list	142
10.6.5	Invocation of user-defined PMT function	142
10.6.6	Sum weights of recent credit history	142
10.6.7	Determine if credit history contain a bankruptcy event	143
11	DMN Example	144
11.1	The business process model	144
11.2	The decision requirements level	145
11.3	The decision logic level	151
11.4	Executing the Decision Model	159
12	Exchange formats	162
12.1	Interchanging Incomplete Models	162
12.2	Machine Readable Files	162
12.3	XSD	162
12.3.1	Document Structure	162

12.3.2	References within the DMN XSD	162
Annex A.	Relation to BPMN.....	165
1.	Goals of BPMN and DMN.....	165
2.	BPMN Tasks and DMN Decisions.....	165
3.	Types of BPMN Tasks relevant to DMN.....	166
4.	Process gateways and Decisions	167
5.	Linking BPMN and DMN Models	167
Annex B.	Glossary	169

Preface

OMG

Founded in 1989, the Object Management Group, Inc. (OMG) is an open membership, not-for-profit computer industry standards consortium that produces and maintains computer industry specifications for interoperable, portable, and reusable enterprise applications in distributed, heterogeneous environments. Membership includes Information Technology vendors, end users, government agencies, and academia.

OMG member companies write, adopt, and maintain its specifications following a mature, open process. OMG's specifications implement the Model Driven Architecture® (MDA®), maximizing ROI through a full-lifecycle approach to enterprise integration that covers multiple operating systems, programming languages, middleware and networking infrastructures, and software development environments. OMG's specifications include: UML® (Unified Modeling Language™); CORBA® (Common Object Request Broker Architecture); CWM™ (Common Warehouse Metamodel); and industry-specific standards for dozens of vertical markets.

More information on the OMG is available at <http://www.omg.org/>.

OMG Specifications

As noted, OMG specifications address middleware, modeling and vertical domain frameworks. All OMG Specifications are available from the OMG website at:

<http://www.omg.org/spec>.

Specifications are organized by the following categories:

Business Modeling Specifications

Middleware Specifications

- **CORBA/IIOP**
- **Data Distribution Services**
- **Specialized CORBA**

IDL/Language Mapping Specifications

Modeling and Metadata Specifications

- **UML, MOF, CWM, XMI**
- **UML Profile**

Modernization Specifications

Platform Independent Model (PIM), Platform Specific Model (PSM), Interface Specifications

- **CORBAServices**
- **CORBAFacilities**

OMG Domain Specifications

CORBA Embedded Intelligence Specifications

CORBA Security Specifications

All of OMG's formal specifications may be downloaded without charge from our website. (Products implementing OMG specifications are available from individual suppliers.) Copies of specifications, available in PostScript and PDF format, may be obtained from the Specifications Catalog cited above or by contacting the Object Management Group, Inc. at:

OMG Headquarters
109 Highland Avenue
Needham, MA 02494
USA
Tel: +1-781-444-0404
Fax: +1-781-444-0320
Email: pubs@omg.org

Certain OMG specifications are also available as ISO standards. Please consult <http://www.iso.org>.

Typographical Conventions

The type styles shown below are used in this document to distinguish programming statements from ordinary English. However, these conventions are not used in tables or section headings where no distinction is necessary.

Times/Times New Roman - 10 pt.: Standard body text

Helvetica/Arial - 10 pt. Bold: OMG Interface Definition Language (OMG IDL) and syntax elements.

Courier/Courier New - 10 pt. Bold: Programming language elements.

Courier - 12 pt.: Name of modeling element (class or association)

Arial - 12pt.: syntax element.

Arial - 10 pt.: Examples and non-normative remarks

Helvetica/Arial - 10 pt: Exceptions

1 Scope

The primary goal of **DMN** is to provide a common notation that is readily understandable by all business users, from the business analysts needing to create initial decision requirements and then more detailed decision models, to the technical developers responsible for automating the decisions in processes, and finally, to the business people who will manage and monitor those decisions. **DMN** creates a standardized bridge for the gap between the business decision design and decision implementation. **DMN** notation is designed to be useable alongside the standard **BPMN** business process notation.

Another goal is to ensure that decision models are interchangeable across organizations via an XML representation.

The authors have brought forth expertise and experience from the existing decision modeling community and has sought to consolidate the common ideas from these divergent notations into a single standard notation.

2 Conformance

2.1 Conformance levels

Software may claim compliance or conformance with **DMN 1.1** if and only if the software fully matches the applicable compliance points as stated in the specification. Software developed only partially matching the applicable compliance points may claim that the software was based on this specification, but may not claim compliance or conformance with this specification.

The specification defines three levels of conformance, namely **Conformance Level 1**, **Conformance Level 2** and **Conformance Level 3**.

An implementation claiming conformance to Conformance Level 1 is not required to support Conformance Level 2 or Conformance Level 3. An implementation claiming conformance to Conformance Level 2 is not required to support Conformance Level 3.

An implementation claiming conformance to **Conformance Level 1** SHALL comply with all of the specifications set forth in clauses 6 (Decision Requirements), 7 (Decision Logic) and 8 (Decision Table) of this document. An implementation claiming conformance to Conformance Level 1 is never required to interpret expressions (modeled as an `Expression` elements) in decision models. However, to the extent that an implementation claiming conformance to Conformance Level 1 provides an interpretation to an expression, that interpretation SHALL be consistent with the semantics of expressions as specified in clause 7.

An implementation claiming conformance to **Conformance Level 2** SHALL comply with all of the specifications set forth in clauses 6 (Decision Requirements), 7 (Decision Logic) and 8 (Decision Table) of this document. In addition it is required to interpret expressions in the simple expression language (S-FEEL) specified in clause 9.

An implementation claiming conformance to **Conformance Level 3** SHALL comply with all of the specifications set forth in clauses 6 (Decision Requirements), 7 (Decision Logic), 8 (Decision Table) and 10 (Expression language) of this document. Notice that the simple expression language that is specified in clause 9 is a subset of FEEL, and that, therefore, an implementation claiming conformance to Conformance Level 3 can also claim conformance to Conformance Level 2 (and to Conformance Level 1).

In addition, an implementation claiming conformance to any of the three **DMN 1.1** conformance levels SHALL comply with all of the requirements set forth in Clause 2.2.

2.2 General conformance requirements

2.2.1 Visual appearance

A key element of **DMN** is the choice of shapes and icons used for the graphical elements identified in this specification. The intent is to create a standard visual language that all decision modelers will recognize and understand. An implementation that creates and displays decision model diagrams SHALL use the graphical elements, shapes, and markers illustrated in this specification.

There is flexibility in the size, color, line style, and text positions of the defined graphical elements, except where otherwise specified.

The following extensions to a **DMN** Diagram are permitted:

- New markers or indicators MAY be added to the specified graphical elements. These markers or indicators could be used to highlight a specific attribute of a **DMN** element or to represent a new subtype of the corresponding concept.
- A new shape representing a new kind of artifact MAY be added to a Diagram, but the new shape SHALL NOT conflict with the shape specified for any other **DMN** element or marker.

- Graphical elements MAY be colored, and the coloring may have specified semantics that extend the information conveyed by the element as specified in this standard.
- The line style of a graphical element MAY be changed, but that change SHALL NOT conflict with any other line style required by this specification.

An extension SHALL NOT change the specified shape of a defined graphical element or marker (e.g., changing a dashed line into a plain line, changing a square into a triangle, or changing rounded corners into squared corners).

2.2.2 Decision semantics

This specification defines many semantic concepts used in defining decisions and associates them with graphical elements, markers, and connections.

To the extent that an implementation provides an interpretation of some **DMN** diagram element as a semantic specification of the associated concept, the interpretation SHALL be consistent with the semantic interpretation herein specified.

2.2.3 Attributes and model associations

This specification defines a number of attributes and properties of the semantic elements represented by the graphical elements, markers, and connections. Some attributes are specified as mandatory, but have no representation or only optional representation. And some attributes are specified as optional.

For every attribute or property that is specified as mandatory, a conforming implementation SHALL provide some mechanism by which values of that attribute or property can be created and displayed. This mechanism SHALL permit the user to create or view these values for each **DMN** element specified to have that attribute or property.

Where a graphical representation for that attribute or property is specified as required, that graphical representation SHALL be used. Where a graphical representation for that attribute or property is specified as optional, the implementation MAY use either a graphical representation or some other mechanism.

If a graphical representation is used, it SHALL be the representation specified. Where no graphical representation for that attribute or property is specified, the implementation MAY use either a graphical representation or some other mechanism. If a graphical representation is used, it SHALL NOT conflict with the specified graphical representation of any other **DMN** element.

3 References

3.1 Normative

BMM

- *Business Motivation Model (BMM), Version 1.2*, OMG Document number: formal/2014-05-01, May 2014
<http://www.omg.org/spec/BMM/1.2>

BPMN 2.0

- *Business Process Model and Notation, version 2.0*, OMG Document Number: formal/2011-01-03, January 2011
<http://www.omg.org/spec/BPMN/2.0>

IEEE 754

- *IEEE 754-2008, IEEE Standard for Floating-Point Arithmetic*, International Electrical and Electronics Engineering Society, December, 2008
<http://www.techstreet.com/ieee/searches/5835853>

ISO 8601

- *ISO 8601:2004, Data elements and interchange formats -- Information interchange -- Representation of dates and times*, International Organization for Standardization, 2004
http://www.iso.org/iso/home/store/catalogue_tc/catalogue_detail.htm?csnumber=40874

ISO EBNF

- *ISO/IEC 14977:1996, Information technology -- Syntactic metalanguage -- Extended BNF*, International Organization for Standardization, 1996
[http://standards.iso.org/ittf/PubliclyAvailableStandards/s026153_ISO_IEC_14977_1996\(E\).zip](http://standards.iso.org/ittf/PubliclyAvailableStandards/s026153_ISO_IEC_14977_1996(E).zip)

Java

- *The Java Language Specification, Java SE 7 Edition*, Oracle Corporation, February 2013
<http://docs.oracle.com/javase/specs/jls/se7/jls7.pdf>

PMML

- *Predictive Model Markup Language (PMML)*, Data Mining Group, May, 2014
<http://www.dmg.org/v4-2-1/GeneralStructure.html>

RFC 3986

- *RFC 3986: Uniform Resource Identifier (URI): Generic Syntax*. Berners-Lee, T., Fielding, R., and Masinter, L, editors. Internet Engineering Task Force, 2005. <http://www.ietf.org/rfc/rfc3986.txt>

UML

- *Unified Modeling Language (UML), v2.4.1*, OMG Document Number formal/2011-08-05, August 2011
<http://www.omg.org/spec/UML/2.4.1>

XBASE

- *XML Base (Second Edition)*. Jonathan Marsh and Richard Tobin, editors. World Wide Web Consortium, 2009.
<http://www.w3.org/TR/xmlbase/>

XML

- *Extensible Markup Language (XML) 1.0 (Fifth Edition)*, W3C Recommendation 26 November 2008
<http://www.w3.org/TR/xml/>

XML Schema

- *XML Schema Part 2: Datatypes Second Edition*, W3C Recommendation 28 October 2004
<http://www.w3.org/TR/xmlschema-2/>

XPath Data Model

- *XQuery 1.0 and XPath 2.0 Data Model (XDM) (Second Edition)*, W3C Recommendation 14 December 2010
<http://www.w3.org/TR/xpath-datamodel/>

XQuery and XPath Functions and Operators

- *XQuery 1.0 and XPath 2.0 Functions and Operators (Second Edition)*, W3C Recommendation 14 December 2010
<http://www.w3.org/TR/xpath-functions/XQuery>

3.2 Non-normative

JSON

- *ECMA-404 The JSON Data Interchange Standard*, European Computer Manufacturers Association, October, 2013
<http://www.ecma-international.org/publications/files/ECMA-ST/ECMA-404.pdf>

PRR

- *Production Rule Representation (PRR), Version 1.0*, December 2009, OMG document number formal/2009-12-01
<http://www.omg.org/spec/PRR/1.0/>

RIF

- *RIF production rule dialect*, Ch. de Sainte Marie et al. (Eds.), W3C Recommendation, 22 June 2010.
<http://www.w3.org/TR/rif-prd/>

SBVR

- *Semantics of Business Vocabulary and Business Rules (SBVR)*, V1.2, OMG document number formal/2013-11-04, November 2013
<http://www.omg.org/spec/SBVR/1.2/>

SQL

- *ISO/IEC 9075-11:2011, Information technology -- Database languages -- SQL -- Part 11: Information and Definition Schemas (SQL/Schemata)*, International Organization for Standardization, 2011
http://www.iso.org/iso/home/store/catalogue_tc/catalogue_detail.htm?csnumber=5368

XPath

- *XML Path Language (XPath) Version 1.0*, W3C Recommendation 16 November 1999
<http://www.w3.org/TR/xpath>

4 Additional Information

4.1 Acknowledgements

The following companies submitted version 1.0 of this specification:

- Decision Management Solutions
- Escape Velocity
- FICO
- International Business Machines
- Oracle

The following companies supported this specification:

- KU Leuven
- Knowledge Partners International
- Model Systems
- TIBCO

The following persons were members of the core team that contributed to the content specification: Martin Chapman, Bob Daniel, Alan Fish, Larry Goldberg, John Hall, Barbara von Halle, Gary Hallmark, Dave Ings, Christian de Sainte Marie, James Taylor, Jan Vanthienen, Paul Vincent.

In addition, the following persons contributed valuable ideas and feedback that improved the content and the quality of this specification: Bas Janssen, Robert Lario, Pete Rivett.

Version 1.1 was developed by the following persons and companies: Elie Abi-Lahoud, University College Cork; Justin Brunt, TIBCO; Alan Fish, FICO; John Hall, Rule ML Initiative; Denis Gagne, Trisotech; Gary Hallmark, Oracle; Elisa Kendall, Thematrix Partners LLC; Manfred Koethe, 88solutions; Falko Menge, Camunda Services GmbH; Zbigniew Misiak, BOC Information Technologies Consulting; Sjur Nijssen, PNA Group; Mihail Popov, MITRE; Pete Rivett, Adaptive; Bruce Silver, Bruce Silver Associates; Bastian Steinert, Signavio GmbH; Tim Stephenson, Omny Link; James Taylor, Decision Management Solutions; Jan Vanthienen, K.U. Leuven; Paul Vincent, Knowledge Partners, Inc.

4.2 IPR and Patents

The submitters contributed this work to OMG on a RF on RAND basis.

4.3 Guide to the Specification

Clause 1 summarizes the goals of the specification.

Clause 2 defines three levels of conformance with the specification: Conformance Level 1, Conformance Level 2 and Conformance Level 3.

Clause 3 lists normative references.

Clause 4 provides additional information useful in understanding the background to and structure of the specification.

Clause 5 discusses the scope and uses of **DMN** and introduces the principal concepts, including the two levels of **DMN**: the decision requirements level and the decision logic level.

Clause 6 defines the decision requirements level of **DMN**: the Decision Requirements Graph (DRG) and its notation as a Decision Requirements Diagram (DRD).

Clause 7 introduces the principles by which decision logic may be associated with elements in a DRG: i.e. how the decision requirements level and decision logic level are related to each other.

Clauses 8, 9 and 10 then define the decision logic level of **DMN**:

- Clause 8 defines the notation and syntax of Decision Tables in **DMN**
- Clause 9 defines S-FEEL: a subset of FEEL to support decision tables
- Clause 10 defines the full syntax and semantics of FEEL: the default expression language used for the Decision Logic level of **DMN**.

Clause 11 provides an example of **DMN** used to model human and automated decision-making in a simple business process.

Clause 12 addresses exchange formats and provides references to machine-readable files (XSD and XMI).

The Annexes provide non-normative background information:

- Annex A discusses the relationship between **DMN** and **BPMN**
- Annex B provides a glossary of terms.

5 Introduction to DMN

5.1 Context

The purpose of **DMN** is to provide the constructs that are needed to model decisions, so that organizational decision-making can be readily depicted in diagrams, accurately defined by business analysts, and (optionally) automated.

Decision-making is addressed from two different perspectives by existing modeling standards:

- Business process models (e.g. **BPMN**) can describe the coordination of decision-making within business processes by defining specific tasks or activities within which the decision-making takes place.
- Decision logic (e.g. PRR, PMML) can define the specific logic used to make individual decisions, for example as business rules, decision tables, or executable analytic models.

However, a number of authors (including members of the submission team) have observed that decision-making has an internal structure which is not conveniently captured in either of these modeling perspectives. Our intention is that **DMN** will provide a third perspective – the Decision Requirements Diagram – forming a bridge between business process models and decision logic models:

- Business process models will define tasks within business processes where decision-making is required to occur
- Decision Requirements Diagrams will define the decisions to be made in those tasks, their interrelationships, and their requirements for decision logic
- Decision logic will define the required decisions in sufficient detail to allow validation and/or automation.

Taken together, Decision Requirements Diagrams and decision logic can provide a complete decision model which complements a business process model by specifying in detail the decision-making carried out in process tasks. The relationships between these three aspects of modeling are shown in Figure 1.

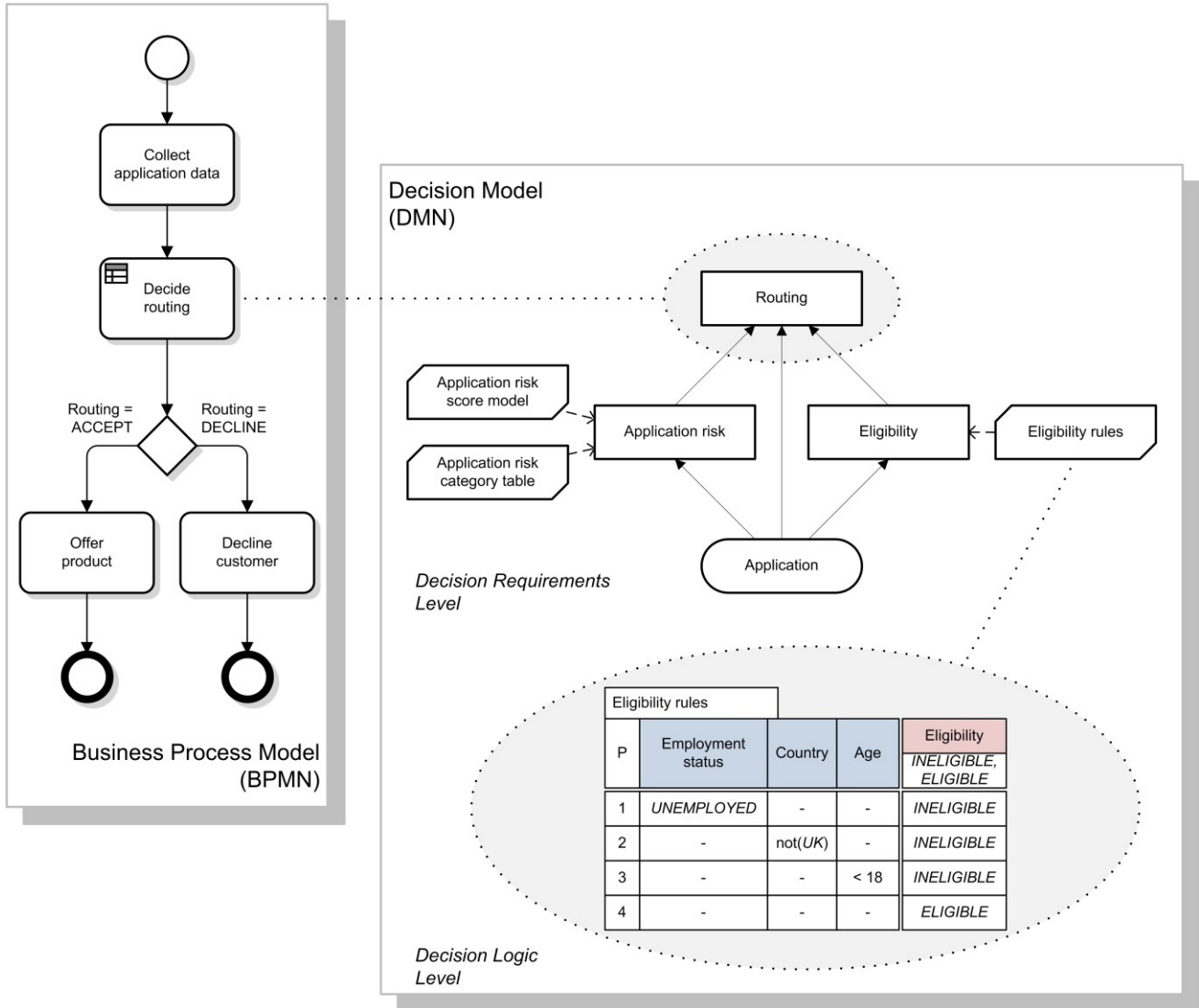

Figure 1: Aspects of modeling

The resulting connected set of models will allow detailed modeling of the role of business rules and analytic models in business processes, cross-validation of models, top-down process design and automation, and automatic execution of decision-making (e.g. by a business process management system calling a decision service deployed from a business rules management system).

Although Figure 1 shows a linkage between a business process model and a decision model for the purposes of explaining the relationship between **DMN** and other standards, it must be stressed that **DMN** is not dependent on **BPMN**, and its two levels – decision requirements and decision logic – may be used independently or in conjunction to model a domain of decision-making without any reference to business processes (see clause 5.2).

DMN will provide constructs spanning both decision requirements and decision logic modeling. For decision requirements modeling, it defines the concept of a Decision Requirements Graph (DRG) comprising a set of elements and their connection rules, and a corresponding notation: the Decision Requirements Diagram (DRD). For decision logic modeling it provides a language called FEEL for defining and assembling decision tables, calculations, if/then/else logic, simple data structures, and externally defined logic from Java and PMML into executable expressions with formally defined semantics. It also provides a notation for decision logic (“boxed expressions”) allowing components of the decision logic level to be

drawn graphically and associated with elements of a Decision Requirements Diagram. The relationship between these constructs is shown in Figure 2.

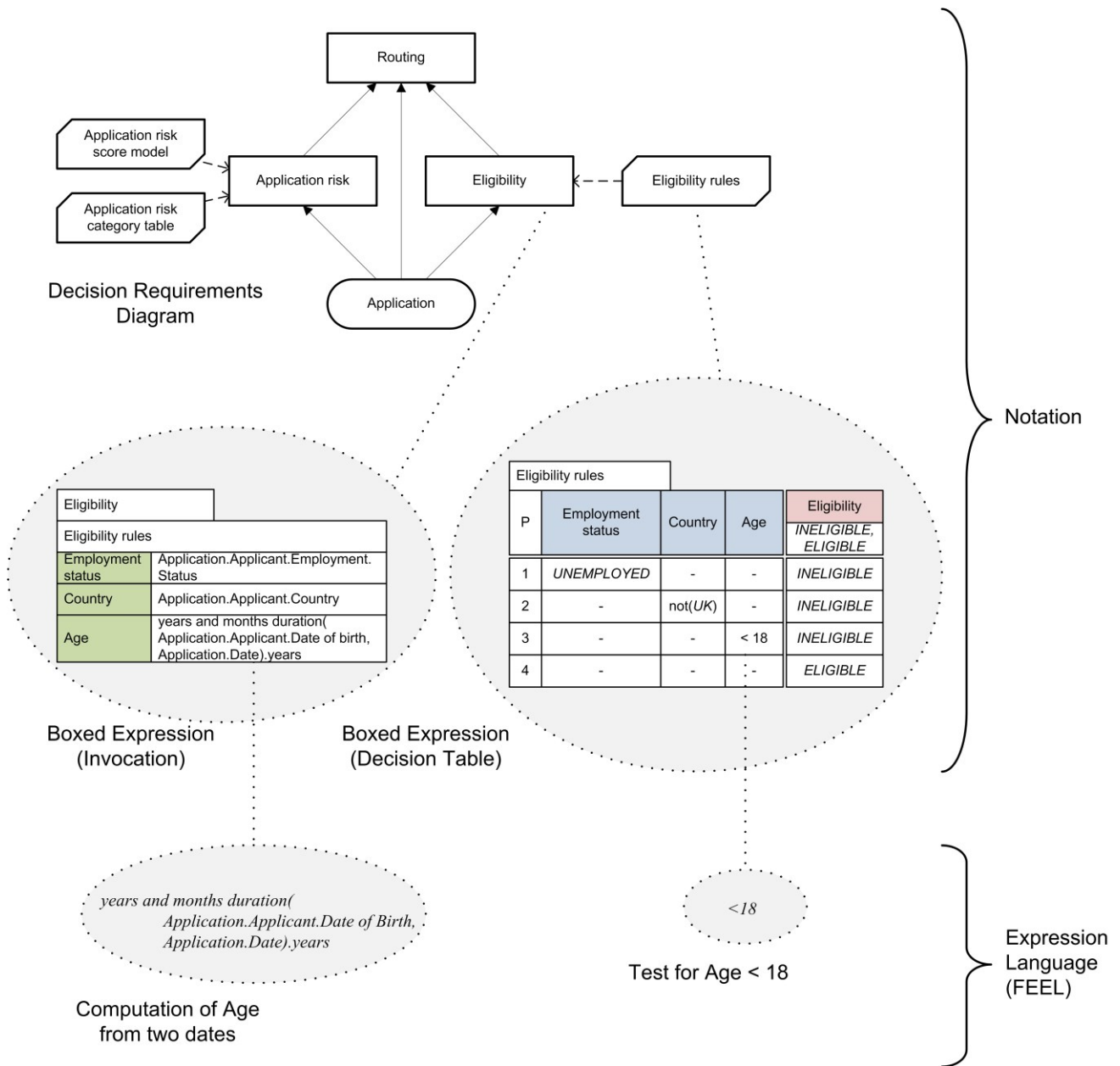

Figure 2: DMN Constructs

5.2 Scope and uses of DMN

Decision modeling is carried out by business analysts in order to understand and define the decisions used in a business or organization. Such decisions are typically operational decisions made in day-to-day business processes, rather than the strategic decision-making for which fewer rules and representations exist.

Three uses of **DMN** can be discerned in this context:

1. For modeling human decision-making
2. For modeling the requirements for automated decision-making
3. For implementing automated decision-making.

5.2.1 Modeling human decision-making

DMN may be used to model the decisions made by personnel within an organization. Human decision-making can be broken down into a network of interdependent constituent decisions, and modeled using a DRD. The decisions in the DRD would probably be described at quite a high level, using natural language rather than decision logic.

Knowledge sources may be defined to model governance of decision-making by people (e.g. a manager), regulatory bodies (e.g. an ombudsman), documents (e.g. a policy booklet) or bodies of legislation (e.g. a government statute). These knowledge sources may be linked together, for example to show that a decision is governed (a) by a set of regulations defined by a regulatory body, and (b) by a company policy document maintained by a manager.

Business knowledge models may be used to represent specific areas of business knowledge drawn upon when making decisions. This will allow **DMN** to be used as a tool for formal definition of requirements for knowledge management. Business knowledge models may be linked together to show the interdependencies between areas of knowledge (in a manner similar to that used in the existing technique of [Knowledge Structure Mapping](#)). Knowledge sources may be linked to the business knowledge models to indicate how the business knowledge is governed or maintained, for example to show that a set of business policies (the business knowledge model) is defined in a company policy document (the knowledge source).

In some cases it may be possible to define specific rules or algorithms for the decision-making. These may be modeled using decision logic (e.g. business rules or decision tables) to specify business knowledge models in the DRD, either descriptively (to record how decisions are currently made, or how they were made during a particular period of observation) or prescriptively (to define how decisions should be made, or will be made in the future).

Decision-making modeled in **DMN** may be mapped to tasks or activities within a business process modeled using **BPMN**. At a high level, a collaborative decision-making task may be mapped to a subset of decisions in a DRD representing the overall decision-making behavior of a group or department. At a more detailed level, it is possible to model the interdependencies between decisions made by a number of individuals or groups using **BPMN** collaborations: each participant in the decision-making is represented by a separate pool in the collaboration and a separate DRD in the decision model. Decisions in those DRDs are then mapped to tasks in the pools, and input data in the DRDs are mapped to the content of messages passing between the pools.

The combined use of **BPMN** and **DMN** thus provides a graphical language for describing multiple levels of human decision-making within an organization, from activities in business processes down to a detailed definition of decision logic. Within this context **DMN** models will describe collaborative organizational decisions, their governance, and the business knowledge required for them.

5.2.2 Modeling requirements for automated decision-making

The use of **DMN** for modeling the requirements for automated decision-making is similar to its use in modeling human decision-making, except that it is entirely prescriptive, rather than descriptive, and there is more emphasis on the detailed decision logic.

For full automation of decisions, the decision logic must be complete, i.e. capable of providing a decision result for any possible set of values of the input data.

However, partial automation is more common, where some decision-making remains the preserve of personnel. Interactions between human and automated decision-making may be modeled using collaborations as above, with separate pools for human and automated decision-makers, or more simply by allocating the decision-making to separate tasks in the business process model, with user tasks for human decision-making and business rule tasks for automated decision-making. So, for example, an automated business rules task might decide to refer some cases to a human reviewer; the decision logic for the automated task needs to be specified in full but the reviewer's decision-making could be left unspecified.

Once decisions in a DRD are mapped to tasks in a **BPMN** business process flow, it is possible to validate across the two levels of models. For example, it is possible to verify that all input data in the DRDs are provided by previous tasks in the business process, and that the business process uses the results of decisions only in subsequent tasks or gateways. **DMN** models the relationships between Decisions and Business Processes so that the Decisions that must be made for a Business Process to complete can be identified and so that the specific decision-making tasks that perform or execute a Decision can be specified. No formal mapping of **DMN** `ItemDefinition` or **DMN** `InputData` to **BPMN** `DataObject` is proposed but an implementation could include such a check in a situation where such a mapping could be determined.

Together, **BPMN** and **DMN** therefore allow specification of the requirements for automated decision-making and its interaction with human decision making within business processes. These requirements may be specified at any level of detail, or at all levels. The three-tier mapping between business process models, DRDs and decision logic will allow the definition of these requirements to be supported by model-based computer-aided design tools.

5.2.3 Implementing automated decision-making

If all decisions and business knowledge models are fully specified using decision logic, it becomes possible to execute decision models.

One possible scenario is the use of “decision services” deployed from a Business Rules Management System (BRMS) and called by a Business Process Management System (BPMS). A decision service encapsulates the decision logic supporting a DRD, providing interfaces that correspond to subsets of input data and decisions within the DRD. When called with a set of input data, the decision service will evaluate the specified decisions and return their results. The constraint in **DMN** that all decision logic is free of side-effects means that decision services will comply with SOA principles, simplifying system design.

The structure of a decision model, as visualized in the DRD, may be used as a basis for planning an implementation project. Specific project tasks may be included to cover the definition of decision logic (e.g. rule discovery using human experts, or creation of analytic models), and the implementation of components of the decision model.

Some decision logic representing the business knowledge encapsulated in decision services needs to be maintained over time by personnel responsible for the decisions, using special “knowledge maintenance interfaces”. **DMN** supports the effective design and implementation of knowledge maintenance interfaces: any business knowledge requiring maintenance should be modeled as business knowledge models in the DRD, and the responsible personnel as knowledge sources. DRDs then provide a specification of the required knowledge maintenance interfaces and their users, and the decision logic specifies the initial configuration of the business knowledge to be maintained.

Other decision logic needs to be refreshed by regular analytic modeling. The representation of business knowledge models as functions in **DMN** makes the use of analytic models in decision services very simple: any analytic model capable of representation as a function may be directly called by or imported into a decision service.

5.2.4 Combining applications of modeling

The three contexts described above are not mutually exclusive alternatives; a large process automation project might use **DMN** in all three ways.

First, the decision-making within the existing process might be modeled, to identify the full extent of current decision making and the areas of business knowledge involved. This “as-is” analysis provides the baseline for process improvement.

Next, the process might be redesigned to make the most effective use of both automated and human decision-making, often using collaboration between the two (e.g. using automated referrals to human decision-makers, or decision support systems which advise or constrain the user). Such a redesign involves modeling the requirements for the decision-making to occur in each process task and the roles and responsibilities of individuals or groups in the organization. This model provides a “to-be” specification of the required process and the decision-making it coordinates.

Comparison of the “as-is” and “to-be” models will indicate requirements not just for automation technology, but for change management: changes in the roles and responsibilities of personnel, and training to support new or modified business knowledge.

Finally, the “to-be” model will be implemented as executable system software. Provided the decision logic is fully specified in FEEL and/or other external logic (e.g. externally defined Java methods or PMML models), components of the decision model may be implemented directly as software components.

DMN does not prescribe any particular methodology for carrying out the above activities; it only supports the models used for them.

5.3 Basic concepts

5.3.1 Decision requirements level

The word “decision” has two definitions in common use: it may denote the act of choosing among multiple possible options; or it may denote the option that is chosen. In this specification, we adopt the former usage: a **decision** is the act of determining an **output** value (the chosen option), from a number of **input** values, using logic defining how the output is determined from the inputs. This **decision logic** may include one or more **business knowledge models** which encapsulate business know-how in the form of business rules, analytic models, or other formalisms. This basic structure, from which all decision models are built, is shown in Figure 3.

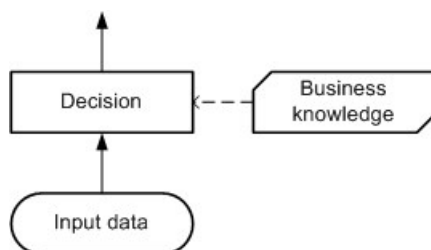

Figure 3: Basic elements of a decision model

For simplicity and generality, many of the figures in this specification show each decision as having a single associated business knowledge model, but it should be noted that **DMN** does not require this to be the case. The use of business knowledge models to encapsulate decision logic is a matter of style and methodology, and decisions may be modeled with no associated business knowledge models, or with several.

Authorities may be defined for decisions or business knowledge models, which might be (for example) domain experts responsible for defining or maintaining them, or source documents from which business knowledge models are derived, or sets of test cases with which the decisions must be consistent. These are called **knowledge sources** (see Figure 4).

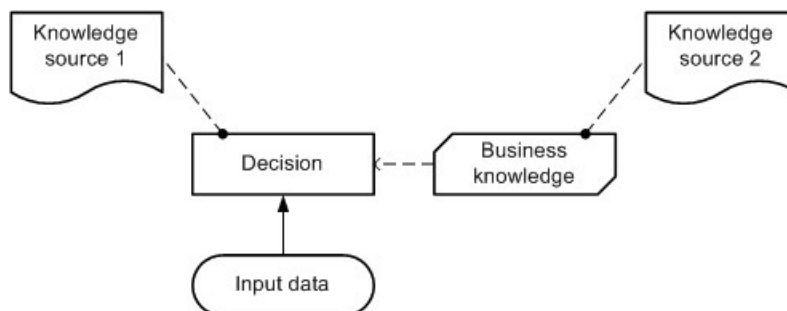

Figure 4: Knowledge sources

A decision is said to “require” its inputs in order to determine its output. The inputs may be **input data**, or the outputs of other decisions. (In either case they may be data structures, rather than just simple data items.) If the inputs of a decision Decision1 include the output of another decision Decision2, Decision1 “requires” Decision2. Decisions may therefore be connected in a network called a **Decision Requirements Graph (DRG)**, which may be drawn as a **Decision Requirements Diagram (DRD)**. A DRD shows how a set of decisions depend on each other, on input data, and on business knowledge models. A simple example of a DRD with only two decisions is shown in Figure 5.

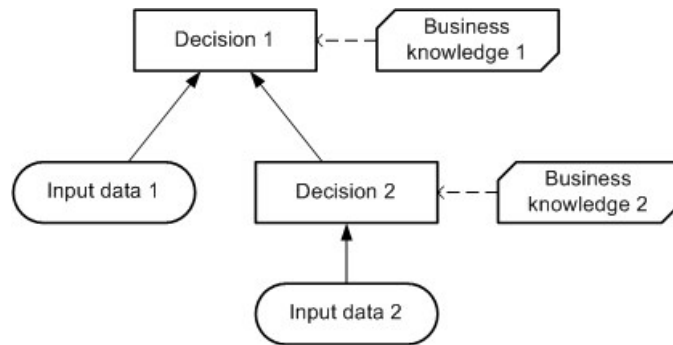

Figure 5: A simple Decision Requirements Diagram (DRD)

A decision may require multiple business knowledge models, and a business knowledge model may require multiple other business knowledge models, as shown in Figure 6. This will allow (for example) the modeling of complex decision logic by combining diverse areas of business knowledge, and the provision of alternative versions of decision logic for use in different situations.

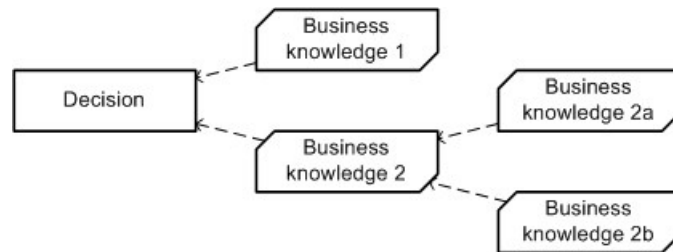

Figure 6: Combining business knowledge models

DRGs and their notation as DRDs are specified in detail in clause 6.

5.3.2 Decision logic level

The components of the decision requirements level of a decision model may be described, as they are above, using only business concepts. This level of description is often sufficient for business analysis of a domain of decision-making, to identify the business decisions involved, their interrelationships, the areas of business knowledge and data required by them, and the sources of the business knowledge. Using decision logic, the same components may be specified in greater detail, to capture a complete set of business rules and calculations, and (if desired) to allow the decision-making to be fully automated.

Decision logic may also provide additional information about how to display elements in the decision model. For example, the decision logic element for a decision table may specify whether to show the rules as rows or as columns. The decision logic element for a calculation may specify whether to line up terms vertically or horizontally.

The correspondence between concepts at the decision requirements level and the decision logic level is described below. Please note that in the figures below, as in Figure 1 and Figure 2, the grey ellipses and dotted lines are drawn only to indicate correspondences between concepts in different levels for the purposes of this introduction. They do *not* form part of the notation of **DMN**, which is formally defined in clauses 6.2, 8.2 and 10.2. It is envisaged that implementations will provide facilities for moving between levels of modeling, such as “opening”, “drilling down” or “zooming in”, but **DMN** does not specify how this should be done.

At the decision logic level, every decision in a DRG is defined using a **value expression** which specifies how the decision’s output is determined from its inputs. At that level, the decision is considered to *be* the evaluation of the expression. The value expression may be notated using a **boxed expression**, as shown in Figure 7.

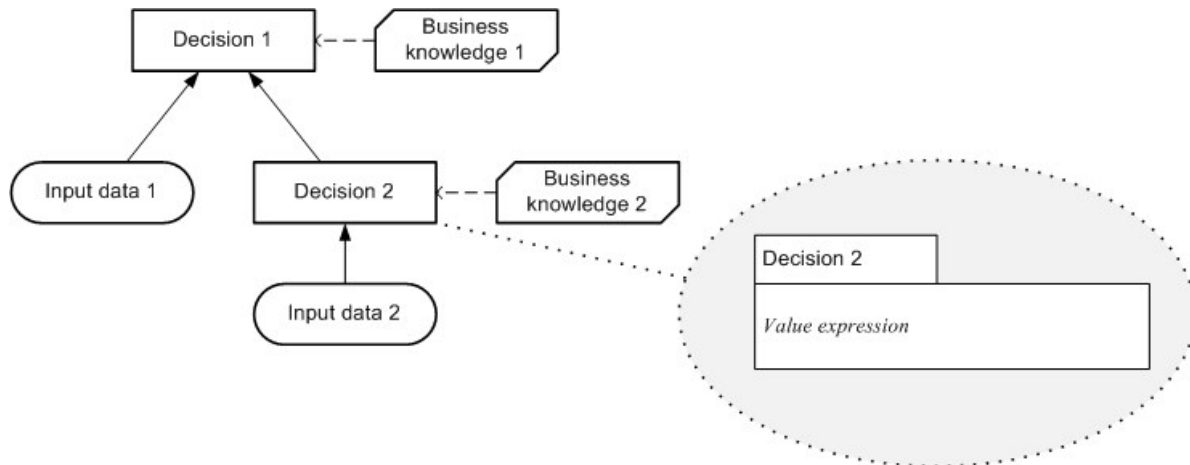

Figure 7: Decision and corresponding value expression

In the same way, at the decision logic level, a business knowledge model is defined using a value expression that specifies how an output is determined from a set of inputs. In a business knowledge model, the value expression is encapsulated as a function definition, which may be invoked from a decision's value expression. The interpretation of business knowledge models as functions in **DMN** means that the combination of business knowledge models as in Figure 6 has the clear semantics of functional composition. The value expression of a business knowledge model may be notated using a **boxed function** definition, as shown in Figure 8.

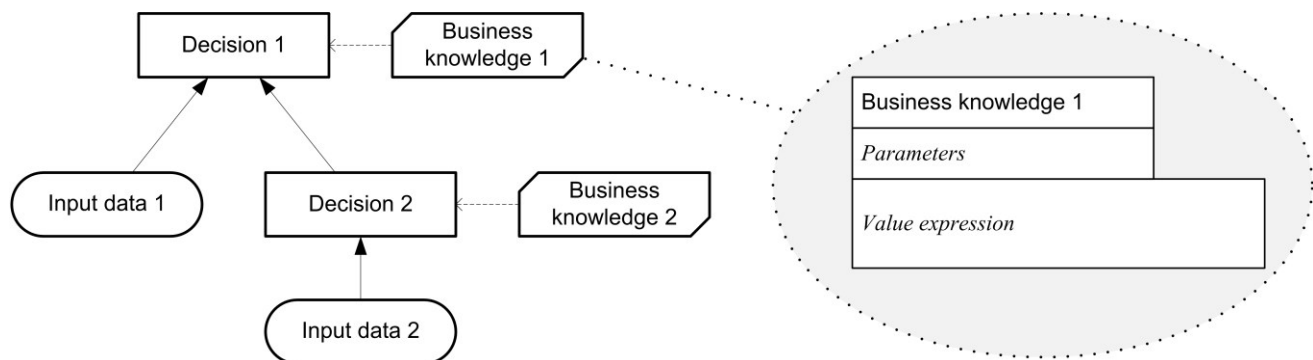

Figure 8: Business knowledge model and corresponding value expression

A business knowledge model may contain any decision logic which is capable of being represented as a function. This will allow the import of many existing decision logic modeling standards (e.g. for business rules and analytic models) into **DMN**.

An important format of business knowledge, specifically supported in **DMN**, is the Decision Table. Such a business knowledge model may be notated using a **Decision Table**, as shown in Figure 9.

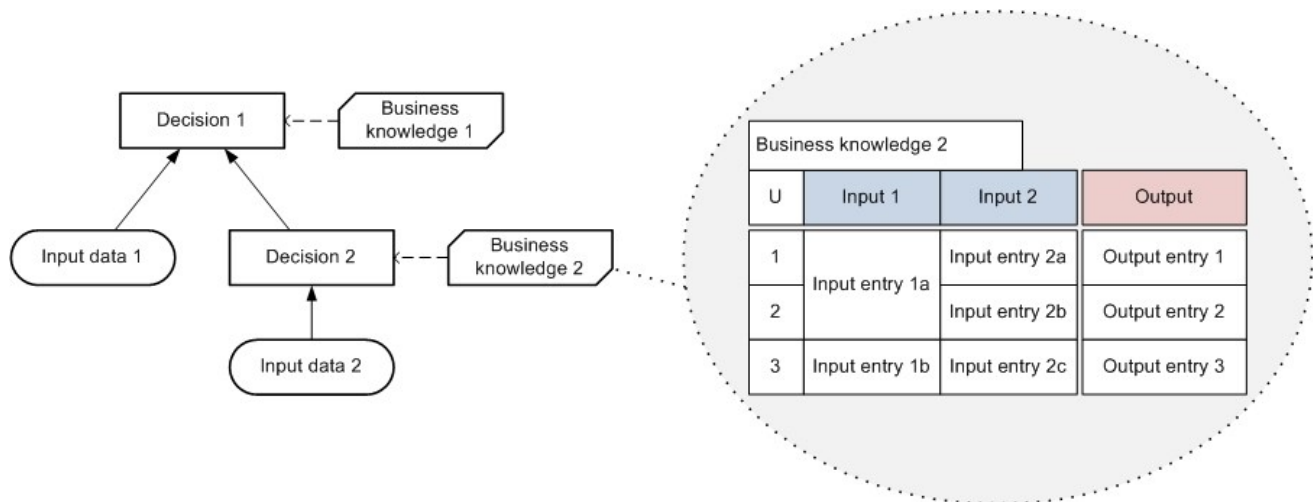

Figure 9: Business knowledge model and corresponding decision table

In most cases, the logic of a decision is encapsulated into business knowledge models, and the value expression associated with the decision specifies how the business knowledge models are invoked, and how the results of their invocations are combined to compute the output of the decision. The decision's value expression may also specify how the output is determined from its input entirely within itself, without invoking a business knowledge model: in that case, no business knowledge model is associated with the decision (neither at the decision requirements level nor at the decision logic level).

An expression language for defining decision logic in **DMN**, covering all the above concepts, is specified fully in clause 10. This is **FEEL**: the Friendly Enough Expression Language. The notation for Decision Tables is specified in detail in clause 8.

5.3.3 Decision services

One important use of **DMN** will be to define decision-making logic to be automated using "decision services". A decision service exposes one or more decisions from a decision model as a service, which might be consumed (for example) by a task in a **BPMN** process model. When the service is called, with the necessary input data and decision results, it returns the outputs of the exposed decisions. Any decision service encapsulating a **DMN** decision model will be stateless and have no side effects. It might be implemented, for example, as a web service. **DMN** does not specify how such services should be implemented, but it allows the functionality of a service to be defined against a decision model.

It is assumed that the client requires a certain set of decisions to be made, and that the service is created to meet that requirement. The sole function of the decision service is to return the results of evaluating that set of decisions (the "output decisions"). The service may be provided with the results of decisions evaluated externally to the service (the "input decisions"). The service must encapsulate not just the output decisions but also any decisions in the DRG directly or indirectly required by the output decisions which are not provided in the input decisions (the "encapsulated decisions").

The interface to the decision service will consist of:

- Input data: instances of all the input data required by the encapsulated decisions
- Input decisions: instances of the results of all the input decisions
- Output decisions: the results of evaluating (at least) all the output decisions, using the provided input decisions and input data.

When the service is called, providing the input data and input decisions, it returns the output decisions.

Note that to define a decision service it is only necessary to specify the output decisions and either the input decisions or the encapsulated decisions. The remaining attributes (the required input data, and whichever of the encapsulated or input decisions was not specified) may then be inferred from the decision model against which the service is defined. Alternatively, if more attributes are defined than are strictly necessary, they may be validated against the decision model.

Figure 10 shows a decision service defined against a decision model that includes three decisions. The output decisions for this service are {Decision 1}, and the input decisions are {}, that is, the service returns the result of Decision 1 and is not provided with the results of any external decisions. Since Decision 1 requires Decision 2, which is not provided to the service as input, the service must also encapsulate Decision 2. Decision 3 is not required to be encapsulated. The encapsulated decisions are therefore {Decision 1, Decision 2}. The service requires Input data 1 and Input data 2, but not Input data 3.

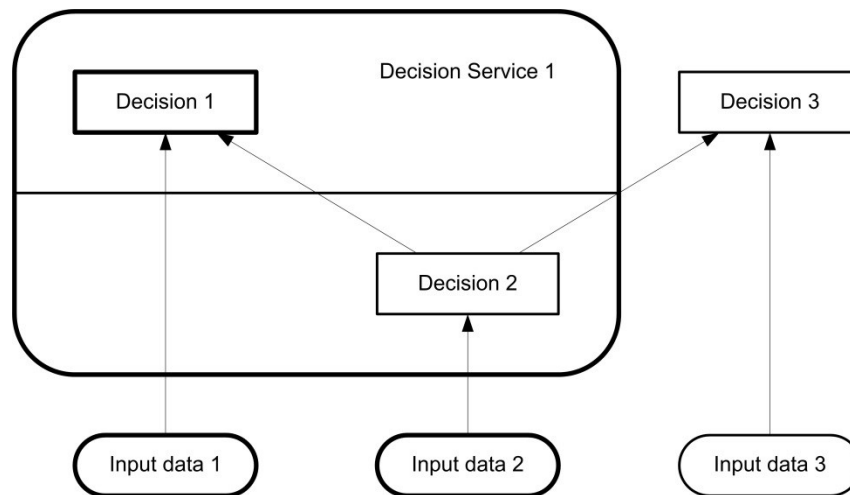

Figure 10: A decision service

Multiple decision services may be defined against the same decision model. Figure 11 shows a decision service defined against the same decision model, whose output decisions are {Decision 1} and whose input decisions are {Decision 2}. The encapsulated decisions for this service are {Decision 1}. The service requires Input data 1, but not Input data 2 or Input data 3.

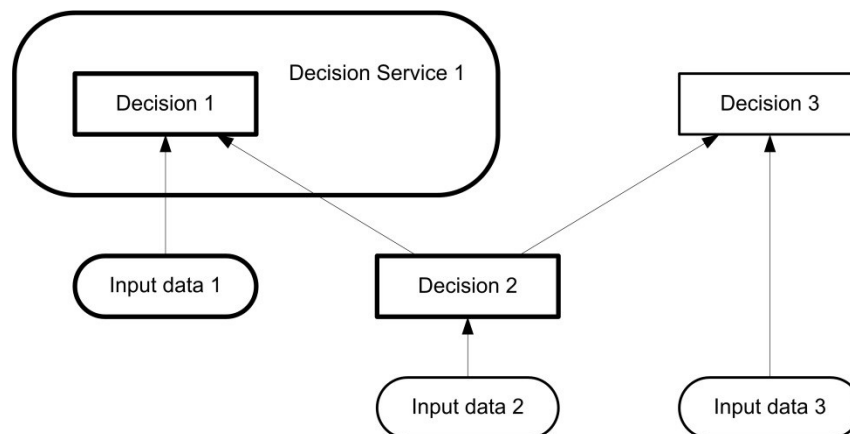

Figure 11: A decision service taking a decision as input

In its simplest form a decision service would always evaluate all the decisions in the output set set and return all their results. For computational efficiency various improvements to this basic interpretation can be imagined, e.g.

- An optional input parameter specifying a list of “requested decisions” (a subset of the minimal output set). Only the results of the requested decisions would be returned in the output context.
- An optional input parameter specifying a list of “known decisions” (a subset of the encapsulation set), with their results. The decision service would not evaluate these decisions, but would use the provided input values directly.

All such implementation details are left to the software provider.

A decision service is “complete” if it contains decision logic for evaluating all the encapsulated decisions on all possible input data values. A request to the service is “valid” if instances are provided for all the input decisions and input data required by those decisions which need to be evaluated, i.e. (in the simple case) all the encapsulated decisions, or (assuming the optional parameters above) any requested decisions and their required sub-decisions which are not already known.

6 Requirements (DRG and DRD)

6.1 Introduction

The decision requirements level of a decision model in **DMN** consists of a Decision Requirements Graph (DRG) depicted in one or more Decision Requirements Diagrams (DRDs).

A DRG models a domain of decision-making, showing the most important elements involved in it and the dependencies between them. The elements modeled are decisions, areas of business knowledge, sources of business knowledge, and input data:

- A **Decision** element denotes the act of determining an output from a number of inputs, using decision logic which may reference one or more Business Knowledge Models.
- A **Business Knowledge Model** element denotes a function encapsulating business knowledge, e.g. as business rules, a decision table, or an analytic model.
- An **Input Data** element denotes information used as an input by one or more Decisions.
- A **Knowledge Source** element denotes an authority for a Business Knowledge Model or Decision.

The dependencies between these elements express three kinds of requirements: information, knowledge and authority:

- An **Information Requirement** denotes Input Data or Decision output being used as input to a Decision.
- A **Knowledge Requirement** denotes the invocation of a Business Knowledge Model by the decision logic of a Decision.
- An **Authority Requirement** denotes the dependence of a DRG element on another DRG element that acts as a source of guidance or knowledge.

DRDs may also contain any number of artifacts representing annotations of the diagram:

- A Text Annotation is modeler-entered text used for comment or explanation.
- An Association is a dotted connector used to link a Text Annotation to a DRG Element.





These components are summarized in Table 1 and described in more detail in clause 6.2.

A DRG is a graph composed of elements connected by requirements, and is self-contained in the sense that all the modeled requirements for any Decision in the DRG (its immediate sources of information, knowledge and authority) are present in the same DRG. It is important to distinguish this complete definition of the DRG from a DRD presenting any particular view of it, which may be a partial or filtered display: see clause 6.2.4.

6.2 Notation

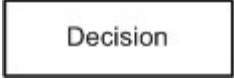
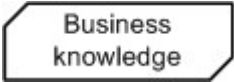
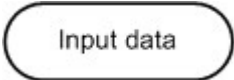
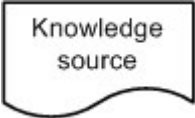
The notation for all components of a DRD is summarized in Table 1 and described in more detail below.

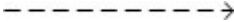
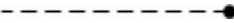
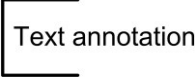
Table 1: DRD components

Component		Description	Notation
Elements	Decision	A decision denotes the act of determining an output from a number of inputs, using decision logic which may reference one or more business knowledge models.	
	Business Knowledge Model	A business knowledge model denotes a function encapsulating business knowledge, e.g. as business rules, a decision table, or an analytic model.	
	Input Data	An input data element denotes information used as an input by one or more decisions. When enclosed within a knowledge model, it denotes the parameters to the knowledge model.	
	Knowledge Source	A knowledge source denotes an authority for a business knowledge model or decision.	
Requirements	Information Requirement	An information requirement denotes input data or a decision output being used as one of the inputs of a decision	
	Knowledge Requirement	A knowledge requirement denotes the invocation of a business knowledge model	
	Authority Requirement	An authority requirement denotes the dependence of a DRD element on another DRD element that acts as a source of guidance or knowledge	
Artifacts	Text Annotation	A Text Annotation consists of a square bracket followed by modeler-entered explanatory text or comment	
	Association	An Association connector links a Text Annotation to the DRG Element it explains or comments on	

6.2.1 DRD Elements

6.2.1.1 Decision notation

A Decision is represented in a DRD as a rectangle, normally drawn with solid lines, as shown in Table 1. Implementations SHALL be able to label each Decision by displaying its Name, and MAY be able to label it by displaying other properties such as its Question or Description. If displayed, the label SHALL be different from the labels of all the DRD elements in the same DRD and SHALL be clearly inside the shape of the DRD element.

If the Listed Input Data option is exercised (see 6.2.1.3), all the Decision's requirements for Input Data SHALL be listed beneath the Decision's label and separated from it by a horizontal line, as shown in Figure 12. The listed Input Data names SHALL be clearly inside the shape of the DRD element.

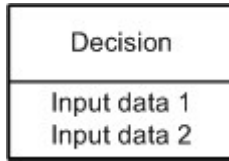

Figure 12: Decision with Listed Input Data option

The properties of a Decision are listed and described in 6.3.6.

6.2.1.2 Business Knowledge Model notation

A Business Knowledge Model is represented in a DRD as a rectangle with two clipped corners, normally drawn with solid lines, as shown in Table 1. Implementations SHALL be able to label each Business Knowledge Model by displaying its Name, and MAY be able to label it by displaying other properties such as its Description. If displayed, the label SHALL be different from the labels of all the DRD elements in the same DRD and SHALL be clearly inside the shape of the DRD element.

The properties of a Business Knowledge Model are listed and described in 6.3.8.

6.2.1.3 Input Data notation

An Input Data element is represented in a DRD as a shape with two parallel straight sides and two semi-circular ends, normally drawn with solid lines, as shown in Table 1. Implementations SHALL be able to label each Input Data element by displaying its Name, and MAY be able to label it by displaying other properties such as its Description. If displayed, the label SHALL be different from the labels of all the DRD elements in the same DRD and SHALL be clearly inside the shape of the DRD element.

An alternative compliant way to display requirements for Input Data, especially useful when DRDs are large or complex, is that Input Data are not drawn as separate notational elements in the DRD, but are instead listed on those Decision elements which require them. For convenience in this specification this is called the “Listed Input Data” option. Implementations MAY offer this option. Figure 13 shows two equivalent DRDs, one drawing Input Data elements, the other exercising the Listed Input Data option. Note that if an Input Data element is not displayed it SHALL be listed on all Decisions which require it (unless it is deliberately hidden as discussed in 6.2.4).

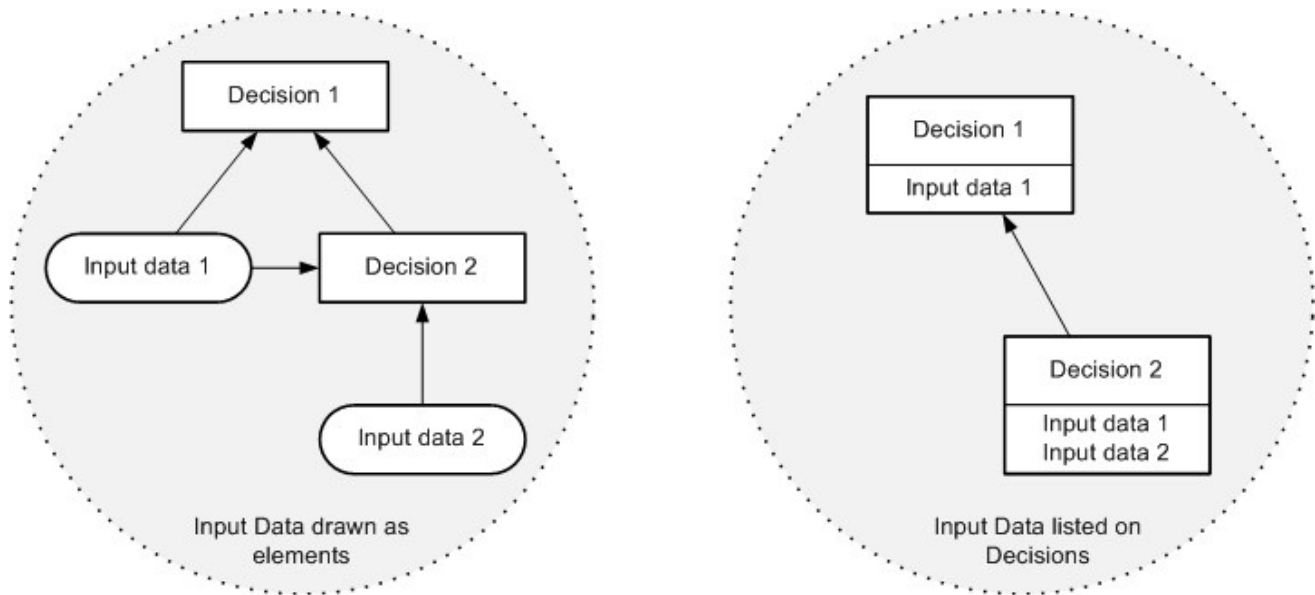

Figure 13: The Listed Input Data option

The properties of an Input Data element are listed and described in 6.3.10.

6.2.1.4 Knowledge Source notation

A Knowledge Source is represented in a DRD as a shape with three straight sides and one wavy one, normally drawn with solid lines, as shown in Table 1. Implementations SHALL be able to label each Knowledge Source element by displaying its Name, and MAY be able to label it by displaying other properties such as its Description. If displayed, the label SHALL be different from the labels of all the DRD elements in the same DRD and SHALL be clearly inside the shape of the DRD element.

The properties of a Knowledge Source element are listed and described in 6.3.11.

6.2.2 DRD Requirements

6.2.2.1 Information Requirement notation

Information Requirements may be drawn from Input Data elements to Decisions, and from Decisions to other Decisions. They represent the dependency of a Decision on information from input data or the results of other Decisions. They may also be interpreted as data flow: a DRD displaying only Decisions, Input Data and Information Requirements is equivalent to a dataflow diagram showing the communication of information between those elements at evaluation time. The Information Requirements of a valid DRG form a directed acyclic graph.

An Information Requirement is represented in a DRD as an arrow drawn with a solid line and a solid arrowhead, as shown in Table 1. The arrow is drawn in the direction of information flow, i.e. towards the Decision that requires the information.

6.2.2.2 Knowledge Requirement notation

Knowledge Requirements may be drawn from Business Knowledge Models to Decisions, and from Business Knowledge Models to other Business Knowledge Models. They represent the invocation of business knowledge when making a decision. They may also be interpreted as function calls: a DRD displaying only Decisions, Business Knowledge Models and Knowledge Requirements is equivalent to a function hierarchy showing the function calls involved in evaluating the Decisions. The Knowledge Requirements of a valid DRG form a directed acyclic graph.

A Knowledge Requirement is represented in a DRD as an arrow drawn with a dashed line and an open arrowhead, as shown in Table 1. The arrows are drawn in the direction of the information flow of the result of evaluating the function, i.e. toward the element that requires the business knowledge.

6.2.2.3 Authority Requirement notation

Authority Requirements may be used in two ways:

- a) They may be drawn from Knowledge Sources to Decisions, Business Knowledge Models and other Knowledge Sources, where they represent the dependence of the DRD element on the knowledge source. This might be used to record the fact that a set of business rules must be consistent with a published document (e.g. a piece of legislation or a statement of business policy), or that a specific person or organizational group is responsible for defining some decision logic, or that a decision is managed by a person or group. An example of this use of Knowledge Sources is shown in Figure 14: in this case the Business Knowledge Model requires two sources of authority – a policy document and legislation – and the policy document requires the authority of a policy group.

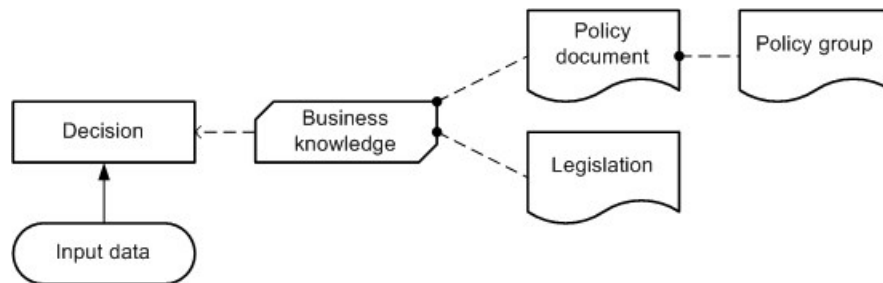

Figure 14: Knowledge Sources representing authorities

- b) They may be drawn from Input Data and Decisions to Knowledge Sources, where, in conjunction with use (a), they represent the derivation of Business Knowledge Models from instances of Input Data and Decision results, using analytics. The Knowledge Source typically represents the analytic model (or modeling process); the Business Knowledge Model represents the executable logic generated from or dependent on the model. An example of this use of a Knowledge Source is shown in Figure 15: in this case a business knowledge model is based on an analytic model which is derived from input data and the results of a dependent decision.

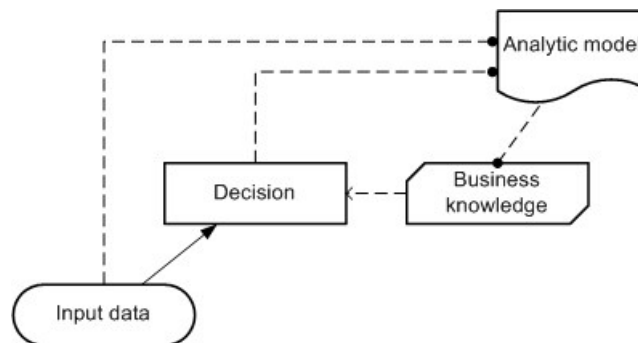

Figure 15: Knowledge source representing predictive analytics

However, the figures above are only examples. There are many other possible use cases for Authority Requirements (and since Knowledge Sources and Authority Requirements have no execution semantics their interpretation is necessarily vague), so this specification leaves the details of their application to the implementer.

An Authority Requirement is represented in a DRD as an arrow drawn with a dashed line and a filled circular head, as shown in Table 1. The arrows are drawn from the source of authority to the element governed by it.

6.2.3 Connection rules

The rules governing the permissible ways of connecting elements with requirements in a DRD are described in Clause 6.2.2 above and summarized in Table 2. For clarity, a simple DRD is shown for each permissible connection. In each of these diagrams, the upper (“to”) element requires the lower (“from”) element.

Note that no requirements may be drawn terminating in Input Data, that is, input data may have no requirements. Note also that the type of the requirement is uniquely determined by the types of the two elements connected.

Table 2: Requirements connection rules

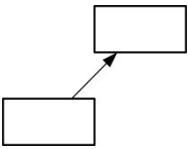
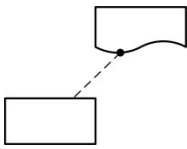
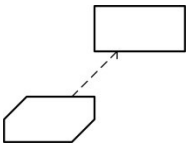
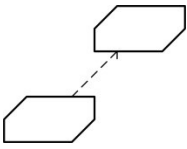
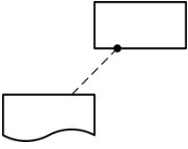
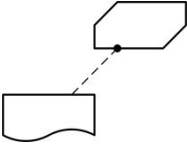
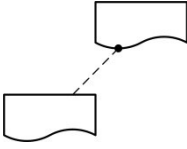
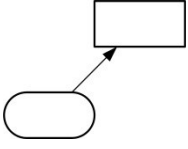
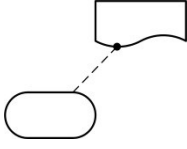
		To			
		Decision	Business Knowledge Model	Knowledge Source	Input Data
From	Decision	 Information Requirement	not allowed	 Authority Requirement	not allowed
	Business Knowledge Model	 Knowledge Requirement	 Knowledge Requirement	not allowed	not allowed
	Knowledge Source	 Authority Requirement	 Authority Requirement	 Authority Requirement	not allowed
	Input Data	 Information Requirement	not allowed	 Authority Requirement	not allowed

6.2.4 Partial views and hidden information

The metamodel (see clause 6.3) provides properties for each of the DRG elements which would not normally be displayed on the DRD, but provide additional information about their nature or function. For example, for a Decision these include properties specifying which **BPMN** processes and tasks make use of the Decision. Implementations **SHALL** provide facilities for specifying and displaying such properties.

For any significant domain of decision-making a DRD representing the complete DRG may be a large and complex diagram. Implementations **MAY** provide facilities for displaying DRDs which are partial or filtered views of the DRG, e.g. by hiding categories of elements, or hiding or collapsing areas of the network. **DMN** does not specify how such views should be notated, but whenever information is hidden implementations **SHOULD** provide a clear visual indication that this is the case.

Two examples of DRDs providing partial views of a DRG are shown in Figure 16: DRD 1 shows only the immediate requirements of a single decision; DRD 2 shows only Information Requirements and the elements they connect. In this example, for the purposes of illustration only, the approach taken is to use a fine dashed outline for any element with some hidden requirements.

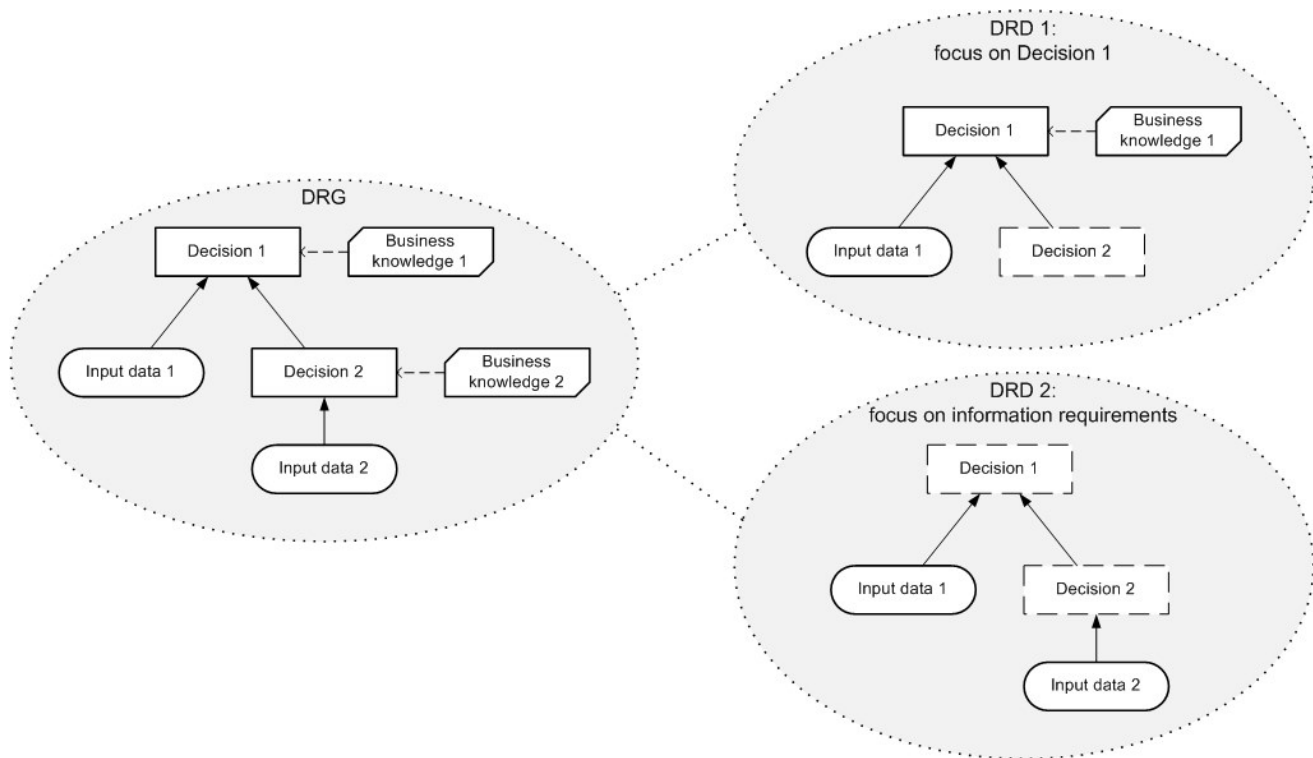

Figure 16: DRDs as partial views of a DRG

DRDs are not represented in the metamodel and may therefore not be interchanged; a set of definitions comprising a DRG may be interchanged, and the recipient may generate any desired DRD from them which is supported by the receiving implementation.

6.2.5 Decision service

A Decision Service is represented in a DRD as rectangle with rounded corners, drawn with a heavy solid border. Implementations **SHALL** be able to label each Decision Service by displaying its name, and **MAY** be able to label it by displaying other properties such as its Description. If displayed, the label **SHALL** be different from the labels of all the

DRD elements in the same DRD and SHALL be clearly inside the rectangle. The border SHALL enclose all the encapsulated decisions, and no other decisions or input data. The border MAY enclose other DRG elements but these will not form part of the definition of the Decision Service.

If the set of output decisions is smaller than the set of encapsulated decisions, the Decision Service SHALL be divided into two parts with a straight solid line. One part SHALL enclose only the output decisions and the label; the other part SHALL enclose all the encapsulated decisions which are not in the set of output decisions. Either part MAY enclose other DRG elements but these will not form part of the definition of the Decision Service.

For clarity, the rectangle or its parts MAY be shaded, and all the elements comprising its interface (the output decisions, input decisions and input data) MAY be drawn with a line that matches the weight and colour of the border. Figure 17 shows a Decision Service with two output decisions; other examples (with a single output decision) are shown in Figure 10 and Figure 11.

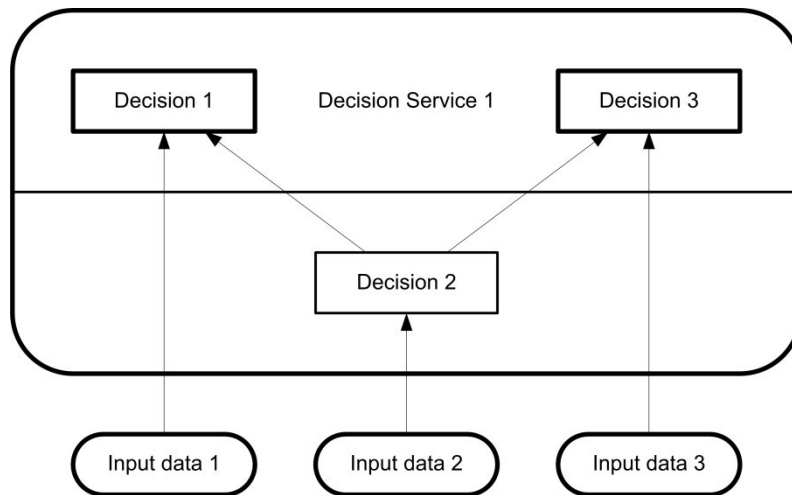

Figure 17: Decision Service notation

6.3 Metamodel

6.3.1 DMN Element metamodel

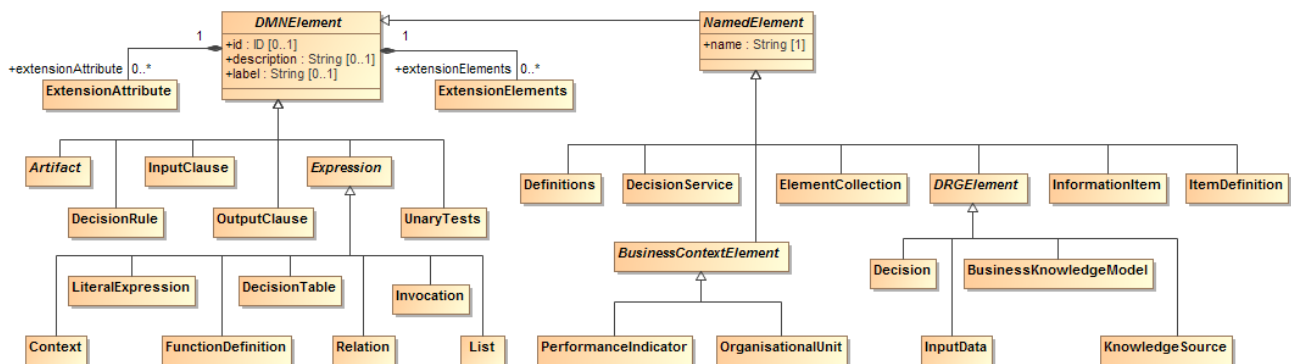

Figure 18: DMNElement Class Diagram

DMNElement is the abstract superclass for the decision model elements. It provides the optional attributes `id`, `description` and `label`, which are Strings which other elements will inherit. The `id` of a DMNElement is further restricted to the syntax of an XML ID (<http://www.w3.org/TR/2004/REC-xmlschema-2-20041028/datatypes.html#ID>), and SHALL be unique within the decision model.

DMNElement has abstract specializations `NamedElement` and `Expression`, and concrete specialization `UnaryTests`. `NamedElement` adds the required attribute `name`, and includes the abstract specializations `BusinessContextElement` and `DRGElement`, as well as concrete specializations `Definitions`, `ItemDefinition`, `InformationItem`, `ElementCollection` and `DecisionService`.

Table 3 presents the attributes and model associations of the DMNElement element.

Table 3: DMNElement attributes and model associations

Attribute	Description
id: ID [0..1]	Optional identifier for this element. SHALL be unique within its containing <code>Definitions</code> element.
description: String [0..1]	A description of this element.
label: String [0..1]	A label for this element
extensionElements: <code>ExtensionElement</code> [0..1]	This attribute is used as a container to attach additional elements to any DMN Element. See section 6.3.16 for additional information on extensibility.
extensionAttributes: <code>ExtensionAttribute</code> [0..*]	This attribute is used to attach named extended attributes and model associations. This association is not applicable when the XML schema interchange is used, since the XSD mechanism for supporting "anyAttribute" from other namespaces already satisfies this requirement. See section 6.3.16 for additional information on extensibility.

Table 4: NamedElement attributes and model associations

Attribute	Description
name: string	The name of this element.

6.3.2 Definitions metamodel

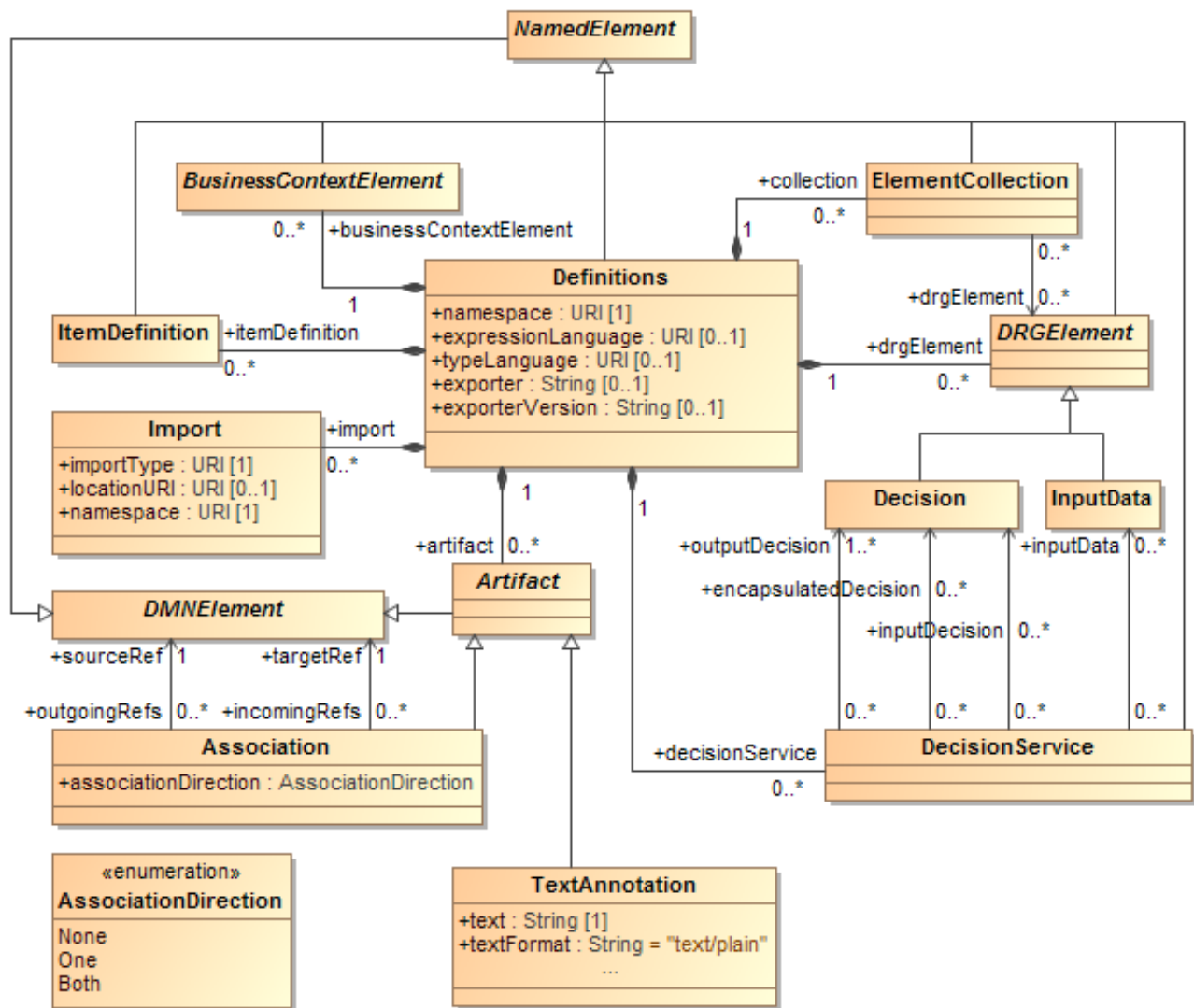

Figure 19: Definitions Class Diagram

The `Definitions` class is the outermost containing object for all elements of a **DMN** decision model. It defines the scope of visibility and the namespace for all contained elements. Elements that are contained in an instance of `Definitions` have their own defined life-cycle and are not deleted with the deletion of other elements. The interchange of **DMN** files will always be through one or more `Definitions`.

`Definitions` is a kind of `NamedElement`, from which an instance of `Definitions` inherits the name and optional id, description and label attributes, which are Strings.

An instance of `Definitions` has a `namespace`, which is a String. The `namespace` identifies the default target namespace for the elements in the `Definitions` and follows the convention established by XML Schema.

An instance of `Definitions` may specify an `expressionLanguage`, which is a URI that identifies the default expression language used in elements within the scope of this `Definitions`. This value may be overridden on each

individual `LiteralExpression`. The language SHALL be specified in a URI format. The default expression language is FEEL (clause 10), indicated by the URI: “<http://www.omg.org/spec/FEEL/20140401>”. The simple expression language S-FEEL (clause 9), being a subset of FEEL, is indicated by the same URI. **DMN** provides a URI for expression languages that are not meant to be interpreted automatically (e.g. pseudo-code that may resemble FEEL but is not): “<http://www.omg.org/spec/DMN/uninterpreted/20140801>”.

An instance of `Definitions` may specify a `typeLanguage`, which is a URI that identifies the default type language used in elements within the scope of this `Definitions`. For example, a `typeLanguage` value of “<http://www.w3.org/2001/XMLSchema>” indicates that the data structures defined within that `Definitions` are, by default, in the form of XML Schema types. If unspecified, the default `typeLanguage` is FEEL. This value may be overridden on each individual `ItemDefinition`. The `typeLanguage` SHALL be specified in a URI format (the URI for FEEL is “<http://www.omg.org/spec/FEEL/20140401>”; the URI “<http://www.omg.org/spec/DMN/uninterpreted/20140801>” can be used to indicate that a type definition is not meant to be interpreted)).

An instance of `Definitions` may specify an `exporter` and `exporterVersion`, which are Strings naming the tool and version used to create the XML serialization. In standards such as **BPMN**, this has been found to aid in model interchange between tools.

An instance of `Definitions` is composed of zero or more `drgElements`, which are instances of `DRGElement`, zero or more `collections`, which are instances of `ElementCollection`, zero or more `decisionServices`, which are instances of `DecisionService`, zero or more `itemDefinitions`, which are instances of `ItemDefinition` and of zero or more `businessContextElements`, which are instances of `BusinessContextElement`.

It may contain any number of associated `import`, which are instances of `Import`. Imports are used to import elements defined outside of this `Definitions`, e.g. in other `Definitions` elements, and to make them available for use by elements in this `Definitions`.

`Definitions` inherits all the attributes and model associations from `NamedElement`. Table 5 presents the additional attributes and model associations of the `Definitions` element.

Table 5: Definitions attributes and model associations

Attribute	Description
namespace: anyURI [1]	This attribute identifies the namespace associated with this <code>Definitions</code> and follows the convention established by XML Schema.
expressionLanguage: anyURI [0..1]	This attribute identifies the expression language used in <code>LiteralExpressions</code> within the scope of this <code>Definitions</code> . The Default is FEEL (clause 10). This value MAY be overridden on each individual <code>LiteralExpression</code> . The language SHALL be specified in a URI format.
typeLanguage: anyURI [0..1]	This attribute identifies the type language used in <code>LiteralExpressions</code> within the scope of this <code>Definitions</code> . The Default is FEEL (clause 10). This value MAY be overridden on each individual <code>ItemDefinition</code> . The language SHALL be specified in a URI format.

exporter: string [0..1]	This attribute names the tool used to export the XML serialization.
exporterVersion: string [0..1]	This attribute names the version of the tool used to export the XML serialization.
itemDefinition: ItemDefinition [*]	This attribute lists the instances of ItemDefinition that are contained in this Definitions.
drgelement: DRGElement [*]	This attribute lists the instances of DRGElement that are contained in this Definitions.
businessContextElement: BusinessContextElement [*]	This attribute lists the instances of BusinessContextElement that are contained in this Definitions.
collection: ElementCollection [*]	This attribute lists the instances of ElementCollection that are contained in this Definitions.
decisionService: DecisionService [*]	This attribute lists the instances of DecisionService that are contained in this Definitions.
import: Import [*]	This attribute is used to import externally defined elements and make them available for use by elements in this Definitions.
artifact: Artifact [0..*]	Artifacts include text annotations and associations among DMN elements.

6.3.3 Import metamodel

The `Import` class is used when referencing external elements, either **DMN** `DRGElement` instances contained in other `Definitions` elements, or non-**DMN** elements, such as an XML Schema or a PMML file. Imports SHALL be explicitly defined.

An instance of `Import` has an `importType`, which is a String that specifies the type of import associated with the element. For example, a value of “`http://www.w3.org/2001/XMLSchema`” indicates that the imported element is an XML schema. The **DMN** namespace indicates that the imported element is a **DMN** `Definitions` element.

The location of the imported element may be specified by associating an optional `locationURI` with an instance of `Import`. The `locationURI` is a URI.

An instance of `Import` has a `namespace`, which is a URI that identifies the namespace of the imported element.

Table 6 presents the attributes and model associations of the `Import` element.

Table 6: Import attributes and model associations

Attribute	Description
importType: anyURI	Specifies the style of import associated with this <code>Import</code> .

locationURI: anyURI [0..1]	Identifies the location of the imported element.
namespace: anyURI	Identifies the namespace of the imported element.

6.3.4 Element Collection metamodel

The `ElementCollection` class is used to define named groups of `DRGElement` instances. `ElementCollections` may be used for any purpose relevant to an implementation, for example:

- To identify the requirements subgraph of a set one or more decisions (i.e. all the elements in the closure of the requirements of the set)
- To identify the elements to be depicted on a DRD.

`ElementCollection` is a kind of `NamedElement`, from which an instance of `ElementCollection` inherits the name and optional `id`, `description` and `label` attributes, which are `Strings`. The `id` of an `ElementCollection` element SHALL be unique within the containing instance of `Definitions`.

An `ElementCollection` element has any number of associated `drgElements`, which are the instances of `DRGElement` that this `ElementCollection` defines together as a group. Notice that an `ElementCollection` element must reference the instances of `DRGElement` that it collects, not contain them: instances of `DRGElement` can only be contained in `Definitions` elements.

`ElementCollection` inherits all the attributes and model associations from `NamedElement`. Table 7 presents the additional attributes and model associations of the `ElementCollection` element.

Table 7: ElementCollection attributes and model associations

Attribute	Description
drgElement: <code>DRGElement</code> [*]	This attribute lists the instances of <code>DRGElement</code> that this <code>ElementCollection</code> groups.

6.3.5 DRG Element metamodel

`DRGElement` is the abstract superclass for all **DMN** elements that are contained within `Definitions` and that have a graphical representation in a DRD. All the elements of a **DMN** decision model that are not contained directly in a `Definitions` element (specifically: all three kinds of requirement, bindings, clause and decision rules, import, and objective) SHALL be contained in an instance of `DRGElement`, or in a model element that is contained in an instance of `DRGElement`, recursively.

The concrete specializations of `DRGElement` are `Decision`, `InputData`, `BusinessKnowledgeModel` and `KnowledgeSource`.

`DRGElement` is a specialization of `NamedElement`, from which it inherits the name and optional `id`, `description` and `label` attributes. The `id` of a `DRGElement` element SHALL be unique within the containing instance of `Definitions`.

A **Decision Requirements Diagram (DRD)** is the diagrammatic representation of one or more instances of `DRGElement` and their information, knowledge and authority requirement relations. The instances of `DRGElement` are represented as the vertices in the diagram; the edges represent instances of `InformationRequirement`, `KnowledgeRequirement` or `AuthorityRequirement` (see clauses 6.3.12, 6.3.13 and 6.3.14). The connection rules are specified in clause 6.2.3).

DRGELEMENT inherits all the attributes and model associations of NamedElement. It does not define additional attributes and model associations of the DRGELEMENT element.

6.3.6 Artifact metamodel

Artifacts are used to provide additional information about a Decision Model. DMN provides two standard Artifacts: Association and Text Annotation. Associations can be used to link Artifacts to any DMNELEMENT.

6.3.6.1 Association

An Association is used to link information and Artifacts with DMN graphical elements. Text Annotations and other Artifacts can be associated with the graphical elements. An arrowhead on the Association indicates a direction of flow (e.g., data), when appropriate.

The Association element inherits the attributes and model associations of DMNELEMENT (see Table 3). Table 8 presents the additional attributes and model associations for an Association.

Table 8: Association attributes and model associations:

Attribute	Description
associationDirection: AssociationDirection = None {None One Both}	associationDirection is an attribute that defines whether or not the Association shows any directionality with an arrowhead. The default is None (no arrowhead). A value of One means that the arrowhead SHALL be at the Target Object. A value of Both means that there SHALL be an arrowhead at both ends of the Association line.
sourceRef: DMNELEMENT[1]	The DMNELEMENT that the Association is connecting from.
targetRef: DMNELEMENT[1]	The DMNELEMENT that the Association is connecting to.

6.3.6.2 Text Annotation

Text Annotations are a mechanism for a modeler to provide additional text information for the reader of a DMN Diagram

The TextAnnotation element inherits the attributes and model associations of DMNELEMENT (see Table 3). Table 9 presents the additional attributes for a TextAnnotation.

Table 9: TextAnnotation attributes

Attribute	Description
text: string	Text is an attribute that is text that the modeler wishes to communicate to the reader of the Diagram.
textFormat: string = "text/plain"	This attribute identifies the format of the text. It SHALL

follow the mime-type format. The default is "text/plain."

6.3.7 Decision metamodel

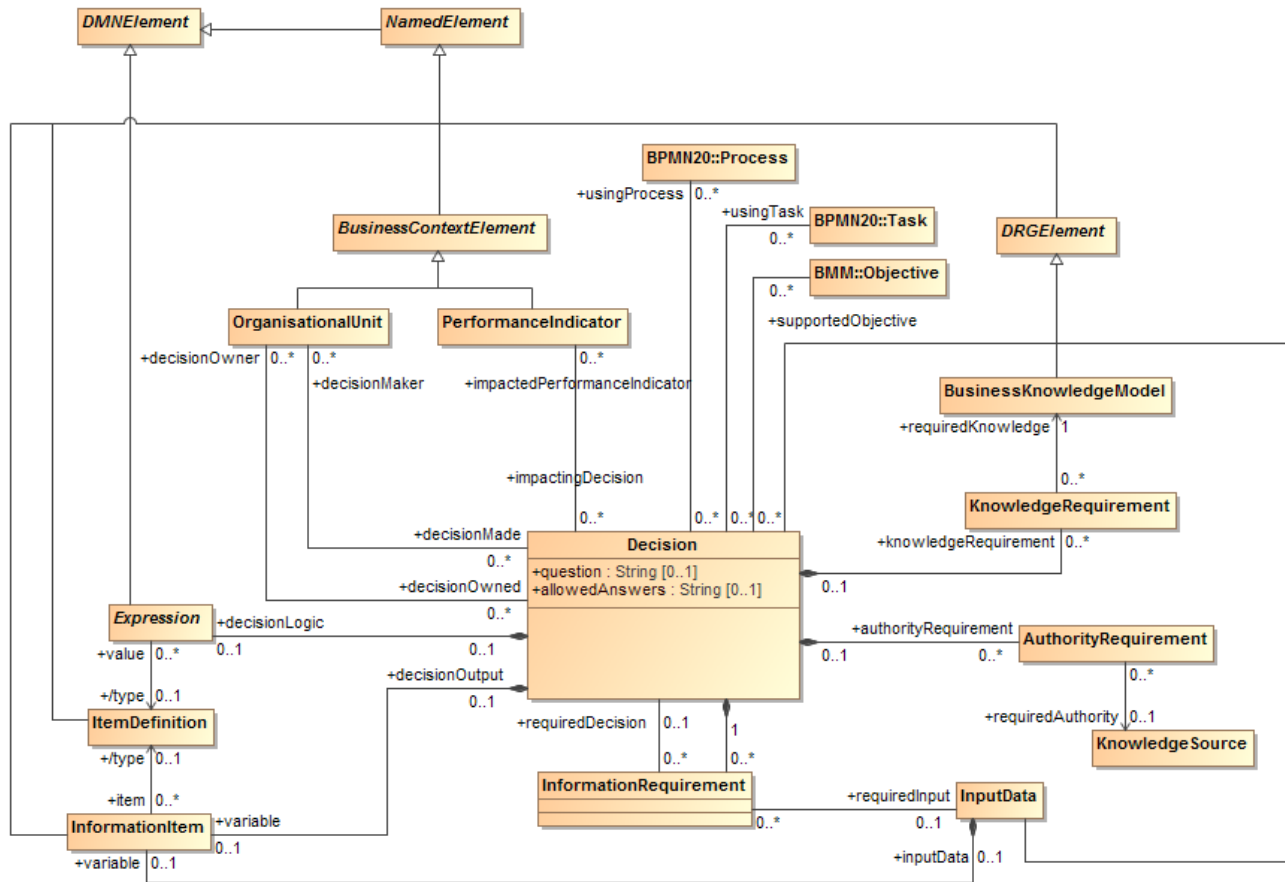

Figure 20: Decision Class Diagram

The class `Decision` is used to model a decision.

`Decision` is a concrete specialization of `DRGEElement` and it inherits the name and optional id, description and label attributes from `NamedElement`

In addition, it may have a `question` and `allowedAnswers`, which are all strings. The optional description attribute is meant to contain a brief description of the decision-making embodied in the `Decision`. The optional `question` attribute is meant to contain a natural language question that characterizes the `Decision` such that the output of the `Decision` is an answer to the question. The optional `allowedAnswers` attribute is meant to contain a natural language description of the answers allowed for the question such as Yes/No, a list of allowed values, a range of numeric values etc.

In a DRD, an instance of `Decision` is represented by a **decision** diagram element.

A Decision element is composed of an optional decisionLogic, which is an instance of Expression, and of zero or more informationRequirement, knowledgeRequirement and authorityRequirement elements, which are instances of InformationRequirement, KnowledgeRequirement and AuthorityRequirement, respectively.

In addition, a Decision defines an InformationItem representing its output. This InformationItem may include an optional typeRef, which references an ItemDefinition or other type definition specifying the datatype of the possible outcomes of the Decision.

The **requirement subgraph** of a Decision element is the directed graph composed of the Decision element itself, its informationRequirements, its knowledgeRequirements, and the union of the requirement subgraphs of each requiredDecision or requiredKnowledge element: that is, the requirement subgraph of a Decision element is the closure of the informationRequirement, requiredInput, requiredDecision, knowledgeRequirement and requiredKnowledge associations starting from that Decision element.

An instance of Decision – that is, the model of a decision – is said to be **well-formed** if and only if all of its informationRequirement and knowledgeRequirement elements are well-formed. That condition entails, in particular, that the requirement subgraph of a Decision element SHALL be acyclic, that is, that a Decision element SHALL not require itself, directly or indirectly.

Besides its logical components: information requirements, decision logic etc, the model of a decision may also document a business context for the decision (see clause 6.3.8 and Figure 21).

The business context for an instance of Decision is defined by its association with any number of supportedObjectives, which are instances of Objective as defined in OMG BMM, any number of impactedPerformanceIndicators, which are instances of PerformanceIndicator, any number of decisionMaker and any number of decisionOwner, which are instances of OrganisationalUnit.

In addition, an instance of Decision may reference any number of usingProcess, which are instances of Process as defined in OMG **BPMN 2.0**, and any number of usingTask, which are instances of Task as defined in OMG **BPMN 2.0**, and which are the Processes and Tasks that use the Decision element.

Decision inherits all the attributes and model associations from DRGElement. Table 10 presents the additional attributes and model associations of the Decision class.

Table 10: Decision attributes and model associations

Attribute	Description
question: string [0..1]	A natural language question that characterizes the Decision such that the output of the Decision is an answer to the question.
allowedAnswers: string [0..1]	A natural language description of the answers allowed for the question such as Yes/No, a list of allowed values, a range of numeric values etc.
variable: InformationItem	The instance of InformationItem that stores the result of this Decision.

typeRef: String[0..1]	A pointer to a specification of the datatype of the possible outcome values for this Decision, either an ItemDefinition, a base type in the specified expressionLanguage, or an imported type.
decisionLogic: Expression [0..1]	The instance of Expression that represents the decision logic for this Decision.
informationRequirement: InformationRequirement [*]	This attribute lists the instances of InformationRequirement that compose this Decision.
knowledgeRequirement: KnowledgeRequirement [*]	This attribute lists the instances of KnowledgeRequirement that compose this Decision.
authorityRequirement: AuthorityRequirement [*]	This attribute lists the instances of AuthorityRequirement that compose this Decision.
supportedObjective: BMM::Objective [*]	This attribute lists the instances of BMM::Objective that are supported by this Decision.
impactedPerformanceIndicator: PerformanceIndicator [*]	This attribute lists the instances of PerformanceIndicator that are impacted by this Decision.
decisionMaker: OrganisationalUnit [*]	The instances of OrganisationalUnit that make this Decision.
decisionOwner: OrganisationalUnit [*]	The instances of OrganisationalUnit that own this Decision.
usingProcesses: BPMN::process [*]	This attribute lists the instances of BPMN::process that require this Decision to be made.
usingTasks: BPMN::task [*]	This attribute lists the instances of BPMN::task that make this Decision.

6.3.8 Business Context Element metamodel

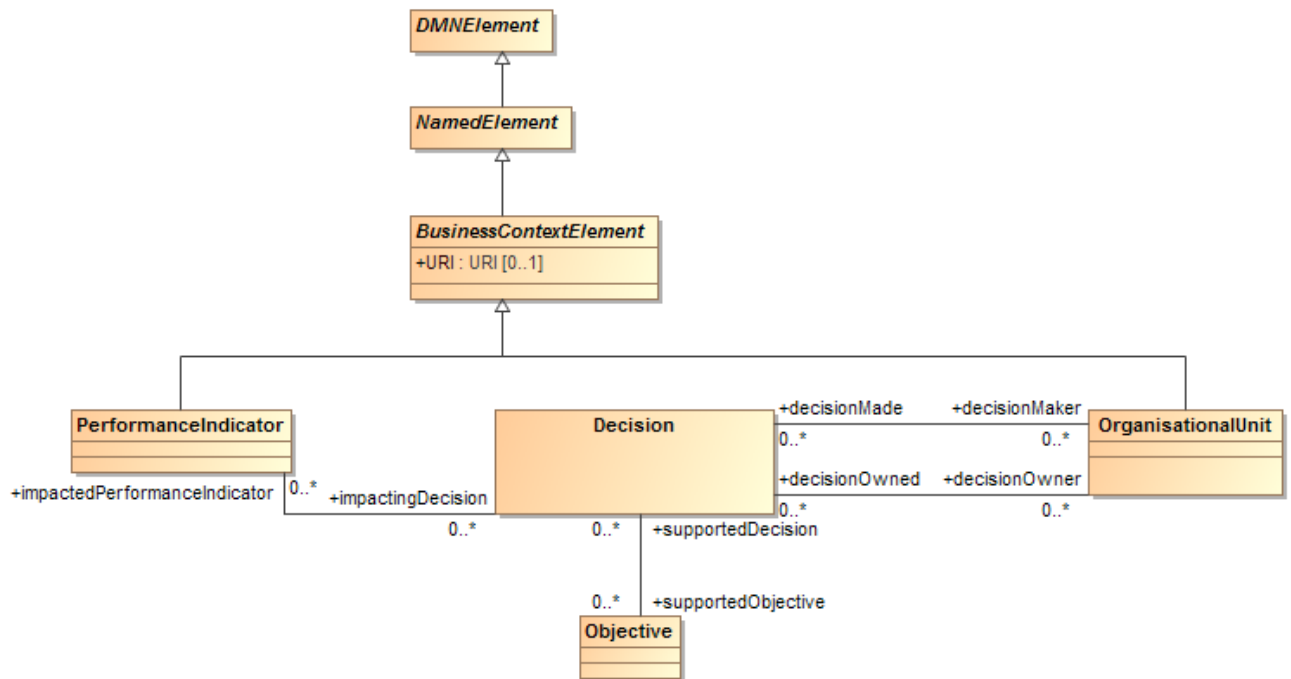

Figure 21: BusinessContextElement class diagram

The abstract class `BusinessContextElement`, and its concrete specializations `PerformanceIndicator` and `OrganizationUnit` are placeholders, anticipating a definition to be adopted from other OMG meta-models, such as OMG OSM when it is further developed.

`BusinessContextElement` is a specialization of `NamedElement`, from which it inherits the name and optional id, description and label attributes.

In addition, instances of `BusinessContextElements` may have a URI, which is a URI, and

- an instance of `PerformanceIndicator` references any number of `impactingDecision`, which are the `Decision` elements that impact it;
- an instance of `OrganisationalUnit` references any number of `decisionMade` and of `decisionOwned`, which are the `Decision` elements that model the decisions that the organization unit makes or owns.

`BusinessContextElement` inherits all the attributes and model associations from `NamedElement`. Table 11 presents the additional attributes and model associations of the `BusinessContextElement` class.

Table 11: BusinessContextElement attributes and model associations

Attribute	Description
URI: anyURI [0..1]	The URI of this <code>BusinessContextElement</code> .

PerformanceIndicator inherits all the attributes and model associations from BusinessContextElement. Table 12 presents the additional attributes and model associations of the PerformanceIndicator class.

Table 12: PerformanceIndicator attributes and model associations

Attribute	Description
impactingDecision: Decision [*]	This attribute lists the instances of Decision that impact this PerformanceIndicator.

OrganisationalUnit inherits all the attributes and model associations from BusinessContextElement. Table 13 presents the additional attributes and model associations of the OrganisationalUnit class.

Table 13: OrganisationalUnit attributes and model associations

Attribute	Description
decisionMade: Decision [*]	This attribute lists the instances of Decision that are made by this OrganisationalUnit.
decisionOwned: Decision [*]	This attribute lists the instances of Decision that are owned by this OrganisationalUnit.

6.3.9 Business Knowledge Model metamodel

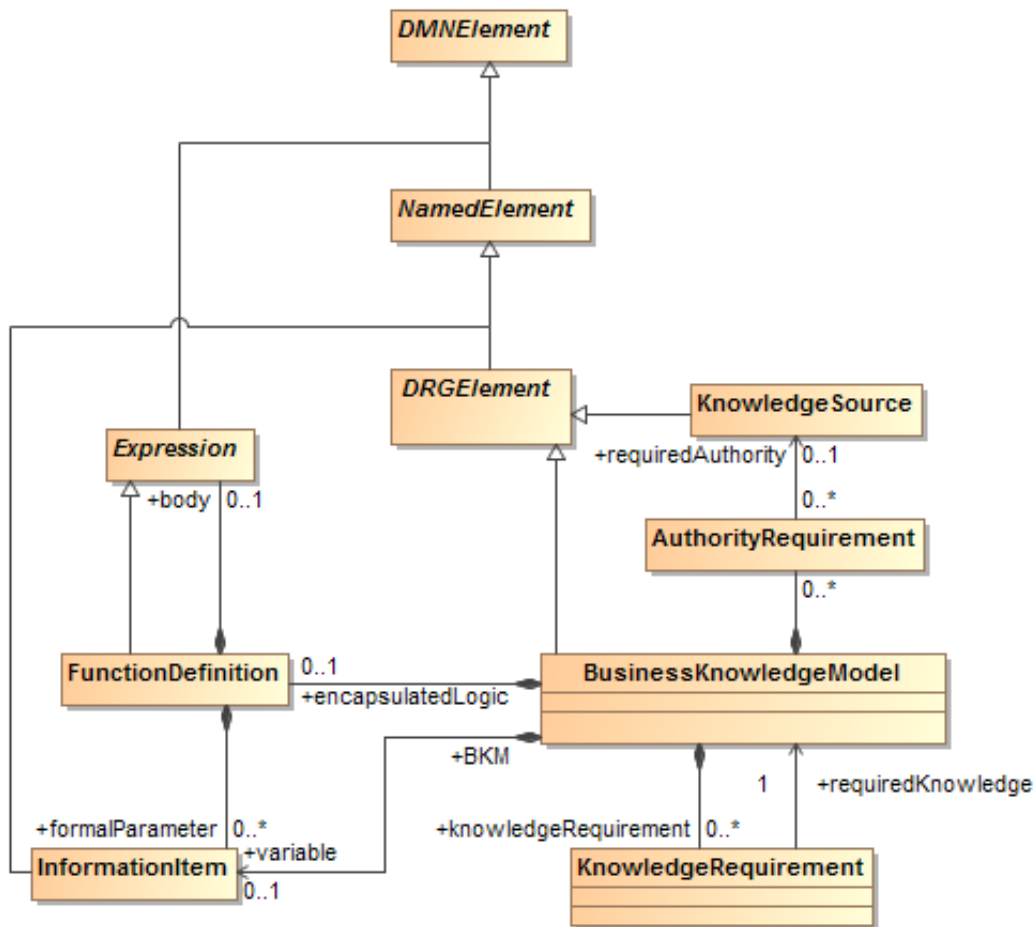

Figure 22: BusinessKnowledgeModel class diagram

The business knowledge models that are associated with a decision are reusable modular expressions of all or part of their decision logic.

The class BusinessKnowledgeModel is used to model a business knowledge model.

BusinessKnowledgeModel is a concrete specialization of DRGElement and it inherits the name and optional id, description and label attributes from NamedElement.

In a DRD, an instance of BusinessKnowledgeModel is represented by a **business knowledge model** diagram element.

A BusinessKnowledgeModel element may have zero or more knowledgeRequirement, which are instance of KnowledgeRequirement, and zero or more authorityRequirement, which are instances of AuthorityRequirement.

The **requirement subgraph** of a BusinessKnowledgeModel element is the directed graph composed of the BusinessKnowledgeModel element itself, its knowledgeRequirement elements, and the union of the

requirement subgraphs of all the `requiredKnowledge` elements that are referenced by its `knowledgeRequirements`.

An instance of `BusinessKnowledgeModel` is said to be **well-formed** if and only if, either it does not have any `knowledgeRequirement`, or all of its `knowledgeRequirement` elements are well-formed. That condition entails, in particular, that the requirement subgraph of a `BusinessKnowledgeModel` element SHALL be acyclic, that is, that a `BusinessKnowledgeModel` element SHALL not require itself, directly or indirectly.

At the decision logic level, a `BusinessKnowledgeModel` element contains a `FunctionDefinition`, which is an instance of `Expression` containing zero or more parameter, which are instances of `InformationItem`. The `FunctionDefinition` that is contained in a `BusinessKnowledgeModel` element is the reusable module of decision logic that is represented by this `BusinessKnowledgeModel` element. A `BusinessKnowledgeModel` element also contains an `InformationItem` that holds the `FunctionDefinition`, which allows a `Decision` to invoke it by name. The name of that `InformationItem` SHALL be the same as the name of the `BusinessKnowledgeModel` element. `BusinessKnowledgeModel` inherits all the attributes and model associations from `DRGElement`. Table 14 presents the additional attributes and model associations of the `BusinessKnowledgeModel` class.

Table 14: BusinessKnowledgeModel attributes and model associations

Attribute	Description
encapsulatedLogic: <code>FunctionDefinition</code> [0..1]	The function that encapsulates the logic encapsulated by this <code>BusinessKnowledgeModel</code> .
variable: <code>InformationItem</code>	The instance of <code>InformationItem</code> that is bound to the function. An invocation can reference this variable by name.
knowledgeRequirement: <code>KnowledgeRequirement</code> [*]	This attribute lists the instances of <code>KnowledgeRequirement</code> that compose this <code>BusinessKnowledgeModel</code> .
authorityRequirement: <code>AuthorityRequirement</code> [*]	This attribute lists the instances of <code>AuthorityRequirement</code> that compose this <code>BusinessKnowledgeModel</code> .
variable: <code>InformationItem</code>	This attribute defines a variable that holds the <code>FunctionDefinition</code> , allowing a <code>Decision</code> to invoke it by name.

6.3.10 Input Data metamodel

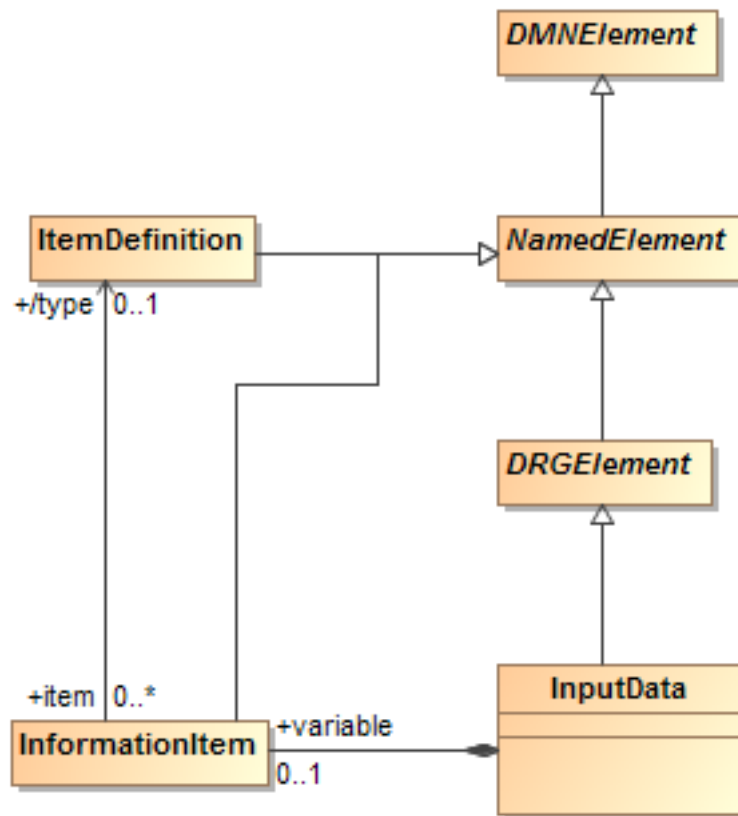

Figure 23: InputData class diagram

DMN 1.1 uses the class `InputData` to model the inputs of a decision whose values are defined outside of the decision model.

`InputData` is a concrete specialization of `DRGElement` and it inherits the name and optional id, description and label attributes from `NamedElement`.

An instance of `InputData` defines an `InformationItem` that stores its value. This `InformationItem` may include a `typeRef` that specifies the type of data that this `InputData` represents, either an `ItemDefinition`, base type in the specified `expressionLanguage`, or imported type.

In a DRD, an instance of `InputData` is represented by an **input data** diagram element. An `InputData` element does not have a **requirement subgraph**, and it is always **well-formed**.

`InputData` inherits all the attributes and model associations from `DRGElement`. Table 15 presents the additional attributes and model associations of the `InputData` class.

Table 15: InputData attributes and model associations

Attribute	Description
-----------	-------------

variable: InformationItem	The instance of InformationItem that stores the result of this InputData.
typeRef: String[0..1]	A pointer to a specification of the datatype of the possible values for this InputData, either an ItemDefinition, a base type in the specified expressionLanguage, or an imported type.

6.3.11 Knowledge Source metamodel

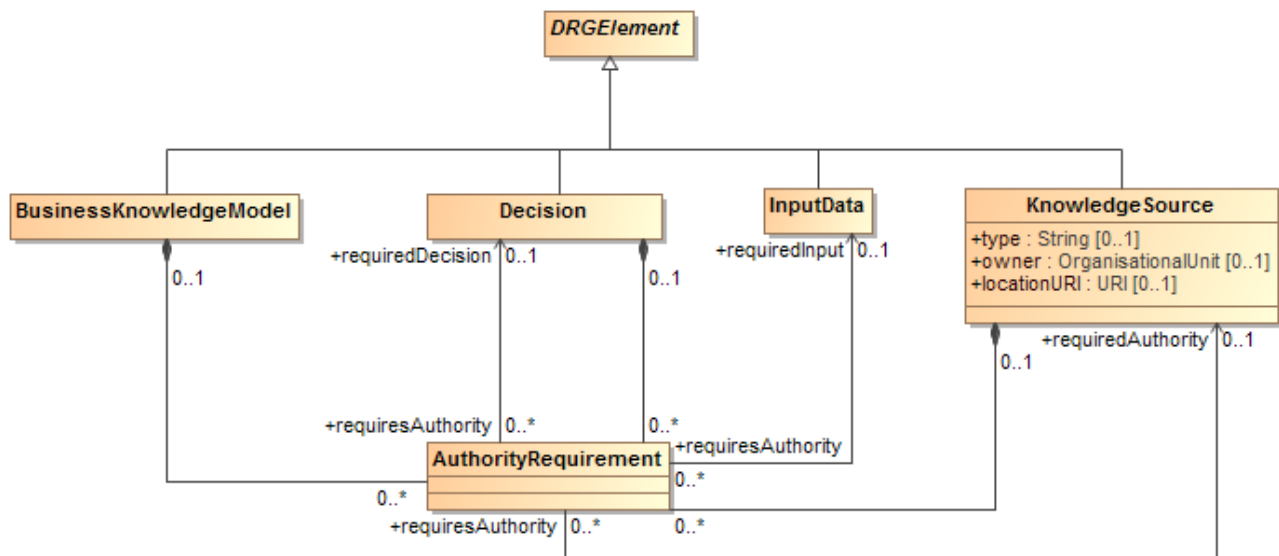

Figure 24: KnowledgeSource class diagram

The class KnowledgeSource is used to model authoritative knowledge sources in a decision model.

In a DRD, an instance of KnowledgeSource is represented by a **knowledge source** diagram element.

KnowledgeSource is a concrete specialization of DRGElement, and thus of NamedElement, from which it inherits the name and optional id, description and label attributes. In addition, a KnowledgeSource has a locationURI, which is a URI. It has a type, which is a string, and an owner, which is an instance of OrganisationalUnit. The type is intended to identify the kind of the authoritative source, e.g. Policy Document, Regulation, Analytic Insight.

A KnowledgeSource element is also composed of zero or more authorityRequirement elements, which are instances of AuthorityRequirement.

KnowledgeSource inherits all the attributes and model associations from DRGElement. Table 16 presents the attributes and model associations of the KnowledgeSource class.

Table 16: KnowledgeSource attributes and model associations

Attribute	Description
locationURI: anyURI [0..1]	The URI where this KnowledgeSource is located. The locationURI SHALL be specified in a URI format.
type: string [0..1]	The type of this KnowledgeSource.
owner: OrganisationalUnit [0..1]	The owner of this KnowledgeSource.
authorityRequirement: AuthorityRequirement [*]	This attribute lists the instances of AuthorityRequirement that contribute to this KnowledgeSource.

6.3.12 Information Requirement metamodel

The class InformationRequirement is used to model an **information requirement**, as represented by a plain arrow in a DRD.

An InformationRequirement element is a component of a Decision element, and it associates that requiring Decision element with a requiredDecision element, which is an instance of Decision, or a requiredInput element, which is an instance of InputData.

An InformationRequirement element references an instance of either a Decision or InputData, which defines a variable. That variable, which is an instance of InformationItem, represents the InformationRequirement element at the decision logic level.

Notice that an InformationRequirement element must reference the instance of Decision or InputData that it associates with the requiring Decision element, not contain it: instances of Decision or InputData can only be contained in Definitions elements.

An instance of InformationRequirement is said to be **well-formed** if and only if all of the following are true:

- it references a requiredDecision or a requiredInput element, but not both,
- the referenced requiredDecision or requiredInput element is well-formed,
- the Decision element that contains the instance of InformationRequirement is not in the requirement subgraph of the referenced requiredDecision element, if this InformationRequirement element references one.

Table 17 presents the attributes and model associations of the InformationRequirement element.

Table 17: InformationRequirement attributes and model associations

Attribute	Description
requiredDecision: Decision [0..1]	The instance of Decision that this InformationRequirement associates with its containing Decision element.

requiredInput: InputData [0..1]	The instance of InputData that this InformationRequirement associates with its containing Decision element.
--	---

6.3.13 Knowledge Requirement metamodel

The class KnowledgeRequirement is used to model a **knowledge requirement**, as represented by a dashed arrow in a DRD.

A KnowledgeRequirement element is a component of a Decision element or of a BusinessKnowledgeModel element, and it associates that requiring Decision or BusinessKnowledgeModel element with a requiredKnowledge element, which is an instance of BusinessKnowledgeModel.

Notice that a KnowledgeRequirement element must reference the instance of BusinessKnowledgeModel that it associates with the requiring Decision or BusinessKnowledgeModel element, not contain it: instances of BusinessKnowledgeModel can only be contained in Definitions elements.

An instance of KnowledgeRequirement is said to be **well-formed** if and only if all of the following are true:

- it references a requiredKnowledge element,
- the referenced requiredKnowledge element is well-formed,
- if the KnowledgeRequirement element is contained in an instance of BusinessKnowledgeModel, that BusinessKnowledgeModel element is not in the requirement subgraph of the referenced requiredKnowledge element.

Table 18 presents the attributes and model associations of the KnowledgeRequirement element.

Table 18: KnowledgeRequirement attributes and model associations

Attribute	Description
requiredKnowledge: BusinessKnowledgeModel	The instance of BusinessKnowledgeModel that this KnowledgeRequirement associates with its containing Decision or BusinessKnowledgeModel element.

6.3.14 Authority Requirement metamodel

The class AuthorityRequirement is used to model an **authority requirement**, as represented by an arrow drawn with a dashed line and a filled circular head in a DRD.

An AuthorityRequirement element is a component of a Decision, BusinessKnowledgeModel or KnowledgeSource element, and it associates that requiring Decision, BusinessKnowledgeModel or KnowledgeSource element with a requiredAuthority element, which is an instance of KnowledgeSource, a requiredDecision element, which is an instance of Decision, or a requiredInput element, which is an instance of InputData.

Notice that an AuthorityRequirement element must reference the instance of KnowledgeSource, Decision or InputData that it associates with the requiring element, not contain it: instances of KnowledgeSource, Decision or InputData can only be contained in Definitions elements.

Table 19 presents the attributes and model associations of the AuthorityRequirement element.

Table 19: AuthorityRequirement attributes and model associations

Attribute	Description
requiredAuthority: KnowledgeSource [0..1]	The instance of KnowledgeSource that this AuthorityRequirement associates with its containing KnowledgeSource, Decision or BusinessKnowledgeModel element.
requiredDecision: Decision [0..1]	The instance of Decision that this AuthorityRequirement associates with its containing KnowledgeSource element.
requiredInput: InputData [0..1]	The instance of InputData that this AuthorityRequirement associates with its containing KnowledgeSource element.

6.3.15 Decision service metamodel

The DecisionService class is used to define named decision services against the decision model contained in an instance of Definitions.

DecisionService is a kind of NamedElement, from which an instance of DecisionService inherits the name and optional id, description and label attributes, which are Strings. The id of a DecisionService element SHALL be unique within the containing instance of Definitions.

A DecisionService element has one or more associated outputDecisions, which are the instances of Decision required to be output by this DecisionService, i.e. the Decisions whose results the Decision Service must return when called.

A DecisionService element has zero or more encapsulatedDecisions, which are the instances of Decision required to be encapsulated by this DecisionService, i.e. the Decisions to be evaluated by the Decision Service when it is called.

A DecisionService element has zero or more inputDecisions, which are the instances of Decision required as input by this DecisionService, i.e. the Decisions whose results will be provided to the Decision Service when it is called.

A DecisionService element has zero or more inputData, which are the instances of InputData required as input by this DecisionService, i.e. the Input Data which will be provided to the Decision Service when it is called.

The encapsulatedDecisions, inputDecisions and inputData attributes are optional. At least one of the encapsulatedDecisions and inputDecisions attributes SHALL be specified.

DecisionService inherits all the attributes and model associations from NamedElement. **Table 20** presents the additional attributes and model associations of the DecisionService element.

Table 20: DecisionService attributes and model associations

Attribute	Description
outputDecisions: Decision [1..*]	This attribute lists the instances of Decision required to be output by this DecisionService.
encapsulatedDecisions: Decision [0..*]	If present, this attribute lists the instances of Decision to be encapsulated in this DecisionService
inputDecisions: Decision [0..*]	If present, this attribute lists the instances of Decision required as input by this DecisionService.
inputData: InputData [0..*]	If present, this attribute lists the instances of InputData required as input by this service

6.3.16 Extensibility

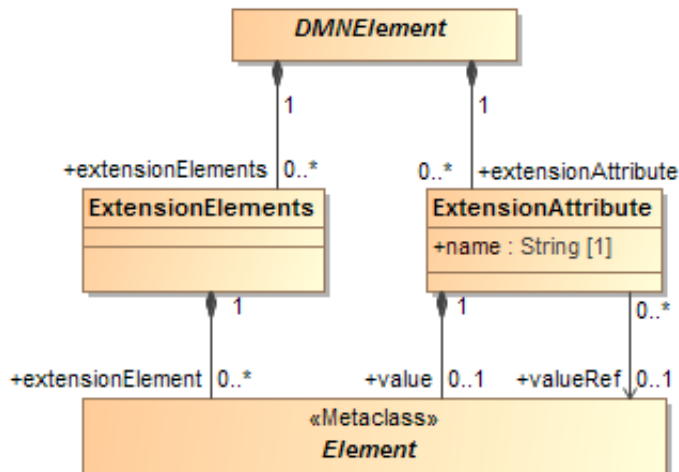

Figure 25: Extensibility class diagram

The **DMN** metamodel is aimed to be extensible. This allows **DMN** adopters to extend the specified metamodel in a way that allows them to be still **DMN**-compliant. It provides a set of extension elements, which allows **DMN** adopters to attach additional attributes and elements to standard and existing **DMN** elements. This approach results in more interchangeable models, because the standard elements are still intact and can still be understood by other **DMN** adopters. It's only the additional attributes and elements that **MAY** be lost during interchange.

A **DMN** extension can be done using two different elements:

1. ExtensionElements
2. ExtensionAttribute

`ExtensionElements` is a container for attaching arbitrary elements from other metamodels to any **DMN** element. `ExtensionAttribute` allows these attachments to also have name. This allows **DMN** adopters to integrate any metamodel into the **DMN** metamodel and reuse already existing model elements.

6.3.16.1 ExtensionElements

The `ExtensionElements` element is a container to aggregate elements from other metamodels inside any `DMNElement`. Table 21 presents the attributes and model associations for the `ExtensionElements` element.

Table 21: ExtensionElements attributes and model associations

Attribute	Description
extensionElement: Element [0..*]	The contained Element. This association is not applicable when the XML schema interchange is used, since the XSD mechanism for supporting "any" elements from other namespaces already satisfies this requirement.

6.3.16.2 ExtensionAttribute

The `ExtensionAttribute` element contains an Element or a reference to an Element from another metamodel. An `ExtensionAttribute` also has a name to define the role or purpose of the associated element. This type is not applicable when the XML schema interchange is used, since the XSD mechanism for supporting "anyAttribute" from other namespaces already satisfies this requirement. Table 22 presents the model associations for the `ExtensionAttribute` element.

Table 22: ExtensionAttribute attributes and model associations

Attribute	Description
name: string	The name of the extension attribute.
value: Element [0..1]	The contained Element. This attribute SHALL NOT be used together with <code>valueRef</code> .
valueRef: Element [0..1]	A reference to the associated Element. This attribute SHALL NOT be used together with <code>value</code> .

6.4 Examples

Examples of DRDs are provided in clause 11.2.

7 Relating Decision Logic to Decision Requirements

7.1 Introduction

Clause 6 described how the decision requirements level of a decision model – a DRG represented in one or more DRDs – may be used to model the structure of an area of decision making. However, the details of how each decision's outcome is derived from its inputs must be modeled at the decision logic level. This section introduces the principles by which decision logic may be associated with elements in the DRG. Specific representations of decision logic (decision tables and FEEL expressions) are then defined in clauses 8, 9 and 10.

The decision logic level of a decision model in **DMN** consists of one or more value expressions. The elements of decision logic modeled as value expressions include tabular expressions such as decision tables and invocations, and literal (text) expressions such as *age > 30*.

- A **literal expression** represents decision logic as text that describes how an output value is derived from its input values. The expression language may, but need not, be formal or executable: examples of literal expressions include a plain English description of the logic of a decision, a first order logic proposition, a Java computer program and a PMML document. Clause 10 specifies an executable expression language called **FEEL**. Clause 9 specifies a subset of FEEL (S-FEEL) that is the default language for literal expressions in **DMN** decision tables (clause 8).
- A **decision table** is a tabular representation of decision logic, based on a discretization of the possible values of the inputs of a decision, and organized into rules that map discretized input values onto discrete output values (see clause 8).
- An **invocation** is a tabular representation of how decision logic that is represented by a business knowledge model is invoked by a decision, or by another business knowledge model. An invocation may also be represented as a literal expression, but usually the tabular representation will be more understandable.

Tabular representations of decision logic are called *boxed expressions* in the remainder of this specification.

All three **DMN** conformance levels include all the above expressions. At **DMN** Conformance Level 1, literal expressions are not interpreted and, therefore, free. At **DMN** Conformance Level 2, literal expressions are restricted to S-FEEL. Clause 10 specifies additional boxed expressions available at **DMN** Conformance Level 3.

Decision logic is added to a decision model by including a value expression component in some of the decision model elements in the DRG:

- From a decision logic viewpoint, a decision is a piece of logic that defines how a given question is answered, based on the input data. As a consequence, each **decision** element in a decision model may include a value expression that describes how a decision outcome is derived from its required input, possibly invoking a business knowledge model;
- From a decision logic viewpoint, a business knowledge model is a piece of decision logic that is defined as a function allowing it to be re-used in multiple decisions. As a consequence, each **business knowledge model** element may include a value expression, which is the body of that function.

Another key component of the decision logic level is the **variable**: Variables are used to store values of Decisions and InputData for use in value expressions. InformationRequirements specify variables in scope via reference to those Decisions and InputData, so that value expressions may reference these variables. Variables link information requirements in the DRG to the value expressions at the decision logic level:

- From a decision logic viewpoint, an information requirement is a requirement for an externally provided value to be assigned to a free variable in the decision logic, so that a decision can be evaluated. As a consequence, each **information requirement** in a decision model points to a Decision or InputData, which in turn defines a variable that represents the associated data input in the decision's expression.

- The variables that are used in the body of the function defined by a business knowledge model element in the DRG must be bound to the information sources in each of the requiring decisions. As a consequence, each **business knowledge model** includes zero or more variables that are the parameters of the function.

The third key element of the decision logic level are the **item definitions** that describe the types and structures of data items in a decision model: **input data** elements in the DRG, and **variables** and **value expressions** at the decision logic level, may reference an associated item definition that describes the type and structure of the data expected as input, assigned to the variable or resulting from the evaluation of the expression.

Notice that **knowledge sources** are not represented at the decision logic level: knowledge sources are part of the documentation of the decision logic, not of the decision logic itself.

The dependencies between decisions, required information sources and business knowledge models, as represented by the information and knowledge requirements in a DRG, constrain how the value expressions associated with these elements relate to each other.

As explained above, every information requirement at the DRG level is associated with a variable used at the decision logic level. Each variable that is referenced by a decision's expression must be a variable referenced by one of the decision's information requirements or an information requirement in the decision's requirement subgraph. Also, each variable in a decision's information requirement must be a variable referenced in the decision's expression.

- If a decision requires another decision, the value expression of the required decision assigns the value to the variable for use in evaluating the requiring decision. This is the generic mechanism in **DMN** for composing decisions at the decision logic level.
- If a decision requires an input data, the value of the variable is assigned the value of the data source attached to the input data at execution time. This is the generic mechanism in **DMN** for instantiating the data requirements for a decision. Notice that, for required input data, FEEL allows test data to be specified for input data.

The input variables of a decision's decision logic must not be used outside that value expression or its component value expressions: the decision element defines the lexical scope of the input variables for its decision logic. To avoid name collisions and ambiguity, the name of a variable must be unique within its scope. When DRG elements are mapped to FEEL, the name of a variable is the same as the (possibly qualified) name of its associated input data or decision, which guarantees its uniqueness.

When DRG elements are mapped to FEEL, all the decisions and input data in a DRG define a *context*, which is the literal expression that represents the logic associated with the decision element and that represents that scope (see 9.3.2.8). The information requirement elements in a decision are *context entries* in the associated context, where the *key* is the name of the variable that the information requirement defines, and where the *expression* is the *context* that is associated with the required decision or input data element that the information requirement references. The value expression that is associated with the decision as its decision logic is the *expression* in the *context entry* that specifies what is the result of the *context*.

In the same way, a business knowledge model element defines the lexical scope of its parameters, that is, of the input variables for its body.

In FEEL, the literal expression and scoping construct that represents the logic associated with a business knowledge model element is a *function definition* (see 10.3.2.11), where the *formal parameters* are the names of the parameters in the business knowledge model element, and the *expression* is the value expression that is the body of the business knowledge model element.

If a business knowledge model element requires one or more other business knowledge models, it must have an explicit value expression that describes how the required business knowledge models are invoked and their results combined or otherwise elaborated.

At the decision logic level, a decision invokes a required business knowledge model by evaluating the business knowledge model's value expression with the parameters bound to its own input value. How this may be achieved depends on how the decision logic is partitioned between the decision and business knowledge models:

- If a decision element requires more than one business knowledge element, its value expression must be a literal expression that specifies how the business knowledge model elements are invoked and how their results are combined into the decision's outcome.

- If a decision does not require any business knowledge models, its value expression must be a literal expression or decision table that specifies the entire decision logic for deriving the output from the inputs.
- Similarly, if a decision element requires only one business knowledge model element, but the logic of the decision elaborates on the logic of its required business knowledge model, the decision element must have a literal expression that specifies how the business knowledge model's value expression is invoked, and how its result is elaborated to provide the decision's outcome.
- In all other cases (i.e. when a decision requires exactly one business knowledge model and does not elaborate the logic), the value expression of a decision element may be a value expression of type invocation. In a value expression of type invocation, only the bindings of the business knowledge model parameters to the decisions input data need be specified: the outcome of the decision is the result returned by the business knowledge model's value expression for the values passed to its parameters.

The binding of a business knowledge model's parameter is a value expression that specifies how the value passed to that parameter is derived from the values of the input variables of the invoking decision.

7.2 Notation

7.2.1 Boxed Expressions

We define a graphical notation for decision logic called **boxed expressions**. This notation serves to decompose the decision logic model into small pieces that can be associated with DRG artifacts. The DRD plus the boxed expressions form a complete, mostly graphical language that completely specifies Decision Models.

In addition to the generic notion of **boxed expression**, this section specifies two kinds of boxed expressions:

- **boxed literal expression**,
- **boxed invocation**.

The boxed expression for a decision table is defined in clause 8. Further types of boxed expressions are defined for FEEL, in clause 10.

Boxed expressions are defined recursively, *i.e.* boxed expressions can contain other boxed expressions. The top-level boxed expression corresponds to the decision logic of a single DRG artifact. This boxed expression SHALL have a name box that contains the name of the DRG artifact. The name box may be attached in a single box on top, as shown in Figure 26:

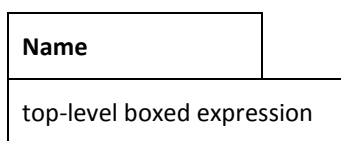

Figure 26: Boxed expression

Alternatively, the name box and expression box can be separated by white space and connected on the left side with a line, as shown in Figure 27:

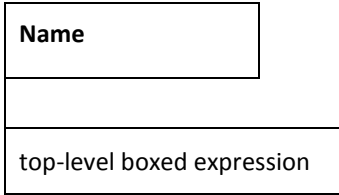

Figure 27: Boxed expression with separated name and expression boxes

Name is the only visual link defined between DRD elements and boxed expressions. Graphical tools are expected to support appropriate graphical links, for example, clicking on a decision shape opens a decision table. How the boxed expression is visually associated with the DRD element is left to the implementation.

7.2.2 Boxed literal expression

In a boxed expression, a literal expression is represented by its text. However, two notational conventions are provided to improve the readability of boxed literal expressions: typographical string literals and typographical date and time literals.

7.2.2.1 Typographical string literals

A string literal such as "DECLINED" can be represented alternatively as the italicized literal *DECLINED*. For example, Figure 28 is equivalent to Figure 29:

Credit contingency factor table		
U	Risk Category	Credit Contingency Factor
1	<i>HIGH, DECLINE</i>	0.6
2	<i>MEDIUM</i>	0.7
3	<i>LOW, VERY LOW</i>	0.8

Figure 28: Decision table with italicized literals

Credit contingency factor table		
U	Risk Category	Credit Contingency Factor
1	"HIGH", "DECLINE"	0.6
2	"MEDIUM"	0.7
3	"LOW", "VERY LOW"	0.8

Figure 29: Decision table with string literals

To avoid having to discern whether (e.g.) *HIGH, DECLINE* is "HIGH", "DECLINE" or "HIGH, DECLINE", typographical string literals SHALL be free of commas ("," characters). FEEL typographical string literals SHALL conform to grammar rule 27 (name).

7.2.2.2 Typographical date and time literals

A date, time, date and time, or duration expression such as `date("2013-08-09")` can be represented alternatively as the bold italicized literal ***2013-08-09***. The literal SHALL obey the syntax specified in clauses 10.3.2.3.4, 10.3.2.3.5 and 10.3.2.3.7.

7.2.3 Boxed invocation

An invocation is a container for the parameter bindings that provide the context for the evaluation of the body of a business knowledge model.

The representation of an invocation is the name of the business knowledge model with the parameters' bindings explicitly listed.

As a boxed expression, an invocation is represented by a box containing the name of the business knowledge model to be invoked, and boxes for a list of bindings, where each binding is represented by two boxed expressions on a row: the box on the left contains the name of a parameter, and the box on the right contains the binding expression, that is the expression whose value is assigned to the parameter for the purpose of evaluating the invoked business knowledge model (see Figure 30).

Name	
invoked business knowledge model	
parameter 1	Binding expression 1
...	
parameter 2	Binding expression 2
parameter <i>n</i>	Binding expression <i>n</i>

Figure 30: Boxed invocation

The invoked business knowledge model is represented by the name of the business knowledge model. Any other visual linkage is left to the implementation.

7.3 Metamodel

An important characteristic of decisions and business knowledge models is that they may contain an expression that describes the logic by which a modeled decision shall be made, or pieces of that logic.

The class `Expression` is the abstract superclass for all expressions that are used to describe complete or parts of decision logic in **DMN** models and that return a single value when interpreted (clause 7.3.1). Here “single value” possibly includes structured data, such as a decision table with multiple output clauses.

DMN defines three concrete kinds of `Expression`: `LiteralExpression`, `DecisionTable` (see clause 8) and `Invocation`.

An expression may reference variables, such that the value of the expression, when interpreted, depends on the values assigned to the referenced variables. The class `InformationItem` is used to model variables in expressions.

The value of an expression, like the value assigned to a variable, may have a structure and a range of allowable values. The class `ItemDefinition` is used to model data structures and ranges.

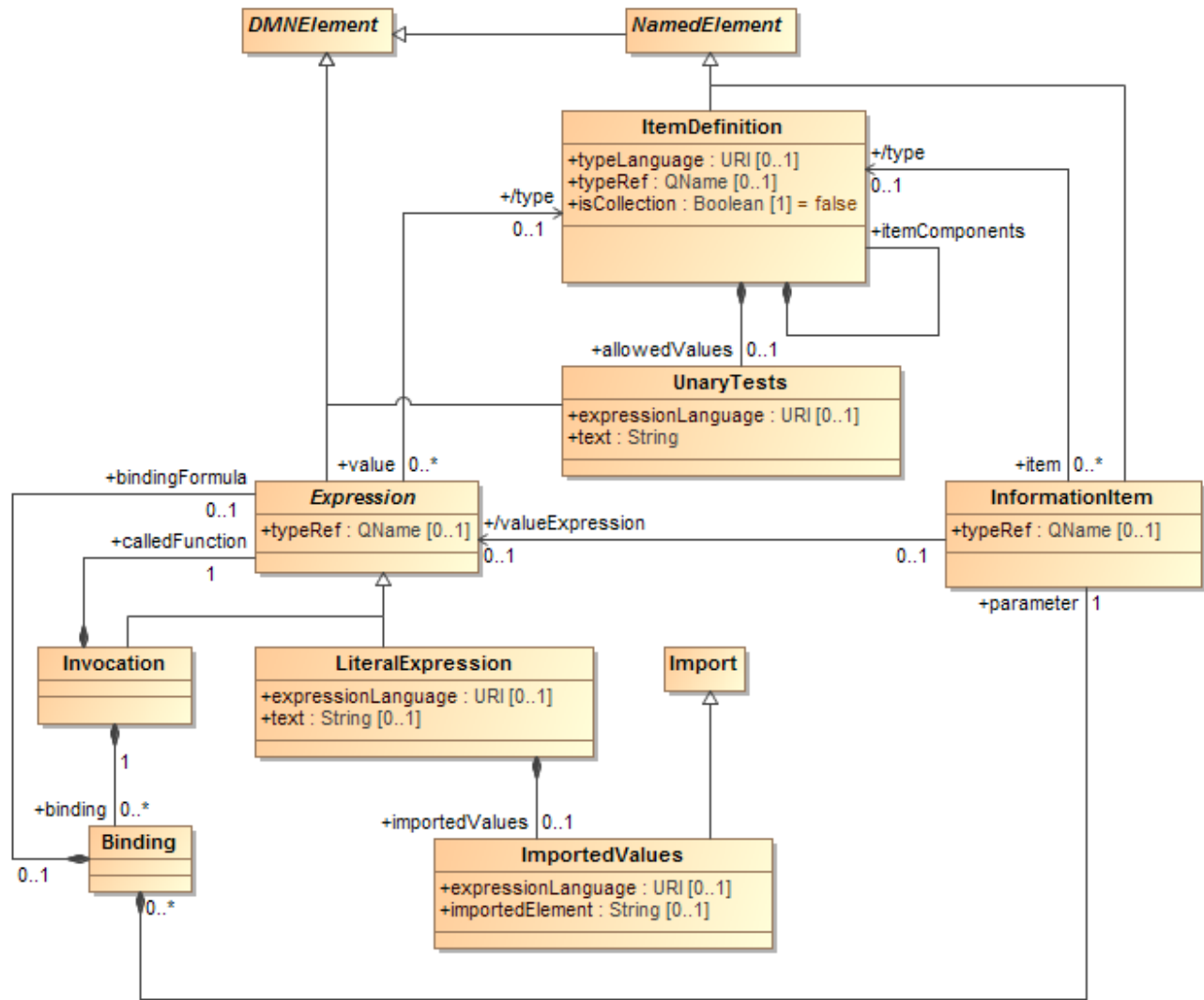

Figure 31: Expression class diagram

7.3.1 Expression metamodel

An important characteristic of decisions and business knowledge models, is that they may contain an expression that describes the logic by which a modeled decision shall be made, or pieces of that logic.

Expression is an abstract specialization of `DMNElement`, from which it inherits the name, and optional `id`, `description` and `label` attributes.

An instance of `Expression` is a component of a `Decision` element, of a `BusinessKnowledgeModel` element, or of an `ItemDefinition` element, or it is a component of another instance of `Expression`, directly or indirectly.

An `Expression` references zero or more variables implicitly by using their names in its expression text. These variables, which are instances of `InformationItem`, are lexically scoped, depending on the `Expression` type. If the `Expression` is the logic of a `Decision`, the scope includes that `Decision`'s requirements. If the `Expression` is the body of the `encapsulatedLogic` of a `BusinessKnowledgeModel`, the scope includes the `FunctionDefinition`'s parameters and the `BusinessKnowledgeModel`'s requirements. If the `Expression` is the value of a `ContextEntry`, the scope includes the previous entries in the `Context`. An instance of `Expression` references an optional `typeRef`, which points to either a base type in the default `typeLanguage`, a custom type specified by an `ItemDefinition`, or an imported type. The referenced type specifies the `Expression`'s range of possible values. If an instance of `Expression` that defines the output of a `Decision` element includes a `typeRef`, the referenced type SHALL be the same as the type of the containing `Decision` element.

An instance of `Expression` can be interpreted to derive a single value from the values assigned to its variables. How the value of an `Expression` element is derived from the values assigned to its variables depends on the concrete kind of the `Expression`.

`Expression` inherits from the attributes and model associations of `DMNElement`.

7.3.2 ItemDefinition metamodel

The inputs and output of decisions are data items whose value, at the decision logic level, is assigned to variables or represented by value expressions.

An important characteristic of data items in decision models is their structure. **DMN** does not require a particular format for this data structure, but it does designate a subset of FEEL as its default.

The class `ItemDefinition` is used to model the structure and the range of values of the input and the outcome of decisions.

As a concrete specialization of `NamedElement`, an instance of `ItemDefinition` has a name and an optional `id` and `description`. The name of an `ItemDefinition` element SHALL be unique within the containing instance of `Definitions` and its associated namespace.

The default type language for all elements can be specified in the `Definitions` element using the `typeLanguage` attribute. For example, a `typeLanguage` value of `http://www.w3.org/2001/XMLSchema` indicates that the data structures used by elements within that `Definitions` are in the form of XML Schema types. If unspecified, the default is FEEL.

Notice that the data types that are built-in in the `typeLanguage` that is associated with an instance of `Definitions` need not be redefined by `ItemDefinition` elements contained in that `Definitions` element: they are considered imported and can be referenced in **DMN** elements within the `Definitions` element.

The type language can be overridden locally using the `typeLanguage` attribute in the `ItemDefinition` element.

Notice, also, that the data types and structures that are defined at the top level in a data model that is imported using an `Import` element that is associated with an instance of `Definitions` need not be redefined by `ItemDefinition` elements contained in that `Definitions` element: they are considered imported and can be referenced in **DMN** elements within the `Definitions` element.

An `ItemDefinition` element SHALL have a `typeRef`, which is a `QName` that references, by namespace prefix and local name, either an `ItemDefinition` in the current instance of `Definitions` or a built-in type in the specified `typeLanguage` or a type defined in an imported DMN, XSD, or other document. In the latter case, the external document SHALL be imported in the `Definitions` element that contains the instance of `ItemDefinition`, using an `Import` element. For example, in the case of data structures contributed by an XML schema, an `Import` would be used to specify the file location of that schema, and the `typeRef` attribute would reference the type or element definition in the imported schema. If the type language is FEEL the built-in types are the FEEL built-in data types: *number*, *string*, *boolean*, *days* and *time duration*, *years* and *months duration*, *time* and *date and time*.

An `ItemDefinition` element may restrict the values that are allowed from `typeRef`, using the `allowedValues` attribute. The `allowedValues` are an instance of `UnaryTests` that specifies the allowed values or ranges of allowed values within the domain of the `typeRef`. The type of the allowed values SHALL be consistent with the containing `ItemDefinition` element. If an `ItemDefinition` element contains one or more `allowedValues`, the `allowedValues` specifies the complete range of values that this `ItemDefinition` represents. If an `ItemDefinition` element does not contain `allowedValues`, its range of allowed values is the full range of the referenced `typeRef`. In cases where the values that an `ItemDefinition` element represents are collections of values in the allowed range, the multiplicity can be projected into the attribute `isCollection`. The default value for this attribute is *false*.

An alternative way to define an instance of `ItemDefinition` is as a composition of `ItemDefinition` elements. An instance of `ItemDefinition` may contain zero or more `itemComponent`, which are themselves `ItemDefinitions`. Each `itemComponent` in turn may be defined by either a `typeRef` and `allowedValues` or a nested `itemComponent`. In this way, complex types may be defined within DMN. The name of an `itemComponent` (nested `ItemDefinition`) must be unique within its containing `ItemDefinition`. An `ItemDefinition` element SHALL be defined using only one of the alternative ways:

- reference to a built-in or imported `typeRef`, possibly restricted with `allowedValues`;
- composition of `ItemDefinition` elements.

The `ItemDefinition` element specializes `NamedElement` and it inherits its attributes and model associations. Table 23 presents the additional attributes and model associations of the `ItemDefinition` element.

Table 23: `ItemDefinition` attributes and model associations

Attribute	Description
typeRef: String [1]	This attribute identifies by namespace-prefixed name the base type of this <code>ItemDefinition</code>
typeLanguage: String [0..1]	This attribute identifies the type language used to specify the base type of this <code>ItemDefinition</code> . This value overrides the type language specified in the <code>Definitions</code> element. The language SHALL be specified in a URI format.
allowedValues: <code>UnaryTests</code> [0..1]	This attribute lists the possible values or ranges of values in the base type that are allowed in this <code>ItemDefinition</code> .
itemComponent: <code>ItemDefinition</code> [*]	This attribute defines zero or more nested <code>ItemDefinitions</code> that compose this <code>ItemDefinition</code> .
IsCollection: Boolean	Setting this flag to <i>true</i> indicates that the actual values defined by this <code>ItemDefinition</code> are collections of allowed values. The default is <i>false</i> .

7.3.3 InformationItem metamodel

The class `InformationItem` is used to model variables at the decision logic level in decision models.

InformationItem is a concrete subclass of NamedElement, from which it inherits the id, and optional name, description and label attributes, except that an InformationItem element SHALL have a name attribute, which is the name that is used to represent it in other Expression elements. The name of an InformationItem element SHALL be unique within its scope.

Variables represent values that result from a decision, are assigned to input data by an external data source, or are passed to a module of decision logic that is defined as a function (and that is represented by a business knowledge model element). In the first or second case, a variable may be referenced by other dependent decisions by means of their information requirements. In the third case, a variable is one of the parameters of the function that is the realization, at the decision logic level, of a business knowledge model element.

A variable representing an instance of Decision or InputData referenced by an InformationRequirement SHALL be referenced by the value expression of the decision logic in the Decision element that contains the InformationRequirement element. A parameter in an instance of BusinessKnowledgeModel SHALL be a variable in the value expression of that BusinessKnowledgeModel element."

An InformationItem element contained in a Decision is assigned the value of the Decision's value expression.

- An InformationItem element that is a parameter in a FunctionDefinition is assigned a value by a Binding element as part of an instance of Invocation.
- An InformationItem element contained in an InputData is assigned a value by an external data source that is attached at runtime.
- An InformationItem element contained in a ContextEntry is assigned a value by the ContextEntry's value expression.

In any case, the datatype indicated by the typeRef that is associated with an instance of InformationItem SHALL be compatible with the datatype that is associated with the DMN model element from which it takes its value. InformationItem inherits of all the attributes and model associations of NamedElement. Table 24 presents the additional attributes and model associations of the InformationItem element.

Table 24: InformationItem attributes and model associations

Attribute	Description
/valueExpression: Expression [0..1]	The Expression whose value is assigned to this InformationItem. This is a derived attribute
typeRef: QName [0..1]	Qualified name of the type of this InformationItem.

7.3.4 Literal expression metamodel

The class LiteralExpression is used to model a value expression whose value is specified by text in some specified expression language.

LiteralExpression is a concrete subclass of Expression, from which it inherits the id and typeRef attributes.

An instance of LiteralExpression has an optional text, which is a String, and an optional expressionLanguage, which is a String that identifies the expression language of the text. If no expressionLanguage is specified, the expression language of the text is the expressionLanguage that is associated with the containing instance of Definitions. The expressionLanguage SHALL be specified in a URI format. The default expression language is FEEL.

As a subclass of `Expression`, each instance of `LiteralExpression` has a value. The text in an instance of `LiteralExpression` determines its value, according to the semantics of the `LiteralExpression`'s `expressionLanguage`. The semantics of **DMN 1.1** decision models as described in this specification applies only if the text of all the instances of `LiteralExpression` in the model are valid expressions in their associated expression language.

An instance of `LiteralExpression` may include `importedValues`, which is an instance of a subclass `Import` that identifies where the text of the `LiteralExpression` is located. `importedValues` is an expression that selects text from an imported document. An instance of `LiteralExpression` SHALL NOT have both a text and `importedValues`. The `importType` of the `importedValues` identifies the type of document containing the imported text and SHALL be consistent with the `expressionLanguage` of the `LiteralExpression` element. The `expressionLanguage` of the `importedValues` element identifies how the imported text is selected from the imported document. For example, if the `importType` indicates an XML document, the `expressionLanguage` of `importedValues` could be XPATH 2.0.

`LiteralExpression` inherits of all the attributes and model associations of `Expression`. Table 25 presents the additional attributes and model associations of the `LiteralExpression` element.

Table 25: `LiteralExpression` attributes and model associations

Attribute	Description
text: string [0..1]	The text of this <code>LiteralExpression</code> . It SHALL be a valid expression in the <code>expressionLanguage</code> .
expressionLanguage: anyURI [0..1]	This attribute identifies the expression language used in this <code>LiteralExpression</code> . This value overrides the expression language specified for the containing instance of <code>DecisionRequirementDiagram</code> . The language SHALL be specified in a URI format.
importedValues: <code>ImportedValues</code> [0..1]	The instance of <code>ImportedValues</code> that specifies where the text of this <code>LiteralExpression</code> is located.

7.3.5 Invocation metamodel

Invocation is a mechanism that permits the evaluation of one value expression – the invoked expression – inside another value expression – the invoking expression – by binding locally the input variables of the invoked expression to values inside the invoking expression. In an invocation, the input variables of the invoked expression are usually called: *parameters*. Invocation permits the same value expression to be re-used in multiple expressions, without having to duplicate it as a sub-expression in all the using expressions.

The class `Invocation` is used to model invocations as a kind of `Expression`: `Invocation` is a concrete specialization of `Expression`.

An instance of `Invocation` is made of zero or more `binding`, which are instances of `Binding`, and model how the `bindingFormulas` are bound to the `formalParameters` of the invoked function. The `formalParameters` of a `FunctionDefinition` are `InformationItems` and the `parameters` of the `Bindings` are `InformationItems`. The binding is by matching the `InformationItem` names.

An `Invocation` contains a `calledFunction`, an `Expression`, which must evaluate to a function. Most commonly, it is a `LiteralExpression` naming a `BusinessKnowledgeModel`.

The value of an instance of `Invocation` is the value of the associated `calledFunction`'s body, with its `formalParameters` assigned values at runtime per the bindings in the `Invocation`.

`Invocation` MAY be used to model invocations in decision models, when a `Decision` element has exactly one `knowledgeRequirement` element, and when the `decisionLogic` in the `Decision` element consists only in invoking the `BusinessKnowledgeModel` element that is referenced by that `requiredKnowledge` and a more complex value expression is not required.

Using `Invocation` instances as the `decisionLogic` in `Decision` elements permits the re-use of the `encapsulatedLogic` of a `BusinessKnowledgeModel` as the logic for any instance of `Decision` that requires that `BusinessKnowledgeModel`, where each requiring `Decision` element specifies its own bindings for the `encapsulatedLogic`'s parameters.

The `calledFunction` that is associated with the `Invocation` element SHALL BE the `encapsulatedLogic` of the `BusinessKnowledgeModel` element that is required by the `Decision` element that contains the `Invocation`. The `Invocation` element SHALL have exactly one binding for each parameter in the `BusinessKnowledgeModel`'s `encapsulatedLogic`.

`Invocation` inherits of all the attributes and model associations of `Expression`. Table 26 presents the additional attributes and model associations of the `Invocation` element.

Table 26: Invocation attributes and model associations

Attribute	Description
calledFunction: <code>Expression</code> [1]	An expression whose value is a function.
binding: <code>Binding</code> [*]	This attribute lists the instances of <code>Binding</code> used to bind the <code>formalParameters</code> of the <code>calledFunction</code> in this <code>Invocation</code> .

7.3.6 Binding metamodel

The class `Binding` is used to model, in an `Invocation` element, the binding of the `calledFunction`'s `formalParameters` to values.

A `Binding` is made of one `bindingFormula`, which is an `Expression`, and of one parameter, which is an `InformationItem`.

The parameter names in the `Binding` elements SHALL be a subset of the `formalParameters` of the `calledFunction`.

When the `Invocation` element is executed, each `InformationItem` element that is referenced as a parameter by a binding in the `Invocation` element is assigned, at runtime, the value of the `bindingFormula`.

Table 27 presents the attributes and model associations of the `Binding` element.

Table 27: Binding attributes and model associations

Attribute	Description
parameter: InformationItem	The InformationItem on which the calledFunction of the owning instance of Invocation depends that is bound by this Binding.
bindingFormula: Expression [0..1]	The instance of Expression to which the parameter in this Binding is bound when the owning instance of Invocation is evaluated.

8 Decision Table

8.1 Introduction

One of the ways to express the decision logic corresponding to the DRD decision artifact is as a decision table. A decision table is a tabular representation of a set of related input and output expressions, organized into rules indicating which output entry applies to a specific set of input entries. The decision table contains all (and only) the inputs required to determine the output. Moreover, a complete table contains all possible combinations of input values (all the rules).

Decision tables and decision table hierarchies have a proven track record in decision logic representation. It is one of the purposes of **DMN** to standardize different forms and types of decision tables.

A decision table consists of:

- an information item name: the name of an InformationItem, if any, for which the decision table is its value expression. This will usually be the name of the Decision or Business Knowledge Model for which the decision table provides the decision logic.
- an output label, which can be any text to describe the output of the decision table. The result of a decision table must be referenced using the information item name, not the output label, in another expression.
- a set of inputs (zero or more). Each input is made of an input expression and a number of input entries. The specification of input expression and all input entries is referred to as the input clause.
- a set of outputs (one or more). A single output has no name, only a value. Two or more outputs are called output components. Each output component SHALL be named. Each output (component) SHALL specify an output entry for each rule. The specification of output component name (if multiple outputs) and all output entries is referred to as an output clause.
- a list of rules (one or more) in rows or columns of the table (depending on orientation), where each rule is composed of the specific input entries and output entries of the table row (or column). If the rules are expressed as rows, the columns are clauses, and vice versa.

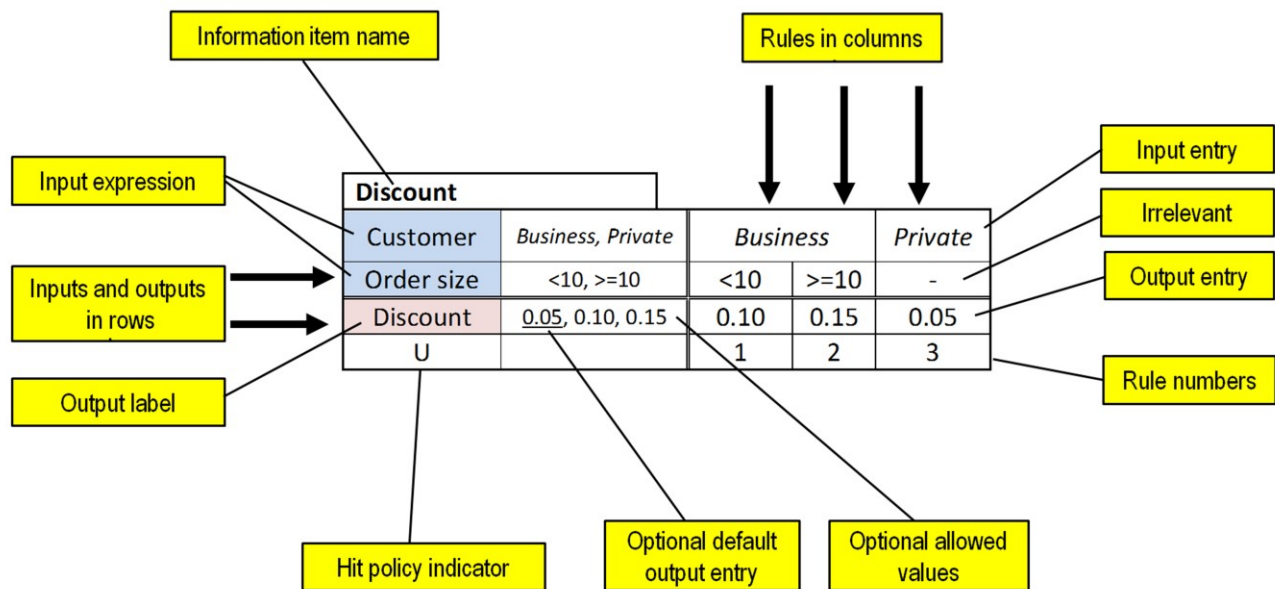

Figure 32: Decision table example (vertical orientation: rules as columns)

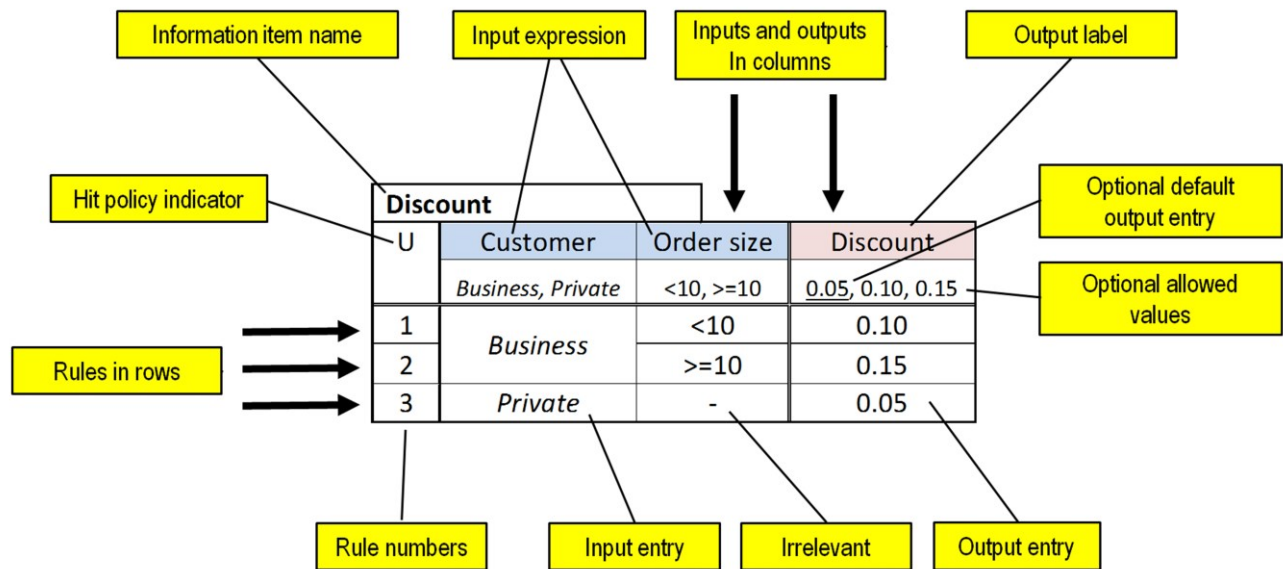

Figure 33: Decision table example (horizontal orientation: rules as rows)

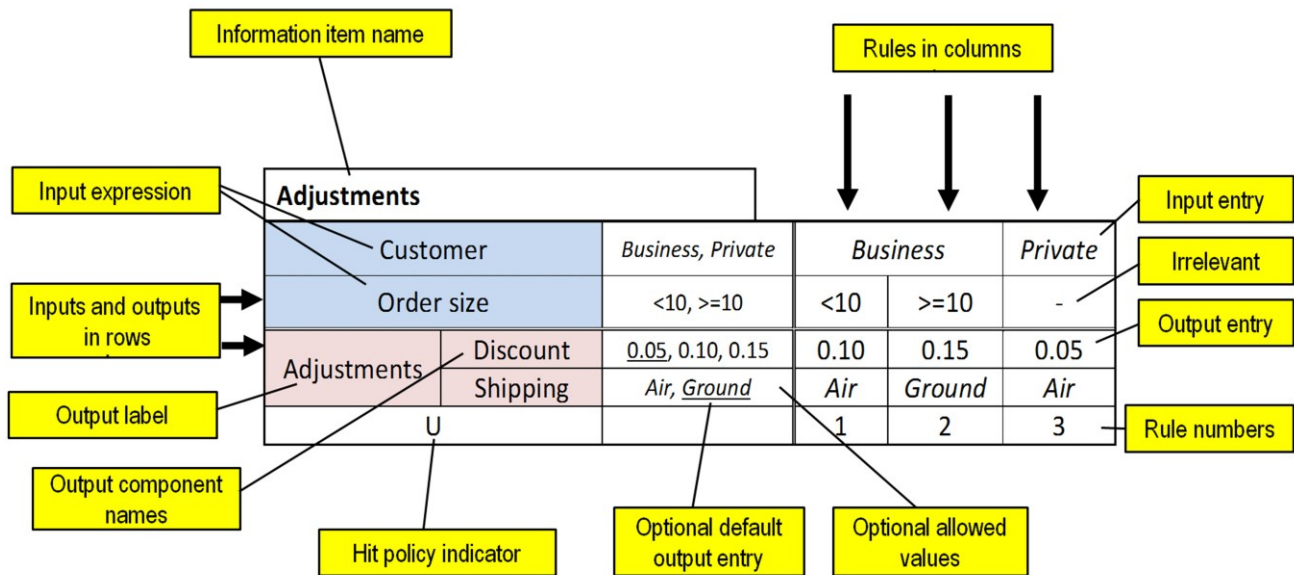

Figure 34: Decision table example (vertical orientation, multiple output components)

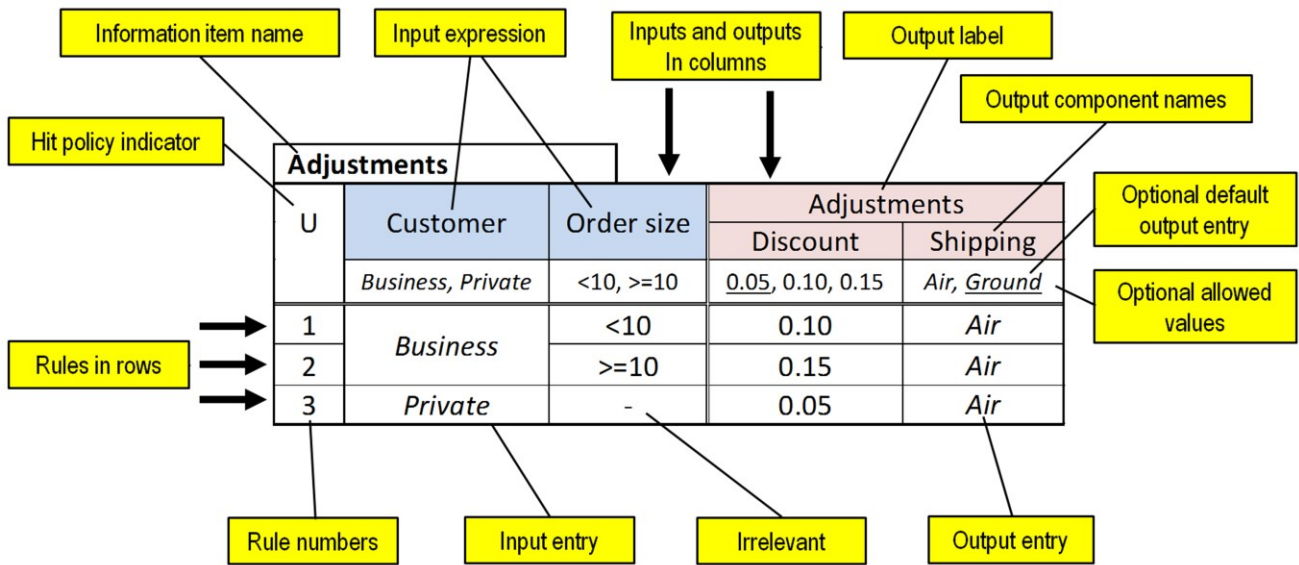

Figure 35: Decision table example (horizontal orientation, multiple output components)

The decision table shows the rules in a shorthand notation by arranging the entries in table cells. This shorthand notation shows all inputs in the same order in every rule and therefore has a number of readability and verification advantages.

For example:

Customer	OrderSize	Discount
<i>Business</i>	<10	0.10

reads as:

If Customer = “Business” **and** OrderSize < 10 **then** Discount = 0.10

In general, this is expressed as:

input expression 1	input expression 2	Output label
input entry a	input entry b	output entry c

The three highlighted cells in the decision table fragment above represent the following rule:

If the value of input expression 1 satisfies input entry a
and the value of input expression 2 satisfies input entry b
then the rule *matches* and the result of the decision table is output entry c.

An input expression value *satisfies* an input entry if the value is equal to the input entry, or belongs to the list of values indicated by the input entry (e.g. a list or a range). If the input entry is ‘-’ (meaning *irrelevant*), every value of the input expression satisfies the input entry and that particular input is irrelevant in the specified rule.

A rule *matches* if the value of every input expression satisfies the corresponding input entry. If there are no input entries, any rule matches.

The list of rules expresses the logic of the decision. For a given set of input values, the matching rule (or rules) indicate the resulting value for the output name. If rules *overlap*, multiple rules can match and a *hit policy* indicates how to handle the multiple matches.

If two input entries of the same input expression share no values, the entries (cells) are called *disjoint*. If there is an intersection, the entries are called *overlapping* (or even equal). ‘Irrelevant’ (‘-’) overlaps with any input entry of the input expression.

Two rules are overlapping if all corresponding input entries are *overlapping*. A specific configuration of input data may then match the two rules.

Two rules are *disjoint* (non-overlapping) if at least one pair of corresponding input expressions is disjoint. No specific configuration of input data will match the two rules.

If tables are allowed to contain overlapping rules, the table hit policy indicates how overlapping rules have to be handled and which is the resulting value(s) for the output name, in order to avoid inconsistency.

8.2 Notation

This section builds on the generic notation for decision logic and boxed expressions defined in clause 7.2.

A decision table representation standardizes:

- the orientation (rules as rows, columns or crosstab), as shown by the table
- placement of inputs, outputs and (optional) allowed values in standard locations on a grid of cells. Each input expression is optionally associated with unary tests restricting the allowed input values. In this text the optional cells with allowed values are indicated in *inverse*. Each output (component) is optionally associated with allowed values. In this text the optional allowed output values are indicated in *inverse*.
- line style and optional use of color
- the contents of specific rule input and output entry cells
- the hit policy, indicating how to interpret overlapping input combinations
- placement of information item name, hit policy (H) and rule numbers as indicated in Figure 36, Figure 38 and Figure 40. Rule numbers are consecutive natural numbers starting at 1. Rule numbering is required for tables with hit indicator F (first) or R (rule order), because the meaning depends on rule sequence. Crosstab tables have no rule numbers. Rule numbering is optional for other table types.

Input expressions, input values, output values, input entries and output entries can be any text (e.g. natural language, formal language, pseudo-code). Implementations claiming level 2 or 3 conformance SHALL support (S-)FEEL syntax.

Implementations claiming level 1 conformance are not required to interpret the expressions. To avoid misinterpretation (e.g. when expressions are not meant to be valid (S-)FEEL but may conflict with the look and feel of (S-)FEEL syntax), conformant implementations SHOULD indicate when the input expression is not meant to be interpreted by using the URI: "http://www.omg.org/spec/DMN/uninterpreted/20140801".

8.2.1 Line style and color

Line style is normative. There is a double line between the inputs section and the outputs section, and there is a double line between input/output expressions and the rule entry cells. Other cells are separated by a single line.

Color is suggested, but does not influence the meaning. It is considered good practice to use different colors for the input expressions section and the output name section, and another (or no) color for the rule entries.

8.2.2 Table orientation

Depending on size, a decision table can be presented horizontally (rules as rows), vertically (rules as columns), or crosstab (rules composed from two input dimensions). Crosstab tables can only have the default hit policy (see later).

Decision table inputs and outputs should not be mixed. In a horizontal table, all input columns SHALL be represented on the left of all output columns. In a vertical table, all the input rows SHALL be represented above all output rows. In a crosstab, all the output cells SHALL be in the bottom-right part of the table.

The table SHALL be arranged in one of the following ways (see Figure 36, Figure 38, Figure 40). Cells indicated in **inverse** are optional.

The input cell entry ‘-’ means ‘irrelevant’. HC is a placeholder for hit policy indicator (e.g. U, A, F, ...).

information item name			
H	input expression 1	input expression 2	Output label
	value 1a, value 1b	value 2a, value 2b	value 1a, value 1b
1	input entry 1.1	input entry 2.1	output entry 1.1
2		input entry 2.2	output entry 1.2
3	input entry 1.2	-	output entry 1.3

Figure 36: Rules as rows – schematic layout

Discount				
U	Customer	OrderSize	Delivery	Discount
	<i>Business, Private, Government</i>	<10, >=10	<i>sameday, slow</i>	0, 0.05, 0.10, 0.15
1	<i>Business</i>	<10	-	0.05
2		>=10	-	0.10
3	<i>Private</i>	-	<i>sameday</i>	0
4			<i>slow</i>	0.05
5	<i>Government</i>	-	-	0.15

Figure 37: Rules as rows – example

information item name				
input expression 1	value 1a, value 1b	input entry 1.1		input entry 1.2
input expression 2	value 2a, value 2b	input entry 2.1	input entry 2.2	-
Output label	value 1a, value 1b	output entry 1.1	output entry 1.2	output entry 1.3
H		1	2	3

Figure 38: Rules as columns – schematic layout

Discount		Business		Private		Government
Customer	<i>Business, Private, Government</i>					
Ordersize	<10, >=10	<10	>=10	-		-
Delivery	<i>sameday, slow</i>	-	-	<i>sameday</i>	<i>slow</i>	-
Discount	0, 0.05, 0.10, 0.15	0.05	0.10	0	0.05	0.15
U		1	2	3	4	5

Figure 39: Rules as columns – example

information item name		input expression 1	
Output label		input entry 1.1	input entry 1.2
		output entry 1.1	output entry 1.3
input expression 2	input entry 2.1	output entry 1.1	output entry 1.3
	input entry 2.2	output entry 1.2	output entry 1.4

Figure 40: Rules as crosstab – schematic layout (optional input and output values not shown)

Discount		Customer		
Discount		<i>Business</i>	<i>Private</i>	<i>Government</i>
Ordersize	<10	0.05	0	0.15
	>=10	0.10	0	0.15

Figure 41: Rules as crosstab – simplified example with only two inputs

Discount		Customer, Delivery			
Discount		<i>Business</i>	<i>Private</i>		<i>Government</i>
		-	<i>sameday</i>	<i>slow</i>	-
Ordersize	<10	0.05	0	0.05	0.15
	>=10	0.10	0	0.05	0.15

Figure 42: Rules as crosstab - example with three inputs

Crosstab tables with more than two inputs are possible (as shown in Figure 42).

8.2.3 Input expressions

Input expressions are usually simple, for example, a name (e.g. CustomerStatus) or a test (e.g. Age<25).

The order of input expressions is not related to any execution order in implementation.

8.2.4 Input values

Input expressions may be expected to result in a limited number or a limited range of values. It is important to model these expected input values, because a decision table will be considered complete if its rules cover all combinations of expected input values for all input expressions.

Regardless of how the expected input values are modeled, input values SHOULD be exclusive and complete. Exclusive means that input values are disjoint. Complete means that all relevant input values from the domain are present.

For example, the following two input value ranges overlap: <5, <10. The following two ranges are incomplete: <5, >5.

The list of input values is optional. If provided, it is a list of unary tests that must be satisfied by the corresponding input.

8.2.5 Information Item names, output labels, and output component names

A decision table with multiple output components SHALL specify a name for each output component.

A decision table that is the value expression of an InformationItem (e.g. a Decision's logic or a boxed Invocation's binding formula) SHALL specify the name of the InformationItem as its Information Item name. A decision table that is not contained in another boxed expression shall place the Information Item name in a name box just above and adjoining the table.

A decision table that is contained in another boxed expression may use the containing expression for its Information Item name. For example, the Information Item name for a decision table bound to a function parameter is the name of the function parameter. Or, to save space, the Information Item name box may be omitted and the Output label used instead.

8.2.6 Output values

The output entries of a decision table are often drawn from a list of output values.

The list of output values is optional. If provided, it is a list restricting output entries to the given list of values.

When the hit policy is P (priority), meaning that multiple rules can match, but only one hit should be returned, the ordering of the list of output values is used to specify the (decreasing) priority.

The ordering of the list of output values is also used when the hit policy is output order.

8.2.7 Multiple outputs

The decision table can show a compound output (see **Figure 43**, **Figure 44**, **Figure 45**).

information item name				
H	input expression 1	input expression 2	output label	
			output component 1	output component 2
	input value 1a, input value 1b	input value 2a, input value 2b	output value 1a, output value 1b	output value 2a, output value 2b
1	input entry 1a	input entry 2a	output entry 1.1	output entry 2.1
2		input entry 2b	output entry 1.2	output entry 2.2
3	input entry 1b	-	output entry 1.3	output entry 2.3

Figure 43: Horizontal table with multiple output components

information item name					
input expression 1		input value 1a, input value 1b	input entry 1a		input entry 1b
input expression 2		input value 2a, input value 2b	input entry 2a	input entry 2b	-
output label	output component 1	output value 1a, output value 1b	output entry 1.1	output entry 1.2	output entry 1.3
	output component 2	output value 2a, output value 2b	output entry 2.1	output entry 2.2	output entry 2.3
H			1	2	3

Figure 44: Vertical table with multiple output components

information item name			
output label		input expression 1	
output component 1, output component 2		input entry 1a	input entry 1b
input expression 2	input entry 2a	output entry 1.1, output entry 2.1	output entry 1.3 output entry 2.3
	input entry 2b	output entry 1.2, output entry 2.2	output entry 1.4, output entry 2.4

Figure 45: Crosstab with multiple output components

8.2.8 Input entries

Rule input entries are expressions.

A dash symbol ('-') can be used to mean any input value, *i.e.*, the input is irrelevant for the containing rule.

The input entries in a unary test SHOULD be '-' or a subset of the input values specified. For example, if the input values for input 'Age' are specified as $[0..120]$, then an input entry of <0 SHOULD be reported as invalid.

Tables containing at least one '-' input entry are called *contracted* tables. The others are called *expanded*.

Tables where every input entry is *true*, *false*, or *'-'* are historically called *limited-entry* tables, but there is no need to maintain this restriction.

Evaluation of the input expressions in a decision table does not produce side-effects that influence the evaluation of other input expressions. This means that evaluating an expression or executing a rule should not change the evaluation of other expressions or rules of the same table. This is particularly important in first hit tables where the rules are evaluated in a predefined sequence: evaluating or executing a rule should not influence other rules.

8.2.9 Merged input entry cells

Adjacent input entry cells from different rules, with the same content and same (or no) prior cells can be merged, as shown in **Figure 46** and **Figure 47**. Rule output cells cannot be merged (except in crosstabs).

information item name			
H	input expression 1	input expression 2	Output label
	input value 1a, input value 1b	input value 2a, input value 2b	output value 1a, output value 1b
1	input entry 1a	input entry 2a	output entry 1.1
2		input entry 2b	output entry 1.2
3	input entry 1b	-	output entry 1.3

Figure 46: Merged rule input cells allowed

information item name			
H	input expression 1	input expression 2	Output label
	input value 1a, input value 1b	input value 2a, input value 2b	output value 1a, output value 1b
1	input entry 1a	input entry 2a	output entry 1.1
2		input entry 2b	output entry 1.2
3	input entry 1b	input entry 2b	output entry 1.3
4		input entry 2a	output entry 1.4

Figure 47: Merged rule input cells not allowed

8.2.10 Output entry

A rule output entry is an expression.

Rule output cells cannot be merged (except in crosstabs, where adjacent output cells with the same content can be merged).

Shorthand notation

In vertical (rules as columns) tables with a single output name (equal to the information item name), a shorthand notation may be used to indicate: output value applies ('X') or does not apply ('-'), as is common practice in decision tables.

Because there can be only one output entry for an output name, every rule must indicate no more than one 'X'. The other output entries must contain '-'.

The table in Figure 48 is shorthand notation for the table in Figure 49. It is called shorthand, because the output entries need not be (re-)written in every column, but are indicated with a one-character notation ('X' or '-'), thereby saving space in vertical tables, which tend to expand in width as the number of rules increases. The output values are written only once, before the rules, in the output expression part.

If an information item name is provided, and there is only one output name (which has to be equal to the information item name), the output name is optional.

Applicant Risk Rating					
Applicant Age	< 25		[25..60]	> 60	
Medical History	<i>good</i>	<i>bad</i>	-	<i>good</i>	<i>bad</i>
<i>Low</i>	X	-	-	-	-
<i>Medium</i>	-	X	X	X	-
<i>High</i>	-	-	-	-	X
U	1	2	3	4	5

Figure 48: Shorthand notation for vertical tables (rules as columns)

Applicant Risk Rating					
Applicant Age	< 25		[25..60]	> 60	
Medical History	<i>good</i>	<i>bad</i>	-	<i>good</i>	<i>bad</i>
Applicant Risk Rating	<i>Low</i>	<i>Medium</i>	<i>Medium</i>	<i>Medium</i>	<i>High</i>
U	1	2	3	4	5

Figure 49: Full notation for vertical tables (rules as columns)

8.2.11 Hit policy

A decision table normally has several rules. As a default, rules do not overlap. If rules overlap, meaning that more than one rule may match a given set of input values, the hit policy indicator is required in order to recognize the table type and unambiguously understand the decision logic. The hit policy can be used to check correctness at design-time.

The hit policy specifies what the result of the decision table is in cases of overlapping rules, i.e. when more than one rule matches the input data. For clarity, the hit policy is summarized using a single character in a particular decision table cell. In horizontal tables this is the top-left cell (Figure 33) and in vertical tables this is the bottom-left cell (Figure 32). The character is the initial letter of the defined hit policy (Unique, Any, Priority, First, Collect, Output order or Rule order). Crosstab tables are always Unique and need no indicator.

The hit policy SHALL default to Unique, in which case the hit indicator is optional. Decision tables with the Unique hit policy SHALL NOT contain overlapping rules.

Tools may support only a nonempty subset of hit policies, but the table type SHALL be clear and therefore the hit policy indication is mandatory, except for the default unique tables. Unique tables SHALL always be supported.

Single and multiple hit tables

A single hit table shall return the output of one rule only; a multiple hit table may return the output of multiple rules (or a function of the outputs, e.g. sum of values). If rules are allowed to overlap, the hit policy indicates how overlapping rules have to be interpreted.

The initial letter for hit policy also identifies if a table is single hit or multiple hit.

A single hit table may or may not contain overlapping rules, but returns the output of one rule only. In case of overlapping rules, the hit policy indicates which of the matching rules to select. Some restrictions apply to tables with compound outputs.

Single hit policies for single output decision tables are:

1. **Unique:** no overlap is possible and all rules are disjoint. Only a single rule can be matched. This is the default.
2. **Any:** there may be overlap, but all of the matching rules show equal output entries for each output, so any match can be used. If the output entries are non-equal, the hit policy is incorrect and the result is undefined.
3. **Priority:** multiple rules can match, with different output entries. This policy returns the matching rule with the highest output priority. Output priorities are specified in the ordered list of output values, in decreasing order of priority. Note that priorities are independent from rule sequence.
4. **First:** multiple (overlapping) rules can match, with different output entries. The first hit by rule order is returned (and evaluation can halt). This is still a common usage, because it resolves inconsistencies by forcing the first hit. However, first hit tables are not considered good practice because they do not offer a clear overview of the decision logic. It is important to distinguish this type of table from others because the meaning depends on the order of the rules. The last rule is often the catch-remainder. Because of this order, the table is hard to validate manually and therefore has to be used with care.

A multiple hit table may return output entries from multiple rules. The result will be a list of rule outputs or a simple function of the outputs.

Multiple hit policies for single output decision tables can be:

5. **Output order:** returns all hits in decreasing output priority order. Output priorities are specified in the ordered list of output values in decreasing order of priority.
6. **Rule order:** returns all hits in rule order. Note: the meaning may depend on the sequence of the rules.
7. **Collect:** returns all hits in arbitrary order. An operator ('+', '<', '>', '#') can be added to apply a simple function to the outputs. If no operator is present, the result is the list of all the output entries.
Collect operators are:
 - a) + (sum): the result of the decision table is the sum of all the distinct outputs.
 - b) < (min): the result of the decision table is the smallest value of all the outputs.
 - c) > (max): the result of the decision table is the largest value of all the outputs.
 - d) # (count): the result of the decision table is the number of distinct outputs.Other policies, such as more complex manipulations on the outputs, can be performed by post-processing the output list (outside the decision table).

Decision tables with compound outputs support only the following hit policies: Unique, Any, Priority, First, Output order, Rule order and Collect without operator, because the collect operator is undefined over multiple outputs.

For the Priority and Output order hit policies, priority is decided in compound output tables over all the outputs for which output values have been provided. The priority for each output is specified in the ordered list of output values in decreasing order of priority, and the overall priority is established by considering the ordered outputs from left to right in horizontal tables (i.e. columns to the left take precedence over columns to the right), or from top to bottom in vertical tables. Outputs for which no output values are provided are not taken into account in the ordering, although their output entries are included in the ordered compound output.

So, for example, if called with Age = 17, Risk category = "HIGH" and Debt review = true, the Routing rules table in Figure 50 would return the outputs of all four rules, in the order 2, 4, 3, 1.

Routing rules						
0	Age	Risk category	Debt review	Routing	Review level	Reason
		<i>LOW, MEDIUM, HIGH</i>		<i>DECLINE, REFER, ACCEPT</i>	<i>LEVEL 2, LEVEL 1, NONE</i>	
1	-	-	-	<i>ACCEPT</i>	<i>NONE</i>	<i>Acceptable</i>
2	< 18	-	-	<i>DECLINE</i>	<i>NONE</i>	<i>Applicant too young</i>
3	-	<i>HIGH</i>	-	<i>REFER</i>	<i>LEVEL 1</i>	<i>High risk application</i>
4	-	-	true	<i>REFER</i>	<i>LEVEL 2</i>	<i>Applicant under debt review</i>

Figure 50: Output order with compound output

Note 1

Crosstab tables are unique and complete by definition and therefore do not need a hit policy.

Note 2

The sequence of the rules in a decision table does not influence the meaning, except in **F**irst tables (single hit) and **R**ule order tables (multiple hit). These tables should be used with care.

8.2.12 Default output values

Tables may specify a default output. The default value is underlined in the list of output values.

8.3 Metamodel

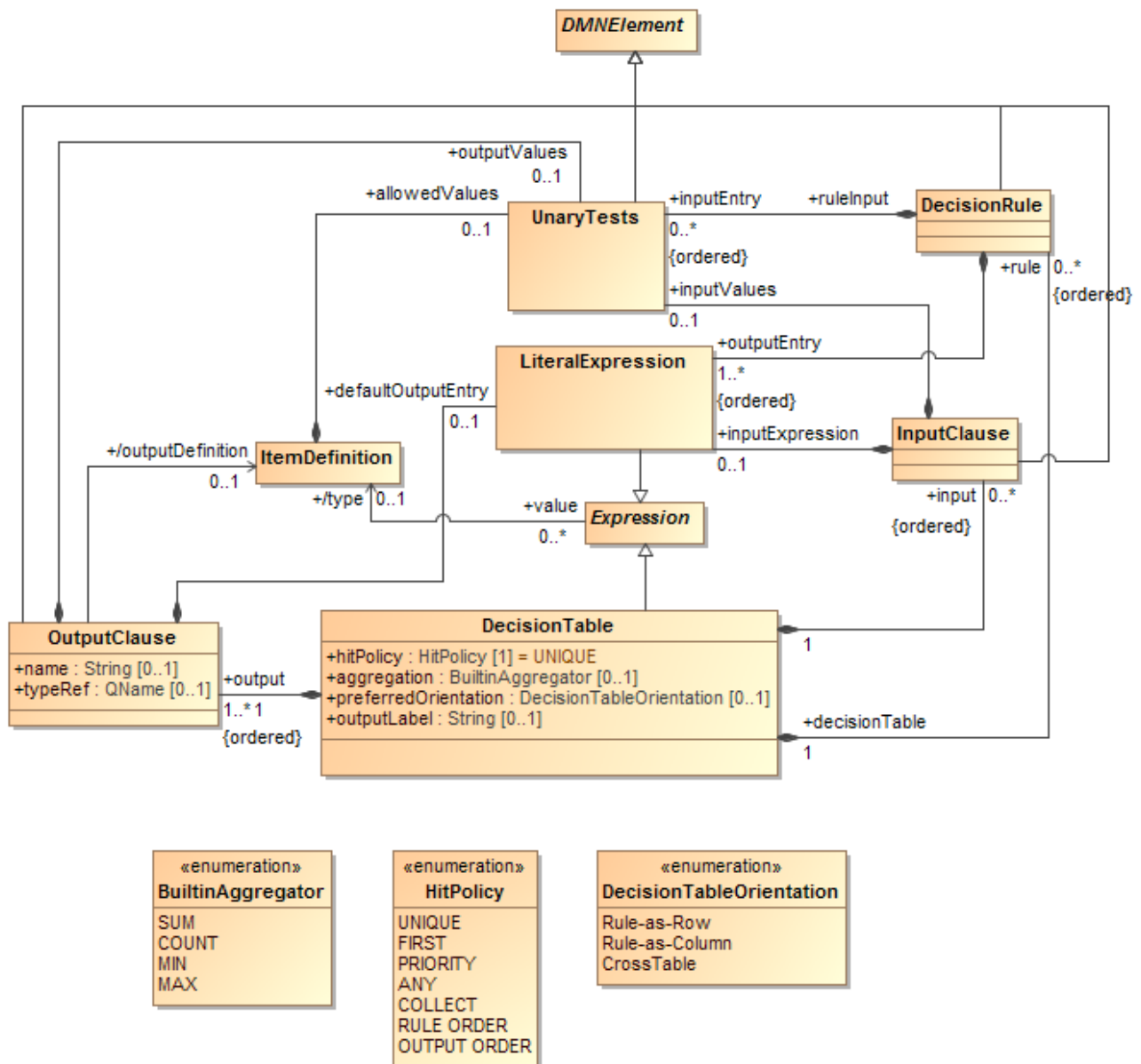

Figure 51: DecisionTable class diagram

8.3.1 Decision Table metamodel

The class `DecisionTable` is used to model a decision table.

`DecisionTable` is a concrete specialization of `Expression`.

An instance of `DecisionTable` contains a set of rules, which are instances of `DecisionRule`, a set of inputs, which are instances of `InputClause`, and a set of outputs, which are instances of `OutputClause`.

It has a `preferredOrientation`, which SHALL be one of the enumerated `DecisionTableOrientation`: `Rule-as-Row`, `Rule-as-Column` or `CrossTable`. An instance of `DecisionTable` SHOULD BE represented as specified by its `preferredOrientation`, as defined in clause 8.2.2.

An instance of `DecisionTable` has an associated `hitPolicy`, which SHALL be one of the enumerated `HitPolicy`: `UNIQUE`, `FIRST`, `PRIORITY`, `ANY`, `COLLECT`, `RULE ORDER`, `OUTPUT ORDER`. The default value for the `hitPolicy` attribute is: `UNIQUE`. In the diagrammatic representation of an instance of `DecisionTable`, the `hitPolicy` is represented as specified in clause 8.2.11.

The semantics that is associated with an instance of `DecisionTable` depends on its associated `hitPolicy`, as specified below and in clause 8.2.11. The `hitPolicy` attribute of an instance of `DecisionTable` is represented as specified in clause 8.2.11.

If the `hitPolicy` associated with an instance of `DecisionTable` is `FIRST` or `RULE ORDER`, the rules that are associated with the `DecisionTable` SHALL be ordered. The ordering is represented by the explicit numbering of the rules in the diagrammatic representation of the `DecisionTable`.

If the `hitPolicy` associated with an instance of `DecisionTable` is `PRIORITY` or `OUTPUT ORDER`, the `outputValues` determine the result as specified in clause 8.2.11.

If the `hitPolicy` that is associated with an instance of `DecisionTable` is `COLLECT`, the `DecisionTable` MAY have an associated aggregation, which is one of the enumerated `BuiltinAggregator` (see clause 8.2.11).

As a kind of `Expression`, an instance of `DecisionTable` has a value, which depends on the outputs of the associated rules, the associated `hitPolicy` and the associated aggregation, if any. The value of an instance of `DecisionTable` is determined according to the following specification:

- if the associated `hitPolicy` is `UNIQUE`, the value of an instance of `DecisionTable` is the value of the conclusion of the only applicable rule (see clause 8.3.3, `Decision Rule`, for the definition of rule applicability);
- if the associated `hitPolicy` is `FIRST`, the value of an instance of `DecisionTable` is the value of the conclusion of the first applicable rule, according to the rule ordering;
- if the associated `hitPolicy` is `PRIORITY`, the value of an instance of `DecisionTable` is the value of the conclusion of the of the first applicable rule, according to the ordering of the `outputEntry` in the list of output values;
- if the associated `hitPolicy` is `ANY`, the value of an instance of `DecisionTable` is the value of any of the applicable rules;
- if the associated `hitPolicy` is `COLLECT` and an aggregation is specified, the value of an instance of `DecisionTable` is the result of applying the aggregation function specified by the aggregation attribute of the `DecisionTable` to the unordered set of the values of the conclusions of all the applicable rules; if the aggregation attribute is not specified, the value of the decision table is the unordered set itself;
- if the associated `hitPolicy` is `RULE ORDER`, the value of an instance of `DecisionTable` is the list of the values of the conclusions of all the applicable rules, ordered according to the rule ordering;
- if the associated `hitPolicy` is `OUTPUT ORDER`, the value of an instance of `DecisionTable` is the list of the values of the conclusions of all the applicable rules, ordered according to the ordering of the `outputEntry` in the conclusion.

`DecisionTable` inherits all the attributes and model associations from `Expression`. Table 28 presents the additional attributes and model associations of the `DecisionTable` element.

Table 28: DecisionTable attributes and model associations

Attribute	Description
input: InputClause [*]	This attributes lists the instances of InputClause that compose this DecisionTable.
output: OutputClause [*]	This attributes lists the instances of OutputClause that compose this DecisionTable.
rule: DecisionRule [*]	This attributes lists the instances of DecisionRule that compose this DecisionTable.
hitPolicy: HitPolicy	The hit policy that determines the semantics of this DecisionTable. Default is: UNIQUE.
aggregation: BuiltinAggregator	If present, this attribute specifies the aggregation function to be applied to the unordered set of values of the applicable rules to determine the value of this DecisionTable when the hitPolicy is COLLECT.
preferredOrientation: DecisionTableOrientation [0..1]	The preferred orientation for the diagrammatic representation of this DecisionTable. This DecisionTable SHOULD BE represented as specified by this attribute.
outputLabel: string[0..1]	This attribute gives a description of the decision table output, and is often the same as the name of the InformationItem for which the decision table is the value expression.

8.3.2 Decision Table Input and Output metamodel

In a DecisionTable, an input specifies an inputExpression (the subject) and a number of inputEntries. An output specifies the name and the domain of definition of an output value, a number of outputEntries.

The class InputClause is used to model a decision table input, and the class OutputClause is used to model a decision table output.

An instance of InputClause is made of an optional inputExpression and an ordered list of inputEntry, which are instances of UnaryTests. An instance of OutputClause optionally references a typeRef, specifying its datatype, and it is made of an ordered list of outputEntry, which are instances of LiteralExpression, and an optional defaultOutputEntry, which is also an instance of LiteralExpression.

When a DecisionTable contains more than one OutputClause, each OutputClause SHALL have a name. When a DecisionTable has a single OutputClause, the OutputClause SHALL NOT have a name.

Tables 25a and 25b present the attributes and model associations of InputClause and OutputClause.

Table 29a: InputClause attributes and model associations

Attribute	Description
-----------	-------------

inputExpression: Expression [0.1]	The subject of this InputClause.
inputEntry: Expression [*]	This attribute lists the instances of Expression that compose this InputClause.

Table 25b: OutputClause attributes and model associations

Attribute	Description
typeRef: QName [0..1]	The OutputClause of a single output decision table SHALL NOT specify a typeRef. OutputClauses of a multiple output decision table MAY specify a typeRef. A typeRef is the name of the datatype of the output, either an ItemDefinition, a base type in the specified expressionLanguage, or an imported type.
name: string [0.1]	The OutputClause of a single output decision table SHALL NOT specify a name. OutputClauses of a multiple output decision table SHALL specify a name.
outputEntry: Expression [*]	This attribute lists the instances of Expression that compose this OutputClause.
defaultOutputEntry: Expression [0.1]	In an Incomplete table, this attribute lists an instance of Expression that is selected when no rules match for the decision table.

8.3.3 Decision Rule metamodel

The class `DecisionRule` is used to model the rules in a decision table (see clause 8.2).

An instance of `DecisionRule` has an ordered list of `inputEntry` instances which are instances of `UnaryTests`, and an ordered list of `outputEntry` instances, which are instances of `LiteralExpression`.

In a tabular representation of the containing instance of `DecisionTable`, the representation of an instance of `DecisionRule` depends on the orientation of the decision table. For instance, if the decision table is represented horizontally (rules as row, see clause 8.2.2), instances of `DecisionRule` are represented as rows, with all the `inputEntries` represented on the left of all the `outputEntries`.

By definition, a `DecisionRule` element that has no `inputEntries` is always applicable. Otherwise, an instance of `DecisionRule` is said to be *applicable* if and only if, at least one of the rule's `inputEntries` match their corresponding `inputExpression` value. The `inputEntries` are matched in arbitrary order.

The `inputEntry` elements SHALL be in the same order as the containing `DecisionTable`'s inputs.

The i^{th} `inputExpression` must satisfy the i^{th} `inputEntry` for all `inputEntries` in order for the `DecisionRule` to *match*, as defined in section 8.1.

The `outputEntry` elements SHALL be in the same order as the containing `DecisionTable`'s outputs.

The i^{th} `outputEntry` SHALL be consistent with the `typeRef` of the i^{th} `OutputClause`.

Table 30 presents the attributes and model associations of the `DecisionRule` element.

Table 30: DecisionRule attributes and model associations

Attribute	Description
inputEntry: UnaryTests[0..*]	The instances of <code>UnaryTests</code> that specify the input conditions that this <code>DecisionRule</code> must match for the corresponding (by index) <code>inputExpression</code> .
outputEntry: LiteralExpression [1..*]	A list of the instances of <code>LiteralExpression</code> that compose the output components of this <code>DecisionRule</code> .

8.4 Examples

Table 31 provides examples for the various types of decision table discussed in this section. Further examples may be found in 11.3, in the context of a complete example of a **DMN** decision model.

Table 31: Examples of decision tables

Single Hit Unique	<table border="1"> <thead> <tr> <th colspan="4">Applicant Risk Rating</th> </tr> <tr> <th>U</th> <th>Applicant Age</th> <th>Medical History</th> <th>Applicant Risk Rating</th> </tr> </thead> <tbody> <tr> <td>1</td> <td rowspan="2">> 60</td> <td><i>good</i></td> <td><i>Medium</i></td> </tr> <tr> <td>2</td> <td><i>bad</i></td> <td><i>High</i></td> </tr> <tr> <td>3</td> <td>[25..60]</td> <td>-</td> <td><i>Medium</i></td> </tr> <tr> <td>4</td> <td rowspan="2">< 25</td> <td><i>good</i></td> <td><i>Low</i></td> </tr> <tr> <td>5</td> <td><i>bad</i></td> <td><i>Medium</i></td> </tr> </tbody> </table>	Applicant Risk Rating				U	Applicant Age	Medical History	Applicant Risk Rating	1	> 60	<i>good</i>	<i>Medium</i>	2	<i>bad</i>	<i>High</i>	3	[25..60]	-	<i>Medium</i>	4	< 25	<i>good</i>	<i>Low</i>	5	<i>bad</i>	<i>Medium</i>															
	Applicant Risk Rating																																									
	U	Applicant Age	Medical History	Applicant Risk Rating																																						
1	> 60	<i>good</i>	<i>Medium</i>																																							
2		<i>bad</i>	<i>High</i>																																							
3	[25..60]	-	<i>Medium</i>																																							
4	< 25	<i>good</i>	<i>Low</i>																																							
5		<i>bad</i>	<i>Medium</i>																																							
<table border="1"> <thead> <tr> <th colspan="6">Applicant Risk Rating</th> </tr> <tr> <th>Applicant Age</th> <th colspan="2">< 25</th> <th>[25..60]</th> <th colspan="2">> 60</th> </tr> <tr> <th>Medical History</th> <th><i>good</i></th> <th><i>bad</i></th> <th>-</th> <th><i>good</i></th> <th><i>bad</i></th> </tr> <tr> <th>Applicant Risk Rating</th> <th><i>Low</i></th> <th><i>Medium</i></th> <th><i>Medium</i></th> <th><i>Medium</i></th> <th><i>High</i></th> </tr> <tr> <th>U</th> <td>1</td> <td>2</td> <td>3</td> <td>4</td> <td>5</td> </tr> </thead> </table>	Applicant Risk Rating						Applicant Age	< 25		[25..60]	> 60		Medical History	<i>good</i>	<i>bad</i>	-	<i>good</i>	<i>bad</i>	Applicant Risk Rating	<i>Low</i>	<i>Medium</i>	<i>Medium</i>	<i>Medium</i>	<i>High</i>	U	1	2	3	4	5												
Applicant Risk Rating																																										
Applicant Age	< 25		[25..60]	> 60																																						
Medical History	<i>good</i>	<i>bad</i>	-	<i>good</i>	<i>bad</i>																																					
Applicant Risk Rating	<i>Low</i>	<i>Medium</i>	<i>Medium</i>	<i>Medium</i>	<i>High</i>																																					
U	1	2	3	4	5																																					
<table border="1"> <thead> <tr> <th colspan="6">Applicant Risk Rating</th> </tr> <tr> <th>Applicant Age</th> <th colspan="2">< 25</th> <th>[25..60]</th> <th colspan="2">> 60</th> </tr> <tr> <th>Medical History</th> <th><i>good</i></th> <th><i>bad</i></th> <th>-</th> <th><i>good</i></th> <th><i>bad</i></th> </tr> <tr> <th><i>Low</i></th> <td>X</td> <td>-</td> <td>-</td> <td>-</td> <td>-</td> </tr> <tr> <th><i>Medium</i></th> <td></td> <td>X</td> <td>X</td> <td>X</td> <td></td> </tr> <tr> <th><i>High</i></th> <td></td> <td></td> <td></td> <td></td> <td>X</td> </tr> <tr> <th>U</th> <td>1</td> <td>2</td> <td>3</td> <td>4</td> <td>5</td> </tr> </thead> </table>	Applicant Risk Rating						Applicant Age	< 25		[25..60]	> 60		Medical History	<i>good</i>	<i>bad</i>	-	<i>good</i>	<i>bad</i>	<i>Low</i>	X	-	-	-	-	<i>Medium</i>		X	X	X		<i>High</i>					X	U	1	2	3	4	5
Applicant Risk Rating																																										
Applicant Age	< 25		[25..60]	> 60																																						
Medical History	<i>good</i>	<i>bad</i>	-	<i>good</i>	<i>bad</i>																																					
<i>Low</i>	X	-	-	-	-																																					
<i>Medium</i>		X	X	X																																						
<i>High</i>					X																																					
U	1	2	3	4	5																																					
Single Hit Any	<table border="1"> <thead> <tr> <th colspan="5">Person Loan Compliance</th> </tr> <tr> <th>A</th> <th>Persons Credit Rating from Bureau</th> <th>Person Credit Card Balance</th> <th>Person Education Loan Balance</th> <th>Person Loan Compliance</th> </tr> </thead> <tbody> <tr> <td>1</td> <td>A</td> <td>< 10000</td> <td>< 50000</td> <td><i>Compliant</i></td> </tr> <tr> <td>2</td> <td>Not(A)</td> <td>-</td> <td>-</td> <td><i>Not Compliant</i></td> </tr> <tr> <td>3</td> <td>-</td> <td>>= 10000</td> <td>-</td> <td><i>Not Compliant</i></td> </tr> <tr> <td>4</td> <td>-</td> <td>-</td> <td>>= 50000</td> <td><i>Not Compliant</i></td> </tr> </tbody> </table> <p><i>Example case: not A, >= \$10K, >= 50K -> Not Compliant (rules 2,3,4)</i></p>	Person Loan Compliance					A	Persons Credit Rating from Bureau	Person Credit Card Balance	Person Education Loan Balance	Person Loan Compliance	1	A	< 10000	< 50000	<i>Compliant</i>	2	Not(A)	-	-	<i>Not Compliant</i>	3	-	>= 10000	-	<i>Not Compliant</i>	4	-	-	>= 50000	<i>Not Compliant</i>											
Person Loan Compliance																																										
A	Persons Credit Rating from Bureau	Person Credit Card Balance	Person Education Loan Balance	Person Loan Compliance																																						
1	A	< 10000	< 50000	<i>Compliant</i>																																						
2	Not(A)	-	-	<i>Not Compliant</i>																																						
3	-	>= 10000	-	<i>Not Compliant</i>																																						
4	-	-	>= 50000	<i>Not Compliant</i>																																						

<p>Single Hit Priority</p>	<table border="1"> <thead> <tr> <th colspan="4">Applicant Risk Rating</th> </tr> <tr> <th>P</th> <th>Applicant Age</th> <th>Medical History</th> <th>Applicant Risk Rating</th> </tr> </thead> <tbody> <tr> <td></td> <td></td> <td></td> <td><i>High, Medium, Low</i></td> </tr> <tr> <td>1</td> <td>≥ 25</td> <td><i>good</i></td> <td><i>Medium</i></td> </tr> <tr> <td>2</td> <td>> 60</td> <td><i>bad</i></td> <td><i>High</i></td> </tr> <tr> <td>3</td> <td>-</td> <td><i>bad</i></td> <td><i>Medium</i></td> </tr> <tr> <td>4</td> <td>< 25</td> <td><i>good</i></td> <td><i>Low</i></td> </tr> </tbody> </table>	Applicant Risk Rating				P	Applicant Age	Medical History	Applicant Risk Rating				<i>High, Medium, Low</i>	1	≥ 25	<i>good</i>	<i>Medium</i>	2	> 60	<i>bad</i>	<i>High</i>	3	-	<i>bad</i>	<i>Medium</i>	4	< 25	<i>good</i>	<i>Low</i>																										
Applicant Risk Rating																																																							
P	Applicant Age	Medical History	Applicant Risk Rating																																																				
			<i>High, Medium, Low</i>																																																				
1	≥ 25	<i>good</i>	<i>Medium</i>																																																				
2	> 60	<i>bad</i>	<i>High</i>																																																				
3	-	<i>bad</i>	<i>Medium</i>																																																				
4	< 25	<i>good</i>	<i>Low</i>																																																				
<p>Single Hit First</p>	<table border="1"> <thead> <tr> <th colspan="5">Special Discount</th> </tr> <tr> <th>F</th> <th>Type of Order</th> <th>Customer Location</th> <th>Type of Customer</th> <th>Special Discount %</th> </tr> </thead> <tbody> <tr> <td>1</td> <td><i>Web</i></td> <td><i>US</i></td> <td><i>Wholesaler</i></td> <td>10</td> </tr> <tr> <td>2</td> <td><i>Phone</i></td> <td>-</td> <td>-</td> <td>0</td> </tr> <tr> <td>3</td> <td>-</td> <td><i>Non-US</i></td> <td>-</td> <td>0</td> </tr> <tr> <td>4</td> <td>-</td> <td>-</td> <td><i>Retailer</i></td> <td>5</td> </tr> </tbody> </table> <table border="1"> <thead> <tr> <th colspan="4">Special Discount</th> </tr> </thead> <tbody> <tr> <td>Type of Order</td> <td colspan="2"><i>Web</i></td> <td>-</td> </tr> <tr> <td>Customer Location</td> <td colspan="2"><i>US</i></td> <td>-</td> </tr> <tr> <td>Type of Customer</td> <td><i>Wholesaler</i></td> <td><i>Retailer</i></td> <td>-</td> </tr> <tr> <td>Special Discount %</td> <td>10</td> <td>5</td> <td>0</td> </tr> <tr> <td>F</td> <td>1</td> <td>2</td> <td>3</td> </tr> </tbody> </table> <p><i>Example case: Web, non-US, Retailer -> 0 (rule 3)</i></p>	Special Discount					F	Type of Order	Customer Location	Type of Customer	Special Discount %	1	<i>Web</i>	<i>US</i>	<i>Wholesaler</i>	10	2	<i>Phone</i>	-	-	0	3	-	<i>Non-US</i>	-	0	4	-	-	<i>Retailer</i>	5	Special Discount				Type of Order	<i>Web</i>		-	Customer Location	<i>US</i>		-	Type of Customer	<i>Wholesaler</i>	<i>Retailer</i>	-	Special Discount %	10	5	0	F	1	2	3
Special Discount																																																							
F	Type of Order	Customer Location	Type of Customer	Special Discount %																																																			
1	<i>Web</i>	<i>US</i>	<i>Wholesaler</i>	10																																																			
2	<i>Phone</i>	-	-	0																																																			
3	-	<i>Non-US</i>	-	0																																																			
4	-	-	<i>Retailer</i>	5																																																			
Special Discount																																																							
Type of Order	<i>Web</i>		-																																																				
Customer Location	<i>US</i>		-																																																				
Type of Customer	<i>Wholesaler</i>	<i>Retailer</i>	-																																																				
Special Discount %	10	5	0																																																				
F	1	2	3																																																				
<p>Multiple Hit No order</p>	<table border="1"> <thead> <tr> <th colspan="8">Holidays</th> </tr> </thead> <tbody> <tr> <td>Age</td> <td>-</td> <td><18</td> <td>≥ 60</td> <td>-</td> <td>[18..60]</td> <td>≥ 60</td> <td>-</td> </tr> <tr> <td>Years of Service</td> <td>-</td> <td>-</td> <td>-</td> <td>≥ 30</td> <td>[15..30]</td> <td>-</td> <td>≥ 30</td> </tr> <tr> <td>Holidays</td> <td>22</td> <td>5</td> <td>5</td> <td>5</td> <td>2</td> <td>3</td> <td>3</td> </tr> <tr> <td>C+</td> <td>1</td> <td>2</td> <td>3</td> <td>4</td> <td>5</td> <td>6</td> <td>7</td> </tr> </tbody> </table> <p><i>Example case: Age=58, Service=31 -> Result=sum(22, 5, 3)=30</i></p>	Holidays								Age	-	<18	≥ 60	-	[18..60]	≥ 60	-	Years of Service	-	-	-	≥ 30	[15..30]	-	≥ 30	Holidays	22	5	5	5	2	3	3	C+	1	2	3	4	5	6	7														
Holidays																																																							
Age	-	<18	≥ 60	-	[18..60]	≥ 60	-																																																
Years of Service	-	-	-	≥ 30	[15..30]	-	≥ 30																																																
Holidays	22	5	5	5	2	3	3																																																
C+	1	2	3	4	5	6	7																																																

Multiple Hit Output order	Holidays				
	O	Age	Years of Service	Holidays	
				22, 5, 3, 2	
	1	-	-	22	
	2	>= 60	-	3	
	3	-	>= 30	3	
	4	< 18	-	5	
	5	>= 60	-	5	
	6	-	>= 30	5	
	7	[18..60)	[15..30)	2	
8	[45..60)	< 30	2		
<i>Example case: Age=58, Service=31 -> Result=(22, 5, 3)</i>					
Multiple Hit Rule order	Student Financial Package Eligibility				
	R	Student GPA	Student Extra-Curricular Activities Count	Student National Honor Society Membership	Student Financial Package Eligibility List
	1	> 3.5	>= 4	Yes	20% Scholarship
	2	> 3.0	-	Yes	30% Loan
	3	> 3.0	>= 2	No	20% Work-On-Campus
	4	<= 3.0	-	-	5% Work-On-Campus
<i>Example case: For GPA=3.6, EC Activities=4, NHS Membership -> result = (20% scholarship, 30% loan)</i>					

9 Simple Expression Language (S-FEEL)

DMN 1.1 defines the friendly enough expression language (FEEL) for the purpose of giving standard executable semantics to many kinds of expressions in decision model (see clause 10).

This section defines a simple subset of FEEL, S-FEEL, for the purpose of giving standard executable semantics to decision models that use only simple expressions: in particular, decision models where the decision logic is modeled mostly or only using decision tables

9.1 S-FEEL syntax

The syntax for the S-FEEL expressions used in this section is specified in the EBNF below: it is a subset of the FEEL syntax and the production numbering is from the FEEL EBNF, clause 10.3.1.2.

Grammar rules:

1. expression = simple expression ;
- 4 arithmetic expression =
 - 4.a addition | subtraction |
 - 4.b multiplication | division |
 - 4.c exponentiation |
 - 4.d arithmetic negation ;
- 5 simple expression = arithmetic expression | simple value | comparison ;
- 6 simple expressions = simple expression , { "," , simple expression } ;
- 7 simple positive unary test =
 - 7.a ["<" | "<=" | ">" | ">="] , endpoint |
 - 7.b interval ;
- 8 interval = (open interval start | closed interval start) , endpoint , "." , endpoint , (open interval end | closed interval end) ;
- 9 open interval start = "(" | "[" ;
- 10 closed interval start = "[" ;
- 11 open interval end = ")" | "]" ;
- 12 closed interval end = "]" ;
- 13 simple positive unary tests = simple positive unary test , { "," , simple positive unary test } ;
- 14 simple unary tests =
 - 14.a simple positive unary tests |
 - 14.b "not" , "(" , simple positive unary tests , ")" |
 - 14.c "-";
- 18 endpoint = simple value ;
- 19 simple value = qualified name | simple literal ;
- 20 qualified name = name , { "." , name } ;
- 21 addition = expression , "+" , expression ;

22 subtraction = expression , "-" , expression ;

23 multiplication = expression , "*" , expression ;

24 division = expression , "/" , expression ;

25 exponentiation = expression , "**" , expression ;

26 arithmetic negation = "-" , expression ;

27 name = name start , { name part | additional name symbols } ;

28 name start = name start char , { name part char } ;

29 name part = name part char , { name part char } ;

30 name start char = "?" | [A-Z] | "_" | [a-z] | [\u00-\u0D6] | [\uD8-\uF6] | [\uF8-\u2FF] | [\u370-\u37D] | [\u37F-\u1FFF] | [\u200C-\u200D] | [\u2070-\u218F] | [\u2C00-\u2FEF] | [\u3001-\uD7FF] | [\uF900-\uFDCF] | [\uFDF0-\uFFFD] | [\u10000-\uEFFFE] ;

31 name part char = name start char | digit | \uB7 | [\u0300-\u036F] | [\u203F-\u2040] ;

32 additional name symbols = "." | "/" | "-" | "?" | "+" | "*" ;

33 simple literal = numeric literal | string literal | Boolean literal | date time literal ;

34 string literal = "" , { character – ("" | vertical space) } , "" ;

35 Boolean literal = "true" | "false" ;

36 numeric literal = ["-"] , (digits , ["." , digits] | "." , digits) ;

37 digit = [0-9] ;

38 digits = digit , {digit} ;

39 date time literal = ("date" | "time" | "duration") , "(" , string literal , ")" ;

51 comparison =

51.a expression , ("=" | "!=" | "<" | "<=" | ">" | ">=") , expression ;

9.2 S-FEEL data types

S-FEEL supports all FEEL data types: *number*, *string*, *boolean*, *days and time duration*, *years and months duration*, *time* and *date*, although with a simplified definition for some of them.

S-FEEL *number* has the same literal and values spaces as the XML Schema decimal datatype. Implementations are allowed to limit precision to 34 decimal digits and to round toward the nearest neighbor with ties favoring the even neighbor. Notice that “*precision is not reflected in this value space: the number 2.0 is not distinct from the number 2.00*” [XML Schema]. Notice, also, that this value space is totally ordered. The definition of S-FEEL *number* is a simplification over the definition of FEEL *number*.

S-FEEL supports FEEL *string* and FEEL *Boolean*: FEEL *string* has the same literal and values spaces as the Java String and XML Schema string datatypes. FEEL *boolean* has the same literal and values spaces as the Java Boolean and XML Schema Boolean datatypes.

S-FEEL supports the FEEL *time* data type. The lexical and value spaces of FEEL *time* are the literal and value spaces of the [XML Schema](#) time datatype. Notice that, “*since the lexical representation allows an optional time zone indicator, time values are partially ordered because it may not be able to determine the order of two values one of which has a time zone and the other does not. Pairs of time values with or without time zone indicators are totally ordered*” [XSD].

S-FEEL does not support FEEL date and time. However, it supports the *date* type, which is like FEEL *date and time* with hour, minute, and second required to be absent. The lexical and value spaces of FEEL *date* are the literal and value spaces of the [XML Schema](#) date datatype.

S-FEEL supports the FEEL *days and time duration* and *years and months duration* datatypes. FEEL *days and time duration* and *years and months duration* have the same literal and value spaces as the [XPath Data Model](#) `dayTimeDuration` and `yearMonthDuration` datatypes, respectively. That is, FEEL *days and time duration* is derived from the XML Schema duration datatype by restricting its lexical representation to contain only the days, hours, minutes and seconds components, and FEEL *years and months duration* is derived from the XML Schema duration datatype by restricting its lexical representation to contain only the year and month components.

The FEEL data types are specified in details in clause 10.3.2.2.

9.3 S-FEEL semantics

S-FEEL contains only a limited set of basic features that are common to most expression and programming languages, and on the semantics of which most expression and programming languages agree.

The semantics of S-FEEL expressions are defined in this section, in terms of the semantics of the XML Schema datatypes and the XQuery 1.0 and XPath 2.0 Data Model datatypes, and in terms of the corresponding functions and operators defined by XQuery 1.0 and XPath 2.0 Functions and Operators (prefixed by “op:” below). A complete stand-alone specification of the semantics is to be found in clause 10.3.2, as part of the definition of FEEL. Within the scope of S-FEEL, the two definitions are equivalent and equally normative.

Arithmetic addition and subtraction (grammar rule 4a) have the same semantics as:

- `op:numeric-add` and `op:numeric-subtract`, when its two operands are numbers;
- `op:add-yearMonthDurations` and `op:subtract-yearMonthDurations`, when the two operands are years and months durations;
- `op:add-dayTimeDuration` and `subtract:dayTimeDurations`, when the two operands are days and time durations;
- `op:add-yearMonthDuration-to-date` and `op:subtract-yearMonthDuration-from-date`, when the first operand is a years and months duration and the second operand is a date;
- `op:add-dayTimeDuration-to-date` and `op:subtract-dayTimeDuration-from-date`, when the first operand is a days and time duration and the second operand is a date;
- `op:add-dayTimeDuration-to-time` and `op:subtract-dayTimeDuration-from-time`, when the first operand is a days and time duration and the second operand is a time.

In addition, arithmetic subtraction has the semantics of `op:subtract-dates` or `op:subtract-times`, when the two operands are dates or times, respectively.

Arithmetic addition and subtraction are not defined in other cases.

Arithmetic multiplication and division (grammar rule 4b) have the same semantics as defined for `op:numeric-multiply` and `op:numeric-divide`, respectively, when the two operands are numbers. They are not defined otherwise. Arithmetic exponentiation (grammar rule 4c) is defined as the result of raising the first operand to the power of the second operand, when the two operands are numbers. It is not defined in other cases.

Arithmetic negation (grammar rule 4d) is defined only when its operand is a number: in that case, its semantics is according to the specification of `op:numeric-unary-minus`.

Comparison operators (grammar rule 7.a) between numbers are defined according to the specification of `op:numeric-equal`, `op:numeric-less-than` and `op:numeric-greater-than`, comparisons between dates are defined according to the specification of `op:date-equal`, `op:date-less-than` and `op:date-greater-than`; comparisons between times are defined according to the specification of `op:time-equal`, `op:time-less-than` and `op:time-greater-than`; comparisons between years and months durations are defined according to the specification of `op:duration-equal`, `op:yearMonthDuration-less-than` and `op:year-MonthDuration-greater-than`; comparisons between days and time durations are defined according to the specification of `op:duration-equal`, `op:dayTimeDuration-less-than` and `op:dayTimeDuration-greater-than`.

String and Booleans can only be compared for equality: the semantics of strings and Booleans equality is as defined in the specification of `fn:codepoint-equal` and `op:Boolean-equal`, respectively.

Comparison operators are defined only when the two operands have the same type, except for years and months duration and days and time duration, which can be compared for equality. Notice, however, that “*with the exception of the zero-length duration, no instance of xs:dayTimeDuration can ever be equal to an instance of xs:yearMonthDuration.*” [XFO].

Given an expression *o* to be tested and two endpoint *e1* and *e2*:

- is in the interval (*e1*..*e2*), also notated]*e1*..*e2*[, if and only if $o > e1$ and $o < e2$
- is in the interval (*e1*..*e2*], also notated]*e1*..*e2*], if and only if $o > e1$ and $o \leq e2$
- is in the interval [*e1*..*e2*] if and only if $o \geq e1$ and $o \leq e2$
- is in the interval [*e1*..*e2*), also notated [*e1*..*e2*[, if and only if $o \geq e1$ and $o < e2$

An expression to be tested satisfies an instance of simple unary tests (grammar rule 14) if and only if, either the expression is a list and the expression satisfies at least one simple unitary test in the list, or the simple unitary tests is “-”.

9.4 Use of S-FEEL expressions

This section summarizes which kinds of S-FEEL expressions are allowed in which role, when the expression language is S-FEEL.

9.4.1 Item definitions

The expression that defines an **allowed value** SHALL be an instance of *simple unary tests* (grammar rule 14), where only the values in the defined or referenced type that satisfy the test are allowed values.

9.4.2 Invocations

In the bindings of an invocation, the **binding formula** SHALL be a *simple expression* (grammar rule 5).

9.4.3 Decision tables

Each **input expression** SHALL be a *simple expression* (grammar rule 5).

Each list of **input values** SHALL be an instance of *simple unary tests* (grammar rule 14).

Each list of output values SHALL be an instance of *simple unary tests* (grammar rule 14).

Each **input entry** SHALL be an instance of *simple unary tests* (grammar rule 14).

Each **output entry** SHALL be a *simple expression* (grammar rule 5).

10 Expression Language (FEEL)

10.1 Introduction

In **DMN**, all decision logic is represented as *boxed expressions*. Clause 7.2 introduced the concept of the boxed expression and defined two simple kinds: boxed literal expressions and boxed invocations. Clause 8 defined decision tables, a very important kind of boxed expression. This section completes the graphical notation for decision logic, by defining other kinds of boxed expressions.

The expressions 'in the boxes' are FEEL expressions. FEEL stands for Friendly Enough Expression Language and it has the following features:

- Side-effect free
- Simple data model with numbers, dates, strings, lists, and contexts
- Simple syntax designed for a wide audience
- Three-valued logic (**true**, **false**, **null**) based on SQL and PMML

This section also completely specifies the syntax and semantics of FEEL. The syntax is specified as a grammar (10.3.1). The subset of the syntax intended to be rendered graphically as a boxed expression is also specified as a meta-model (10.5).

FEEL has two roles in **DMN**:

1. As a textual notation in the boxes of boxed expressions such as decision tables,
2. As a slightly larger language to represent the logic of expressions and DRGs for the main purpose of composing the semantics in a simple and uniform way

10.2 Notation

10.2.1 Boxed Expressions

This section builds on the generic notation for decision logic and boxed expressions defined in clause 7.2.

We define a graphical notation for decision logic called **boxed expressions**. This notation serves to decompose the decision logic model into small pieces that can be associated with DRG artifacts. The DRG plus the boxed expressions form a complete, mostly graphical language that completely specifies Decision Models.

A **boxed expression** is either

- a **decision table**,
- a **boxed FEEL expression**,
- a **boxed invocation**,
- a **boxed context**,
- a **boxed list**,
- a **relation**, or
- a **boxed function**.

Boxed expressions are defined recursively, *i.e.* boxed expressions can contain other boxed expressions. The top-level boxed expression corresponds to the decision logic of a single DRG artifact. This boxed expression **SHALL** have a name box that contains the name of the DRG artifact. The name box may be attached in a single box on top, as shown in Figure 52:

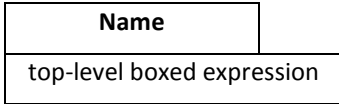

Figure 52: Boxed expression

Alternatively, the name box and expression box can be separated by white space and connected on the left side with a line, as shown in Figure 53:

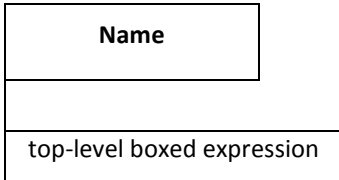

Figure 53: Boxed expression with separated name and expression boxes

Graphical tools are expected to support appropriate graphical links, for example, clicking on a decision shape opens a decision table.

10.2.1.1 Decision Tables

The executable decision tables defined here use the same notation as the decision tables defined in Clause 8. Their execution semantics is defined in clause 10.3.2.8.

10.2.1.2 Boxed FEEL expression

A **boxed FEEL expression** is any FEEL expression e , as defined by the FEEL grammar (clause 10.3.1), in a table cell, as shown in Figure 54:



Figure 54: Boxed FEEL expression

The meaning of a boxed expression containing e is **FEEL**(e , s), where s is the scope. The scope includes the context derived from the containing DRD as described in 10.4, and any boxed contexts containing e .

It is usually good practice to make e relatively simple, and compose small boxed expressions into larger boxed expressions.

10.2.1.3 Boxed Invocation

The syntax for boxed invocation is described in clause 7.2.3. This syntax may be used to invoke any function (e.g. business knowledge model, FEEL built-in function, boxed function definition).

The box labeled 'invoked business knowledge model' can be any boxed expression whose value is a function, as shown in Figure 55:

Name	
function-valued expression	
parameter 1	binding expression 1
parameter 2	binding expression 2
...	
parameter <i>n</i>	binding expression <i>n</i>

Figure 55: Boxed invocation

The boxed syntax maps to the textual syntax defined by grammar rules 40, 41, 42, 43. Boxed invocation uses named parameters. Positional invocation can be achieved using a boxed expression containing a textual positional invocation.

The boxed syntax requires at least one parameter. A parameterless function must be invoked using the textual syntax, e.g. as shown in Figure 56.

function-valued expression()

Figure 56: Parameterless function

Formally, the meaning of a boxed invocation is given by the semantics of the equivalent textual invocation, *e.g.*, **function-valued expression**(parameter₁: **binding expression**₁, parameter₂: **binding expression**₂, ...).

10.2.1.4 Boxed Context

A **boxed context** is a collection of *n* (name, value) pairs with an optional result value. Each pair is called a context entry. Context entries may be separated by whitespace and connected with a line on the left (top). The intent is that all the entries of a context should be easily identified by looking down the left edge of a vertical context or across the top edge of a horizontal context. Cells SHALL be arranged in one of the following ways (see Figure 57, Figure 58):

Name 1	Value 1
Name 2	Value 2
Name <i>n</i>	Value <i>n</i>
Result	

Figure 57: Vertical context

Name 1	Name 2	Name <i>n</i>		Result
Value 1	Value 2	Value <i>n</i>		

Figure 58: Horizontal context

The context entries in a context are often used to decompose a complex expression into simpler expressions, each with a name. These context entries may be thought of as intermediate results. For example, contexts without a final Result box are useful for representing case data (see Figure 59).

Applicant Data		
Age	51	
MaritalStatus	"M"	
EmploymentStatus	"EMPLOYED"	
ExistingCustomer	false	
Monthly	Income	10000.00
	Repayments	2500.00
	Expenses	3000.00

Figure 59: Use of context entries

Contexts with a final result box are useful for representing calculations (see Figure 60).

Eligibility	
Age	Applicant. Age
Monthly Income	Applicant. Monthly. Income
Pre-Bureau Risk Category	Affordability. Pre-Bureau Risk Category
Installment Affordable	Affordability. Installment Affordable
if Pre-Bureau Risk Category = "DECLINE" or Installment Affordable = false or Age < 18 or Monthly Income < 100 then "INELIGIBLE" else "ELIGIBLE"	

Figure 60: Use of final result box

When decision tables are (non-result) context entries, the output cell can be used to name the entry, thus saving space. Any format decision table can be used in a vertical context. A jagged right edge is allowed. Whitespace between context entries may be helpful. See Figure 61.

Name 1	Value 1
	Name 2
Name <i>n</i>	Value <i>n</i>
Result	

Figure 61: Vertical context with decision table entry

Color is suggested.

The names SHALL be legal FEEL names. The values and optional result are boxed expressions.

Boxed contexts may have a decision table as the result, and use the named context entries to compute the inputs, and give them names. For example (see Figure 62):

Post-Bureau Risk Category				
Existing Customer		Applicant. ExistingCustomer		
Credit Score		Report. CreditScore		
Application Risk Score		Affordability Model(Applicant, Product). Application Risk Score		
U	Existing Customer	Application Risk Score	Credit Score	Post-Bureau Risk Category
1	true	<=120	<590	"HIGH"
2			[590..610]	"MEDIUM"
3			>610	"LOW"
4		>120	<600	"HIGH"
5			[600..625]	"MEDIUM"
6			>625	"LOW"
7	false	<=100	<580	"HIGH"
8			[580..600]	"MEDIUM"
9			>600	"LOW"
10		>100	<590	"HIGH"
11			[590..615]	"MEDIUM"
12			>615	"LOW"

Figure 62: Use of boxed expressions with a decision table

Formally, the meaning of a boxed context is { **"Name 1": Value 1, "Name 2": Value 2, ..., "Name n": Value n** } if no Result is specified. Otherwise, the meaning is { **"Name 1": Value 1, "Name 2": Value 2, ..., "Name n": Value n, "result": Result** }.result. Recall that the bold face indicates elements in the FEEL Semantic Domain. The scope includes the context derived from the containing DRG as described in 10.4.

10.2.1.5 Boxed List

A **boxed list** is a list of n items. Cells SHALL be arranged in one of the following ways (see Figure 63, Figure 64):

Item 1
Item 2
Item <i>n</i>

Figure 63: Vertical list

Item 1, Item 2, Item <i>n</i>

Figure 64: Horizontal list

Line styles are normative. The items are boxed expressions. Formally, the meaning of a boxed list is just the meaning of the list, i.e. [**Item 1, Item 2, ..., Item *n***]. The scope includes the context derived from the containing DRG as described in 10.4.

10.2.1.6 Relation

A vertical list of homogeneous horizontal contexts (with no result cells) can be displayed with the names appearing just once at the top of the list, like a relational table, as shown in Figure 65:

Name 1	Name 2	Name <i>n</i>
Value 1a	Value 2a	Value <i>na</i>
Value 1b	Value 2b	Value <i>nb</i>
Value 1 <i>m</i>	Value 2 <i>m</i>	Value <i>nm</i>

Figure 65: Relation

10.2.1.7 Boxed Function

A Boxed Function Definition is the notation for parameterized boxed expressions.

The boxed expression associated with a Business Knowledge Model SHALL be a boxed function definition or a decision table whose input expressions are assumed to be the parameter names.

A boxed function has 3 cells:

1. Kind, containing the initial letter of one of the following:
 - FEEL
 - PMML
 - Java

The Kind box can be omitted for Feel functions, including decision tables.

2. Parameters: 0 or more comma-separated names, in parentheses

3. Body: a boxed expression

The 3 cells SHALL be arranged as shown in Figure 66:

K	(Parameter1, Parameter2, ...)
Body	

Figure 66: Boxed function definition

For FEEL functions, denoted by Kind FEEL or by omission of Kind, the Body SHALL be a FEEL expression that references the parameters. For externally defined functions denoted by Kind JAVA, the Body SHALL be a context as described in 10.3.2.11.2 and the form of the mapping information SHALL be the *java* form. For externally defined functions denoted by Kind PMML, the Body SHALL be a context as described in 10.3.2.11.2 and the form of the mapping information SHALL be the *pmml* form.

Formally, the meaning of a boxed function is just the meaning of the function, *i.e.*, FEEL(*function(Parameter1, Parameter2, ...) Body*) if the Kind is FEEL, and FEEL(*function(Parameter1, Parameter2, ...) external Body*) otherwise. The scope includes the context derived from the containing DRG as described in 10.4.

10.2.2 FEEL

A subset of FEEL, defined in the next section, serves as the notation "in the boxes" of boxed expressions. A FEEL object is a number, a string, a date, a time, a duration, a function, a context, or a list of FEEL objects (including nested lists).

Note: A JSON object is a number, a string, a context (JSON calls them maps) or a list of JSON objects. So FEEL is an extension of JSON in this regard. In addition, FEEL provides friendlier syntax for literal values, and does not require context keys to be quoted.

Here we give a "feel" for the language by starting with some simple examples.

10.2.2.1 Comparison of ranges

Ranges and lists of ranges appear in decision table input entry, input value, and output value cells. In the examples in Table 32, this portion of the syntax is shown underlined. Strings, dates, times, and durations also may be compared, using typographical literals defined in section 7.2.2.1.

Table 32: FEEL range comparisons

FEEL Expression	Value
5 in (<u><=5</u>)	true
5 in ((<u>5..10</u>])	false
5 in ([<u>5..10</u>])	true
5 in (<u>4, 5, 6</u>)	true
5 in (<u><5, >5</u>)	false

<i>2012-12-31</i> in (<i>(2012-12-25..2013-02-14)</i>)	true
---	------

10.2.2.2 Numbers

FEEL numbers and calculations are exemplified in Table 33.

Table 33: FEEL numbers and calculations

FEEL Expression	Value
decimal(1, 2)	1.00
.25 + .2	0.45
.10 * 30.00	3.0000
1 + 3/2*2 - 2**3	-4.0
1/3	0.33333333333333333333333333333333
decimal(1/3, 2)	0.33
1 = 1.000	true
1.01/2	0.505
decimal(0.505, 2)	0.50
decimal(0.515, 2)	0.52
1.0*10**3	1000.0

10.3 Full FEEL Syntax and Semantics

Clause 9 introduced a subset of FEEL sufficient to support decision tables for Conformance Level 2 (see clause 2). The full **DMN** friendly-enough expression language (FEEL) required for Conformance Level 3 is specified here. FEEL is a simple language with inspiration drawn from Java, JavaScript, XPath, SQL, PMML, Lisp, and many others.

The syntax is defined using grammar rules that show how complex expressions are composed of simpler expressions. Likewise, the semantic rules show how the meaning of a complex expression is composed from the meaning of constituent simpler expressions.

DMN completely defines the meaning of FEEL expressions that do not invoke externally-defined functions. There are no implementation-defined semantics. FEEL expressions (that do not invoke externally-defined functions) have no side-effects and have the same interpretation in every conformant implementation. Externally-defined functions **SHOULD** be deterministic and side-effect free.

10.3.1 Syntax

FEEL syntax is defined as grammar here and equivalently as a UML Class diagram in the meta-model (10.5).

10.3.1.1 Grammar notation

The grammar rules use the [ISO EBNF](#) notation. Each rule defines a non-terminal symbol S in terms of some other symbols S_1, S_2, \dots . Symbols may contain spaces. The following table summarizes the EBNF notation.

Table 34: EBNF notation

Example	Meaning
$S = S_1 ;$	Symbol S is defined in terms of symbol S_1
$S_1 S_2$	Either S_1 or S_2
S_1, S_2	S_1 followed by S_2
$[S_1]$	S_1 occurring 0 or 1 time
$\{S_1\}$	S_1 repeated 0 or more times
$k * S_1$	S_1 repeated k times
"and"	literal terminal symbol

We extend the ISO notation with character ranges for brevity, as follows:

A character range has the following EBNF syntax:

```

character range = "[" low character "-" high character "]" ;
low character = unicode character ;
high character = unicode character ;
unicode character = simple character | code point ;
code point = "\u", hexadecimal digit, 4 * [hexadecimal digit] ;
hexadecimal digit = "0" | "1" | "2" | "3" | "4" | "5" | "6" | "7" | "8" | "9" |
                    "a" | "A" | "b" | "B" | "c" | "C" | "d" | "D" | "e" | "E" | "f" | "F" ;

```

A simple character is a single Unicode character, e.g. a, 1, \$, etc. Alternatively, a character may be specified by its hexadecimal code point value, prefixed with `\u`.

Every Unicode character has a numeric code point value. The low character in a range must have numeric value less than the numeric value of the high character.

For example, hexadecimal digit can be described more succinctly using character ranges as follows:

```
hexadecimal digit = [0-9] | [a-f] | [A-F] ;
```

Note that the character range that includes all Unicode characters is `[\u0000-\u10FFFF]`.

10.3.1.2 Grammar rules

The complete FEEL grammar is specified below. Grammar rules are numbered, and in some cases alternatives are lettered, for later reference. Boxed expression syntax (rule 55) is used to give execution semantics to boxed expressions.

1. expression =

- a. textual expression |
 - b. boxed expression ;
2. textual expression =
- a. function definition | for expression | if expression | quantified expression |
 - b. disjunction |
 - c. conjunction |
 - d. comparison |
 - e. arithmetic expression |
 - f. instance of |
 - g. path expression |
 - h. filter expression | function invocation |
 - i. literal | simple positive unary test | name | "(" , textual expression , ")" ;
3. textual expressions = textual expression , { " , " , textual expression } ;
4. arithmetic expression =
- a. addition | subtraction |
 - b. multiplication | division |
 - c. exponentiation |
 - d. arithmetic negation ;
5. simple expression = arithmetic expression | simple value ;
6. simple expressions = simple expression , { " , " , simple expression } ;
7. simple positive unary test =
- a. ["<" | "<=" | ">" | ">="] , endpoint |
 - b. interval ;
8. interval = (open interval start | closed interval start) , endpoint , ".." , endpoint , (open interval end | closed interval end) ;
9. open interval start = "(" | "[" ;
10. closed interval start = "[" ;
11. open interval end = ")" | "]" ;
12. closed interval end = "]" ;
13. simple positive unary tests = simple positive unary test , { " , " , simple positive unary test } ;
14. simple unary tests =
- a. simple positive unary tests |
 - b. "not" , "(" , simple positive unary tests , ")" |
 - c. "-";
15. positive unary test = simple positive unary test | "null" ;
16. positive unary tests = positive unary test , { " , " , positive unary test } ;
17. unary tests =

- a. positive unary tests |
 - b. "not", "(", positive unary tests, ")" |
 - c. "-"
18. endpoint = simple value ;
 19. simple value = qualified name | simple literal ;
 20. qualified name = name , { ".", name } ;
 21. addition = expression , "+" , expression ;
 22. subtraction = expression , "-" , expression ;
 23. multiplication = expression , "*" , expression ;
 24. division = expression , "/" , expression ;
 25. exponentiation = expression , "**" , expression ;
 26. arithmetic negation = "-" , expression ;
 27. name = name start , { name part | additional name symbols } ;
 28. name start = name start char , { name part char } ;
 29. name part = name part char , { name part char } ;
 30. name start char = "?" | [A-Z] | "_" | [a-z] | [\uC0-\uD6] | [\uD8-\uF6] | [\uF8-\u2FF] | [\u370-\u37D] | [\u37F-\u1FFF] | [\u200C-\u200D] | [\u2070-\u218F] | [\u2C00-\u2FEF] | [\u3001-\uD7FF] | [\uF900-\uFDCF] | [\uFDF0-\uFFFF] | [\u10000-\uEFFFF] ;
 31. name part char = name start char | digit | \uB7 | [\u0300-\u036F] | [\u203F-\u2040] ;
 32. additional name symbols = "." | "/" | "-" | "'" | "+" | "*" ;
 33. literal = simple literal | "null" ;
 34. simple literal = numeric literal | string literal | Boolean literal | date time literal ;
 35. string literal = "" , { character – ("" | vertical space) } , "" ;
 36. Boolean literal = "true" | "false" ;
 37. numeric literal = ["-"] , (digits , ["." , digits] | "." , digits) ;
 38. digit = [0-9] ;
 39. digits = digit , {digit} ;
 40. function invocation = expression , parameters ;
 41. parameters = "(" , (named parameters | positional parameters) , ")" ;
 42. named parameters = parameter name , ":" , expression , { " , " , parameter name , ":" , expression } ;
 43. parameter name = name ;
 44. positional parameters = [expression , { " , " , expression }] ;
 45. path expression = expression , "." , name ;
 46. for expression = "for" , name , "in" , expression { " , " , name , "in" , expression } , "return" , expression ;
 47. if expression = "if" , expression , "then" , expression , "else" expression ;
 48. quantified expression = ("some" | "every") , name , "in" , expression , { name , "in" , expression } , "satisfies" , expression ;

49. disjunction = expression , "or" , expression ;
50. conjunction = expression , "and" , expression ;
51. comparison =
 - a. expression , ("=" | "!=" | "<" | "<=" | ">" | ">=") , expression |
 - b. expression , "between" , expression , "and" , expression |
 - c. expression , "in" , positive unary test ;
 - d. expression , "in" , " (" , positive unary tests , ")" ;
52. filter expression = expression , "[" , expression , "]" ;
53. instance of = expression , "instance" , "of" , type ;
54. type = qualified name ;
55. boxed expression = list | function definition | context ;
56. list = "[" [expression , { "," , expression }] , "]" ;
57. function definition = "function" , "(" , [formal parameter { "," , formal parameter }] , ")" , ["external"] , expression ;
58. formal parameter = parameter name ;
59. context = "{" , [context entry , { "," , context entry }] , "}" ;
60. context entry = key , ":" , expression ;
61. key = name | string literal ;
62. date time literal = ("date" | "time" | "date and time" | "duration") , "(" , string literal , ")" ;

Additional syntax rules:

- Operator precedence is given by the order of the alternatives in grammar rules 1, 2 and 4, in order from lowest to highest. *E.g.*, (boxed) invocation has higher precedence than multiplication, multiplication has higher precedence than addition, and addition has higher precedence than comparison. Addition and subtraction have equal precedence, and like all FEEL infix binary operators, are left associative.
- A name may contain spaces but may not contain a sequence of 2 or more spaces.
- A name start (grammar rule 28) SHALL NOT be a language keyword. (Language keywords are enclosed in double quotes in the grammar rules, for example, "and", "or", "true", "false".)
- A name part (grammar rule 29) MAY be a language keyword.
- Java-style comments can be used, *i.e.* `/**` to end of line and `/* ... */`.

10.3.1.3 Literals, data types, built-in functions

FEEL supports literal syntax for numbers, strings, booleans, and *null*. (See grammar rules, clause 10.3.1.2). Literals can be mapped directly to values in the FEEL semantic domain (clause 10.3.2.1).

FEEL supports the following datatypes:

- number
- string
- boolean
- days and time duration

- years and months duration
- time
- date and time

Duration and date/time datatypes have no literal syntax. They must be constructed from a string representation using a built-in function (10.3.4.1).

10.3.1.4 Contexts, Lists, Qualified Names, and Context Lists

A context is a map of key-value pairs called context entries, and is written using curly braces to delimit the context, commas to separate the entries, and a colon to separate key and value (grammar rule 59). The key can be a string or a name. The value is an expression.

A list is written using square brackets to delimit the list, and commas to separate the list items (grammar rule 56). A singleton list is equal to its single item, *i.e.*, $[e]=e$ for all FEEL expressions e .

Contexts and lists can reference other contexts and lists, giving rise to a directed acyclic graph. Naming is path based. The *qualified name* (QN) of a context entry is of the form $N_1.N_2 \dots N_n$ where N_i is the name of an in-scope context.

Nested lists encountered in the interpretation of $N_1.N_2 \dots N_n$ are preserved. *E.g.*,

$$\begin{aligned} & [\{a: [\{b: 1\}, \{b: [2.1, 2.2]\}]\}, \{a: [\{b: 3\}, \{b: 4\}, \{b: 5\}]\}].a.b = \\ & [[\{b: 1\}, \{b: [2.1, 2.2]\}], [\{b: 3\}, \{b: 4\}, \{b: 5\}]].b = \\ & [[1, [2.1, 2.1]], [3, 4, 5]] \end{aligned}$$

Nested lists can be flattened using the *flatten()* built-in function (10.3.4).

10.3.1.5 Ambiguity

Names of context entries and function parameters can contain commonly used characters such as space and apostrophe (but cannot contain a colon or comma (':' or ',')). This naming freedom makes FEEL's syntax ambiguous. Ambiguity is resolved using the scope. Names are matched from left to right against the names in-scope, and the longest match is preferred. In the case where the longest match is not desired, parenthesis or other punctuation (that is not allowed in a name) can be used to disambiguate a FEEL expression. For example, to subtract b from a if 'a-b' is the name of an in-scope context entry, one could write

$$(a) - (b)$$

10.3.2 Semantics

FEEL semantics is specified by mapping syntax fragments to values in the FEEL semantic domain. Literals (clause 10.3.1.3) can be mapped directly. Expressions composed of literals are mapped to values in the semantic domain using simple logical and arithmetic operations on the mapped literal values. In general, the semantics of any FEEL expression are composed from the semantics of its sub-expressions.

10.3.2.1 Semantic Domain

The FEEL semantic domain **D** consists of an infinite number of values of the following *kinds*: functions, lists, contexts, ranges, datatypes, and the distinguished value **null**. Each kind is disjoint (e.g. a value cannot be both a number and a list).

A function is a lambda expression with lexical closure or is externally defined by Java or PMML. A list is an ordered collection of domain elements, and a context is a partially ordered collection of (string, value) pairs called context entries.

We use *italics* to denote syntactic elements and **boldface** to denote semantic elements. For example,

FEEL(*[1+1, 2+2]*) is **[2, 4]**

Note that we use bold **[]** to denote a list in the FEEL semantic domain, and bold numbers **2, 4** to denote those decimal values in the FEEL semantic domain.

10.3.2.2 Equality, Identity and Equivalence

The semantics of equality are specified in the semantic mappings in clause 10.3.2.12. In general, the values to be compared must be of the same kind, for example, both numbers, to obtain a non-null result.

Identity simply compares whether two objects in the semantic domain are the same object. We denote the test for identity using infix **is**, and its negation using infix **is not**. For example, $\text{FEEL}("1" = 1)$ **is null**. Note that **is** never results in **null**.

Every FEEL expression e in scope s can be mapped to an element e in the FEEL semantic domain. This mapping defines the meaning of e in s . The mapping may be written e **is** $\text{FEEL}(e,s)$. Two FEEL expressions e_1 and e_2 are equivalent in scope s if and only if $\text{FEEL}(e_1,s)$ **is** $\text{FEEL}(e_2,s)$. When s is understood from context (or not important), we may abbreviate the equivalence as e_1 **is** e_2 . Sometimes, when sure that e_1 and e_2 are comparable and not null, we may write $e_1 = e_2$.

10.3.2.3 Semantics of literals and datatypes

FEEL datatypes are described in the following sub-sections. The meaning of the datatypes includes

1. a mapping from a literal form (which in some cases is a string) to a value in the semantic domain
2. a precise definition of the set of semantic domain values belonging to the datatype, and the operations on them.

Each datatype describes a (possibly infinite) set of values. The sets for the datatypes defined below are disjoint.

We use *italics* to indicate a literal and **boldface** to indicate a value in the semantic domain.

10.3.2.3.1 number

FEEL Numbers are based on [IEEE 754-2008](#) Decimal128 format, with 34 decimal digits of precision and rounding toward the nearest neighbor with ties favoring the even neighbor. Numbers are a restriction of the XML Schema type [precisionDecimal](#), and are equivalent to Java [BigDecimal](#) with [MathContext](#) DECIMAL128.

Grammar rule 37 defines literal numbers. Literals consist of base 10 digits and an optional decimal point. $-\text{INF}$, $+\text{INF}$, and NaN literals are not supported. There is no distinction between

-0 and 0 . The *number(from, grouping separator, decimal separator)* built-in function supports a richer literal format. *E.g.* $\text{FEEL}(\text{number}("1.000.000,01", ".", ",")) = \mathbf{1000000.01}$.

FEEL does not support a literal scientific notation. *E.g.*, $1.2\text{e}3$ is not valid FEEL syntax. Use $1.2*10**3$ instead.

A FEEL number is represented in the semantic domain as a pair of integers (\mathbf{p},\mathbf{s}) such that \mathbf{p} is a signed 34 digit integer carrying the precision information, and \mathbf{s} is the scale, in the range $[-6111..6176]$. Each such pair represents the number $\mathbf{p}/10^{\mathbf{s}}$. To indicate the numeric value, we write $\mathbf{value}(\mathbf{p},\mathbf{s})$. *E.g.* $\mathbf{value}(\mathbf{100},\mathbf{2}) = \mathbf{1}$. If precision is not of concern, we may write the value as simply $\mathbf{1}$. Note that many different pairs have the same value. For example, $\mathbf{value}(\mathbf{1},\mathbf{0}) = \mathbf{value}(\mathbf{10},\mathbf{1}) = \mathbf{value}(\mathbf{100},\mathbf{2})$.

There is no value for `notANumber`, `positiveInfinity`, or `negativeInfinity`. Use **null** instead.

10.3.2.3.2 string

Grammar rule 35 defines literal strings as a double-quoted sequence of characters, *e.g.* `"abc"`.

The literal string `"abc"` is mapped to the semantic domain as a sequence of three Unicode characters **a**, **b**, and **c**, written `"abc"`.

10.3.2.3.3 boolean

The Boolean literals are given by grammar rule 36. The values in the semantic domain are **true** and **false**.

10.3.2.3.4 time

FEEL does not have time literals, although we use boldface time literals to represent values in the semantic domain. Times can be expressed using a string literal and the *time()* built-in function. (See 10.3.4.1.)

A time in the semantic domain is a value of the [XML Schema](#) time datatype. It can be represented by a sequence of numbers for the hour, minute, second, and an optional time offset from Universal Coordinated Time (UTC). If a time offset is specified, including time offset = 00:00, the time value has a UTC form and is comparable to all time values that have UTC forms. If no time offset is specified, the time is interpreted as a local time of day at some location, whose relationship to UTC time is dependent on time zone rules for that location, and may vary from day to day. A local time of day value is only sometimes comparable to UTC time values, as described in [XML Schema](#) Part 2 Datatypes.

A time **t** can also be represented as the number of seconds since midnight. We write this as **value_t(t)**. *E.g.*, **value_t(01:01:01) = 3661**.

The **value_t** function is one-to-one, but its range is restricted to [0..86400]. So, it has an inverse function **value_t⁻¹(x)** that returns: the corresponding time value for x, if x is in [0..86400]; and **value_t⁻¹(y)**, where $y = x - \text{floor}(x/86400) * 86400$, if x is not in [0..86400].

Note: That is, **value_t⁻¹(x)** is always actually applied to x modulo 86400. For example, **value_t⁻¹(3600)** will return the time of day that is “T01:00:00”, **value_t⁻¹(90000)** will also return “T01:00:00”, and **value_t⁻¹(-3600)** will return the time of day that is “T23:00:00”, treating -3600 seconds as one hour *before* midnight.

10.3.2.3.5 date

FEEL does not have date literals, although it uses boldface date literals to represent values in the semantic domain. Dates can be expressed using a string literal and the `date()` built-in function (see 10.3.4.1). A date in the semantic domain is a sequence of numbers for the year, month, day of month. The year must be in the range [-999,999,999..999,999,999].

Where necessary, including the **value_{dt}** function (see 10.3.2.x.6), a date value is considered to be equivalent to a date time value in which the time of day is UTC midnight (00:00:00).

10.3.2.3.6 date-time

FEEL does not have date-time literals, although it uses boldface date-time literals to represent values in the semantic domain. Date-times can be expressed using a string literal and the `date and time()` built-in function (see 10.3.4.1).

A date and time in the semantic domain is a sequence of numbers for the year, month, day, hour, minute, second, and optional time offset from Universal Coordinated Time (UTC). The year must be in the range [-999,999,999..999,999,999]. If there is an associated time offset, including 00:00, the date-time value has a UTC form and is comparable to all other date-time values that have UTC forms. If there is no associated time offset, the time is taken to be a local time of day at some location, according to the time zone rules for that location. When the time zone is specified, e.g., using the IANA tz form (see 10.3.4.1), the date-time value may be converted to a UTC form using the time zone rules for that location, if applicable.

Note: projecting timezone rules into the future may only be safe for near-term date-time values.

A date and time **d** that has a UTC form can be represented as a number of seconds since a reference date and time (called the epoch). We write **value_{dt}(d)** to represent the number of seconds between **d** and the epoch. The **value_{dt}** function is one-to-one and so it has an inverse function **value_{dt}⁻¹**. *E.g.*, **value_{dt}⁻¹(value_{dt}(d)) = d**. **value_{dt}⁻¹** returns **null** rather than a date with a year outside the legal range.

10.3.2.3.7 days and time duration

FEEL does not have duration literals although we use boldface duration literals to represent values in the semantic domain.. Durations can be expressed using a string literal and the `duration()` built-in function. The literal format of the characters within the quotes of the string literal is defined by the lexical space of the [XPath Data Model](#) `dayTimeDuration` datatype. A days and time duration in the semantic domain is a sequence of numbers for the days, hours, minutes, and seconds of duration, normalized such that the sum of these numbers is minimized. For example, **FEEL(duration("P0DT25H")) = P1DT1H**.

The value of a days and time duration can be expressed as a number of seconds. *E.g.*, **value_{dt}(P1DT1H) = 90000**. The **value_{dt}** function is one-to-one and so it has an inverse function **value_{dt}⁻¹**. *E.g.*, **value_{dt}⁻¹(90000) = P1DT1H**.

10.3.2.3.8 years and months duration

FEEL does not have duration literals, although we use boldface duration literals to represent values in the semantic domain. Durations can be expressed using a string literal and the *duration()* built-in function. The literal format of the characters within the quotes of the string literal is defined by the lexical space of the [XPath Data Model](#) yearMonthDuration datatype. A years and months duration in the semantic domain is a pair of numbers for the years and months of duration, normalized such that the sum of these numbers is minimized. For example, $FEEL(duration("P0Y13M")) = \mathbf{P1Y1M}$.

The value of a years and months duration can be expressed as a number of months. *E.g.*, $value_{ymd}(\mathbf{P1Y1M}) = 13$. The $value_{ymd}$ function is one-to-one and so it has an inverse function $value_{ymd}^{-1}$. *E.g.*, $value_{ymd}^{-1}(13) = \mathbf{P1Y1M}$.

10.3.2.4 Ternary logic

FEEL, like SQL and PMML, uses of ternary logic for truth values. This makes **and** and **or** complete functions from $D \times D \rightarrow D$. Ternary logic is used in [Predictive Modeling Markup Language](#) to model missing data values.

10.3.2.5 Lists and filters

Lists are immutable and may be nested. The *first* element of a list L can be accessed using $L[1]$ and the *last* element can be accessed using $L[-1]$. The n^{th} element from the beginning can be accessed using $L[n]$, and the n^{th} element from the end can be accessed using $L[-n]$.

If $FEEL(L) = \mathbf{L}$ is a list in the FEEL semantic domain, the first element is $FEEL(L[1]) = \mathbf{L}[1]$. If \mathbf{L} does not contain n items, then $\mathbf{L}[n]$ is **null**.

\mathbf{L} can be filtered with a Boolean expression in square brackets. The expression in square brackets can reference a list element using the name *item*, unless the list element is a context that contains the key "**item**". If the list element is a context, then its context entries may be referenced within the filter expression without the '*item.*' prefix. For example:

$$[1, 2, 3, 4][item > 2] = [3, 4]$$
$$[\{x:1, y:2\}, \{x:2, y:3\}][x=1] = \{x:1, y:2\}$$

The filter expression is evaluated for each item in list, and a list containing only items where the filter expression is **true** is returned.

Singleton lists are equal to their single item. Therefore, any function or operator that expects a list as input but instead receives a non-list semantic domain element e behaves as if it had received $[e]$ as input.

For convenience, a selection using the "." operator with a list of contexts on its left hand side returns a list of selections, *i.e.* $FEEL(e.f, \mathbf{c}) = [FEEL(f, \mathbf{c}'), FEEL(f, \mathbf{c}''), \dots]$ where $FEEL(e) = [\mathbf{e}', \mathbf{e}'', \dots]$ and \mathbf{c}' is \mathbf{c} augmented with the context entries of \mathbf{e}' , \mathbf{c}'' is \mathbf{c} augmented with the context entries of \mathbf{e}'' , etc. For example,

$$[\{x:1, y:2\}, \{x:2, y:3\}].y = [2,3]$$

10.3.2.6 Context

A FEEL context is a partially ordered collection of (key, expression) pairs called context entries. In the syntax, keys can be either names or strings. Keys are mapped to strings in the semantic domain. These strings are distinct within a context. A context in the domain is denoted using bold FEEL syntax with string keys, *e.g.* $\{ \mathbf{"key_1"} : \mathbf{expr_1}, \mathbf{"key_2"} : \mathbf{expr_2}, \dots \}$.

The syntax for selecting the value of the entry named key_1 from context-valued expression m is $m.key_1$.

If key_1 is not a legal name or for whatever reason one wishes to treat the key as a string, the following syntax is allowed: *get value*($m, "key_1"$). Selecting a value by key from context \mathbf{m} in the semantic domain is denoted as $\mathbf{m.key_1}$ or **get value**($\mathbf{m}, \mathbf{"key_1"}$)

To retrieve a list of key,value pairs from a context m , the following built-in function may be used: *get entries*(m).

For example, the following is true:

$$get\ entries(\{key_1: "value_1"\})[key="key_1"].value = "value_1"$$

An expression in a context entry may not reference the key of the same context entry, but may reference keys (as QNs) from other context entries in the same context. These references SHALL be acyclic and form a partial order. The expressions in a context SHALL be evaluated consistent with this partial order.

10.3.2.7 Ranges

FEEL supports a compact syntax for a range of values, useful in decision table test cells and elsewhere. A range maps to the semantic domain as a single comparable value (number, date/time/duration, or string) or a pair of comparable endpoint values and an endpoint inclusivity code that indicates whether one or both endpoints are included in the range.

The range syntax supports literal and symbolic endpoints, but not arbitrary expressions. Because date/time/duration values have no literal syntax, symbolic endpoints must be used for ranges of these types. *E.g.*, the following context defines a range of duration named *soon* from one to two minutes, inclusive.

```
{
    one min: duration("PT1M"),
    two min: duration("PT2M"),
    soon: [one min..two min]
}
```

10.3.2.8 Decision Table

The normative notation for decision tables is specified in clause 8. Each input expression SHALL be a textual expression (grammar rule 2) referencing one or more input variables (qualified names). Each list of input values SHALL be an instance of unary tests (grammar rule 17). The value that is tested is the value of the input expression of the containing clause. Each list of output values SHALL be an instance of unary tests (grammar rule 17). The value that is tested is the value of a selected output entry of the containing clause. Each input entry SHALL be an instance of unary tests (grammar rule 17). A textual representation using invocation of the decision table built-in function is provided here in order to tie the syntax to the semantics in the same way as is done for the rest of FEEL. Unary tests (grammar rule 17) cannot be mapped to the semantic domain in isolation, and are left as their syntactic forms, indicated by the enclosing single-quotes. For example, the first decision table in Table 26 can be represented textually as

decision table(

outputs: "Applicant Risk Rating",

input expression list: [Applicant Age, Medical History],

rule list: [

[>60', "good", "Medium"],

[>60', "bad", "High"],

[25..60]', '-', "Medium"],

[<25', "good", "Low"],

[<25', "bad", "Medium"]],

hit policy: "Unique")

The decision table built-in in clause 10.3.4.6 will compose the unary tests syntax into expressions that can be mapped to the FEEL semantic domain.

10.3.2.9 Scope and context stack

A FEEL expression *e* is always evaluated in a well-defined set of name bindings that are used to resolve QNs in *e*. This set of name bindings is called the scope of *e*. Scope is modeled as a list of contexts. A scope *s* contains the contexts with entries

that are in scope for e . The last context in \mathbf{s} is the *built-in* context. Next to last in \mathbf{s} is the *global* context. The first context in \mathbf{s} is the context immediately containing e (if any). Next are enclosing contexts of e (if any).

The QN of e is the QN of the first context in \mathbf{s} appended with $.N$, where N is the name of entry in the first context of \mathbf{s} containing e . QNs in e are resolved by looking through the contexts in \mathbf{s} from first to last.

10.3.2.9.1 Local context

If e denotes the value of a context entry of context \mathbf{m} , then \mathbf{m} is the local context for e , and \mathbf{m} is the first element of \mathbf{s} . Otherwise, e has no local context and the first element of \mathbf{s} is the global context, or in some cases explained later, the first element of \mathbf{s} is a special context.

All of the entries of \mathbf{m} are in-scope for e , but the *depends on* graph SHALL be acyclic. This provides a simple solution to the problem of the confusing definition above: if \mathbf{m} is the result of evaluating the context expression m that contains e , how can we know it in order to evaluate e ? Simply evaluate the context entries in *depends on* order.

10.3.2.9.2 Global context

The global context is a context provided for convenience and 'pre-compilation'. Any number of expressions can be named and represented in a FEEL context \mathbf{m} . The syntactic description m of this context can be evaluated once, that is, mapped to the FEEL domain as \mathbf{m} , and then re-used to evaluate many expressions.

10.3.2.9.3 Built-in context

The built-in context contains all the built-in functions.

10.3.2.9.4 Special context

Some FEEL expressions are interpreted in a *special* context that is pushed on the front of \mathbf{s} . For example, a filter expression is repeatedly executed with special first context containing the name 'item' bound to successive list elements. A function is executed with a special first context containing argument name->value mappings.

Qualified names (QNs) in FEEL expressions are interpreted relative to \mathbf{s} . The meaning of a FEEL expression e in scope \mathbf{s} is denoted as $\mathbf{FEEL}(e, \mathbf{s})$. We can also say that e evaluates to \mathbf{e} in scope \mathbf{s} , or $\mathbf{e} = \mathbf{FEEL}(e, \mathbf{s})$. Note that \mathbf{e} and \mathbf{s} are elements of the FEEL domain. \mathbf{s} is a list of contexts.

10.3.2.10 Mapping between FEEL and other domains

A FEEL expression e denotes a value \mathbf{e} in the semantic domain. Some kinds of values can be passed between FEEL and external Java methods, between FEEL and external PMML models, and between FEEL and XML, as summarized in the Table 35:

Table 35: Mapping between FEEL and other domains

<i>FEEL value</i>	<i>Java</i>	<i>XML</i>	<i>PMML</i>
number	java.math.BigDecimal	decimal	decimal, PROB-NUMBER, PERCENTAGE-NUMBER
		integer	integer , INT-NUMBER
		double	double, REAL-NUMBER
string	java.lang.String	string	string, FIELD-NAME
date and time, time	javax.xml.datatype.XMLGregorianCalendar	date, dateTime, time, dateTimeStamp	date, dateTime, time conversion required for dateDaysSince, <i>et. al.</i>

duration	javax.xml.datatype. Duration	yearMonthDuration, dayTimeDuration	X
boolean	java.lang.Boolean	boolean	boolean
range	<i>TBD</i>	<i>TBD</i>	<i>TBD</i>
function	X	X	X
list	java.util.List	contain multiple child elements	array (homogeneous)
context	java.util.Map	contain attributes and child elements	X

Sometimes we do not want to evaluate a FEEL expression e , we just want to know the type of e . Note that if e has QNs, then a context may be needed for type inference. We write $\mathbf{type}(e)$ as the type of the domain element $\mathbf{FEEL}(e, \mathbf{c})$.

10.3.2.11 Function Semantics

FEEL functions can be

- built-in, *e.g.*,
decision table (see clause 10.3.4.6), or
- user-defined, *e.g.*,
function(age) age < 21, or
- externally defined, *e.g.*,
function(angle) external {
 java: {
 class: "java.lang.Math",
 method signature: "cos(double)"
 }}

FEEL built-ins are specified in 10.3.4.

10.3.2.11.1 User-defined functions

User-defined functions have the form

function(X_1, \dots, X_n) e

The terms X_1, \dots, X_n are parameter names. The function body is e . The meaning of $\mathbf{FEEL}(\mathbf{function}(X_1, \dots, X_n) e, \mathbf{s})$ is an element in the FEEL semantic domain that we denote as **function(argument list: $[X_1, \dots, X_n]$, body: e , scope: \mathbf{s})** (shortened to **f** below). FEEL functions are lexical closures, *i.e.*, the body is an expression that references the formal parameters and any other names in scope \mathbf{s} .

The invocation of a FEEL user-defined function **f** is denoted as $\mathbf{f}(Y_1, \dots, Y_n)$. The meaning $\mathbf{FEEL}(\mathbf{f}(Y_1, \dots, Y_n), \mathbf{S})$, where **f** has already been interpreted, is computed as follows:

1. the parameter names X_1, \dots, X_n and corresponding values $\mathbf{Y}_1, \dots, \mathbf{Y}_n$ are paired in a context $\mathbf{c} = \{X_1 : \mathbf{Y}_1, \dots, X_n : \mathbf{Y}_n\}$. $\mathbf{Y}_i = \mathbf{FEEL}(Y_i, \mathbf{S})$.
2. e is interpreted in \mathbf{s}' , where $\mathbf{s}' = \mathbf{insert\ before}(\mathbf{s}, \mathbf{1}, \mathbf{c})$ (see 10.3.4.4)

10.3.2.11.2 Externally-defined functions

FEEL externally-defined functions have the following form

function($X_1, \dots X_n$) external mapping-information

Mapping-information is a context that SHALL have one of the following forms:

```
{  
  java: {class: class-name, method signature: method-signature}  
}
```

or

```
{  
  pmml: {document: IRI, model: model-name}  
}
```

The meaning of an externally defined function is an element in the semantic domain that we denote as **function(argument list: $[X_1, \dots X_n]$, external: mapping-information)**.

The *java* form of the mapping information indicates that the external function is to be accessed as a method on a Java class. The *class-name* SHALL be the string name of a Java class on the classpath. Classpath configuration is implementation-defined. The *method-signature* SHALL be a string consisting of the name of a public static method in the named class, followed by an argument list containing only Java argument type names. The argument type information SHOULD be used to resolve overloaded methods and MAY be used to detect out-of-domain errors before runtime.

The *pmml* form of the mapping information indicates that the external function is to be accessed as a PMML model. The *IRI* SHALL be the resource identifier for a PMML document. The *model-name* is optional. If the *model-name* is specified, it SHALL be the name of a model in the document to which the *IRI* refers. If no *model-name* is specified, the external function SHALL be the first model in the document.

When an externally-defined function is invoked, actual argument values and result value are converted when possible using the type mapping table for Java or PMML [ref to this table in Types and Inference]. When a conversion is not possible, **null** is substituted. If a result cannot be obtained, *e.g.* an exception is thrown, the result of the invocation is **null**.

Passing parameter values to the external method or model requires knowing the expected parameter types. For Java, this information is obtained using reflection. For PMML, this information is obtained from the mining schema and data dictionary elements associated with independent variables of the selected model.

Note that **DMN** does not completely define the semantics of a Decision Model that uses externally-defined functions. Externally-defined functions SHOULD have no side-effects and be deterministic.

10.3.2.11.3 Function name

To name a function, define it as a context entry. *E.g.*

```
{  
  isPositive : function(x) x > 0,  
  isNotNegative : function(x) isPositive(x+1),  
  result: isNotNegative(0)  
}
```

10.3.2.11.4 Positional and named parameters

An invocation of any FEEL function (built-in, user-defined, or externally-defined) can use positional parameters or named parameters. If positional, all parameters SHALL be supplied. If named, unsupplied parameters are bound to **null**.

10.3.2.12 Semantic mappings

The meaning of each substantive grammar rule is given below by mapping the syntax to a value in the semantic domain. The value may depend on certain input values, themselves having been mapped to the semantic domain. The input values may

have to obey additional constraints. The input domain(s) may be a subset of the semantic domain. Inputs outside of their domain result in a **null** value.

Table 36: Semantics of FEEL functions

Grammar Rule	FEEL Syntax	Mapped to Domain
57	<i>function(n_1, \dots, n_N) e</i>	function(argument list: [n_1, \dots, n_N], body: e, scope: s)
57	<i>function(n_1, \dots, n_N) external e</i>	function(argument list: [n_1, \dots, n_N], external: e)

See 10.3.2.7.

Table 37: Semantics of other FEEL expressions

Grammar Rule	FEEL Syntax	Mapped to Domain
46	<i>for n_1 in e_1, n_2 in e_2, ... return e</i>	[FEEL(e, s'), FEEL(e, s''), ...]
47	<i>if e_1 then e_2 else e_3</i>	if FEEL(e_1) is true then FEEL(e_2) else FEEL(e_3)
48	<i>some n_1 in e_1, n_2 in e_2, ... satisfies e</i>	FEEL(e, s') or FEEL(e, s'') or ...
48	<i>every n_1 in e_1, n_2 in e_2, ... satisfies e</i>	FEEL(e, s') and FEEL(e, s'') and ...
49	<i>e_1 or e_2 or ...</i>	FEEL(e_1) or FEEL(e_2) or ...
50	<i>e_1 and e_2 and ...</i>	FEEL(e_1) and FEEL(e_2) and ...
51.a	<i>$e = null$</i>	FEEL(e) is null
51.a	<i>$null = e$</i>	FEEL(e) is null
51.a	<i>$e \neq null$</i>	FEEL(e) is not null
51.a	<i>$null \neq e$</i>	FEEL(e) is not null

Notice that we use bold syntax to denote contexts, lists, conjunctions, disjunctions, conditional expressions, true, false, and null in the FEEL domain.

The meaning of the conjunction **a and b** and the disjunction **a or b** is defined by ternary logic. Because these are total functions, the input can be **true**, **false**, or **otherwise** (meaning any element of **D** other than **true** or **false**).

Table 38: Semantics of conjunction and disjunction

a	b	a and b	a or b
true	true	true	true
true	false	false	true
true	otherwise	null	true
false	true	false	true
false	false	false	false
false	otherwise	false	null
otherwise	true	null	true
otherwise	false	false	null
otherwise	otherwise	null	null

Negation is accomplished using the built-in function **not**. The ternary logic is as shown in Table 39.

Table 39: Semantics of negation

a	not(a)
true	false
false	true
otherwise	null

A conditional **if a then b else c** is equal to **b** if **a** is **true**, and equal to **c** otherwise.

s' is the scope **s** with a special first context containing keys n_1, n_2, \dots , etc. bound to the first element of the Cartesian product of $FEEL(e_1) \times FEEL(e_2) \times \dots$, **s''** is **s** with a special first context containing keys bound to the second element of the Cartesian product, *etc.*

Equality and inequality map to several kind- and datatype-specific tests, as shown in Table 40, Table 41 and Table 42. By definition, $FEEL(e_1 \neq e_2)$ is $FEEL(not(e_1=e_2))$. The other comparison operators are defined only for the datatypes listed in Table 42. Note that Table 42 defines only '<'; '>' is similar to '<' and is omitted for brevity; $e_1 <= e_2$ is defined as $e_1 < e_2$ or $e_1 = e_2$.

Table 40: General semantics of equality and inequality

Grammar Rule	FEEL Syntax	Input Domain	Result

51.a	$e_1 = e_2$	e1 and e2 must both be of the same kind/datatype – both numbers, both strings, etc.	<i>See below</i>
51.a	$e_1 < e_2$	e1 and e2 must both be of the same kind/datatype – both numbers, both strings, etc.	<i>See below</i>

Table 41: Specific semantics of equality

kind/datatype	$e_1 = e_2$
list	lists must be same length N and $e_1[i] = e_2[i]$ for $1 \leq i \leq N$.
context	contexts must have same set of keys K and $e_1.k = e_2.k$ for every k in K
range	the ranges must specify the same endpoints and the same endpoint inclusivity code.
function	internal functions must have the same parameters, body, and scope. Externally defined functions must have the same parameters and external mapping information.
number	value(e₁) = value(e₂) . Value is defined in 10.3.2.3.1. Precision is not considered.
string	e₁ is the same sequence of characters as e₂
date	all 3 components (10.3.2.3.5) must be equal
date and time	all 7 components (10.3.2.3.5), treating unspecified optional components as null, must be equal
time	all 4 components (10.3.2.3.4), treating unspecified optional components as null, must be equal
days and time duration	value(e₁) = value(e₂) . Value is defined in 10.3.2.3.7.
years and months duration	value(e₁) = value(e₂) . Value is defined in 10.3.2.3.8.
boolean	e₁ and e₂ must both be true or both be false

Table 42: Specific semantics of inequality

datatype	$e_1 < e_2$
number	value(e₁) < value(e₂) . value is defined in 10.3.2.3.1. Precision is not considered.

string	sequence of characters e_1 is lexicographically less than the sequence of characters e_2 . <i>I.e.</i> , the sequences are padded to the same length if needed with <code>\u00</code> characters, stripped of common prefix characters, and then the first character in each sequence is compared.
date	$e_1 < e_2$ if the year value of $e_1 <$ the year value of e_2 $e_1 < e_2$ if the year values are equal and the month value of $e_1 <$ the month value of e_2 $e_1 < e_2$ if the year and month values are equal and the day value of $e_1 <$ the day value of e_2
date and time	value_{at}(e_1) < value_{at}(e_2). value_{at} is defined in 10.3.2.3.5. If one input has a null timezone offset, that input uses the timezone offset of the other input.
time	value_t(e_1) < value_t(e_2). value_t is defined in 10.3.2.3.4. If one input has a null timezone offset, that input uses the timezone offset of the other input.
days and time duration	value_{dttd}(e_1) < value_{dttd}(e_2). value_{dttd} is defined in 10.3.2.3.7.
years and months duration	value_{ymd}(e_1) < value_{ymd}(e_2). value_{ymd} is defined in 10.3.2.3.8.

FEEL supports additional syntactic sugar for comparison. Note that Grammar Rules (clause 10.3.1.2) are used in decision table condition cells. In Grammar Rule **51c**, the qualified name must evaluate to a comparable constant value at modeling time, *i.e.* the endpoint must be a literal or a named constant. These decision table syntaxes are defined in Table 43.

Table 43: Semantics of decision table syntax

Grammar Rule	FEEL Syntax	Equivalent FEEL Syntax	applicability
51.b	e_1 between e_2 and e_3	$e_1 \geq e_2$ and $e_1 \leq e_3$	
51.c	e_1 in [e_2, e_3, \dots]	$e_1 = e_2$ or $e_1 = e_3$ or...	e_2 and e_3 are endpoints
51.c	e_1 in [e_2, e_3, \dots]	e_1 in e_2 or e_1 in e_3 or...	e_2 and e_3 are ranges
51.c	e_1 in $\leq e_2$	$e_1 \leq e_2$	
51.c	e_1 in $< e_2$	$e_1 < e_2$	
51.c	e_1 in $\geq e_2$	$e_1 \geq e_2$	
51.c	e_1 in $< e_2$	$e_1 < e_2$	
51.c	e_1 in ($e_2..e_3$)	$e_1 > e_2$ and $e_1 < e_3$	
51.c	e_1 in ($e_2..e_3$]	$e_1 > e_2$ and $e_1 \leq e_3$	

51.c	$e_1 \text{ in } [e_2..e_3)$	$e_1 \geq e_2 \text{ and } e_1 < e_3$	
51.c	$e_1 \text{ in } [e_2..e_3]$	$e_1 \geq e_2 \text{ and } e_1 \leq e_3$	

Addition and subtraction are defined in Table 44 and Table 45. Note that if input values are not of the listed types, the result is **null**.

Table 44: General semantics of addition and subtraction

Grammar Rule	FEEL	Input Domain and Result
21	$e_1 + e_2$	See below
22	$e_1 - e_2$	See below

Table 45: Specific semantics of addition and subtraction

type(e_1)	type(e_2)	$e_1 + e_2, e_1 - e_2$	result type
number	number	Let $e_1=(p_1,s_1)$ and $e_2=(p_2,s_2)$ as defined in 10.3.2.3.1. If value (p_1,s_1) +/- value (p_2,s_2) requires a scale outside the range of valid scales, the result is null . Else the result is (p , s) such that <ul style="list-style-type: none"> • value(p,s) = value(p_1,s_1) +/- value(p_2,s_2) + ϵ • $s \leq \max(s_1,s_2)$ • s is maximized subject to the limitation that p has 34 digits or less • ϵ is a possible rounding error. 	number
date and time	date and time	Addition is undefined. Subtraction is defined as value _{dt} ⁻¹ (value _{dt} (e_1)- value _{dt} (e_2)), where value _{dt} is defined in 10.3.2.3.5 and value _{dt} ⁻¹ is defined in 10.3.2.3.7.	days and time duration
time	time	Addition is undefined. Subtraction is defined as value _{dt} ⁻¹ (value _t (e_1)- value _t (e_2)) where value _t is defined in 10.3.2.3.4 and value _{dt} ⁻¹ is defined in 10.3.2.3.7.	days and time duration
years and months duration	years and months duration	value _{ymd} ⁻¹ (value _{ymd} (e_1) +/- value _{ymd} (e_2)) where value _{ymd} and value _{ymd} ⁻¹ is defined in 10.3.2.3.8.	years and months duration
days and time duration	days and time duration	value _{dt} ⁻¹ (value _{dt} (e_1) +/- value _{dt} (e_2)) where value _{dt} and value _{dt} ⁻¹ is defined in 10.3.2.3.7	days and time duration

date and time	years and months duration	date and time ($\text{date}(e_1.\text{year} \pm e_2.\text{years} + \text{floor}((e_1.\text{month} \pm e_2.\text{months})/12), e_1.\text{month} \pm e_2.\text{months} - \text{floor}((e_1.\text{month} \pm e_2.\text{months})/12) * 12, e_1.\text{day}), \text{time}(e_1))$, where the named properties are as defined in Table 53 below, and the date, date and time, time and floor functions are as defined in 10.3.4, value_{dt} and value_{dt}^{-1} is defined in 10.3.2.3.5 and value_{ymd} is defined in 10.3.2.3.8.	date and time
years and months duration	date and time	Subtraction is undefined. Addition is commutative and is defined by the previous rule.	date and time
date and time	days and time duration	$\text{value}_{dt}^{-1}(\text{value}_{dt}(e_1) \pm \text{value}_{dtd}(e_2))$ where value_{dt} and value_{dt}^{-1} is defined in 10.3.2.3.5 and value_{dtd} is defined in 10.3.2.3.7.	date and time
days and time duration	date and time	Subtraction is undefined. Addition is commutative and is defined by the previous rule.	date and time
time	days and time duration	$\text{value}_t^{-1}(\text{value}_t(e_1) \pm \text{value}_{dtd}(e_2))$ where value_t and value_t^{-1} is defined in 10.3.2.3.4 and value_{dtd} is defined in 10.3.2.3.7.	time
days and time duration	time	Subtraction is undefined. Addition is commutative and is defined by the previous rule.	time
string	string	Subtraction is undefined. Addition concatenates the strings. The result is a string containing the sequence of characters in e_1 followed by the sequence of characters in e_2 .	string

Multiplication and division are defined in Table 46 and Table 47. Note that if input values are not of the listed types, the result is **null**.

Table 46: General semantics of multiplication and division

Grammar Rule	FEEL	Input Domain and Result
23	$e_1 * e_2$	<i>See below</i>
24	e_1 / e_2	<i>See below</i>

Table 47: Specific semantics of multiplication and division

type(e_1)	type(e_2)	$e_1 * e_2$	e_1 / e_2	result type
number $e_1=(p_1,s_1)$	number $e_2=(p_2,s_2)$	<p>If value(p_1,s_1) * value(p_2,s_2) requires a scale outside the range of valid scales, the result is null. Else the result is (p,s) such that</p> <ul style="list-style-type: none"> • value(p,s) = value(p_1,s_1) * value(p_2,s_2) + ϵ • $s \leq s_1+s_2$ • s is maximized subject to the limitation that p has 34 digits or less • ϵ is a possible rounding error 	<p>If value(p_2,s_2)=0 or value(p_1,s_1) / value(p_2,s_2) requires a scale outside the range of valid scales, the result is null. Else the result is (p,s) such that</p> <ul style="list-style-type: none"> • value(p,s) = value(p_1,s_1) / value(p_2,s_2) + ϵ • $s \leq s_1-s_2$ • s is maximized subject to the limitation that p has 34 digits or less • ϵ is a possible rounding error 	number
years and months duration	number	value_{ymd}⁻¹(value_{ymd}(e_1) * value(e_2)) where value_{ymd} and value_{ymd}⁻¹ are defined in 10.3.2.3.8.	If value(e_2)=0 , the result is null . Else the result is value_{ymd}⁻¹(value_{ymd}(e_1) / value(e_2)) where value_{ymd} and value_{ymd}⁻¹ are defined in 10.3.2.3.8.	years and months duration
number	years and months duration	<i>see above, reversing e_1 and e_2</i>		
days and time duration	number	value_{dttd}⁻¹(value_{dttd}(e_1) * value(e_2)) where value_{dttd} and value_{dttd}⁻¹ are defined in 10.3.2.3.7.	If value(e_2)=0 , the result is null . Else the result is value_{dttd}⁻¹(value_{dttd}(e_1) * value(e_2)) where value_{dttd} and value_{dttd}⁻¹ are defined in 10.3.2.3.7.	days and time duration
number	days and time duration	<i>see above, reversing e_1 and e_2</i>		

Exponentiation is defined in Table 48.

Table 48: Semantics of exponentiation

Grammar Rule	FEEL Syntax	Input Domain	Result
25	$e_1 ** e_2$	type (e_1) is number. value (e_2) is an integer in the range [-999,999,999..999,999,999].	<p>If value(e_1)^{value(e_2)} requires a scale that is out of range, the result is null. Else the result is (p,s) such that</p> <ul style="list-style-type: none"> • value(p,s)= value(e_1)^{value(e_2)} + ϵ • p is limited to 34 digits • ϵ is rounding error

Type-checking is defined in Table 49. Note that *type* is not mapped to the domain, and *null* is not the name of a type, and **null** is not an instance of any type.

Table 49: Semantics of type-checking

Grammar Rule	FEEL Syntax	Mapped to Domain
53	<i>e instance of type</i>	true iff type (e) is <i>type</i>

Negative numbers are defined in Table 50.

Table 50: Semantics of negative numbers

Grammar Rule	FEEL Syntax	Equivalent FEEL Syntax
26	<i>-e</i>	<i>0-e</i>

Invocation is defined in Table 51. An invocation can use positional arguments or named arguments. If positional, all arguments must be supplied. If named, unsupplied arguments are bound to **null**. Note that **e** can be a user-defined function, a user-defined external function, or a built-in function.

Table 51: Semantics of invocation

Grammar Rule	FEEL	Mapped to Domain	Applicability
40, 41, 44	$e(e_1, \dots)$	e (e ₁ ,...))	e is a function with matching arity
40, 41, 42, 43	$e(n_1; e_1, \dots)$	e (n ₁ ; e ₁ ,...))	e is a function with matching parameter names

Properties are defined in Table 52 and Table 53. If **type(e)** is date and time, time, or duration, and **name** is a property name, then the meaning is given by Table 53. For example, $FEEL(date\ and\ time("03-07-2012Z")).year = 2012$.

Table 52: General semantics of properties

Grammar Rule	FEEL	Mapped to Domain	Applicability
20	<i>e.name</i>	e."name"	type(e) is a context
20	<i>e.name</i>	<i>see below</i>	type(e) is a date/time/duration

Table 53: Specific semantics of date, time and duration properties

type(e)	<i>e . name</i>	name =
date	result is the named component of the date object e . Valid names are shown to the right.	year, month, day
date and time	result is the named component of the date and time object e . Valid names are shown to the right. time offset and timezone may be null	year, month, day, hour, minute, second, time offset, timezone
time	result is the named component of the time object e . Valid names are shown to the right. time offset and timezone may be null	hour, minute, second, time offset, timezone
years and months duration	result is the named component of the years and months duration object e . Valid names are shown to the right.	years, months
days and time duration	result is the named component of the days and time duration object e . Valid names are shown to the right.	days, hours, minutes, seconds

Lists are defined in Table 54.

Table 54: Semantics of lists

Grammar Rule	FEEL Syntax	Mapped to Domain (scope s)	Applicability
56	<i>e₁[e₂]</i>	e₁[e₂]	e₁ is a list and e₂ is an integer (0 scale number)
56	<i>e₁[e₂]</i>	e₁	e₁ is not a list and not null and value(e₂) = 1

56	$e_1[e_2]$	list of items e such that i is in e iff i is in e_1 and $\text{FEEL}(e_2, s')$ is true , where s' is the scope s with a special first context containing the context entry (" item ", i) and if i is a context, the special context also contains all the context entries of i .	e_1 is a list and $\text{type}(\text{FEEL}(e_2, s'))$ is boolean
56	$e_1[e_2]$	$[e_1]$ if $\text{FEEL}(e_2, s')$ is true , where s' is the scope s with a special first context containing the context entry (" item ", e_1) and if e_1 is a context, the special context also contains all the context entries of e_1 . Else $[]$.	e_1 is not a list and not null and $\text{type}(\text{FEEL}(e_2, s'))$ is boolean

Contexts are defined in Table 55.

Table 55: Semantics of contexts

Grammar Rule	FEEL Syntax	Mapped to Domain (scope s)
59	$\{n_1 : e_1, n_2 : e_2, \dots\}$	$\{ "n_1": \text{FEEL}(e_1, s_1), "n_2": \text{FEEL}(e_2, s_2), \dots \}$ such that the s_i are all s with a special first context c_i containing a subset of the entries of this result context. If c_i contains the entry for n_j , then c_j does not contain the entry for n_i .
	$\{ "n_1" : e_1, "n_2" : e_2, \dots \}$	
56	$[e_1, e_2, \dots]$	$[\text{FEEL}(e_1), \text{FEEL}(e_2), \dots]$

10.3.2.13 Error Handling

When a built-in function encounters input that is outside its defined domain, the function SHOULD report or log diagnostic information if appropriate, and SHALL return **null**.

10.3.3 XML Data

FEEL supports XML Data in the FEEL context by mapping XML Data into the FEEL Semantic Domain. Let $\text{XE}(e, \mathbf{p})$ be a function mapping an XML element e and a parent FEEL context \mathbf{p} to a FEEL context, as defined in the following tables. XE makes use of another mapping function, $\text{XV}(v)$, that maps an XML value v to the FEEL semantic domain.

XML namespace semantics are not supported by the mappings. For example, given the namespace prefix declarations $\text{xmlns:p1}="http://example.org/foobar"$ and $\text{xmlns:p2}="http://example.org/foobar"$, the tags $p1:\text{myElement}$ and $p2:\text{myElement}$ are the same element using XML namespace semantics but are different using XML without namespace semantics.

10.3.3.1 Semantic mapping for XML elements (XE)

Table 56, e is the name of an XML element, a is the name of one of its attributes, c is a child element, and v is a value. The parent context \mathbf{p} is initially empty.

Table 56: Semantics of XML elements

XML	context entry in p	Remark
<code><e /></code>	"e" : null	empty element → null-valued entry in p
<code><q:e /></code>	"q\$e" : null	namespaces are ignored. Colonized names are changed to legal identifiers.
<code><e>v</e></code>	"e":XV(v)	unrepeated element without attributes
<code><e>v₁</e> <e>v₂</e></code>	"e": [XV(v ₁), XV(v ₂)]	repeating element without attributes
<code><e a="v"/> <c₁>v₁</c₁> <c_n>v₂</c_n><c_n>v₃</c_n> </e></code>	"e": { "@a": XV(v), "c ₁ ": XV(v ₁), "c _n ": [XV(v ₂), XV(v ₃)] }	attribute names are prefixed with @. An element containing attributes or child elements → context
<code><e a="v₁">v₂</e></code>	"e": { "@a": XV(v ₁), "\$content": XV(v ₂) }	v ₂ is contained in a generated \$content entry

An entry in the **context entry in p** column such as "e" : null indicates a context entry with string key "e" and value null. The context entries are contained by context **p** that corresponds to the containing XML element, or to the XML document itself.

The mapping does not replace namespace prefixes with the namespace IRIs. FEEL requires only that keys within a context be distinct, and the namespace prefixes are sufficient.

10.3.3.2 Semantic mapping for XML values (XV)

If an XML document was parsed with a schema, then some atomic values may have a datatype other than string. Table 57 defines how a typed XML value *v* is mapped to FEEL.

Table 57: Semantics of XML values

Type of <i>v</i>	FEEL Semantic Domain
number	FEEL(<i>v</i>)
string	FEEL("v")
date	"@a": FEEL(date("v"))
dateTime	"@a": FEEL(date and time("v"))
time	"@a": FEEL(time("v"))
duration	"@a": FEEL(duration("v"))

list, e.g. " $v_1 v_2$ "	[$XV(v_1), XV(v_2)$]
element	$XE(v)$

10.3.3.3 XML example

The following schema and instance are equivalent to the following FEEL:

10.3.3.3.1 schema

```
<xsd:schema xmlns:xsd="http://www.w3.org/2001/XMLSchema"
  xmlns="http://www.example.org"
  targetNamespace="http://www.example.org"
  elementFormDefault="qualified">
  <xsd:element name="Context">
    <xsd:complexType>
      <xsd:sequence>
        <xsd:element name="Employee">
          <xsd:complexType>
            <xsd:sequence>
              <xsd:element name="salary" type="xsd:decimal"/>
            </xsd:sequence>
          </xsd:complexType>
        </xsd:element>
        <xsd:element name="Customer" maxOccurs="unbounded">
          <xsd:complexType>
            <xsd:sequence>
              <xsd:element name="loyalty_level" type="xsd:string"/>
              <xsd:element name="credit_limit" type="xsd:decimal"/>
            </xsd:sequence>
          </xsd:complexType>
        </xsd:element>
      </xsd:sequence>
    </xsd:complexType>
  </xsd:element>
</xsd:schema>
```

10.3.3.3.2 instance

```
<Context xmlns:tns="http://www.example.org"
  xmlns="http://www.example.org">
  <tns:Employee>
    <tns:salary>13000</tns:salary>
  </tns:Employee>
  <Customer>
    <loyalty_level>gold</loyalty_level>
    <credit_limit>10000</credit_limit>
  </Customer>
  <Customer>
    <loyalty_level>gold</loyalty_level>
    <credit_limit>20000</credit_limit>
  </Customer>
</Context>
```



```

</Customer>
<Customer>
  <loyalty_level>silver</loyalty_level>
  <credit_limit>5000</credit_limit>
</Customer>
</Context>

```

10.3.3.3 equivalent FEEL boxed context

Context		
tns\$Employee	tns\$salary	13000
Customer	loyalty_level	credit_limit
	<i>gold</i>	10000
	<i>gold</i>	20000
	<i>silver</i>	5000

When a decision model is evaluated, its input data described by an item definition such as an XML Schema element (clause 7.3.2) is bound to case data mapped to the FEEL domain. The case data can be in various formats, such as XML. We can notate case data as an equivalent boxed context, as above. Decision logic can reference entries in the context using expressions such as *Context.tns\$Employee.tns\$salary*, which has a value of 13000.

10.3.4 Built-in functions

To promote interoperability, FEEL includes a library of built-in functions. The syntax and semantics of the built-ins are required for a conformant FEEL implementation.

In all of the tables in this section, a superscript refers to an additional domain constraint stated in the corresponding footnote to the table. Whenever a parameter is outside its domain, the result of the built-in is **null**.

10.3.4.1 Conversion functions

FEEL supports many conversions between values of different types. Of particular importance is the conversion from strings to dates, times, and durations. There is no literal representation for date, time, or duration. Also, formatted numbers such as *1,000.00* must be converted from a string by specifying the grouping separator and the decimal separator.

Built-ins are summarized in Table 58. The first column shows the name and parameters. A question mark (?) denotes an optional parameter. The second column specifies the domain for the parameters. The parameter domain is specified as one of

- a type, *e.g.* number, string
- any – any element from the semantic domain, including **null**
- not null – any element from the semantic domain, excluding **null**.
- date string – a string value in the lexical space of the date datatype specified by XML Schema Part 2 Datatypes
- time string – either
 - a string value in the lexical space of the time datatype specified by XML Schema Part 2 Datatypes; or
 - a string value that is the extended form of a local time representation as specified by ISO 8601, followed by the

character "@", followed by a string value that is a time zone identifier in the IANA Time Zones Database (<http://www.iana.org/time-zones>)

- date time string – a string value consisting of a date string value, as specified above, optionally followed by the character "T" followed by a time string value as specified above
- duration string – a string value in the lexical space of the xs:dayTimeDuration or xs:yearMonthDuration datatypes specified by the XQuery 1.0 and XPath 2.0 Data Model.

Table 58: Semantics of conversion functions

Name(parameters)	Parameter Domain	Description	Example
date(<i>from</i>)	date string	convert <i>from</i> to a date	<i>date</i> ("2012-12-25") – <i>date</i> ("2012-12-24") = <i>duration</i> ("P1D")
date(<i>from</i>)	date and time	convert <i>from</i> to a date (set time components to null)	<i>date</i> (<i>date and time</i> ("2012-12-25T11:00:00Z")) = <i>date</i> ("2012-12-25")
date(<i>year, month, day</i>)	<i>year, month, day</i> are numbers	creates a date from year, month, day component values	<i>date</i> (2012, 12, 25) = <i>date</i> ("2012-12-25")
date and time(<i>date, time</i>)	<i>date</i> is a date or date time; <i>time</i> is a time	creates a date time from the given date (ignoring any time component) and the given time	<i>date and time</i> ("2012-12-24T23:59:00") = <i>date and time</i> (<i>date</i> ("2012-12-24"), <i>time</i> ("T23:59:00"))
date and time(<i>from</i>)	date time string	convert <i>from</i> to a date and time	<i>date and time</i> ("2012-12-24T23:59:00") + <i>duration</i> ("PT1M") = <i>date and time</i> ("2012-12-25T00:00:00")
time(<i>from</i>)	time string	convert <i>from</i> to time	<i>time</i> ("23:59:00z") + <i>duration</i> ("PT2M") = <i>time</i> ("00:01:00@Etc/UTC")
time(<i>from</i>)	time, date and time	convert <i>from</i> to time (ignoring date components)	<i>time</i> (<i>date and time</i> ("2012-12-25T11:00:00Z")) = <i>time</i> ("11:00:00Z")
time(<i>hour, minute, second, offset</i>)	<i>hour, minute, second</i> , are numbers, <i>offset</i> is a days and time duration, or null	creates a time from the given component values	<i>time</i> ("T23:59:00z") = <i>time</i> (23, 59, 0, <i>duration</i> ("PT0H"))
number(<i>from, grouping separator, decimal separator</i>)	string ¹ , string, string	convert <i>from</i> to a number	<i>number</i> ("1 000,0", " ", ".") = <i>number</i> ("1,000.0", ",", ".")

string(<i>from</i>)	non-null	convert <i>from</i> to a string	<i>string</i> (1.1) = "1.1" <i>string</i> (null) = null
duration(<i>from</i>)	duration string	convert <i>from</i> to a days and time or years and months duration	<i>date and time</i> ("2012-12-24T23:59:00") - <i>date and time</i> ("2012-12-22T03:45:00") = <i>duration</i> ("P2DT20H14M") <i>duration</i> ("P2Y2M") = <i>duration</i> ("P26M")
years and months duration(<i>from, to</i>)	both are date and time	return years and months duration between <i>from</i> and <i>to</i>	<i>years and months duration</i> (<i>date</i> ("2011-12-22"), <i>date</i> ("2013-08-24")) = <i>duration</i> ("P1Y8M")

1. *grouping* SHALL be one of space (' '), comma (','), period (('.'), or null.
decimal SHALL be one of period, comma, or null, but SHALL NOT be the same as the grouping separator unless both are null.
from SHALL conform to grammar rule 37, after removing all occurrences of the grouping separator, if any, and after changing the decimal separator, if present, to a period.

10.3.4.2 Boolean function

Table 59 defines Boolean functions.

Table 59: Semantics of Boolean functions

Name(parameters)	Parameter Domain	Description	Example
not(<i>negand</i>)	boolean	logical negation	<i>not</i> (true) = false <i>not</i> (null) = null

10.3.4.3 String functions

Table 60 defines string functions.

Table 60: Semantics of string functions

Name(parameters)	Parameter Domain	Description	Example
substring(<i>string, start position, length?</i>)	string, number ¹	return <i>length</i> (or all) characters in <i>string</i> , starting at <i>start position</i> . 1 st position is 1, last position is -1	<i>substring</i> ("foobar",3) = "obar" <i>substring</i> ("foobar",3,3) = "oba" <i>substring</i> ("foobar", -2, 1) = "a"
string length(<i>string</i>)	string	return length of <i>string</i>	<i>string length</i> ("foo") = 3

upper case(<i>string</i>)	string	return uppercased <i>string</i>	<i>upper case</i> ("aBc4") = "ABC4"
lower case(<i>string</i>)	string	return lowercased <i>string</i>	<i>lower case</i> ("aBc4") = "abc4"
substring before (<i>string, match</i>)	string, string	return substring of <i>string</i> before the <i>match</i> in <i>string</i>	<i>substring before</i> ("foobar", "bar") = "foo" <i>substring before</i> ("foobar", "xyz") = ""
substring after (<i>string, match</i>)	string, string	return substring of <i>string</i> after the <i>match</i> in <i>string</i>	<i>substring after</i> ("foobar", "ob") = "ar" <i>substring after</i> ("", "a") = ""
replace(<i>input, pattern, replacement, flags?</i>)	string ²	regular expression pattern matching and replacement	<i>replace</i> ("abcd", "(ab) (a)", "[1=\$1][2=\$2]") = "[1=ab][2=]cd"
contains(<i>string, match</i>)	string	does the <i>string</i> contain the <i>match</i> ?	<i>contains</i> ("foobar", "of") = false
starts with(<i>string, match</i>)	string	does the <i>string</i> start with the <i>match</i> ?	<i>starts with</i> ("foobar", "fo") = true
ends with(<i>string, match</i>)	string	does the <i>string</i> end with the <i>match</i> ?	<i>ends with</i> ("foobar", "r") = true
matches(<i>input, pattern, flags?</i>)	string ²	does the <i>input</i> match the regexp <i>pattern</i> ?	<i>matches</i> ("foobar", "^fo*b") = true

1. *start position* must be a non-zero integer (0 scale number) in the range [-L..L], where L is the length of the string. *length* must be in the range [1..E], where E is L – *start position* if *start position* is positive, and –*start position* otherwise.
2. *pattern, replacement, and flags* SHALL conform to the syntax and constraints specified in clause 7.6 of XQuery 1.0 and XPath 2.0 Functions and Operators. Note that where XPath specifies an error result, FEEL specifies a null result.

10.3.4.4 List functions

Table 61 defines list functions.

Table 61: Semantics of list functions

Name(parameters)	Parameter Domain	Description	Example
list contains(<i>list, element</i>)	list, any element of the semantic domain including null	does the <i>list</i> contain the <i>element</i> ?	<i>list contains</i> ([1,2,3], 2) = true
count(<i>list</i>)	list	return size of <i>list</i>	<i>count</i> ([1,2,3]) = 3

$\min(list)$ $\min(c_1, \dots, c_N), N > 1$ $\max(list)$ $\max(c_1, \dots, c_N), N > 1$	(list of) comparable items	return minimum(maximum) item	$\min([1,2,3]) = 1$ $\min(1,2,3) = 1$ $\max([1,2,3]) = 3$ $\max(1,2,3) = 3$
$\text{sum}(list)$ $\text{sum}(n_1, \dots, n_N), N > 1$	(list of) numbers	return sum of numbers	$\text{sum}([1,2,3]) = 6$ $\text{sum}(1,2,3) = 6$
$\text{mean}(list)$ $\text{mean}(n_1, \dots, n_N), N > 1$	(list of) numbers	return arithmetic mean (average) of numbers	$\text{mean}([1,2,3]) = 2$ $\text{mean}(1,2,3) = 2$
$\text{and}(list)$ $\text{and}(b_1, \dots, b_N), N > 1$	(list of) Boolean items	return <i>false</i> if any item is <i>false</i> , else <i>true</i> if all items are <i>true</i> , else <i>null</i>	$\text{and}([false,null,true]) = false$ $\text{and}(false,null,true) = false$ $\text{and}([]) = true$ $\text{and}(0) = null$
$\text{or}(list)$ $\text{or}(b_1, \dots, b_N), N > 1$	(list of) Boolean items	return <i>true</i> if any item is <i>true</i> , else <i>false</i> if all items are <i>false</i> , else <i>null</i>	$\text{or}([false,null,true]) = true$ $\text{or}(false,null,true) = true$ $\text{or}([]) = false$ $\text{or}(0) = null$
$\text{sublist}(list, \text{start position}, \text{length?})$	list, number ¹ , number ²	return list of <i>length</i> (or all) elements of <i>list</i> , starting with <i>list[start position]</i> . 1 st position is 1, last position is -1	$\text{sublist}([1,2,3], 1, 2) = [2]$
$\text{append}(list, \text{item} \dots)$	list, any element including null	return new <i>list</i> with <i>items</i> appended	$\text{append}([1], 2, 3) = [1,2,3]$
$\text{concatenate}(list \dots)$	list	return new <i>list</i> that is a concatenation of the arguments	$\text{concatenate}([1,2],[3]) = [1,2,3]$
$\text{insert before}(list, \text{position}, \text{newItem})$	list, number ¹ , any element including null	return new <i>list</i> with <i>newItem</i> inserted at <i>position</i>	$\text{insert before}([1,3], 1, 2) = [1,2,3]$
$\text{remove}(list, \text{position})$	list, number ¹	<i>list</i> with item at <i>position</i> removed	$\text{remove}([1,2,3], 2) = [1,3]$
$\text{reverse}(list)$	list	reverse the <i>list</i>	$\text{reverse}([1,2,3]) = [3,2,1]$
$\text{index of}(list, \text{match})$	list, any element including null	return ascending list of <i>list</i> positions containing <i>match</i>	$\text{index of}([1,2,3,2], 2) = [2,4]$
$\text{union}(list \dots)$	list	concatenate with duplicate removal	$\text{union}([1,2],[2,3]) = [1,2,3]$
$\text{distinct values}(list)$	list	duplicate removal	$\text{distinct values}([1,2,3,2,1]) = [1,2,3]$

<code>flatten(list)</code>	list	flatten nested lists	<code>flatten([[1,2],[3]], 4) = [1,2,3,4]</code>
----------------------------	------	----------------------	--

1. *position* must be a non-zero integer (0 scale number) in the range [-L..L], where L is the length of the list
2. *length* must be in the range [1..E], where E is L – *start position* if *start position* is positive, and –*start position* otherwise.

10.3.4.5 Numeric functions

Table 62 defines numeric functions.

Table 62: Semantics of numeric functions

Name(parameters)	Parameter Domain	Description	Example
<code>decimal(n, scale)</code>	number, number ¹	return <i>n</i> with given <i>scale</i>	<code>decimal(1/3, 2) = .33</code> <code>decimal(1.5, 0) = 2</code> <code>decimal(2.5, 0) = 2</code>
<code>floor(n)</code>	number	return greatest integer $\leq n$	<code>floor(1.5) = 1</code> <code>floor(-1.5) = -2</code>
<code>ceiling(n)</code>	number	return smallest integer $\geq n$	<code>ceiling(1.5) = 2</code> <code>ceiling(-1.5) = -1</code>

1. Scale is in the range [-6111..6176]

10.3.4.6 Decision Table

The parameters of the decision table function correspond to the named cells in the figures in clause 8.2 (and also correspond to the metamodel in clause 8.3). As mentioned in clause 10.3.2.8, some parameters contain single-quoted (literal) unary tests. The semantics of a decision table is specified by first composing these unary tests into simple expressions that are mapped to the semantic domain, and composed into rule matches, then rule hits, and finally the decision table output(s). These compositions are defined in Table 63.

Table 63: Semantics of decision table

Parameter name (* means optional)	Domain
input expression list	a list of the $N \geq 0$ input expressions in display order
input values list*	a list of N input values, corresponding to the input expressions. Each list element is a unary tests literal (see below).

outputs*	a name (a string matching grammar rule 27) or a list of M>0 names
output values*	if outputs is a list, then output values is a list of lists of values, one list per output; else output values is a list of values for the one output. Each value is a string.
rule list	a list of R>0 rules. A rule is a list of N input entries followed by M output entries. An input entry is a unary tests literal. An output entry is an expression.
hit policy*	one of: "U", "A", "P", "F", "R", "O", "C", "C+", "C#", "C<", "C>" (default is "U")
default output value*	if outputs is a list, then default output value is a context with entries composed of outputs and output values; else default output value is one of the output values.

Unary tests (grammar rule 17) are used to represent both input values and input entries. An input expression e is said to *satisfy* an input entry t (with optional input values v), depending on the syntax of t , as follows:

- grammar rule 17.a: FEEL(e in (t))=**true**
- grammar rule 17.b: FEEL(e in (t))=**false**
- grammar rule 17.c when v is not provided: **e != null**
- grammar rule 17.c when v is provided: FEEL(e in (v))=**true**

A rule with input entries t_1, t_2, \dots, t_N is said to *match* the input expression list $[e_1, e_2, \dots, e_N]$ (with optional input values list $[v_1, v_2, \dots, v_N]$) if e_i *satisfies* t_i (with optional input values v_i) for all i in $1..N$.

A rule is *hit* if it is matched and the hit policy indicates that the matched rule's output value should be included in the decision table result. Each hit results in one output value (multiple outputs are collected into a single context value). Therefore, multiple hits require aggregation.

The hit policy is specified using the initial letter of one of the following boldface policy names.

Single hit policies:

- **Unique** – only a single rule can be matched.
- **Any** – multiple rules can match, but they all have the same output,
- **Priority** – multiple rules can match, with different outputs. The output that comes first in the supplied *output values* list is returned,
- **First** – return the first match in rule order,

Multiple hit policies:

- **Collect** – return a list of the outputs in arbitrary order,
- **Rule order** – return a list of outputs in rule order,
- **Output order** – return a list of outputs in the order of the *output values* list

The Collect policy may optionally specify an *aggregation*, as follows:

- **C+** – return the sum of the outputs
- **C#** – return the count of the outputs
- **C<** – return the minimum-valued output
- **C>** – return the maximum-valued output

The *aggregation* is defined using the following built-in functions specified in clause 10.3.4.4: *sum*, *count*, *minimum*, *maximum*. To reduce complexity, decision tables with compound outputs do not support aggregation and support only the following hit policies: *Unique*, *Any*, *Priority*, *First*, *Collect without operator*, and *Rule order*.

A decision table may have no rule hit for a set of input values. In this case, the result is given by the default output value, or **null** if no default output value is specified. A complete decision table SHALL NOT specify a default output value.

The semantics of a decision table invocation **DTI** are as follows:

1. Every rule in the rule list is matched with the input expression list. Matching is unordered.
2. If no rules match,
 - a. if a default output value *d* is specified, **DTI**=FEEL(*d*)
 - b. else **DTI**=**null**.
3. Else let *m* be the sublist of rules that match the input expression list. If the hit policy is "First" or "Rule order", order *m* by rule number.
 - a. Let *o* be a list of output expressions, where the expression at index *i* is the output expression from rule *m*[*i*]. The output expression of a rule in a single output decision table is simply the rule's output entry. The output expression of a multiple output decision table is a context with entries composed from the output names and the rule's corresponding output entries. If the hit policy is "Output order", the decision table SHALL be single output and *o* is ordered consistent with the order of the *output values*.
 - b. If a multiple hit policy is specified, **DTI**=FEEL(aggregation(*o*)), where aggregation is one of the built-in functions *sum*, *count*, *minimum* as specified in 10.3.4.4
 - c. else **DTI**=FEEL(*o*[1]).

10.3.4.7 Sort

Sort a list using an ordering function. For example,

sort(list: [3,1,4,5,2], precedes: function(x,y) x < y) = [1,2,3,4,5]

Table 64: Semantics of sort functions

Parameter name (* means optional)	Domain
list	list of any element, be careful with nulls
precedes	boolean function of 2 arguments defined on every pair of list elements

10.4 Execution Semantics of Decision Services

FEEL gives execution semantics to decision services defined in decision models where FEEL is the expression language. A decision service is semantically equivalent to a FEEL function whose parameters are the decision service inputs, and whose logic is a context assembled from the decision service's decisions and knowledge requirements.

Every FEEL expression in a decision model has execution semantics. `LiteralExpression` (FEEL text) semantics is defined in 10.3. Boxed expressions described in 10.2.2 can be mapped to FEEL text and thus also have execution semantics.

Recall that a `DecisionService` is defined by four lists: `inputData`, `inputDecisions`, `outputDecisions`, and `encapsulatedDecisions`. The lists are not independent and thus not all required to be specified, e.g. each required decision (direct and indirect) of the `outputDecisions` must be an `encapsulatedDecision`, an `inputDecision`, or required by an `inputDecision`. For simplicity in the following, we assume that all four lists are correctly and completely specified.

A `DecisionService` is given execution semantics by mapping it to a FEEL function F . Let D be a `DecisionService` with input data id_1, id_2, \dots , input decisions di_1, di_2, \dots , encapsulated decisions de_1, de_2, \dots , and output decisions do_1, do_2, \dots . Each input data id_i has a name $id_i.n$. Each decision d_i has a name $d_i.n$ and a decision logic expression $d_i.e$. The decisions may require `BusinessKnowledgeModels` bkm_1, bkm_2, \dots . BKMs have names $bkm_i.n$ and encapsulated logic $bkm_i.f$. The syntax for FEEL function F is $function(id_1.n, id_2.n, \dots, di_1.n, di_2.n, \dots) C.result$, where C is the context

```
{
   $bkm_{1.n} : bkm_{1.f}, bkm_{2.n} : bkm_{2.f}, \dots,$ 
   $de_{1.n} : de_{1.e}, de_{2.n} : de_{2.e}, \dots,$ 
   $result: \{do_{1.n} : do_{1.e}, do_{2.n} : do_{2.e}, \dots\}$ 
}
```

such that bkm_i, de_i and do_i are partially ordered by requirements (e.g. the context entry for a required decision comes before a decision that requires it).

The execution semantics of D is $FEEL(F)$: a function that when invoked with values from the FEEL semantic domain bound to the parameters representing input data and input decisions, returns a context consisting of all the output decisions' output values.

XML elements SHALL map to the FEEL semantic domain as specified in section 10.3.3. Otherwise, details of the syntax of input/output data values and mapping to/from FEEL are undefined.

10.5 Metamodel

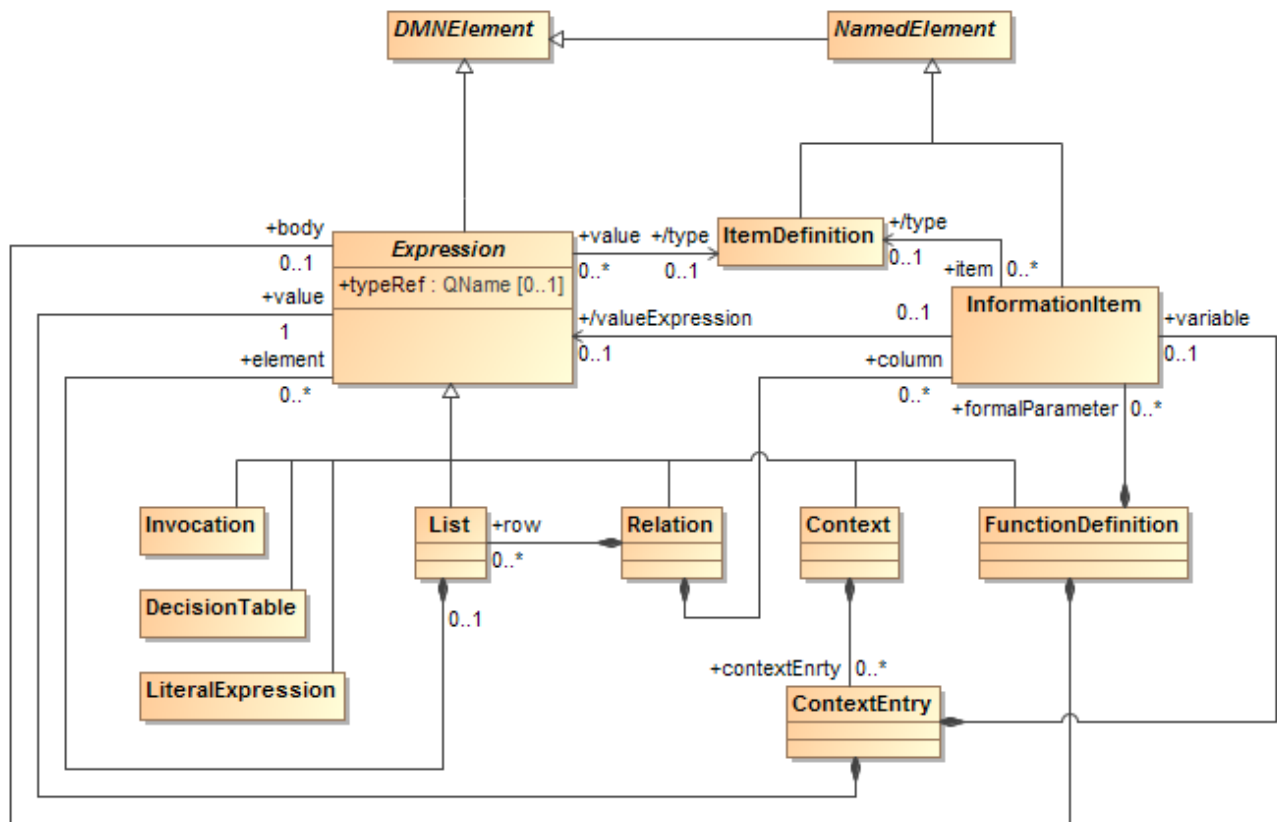

Figure 67: Expression class diagram

The class Expression is extended to support the four new kinds of boxed expressions introduced by FEEL, namely: Context, FunctionDefinition, Relation and List.

Boxed expressions are Expressions that have a standard diagrammatic representation (see clauses 7.2.1 and 10.2.1). FEEL *contexts*, *function definitions*, *relations* and *lists* SHOULD be modeled as Context, FunctionDefinition, Relation and List elements, respectively, and represented as a boxed expression whenever possible; that is, when they are top-level expressions, since an instance of LiteralExpression cannot contain another Expression element.

10.5.1 Context metamodel

A Context is composed of any number of contextEntries, which are instances of ContextEntry.

A Context element is represented diagrammatically as a **boxed context** (clause 10.2.1.4). A FEEL *context* (grammar rule 59 and clause 10.3.2.6) SHOULD be modeled as a Context element whenever possible.

Context inherits all the attributes and model associations from Expression. Table 65 presents the additional attributes and model associations of the Context element.

Table 65: Context attributes and model association

Attribute	Description
contextEntry: ContextEntry [*]	This attributes lists the instances of ContextEntry that compose this Context.

10.5.2 ContextEntry metamodel

The class ContextEntry is used to model FEEL *context entries* when a *context* is modeled as a Context element.

An instance of ContextEntry is composed of an optional variable, which is an InformationItem element whose name is the *key* in the *context entry*, and of a value, which is the instance of Expression that models the *expression* in the *context entry*.

Table 66 presents the attributes and model associations of the ContextEntry element.

Table 66: ContextEntry attributes and model associations

Attribute	Description
variable: InformationItem [0..1]	The instance of InformationItem that is contained in this ContextEntry, and whose name is the <i>key</i> in the modeled <i>context entry</i>
value: Expression	The instance of Expression that is the <i>expression</i> in this ContextEntry

10.5.3 FunctionDefinition metamodel

A FunctionDefinition has formalParameters and a body. A FunctionDefinition element is represented diagrammatically as a **boxed function**, as described in clause 0. A FEEL *function definition* (grammar rule 57 and clause 10.3.2.12) SHOULD be modeled as a FunctionDefinition element whenever possible.

FunctionDefinition inherits all the attributes and model associations from Expression. Table 67 presents the additional attributes and model associations of the FunctionDefinition element.

Table 67: FunctionDefinition attributes and model associations

Attribute	Description
FormalParameter: InformationItem [*]	This attributes lists the instances of InformationItem that are the parameters of this Context.
body: Expression [0..1]	The instance of Expression that is the body in this FunctionDefinition

10.5.4 List metamodel

A `List` is simply a list of `element`, which are instances of `Expressions`. A `List` element is represented diagrammatically as a **boxed list**, as described in clause 10.2.1.5. A FEEL *list* (grammar rule 56 and clause 10.3.2.12) SHOULD be modeled as a `List` element whenever possible.

`List` inherits all the attributes and model associations from `Expression`. Table 68 presents the additional attributes and model associations of the `List` element.

Table 68: List attributes and model associations

Attribute	Description
element: <code>Expression</code> [*]	This attributes lists the instances of <code>Expression</code> that are the elements in this <code>List</code> .

10.5.5 Relation metamodel

A `Relation` is convenient shorthand for a list of similar contexts. A `Relation` has a `column` instead of repeated `ContextEntry`s, and a `List` is used for every row, with one of the `List`'s `expression` for each column value.

`Relation` inherits all the attributes and model associations from `Expression`. Table 69 presents the additional attributes and model associations of the `Relation` element.

Table 69: Relation attributes and model associations

Attribute	Description
row: <code>List</code> [*]	This attributes lists the instances of <code>List</code> that compose the rows of this <code>Relation</code> .
column: <code>InformationItem</code> [*]	This attributes lists the instances of <code>InformationItem</code> that define the columns in this <code>Relation</code> .

10.6 Examples

A good way to get a quick overview of FEEL is by example.

FEEL expressions may reference other FEEL expressions by name. Named expressions are contained in a context. Expressions are evaluated in a scope, which is a list of contexts in which to resolve names. The result of the evaluation is an element in the FEEL semantic domain.

10.6.1 Context

Figure 68 shows the boxed context used for the examples. Such a context could arise in several ways. It could be part of the decision logic for a single, complex decision. Or, it could be a context that is equivalent to part of a DRG as defined in

clause 10.4, where *applicant*, *requested product*, and *credit history* are input data instances, *monthly income* and *monthly outgoings* are sub-decisions, and *PMT* is a business knowledge model.

applicant	age	51	
	maritalStatus	"M"	
	existingCustomer	false	
	monthly	income	10000
repayments		2500	
expenses		3000	
requested product	product type	"STANDARD LOAN"	
	rate	0.25	
	term	36	
	amount	100000.00	
monthly income	applicant.monthly.income		
monthly outgoings	applicant.monthly.repayments, applicant.monthly.expenses		
credit history	record date	event	weight
	date("2008-03-12")	"home mortgage"	100
	date("2011-04-01")	"foreclosure warning"	150
PMT	(rate, term, amount)		
	$(\text{amount} * \text{rate} / 12) / (1 - (1 + \text{rate} / 12)^{-\text{term}})$		

Figure 68: Example context

Notice that there are 6 top-level context entries, represented by the six rows of the table. The value of the context entry named 'applicant' is itself a context, and the value of the context entry named 'monthly' is itself a context. The value of the context entry named 'monthly outgoings' is a list, the value of the context entry named 'credit history' is a relation, *i.e.* a list of two contexts, one context per row. The value of the context entry named 'PMT' is a function with parameters 'rate', 'term', and 'amount'.

The following examples use the above context. Each example has a pair of equivalent FEEL expressions separated by a horizontal line. Both expressions denote the same element in the semantic domain. The second expression, the 'answer', is a literal value.

10.6.2 Calculation

monthly income * 12

120000

The context defines *monthly income* as *applicant.monthly.income*, which is also defined in the context as 10,000. Twelve times the *monthly income* is 120,000.

10.6.3 If, In

```
if applicant.maritalStatus in ("M","S") then "valid" else "not valid"  
-----  
"valid"
```

The *in* test determines if the left hand side expression satisfies the list of values or ranges on the right hand side. If satisfied, the *if* expression returns the value of the *then* expression. Otherwise, the value of the *else* expression is returned.

10.6.4 Sum entries of a list

```
sum(monthly outgoings)  
-----  
5500
```

Monthly outgoings is computed in the context as the list [*applicant.monthly.repayments*, *applicant.monthly.expenses*], or [2500, 3000]. The square brackets are not required to be written in the boxed context.

10.6.5 Invocation of user-defined PMT function

The PMT function defined in the context computes the monthly payments for a given interest rate, number of months, and loan amount.

```
PMT (requested product . rate,  
     requested product . term,  
     requested product . amount)  
-----  
3975.982590125562
```

A function is invoked textually using a parenthesized argument list after the function name. The arguments are defined in the context, and are 0.25, 36, and 100,000, respectively.

10.6.6 Sum weights of recent credit history

```
sum(credit history[record date > date("2011-01-01")].weight)  
-----  
150
```

This is a complex "one-liner" that will be useful to expand into constituent sub-expressions:

- built-in: *sum*
 - path expression ending in *.weight*
 - filter: [*record date* > *date("2011-01-01")*]
 - name resolved in context: *credit history*

An expression in square brackets following a list expression filters the list. *Credit history* is defined in the context as a relation, that is, a list of similar contexts. Only the last item in the relation satisfies the filter. The first item is too old. The path expression ending in *.weight* selects the value of the *weight* entry from the context or list of contexts satisfied by the filter. The *weight* of the last item in the credit history is 150. This is the only item that satisfies the filter, so the sum is 150 as well.

10.6.7 Determine if credit history contain a bankruptcy event

```
some ch in credit history satisfies ch.event = "bankruptcy"
```

false

The *some* expression determines if at least one element in a list or relation satisfies a test. There are no bankruptcy events in the credit history in the context.

11 DMN Example

In this section we present an example of the use of **DMN** to model and execute decision-making in a simple business process modeled in **BPMN**, including decisions to be automated in decision services called from the business process management system.

11.1 The business process model

Figure 69 shows a simple process for loan originations, modeled in **BPMN 2.0**. The process handles an application for a loan, obtaining data from a credit bureau only if required for the case, and automatically deciding whether the application should be accepted, declined, or referred for human review. If referred, documents are collected from the applicant and a credit officer adjudicates the case. It consists of the following components:

- The **Collect application data** task collects data describing the Requested product and the Applicant (e.g. through an on-line application form).
- The **Decide bureau Strategy** task calls a decision service, passing Requested product and Applicant data. The service returns two decisions: Strategy and Bureau call type.
- A **gateway** uses the value of Strategy to route the case to Decline application, Collect bureau data or Decide routing.
- The **Collect bureau data** task collects data from a credit bureau according to the Bureau call type decision, then the case is passed to Decide routing.
- The **Decide routing** task calls a decision service, passing Requested product, Applicant data and Bureau data (if the Collect bureau data task was not performed, the Bureau data are set to null). The service returns a single decision: Routing.
- A **gateway** uses the value of Routing to route the case to Accept application, Review application or Decline application.
- The **Collect documents** task requests and uploads documents from the applicant in support of their application.
- The **Review application** task allows a credit officer to review the case and decide whether it should be accepted or declined.
- A **gateway** uses the credit officer's Adjudication to route the case to Accept application or Decline application.
- The **Accept application** task informs the applicant that their application is accepted and initiates the product.
- The **Decline application** task informs the applicant that their application is declined.

Note that in this example two decision points (automated as calls to decision services) are represented in **BPMN 2.0** as business rule tasks; the third decision point (which is human decision-making) is represented as a user task.

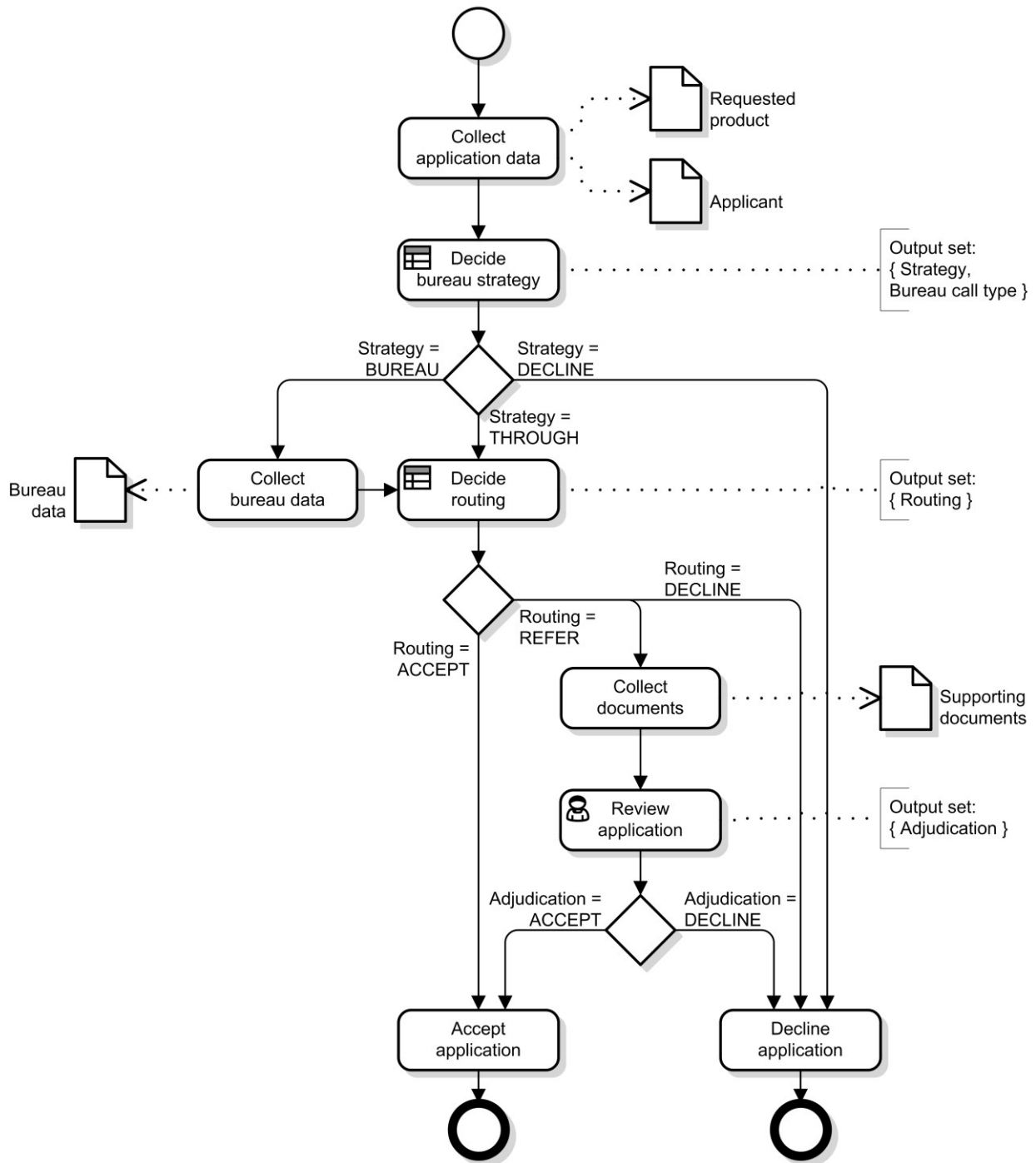

Figure 69: Example business process

11.2 The decision requirements level

Figure 70 shows a DRD of all the decision-making in this business process. There are four sources of input data for the decision-making (Requested product, Applicant data, Bureau data and Supporting documents), and four decisions whose

results are used in the business process (Strategy, Bureau call type, Routing and Adjudication). Between the two are intermediate decisions: evaluations of risk, affordability and eligibility. Notable features of this DRD include:

- It covers both automated and human decision-making
- Some decisions (e.g. Pre-bureau risk category) and input data (e.g. Applicant data) are required by multiple decisions, i.e. the information requirements network is not a tree
- Business knowledge models (see Affordability calculation) may be invoked by multiple decisions
- Business knowledge models (see Credit contingency factor) may be invoked by other business knowledge models
- Some decisions do not have associated business knowledge models
- Knowledge sources may provide authority for multiple decisions and/or business knowledge models.

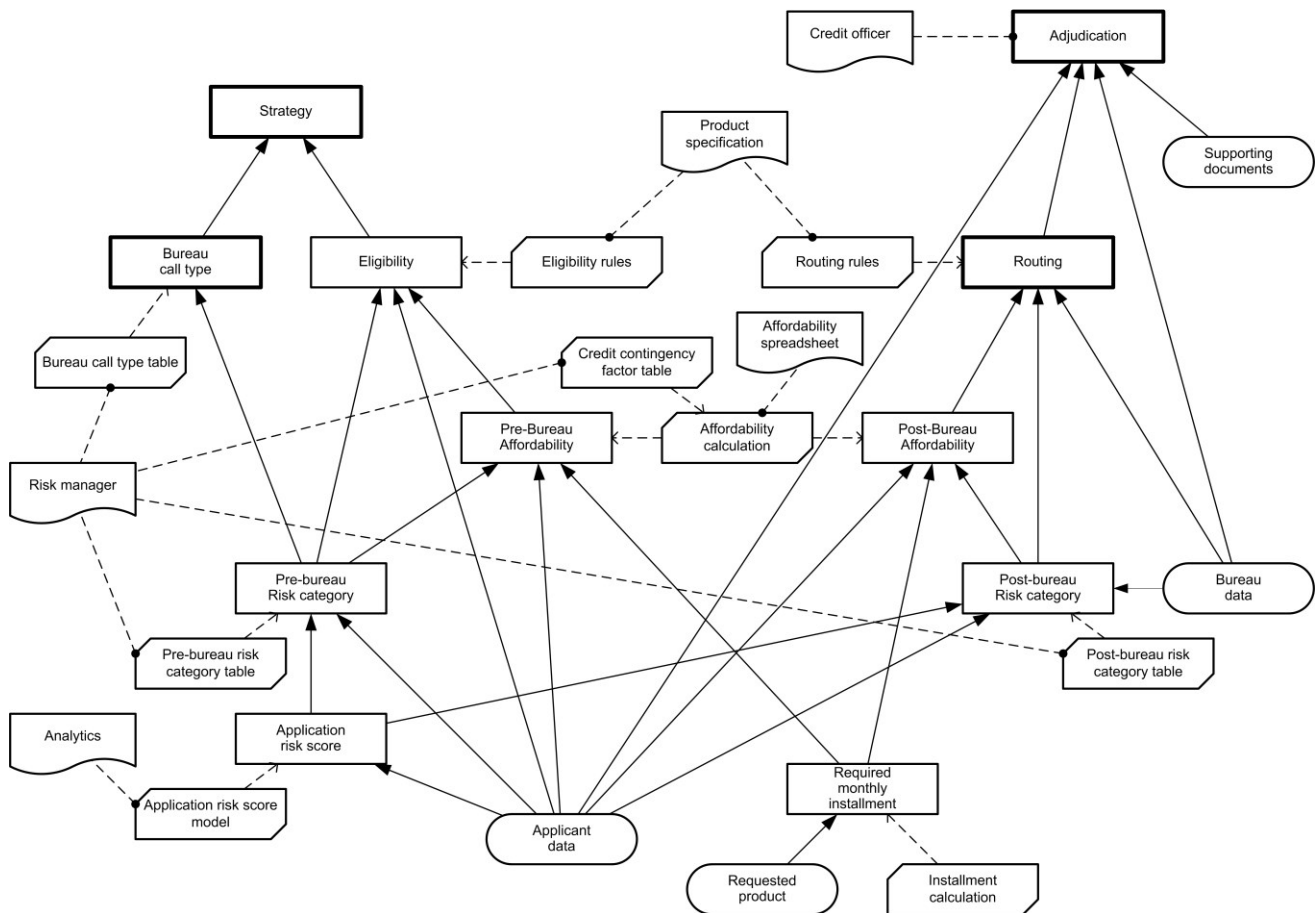

Figure 70: DRD of all automated decision-making

It might be considered more convenient to draw separate (but overlapping) DRDs for the three decision points:

- Figure 71 shows the DRD of the decisions required for the Decide bureau strategy decision point, i.e. the requirements subgraph of the Strategy and Bureau call type decisions. These are decisions to be automated through encapsulation in a decision service called at this point, and therefore need their logic to be specified completely.

- Figure 72 shows the DRD for the Decide routing decision point, i.e. the requirements subgraph of the Routing decision. These are also decisions automated with a decision service, and therefore need their logic to be specified completely. Note that some elements appear in both Figure 71 and Figure 72.
- Figure 73 shows the DRD for the Review application decision point, i.e. the requirements subgraph of the Adjudication decision. This is a human decision and has no associated specification of decision logic, but the DRD indicates that the Credit officer takes into account the results of the automated Routing decision along with the case data, including the Supporting documents. (The requirements subgraph of the Routing decision has been hidden in this DRD.)

All four DRDs – Figure 70, Figure 71, Figure 72 and Figure 73 – are views of the same DRG.

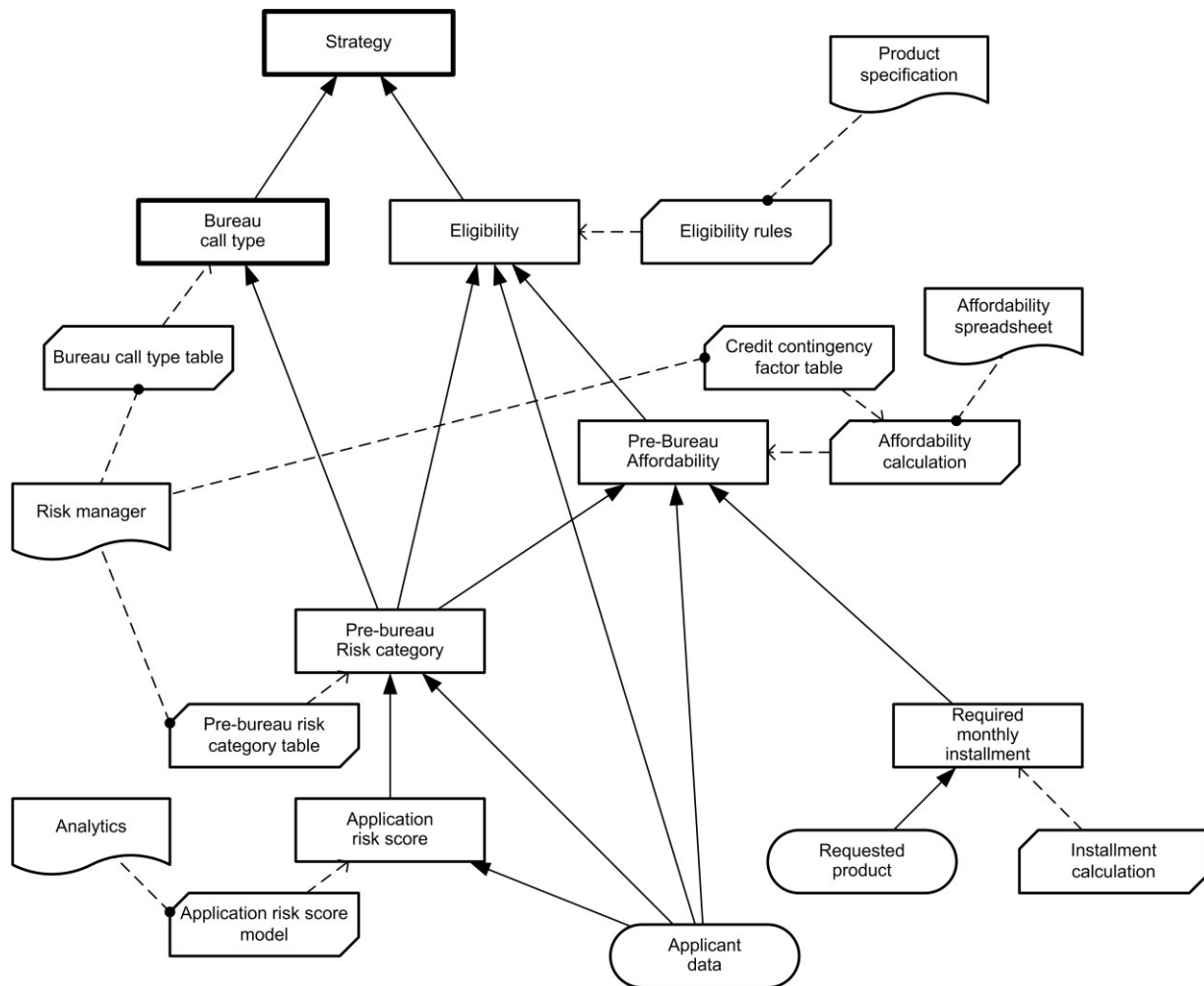

Figure 71: DRD for Decide bureau strategy decision point

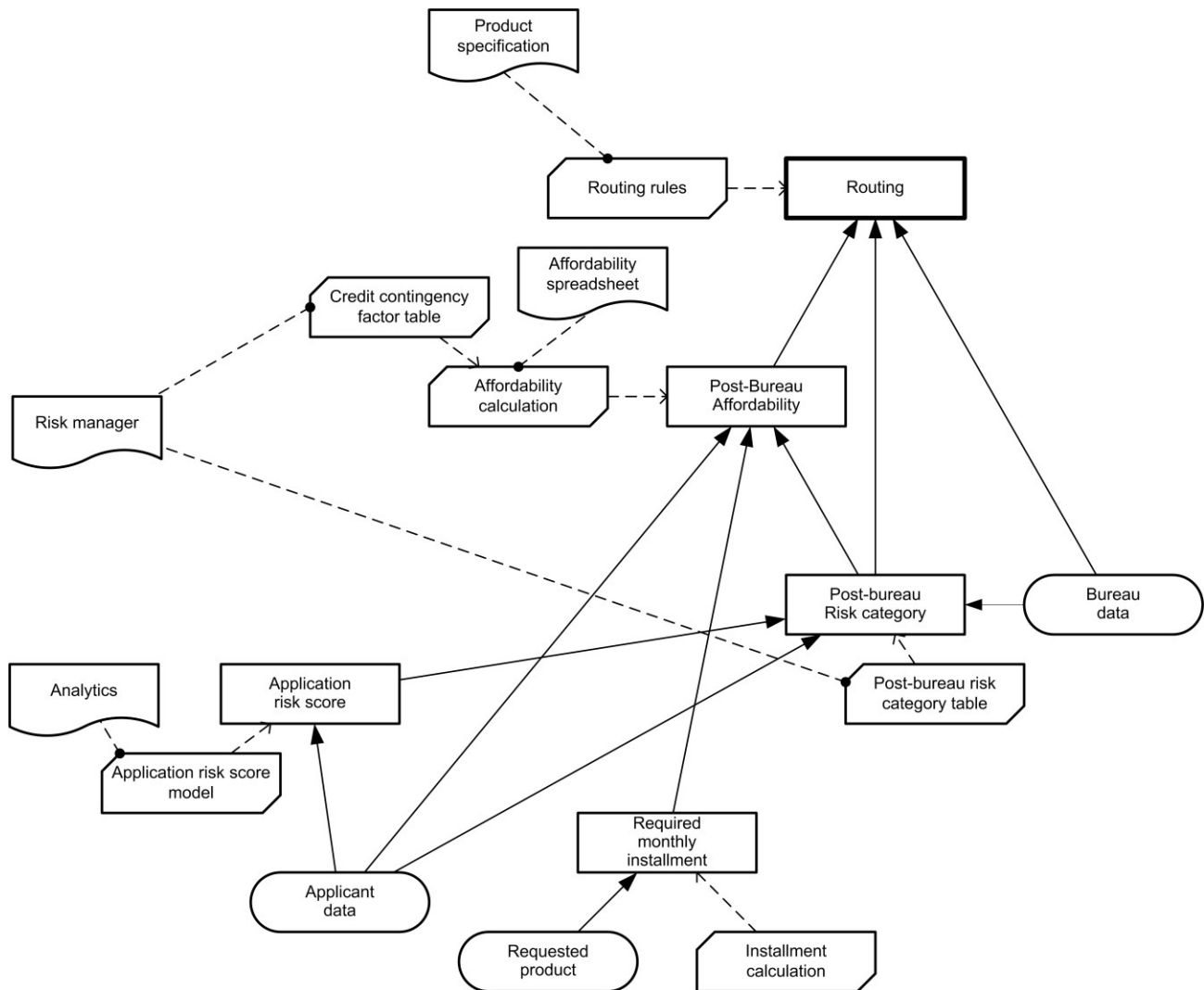

Figure 72: DRD for Decide routing decision point

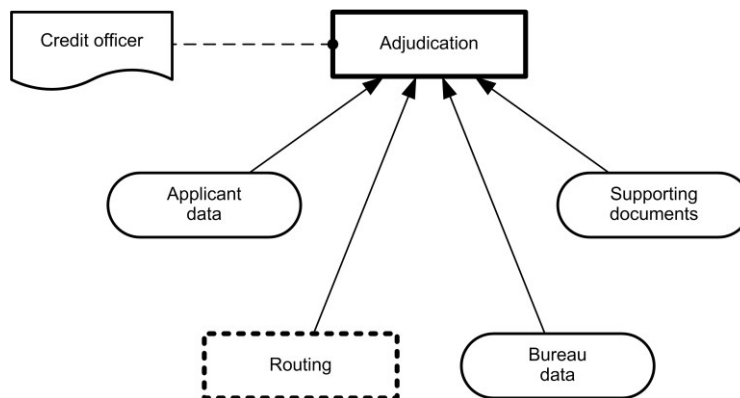

Figure 73: DRD for Review application decision point

The DRG depicted in these DRDs shows dependencies between the following decisions:

- The **Strategy** decision, requiring the Bureau call type and Pre-bureau eligibility decisions, invokes the Strategy table shown in Figure 76 (without that table being encapsulated in a business knowledge model)
- The **Bureau call type** decision, requiring the Pre-bureau risk category decision, invokes the Bureau call type table shown in Figure 78
- The **Eligibility** decision, requiring Applicant data and the Pre-bureau risk category and Pre-bureau affordability decisions, invokes the Eligibility rules shown in Figure 80
- The **Pre-bureau affordability** decision, requiring Applicant data and the Pre-bureau risk category and Required monthly installment decisions, invokes the Affordability calculation boxed expression shown in Figure 91, which in turn invokes the Credit contingency factor table shown in Figure 92
- The **Pre-bureau risk category** decision, requiring Applicant data and the Application risk score decision, invokes the Pre-bureau risk category table shown in Figure 82
- The **Application risk score** decision, requiring Applicant data, invokes the score model shown in Figure 84
- The **Routing** decision, requiring Bureau data and the Post-bureau affordability and Post-bureau risk category decisions, invokes the Routing rules shown in Figure 86
- The **Post-bureau affordability** decision, requiring Applicant data and the Post-bureau risk score and Required monthly installment decisions, invokes the Affordability calculation boxed expression shown in Figure 91, which in turn invokes the Credit contingency factor table shown in Figure 92
- The **Post-bureau risk category** decision, requiring Applicant and Bureau data and the Application risk score decision, invokes the Post-bureau risk category table shown in Figure 88.
- The **Required monthly installment** decision, requiring Requested product data, invokes the Installment calculation boxed expression shown in Figure 94.
- The **Adjudication decision** requiring Applicant data, Bureau data, Supporting documents, and the Routing decision, has no associated decision logic.

The two decision services required by the business process model may now be defined against the decision model. The **Bureau Strategy Decision Service**, called by the **Decide bureau strategy** task, has output decisions {Bureau call type, Strategy}, and is shown in Figure 74. The **Routing Decision Service**, called by the **Decide routing** task, has output decisions {Routing}, and is shown in Figure 75.

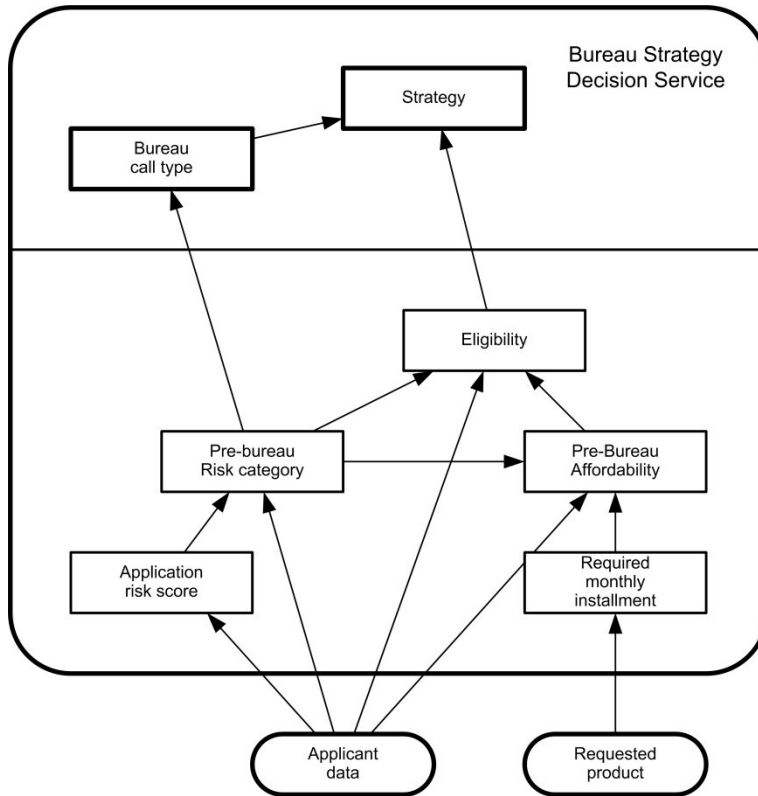

Figure 74: Bureau Strategy Decision Service

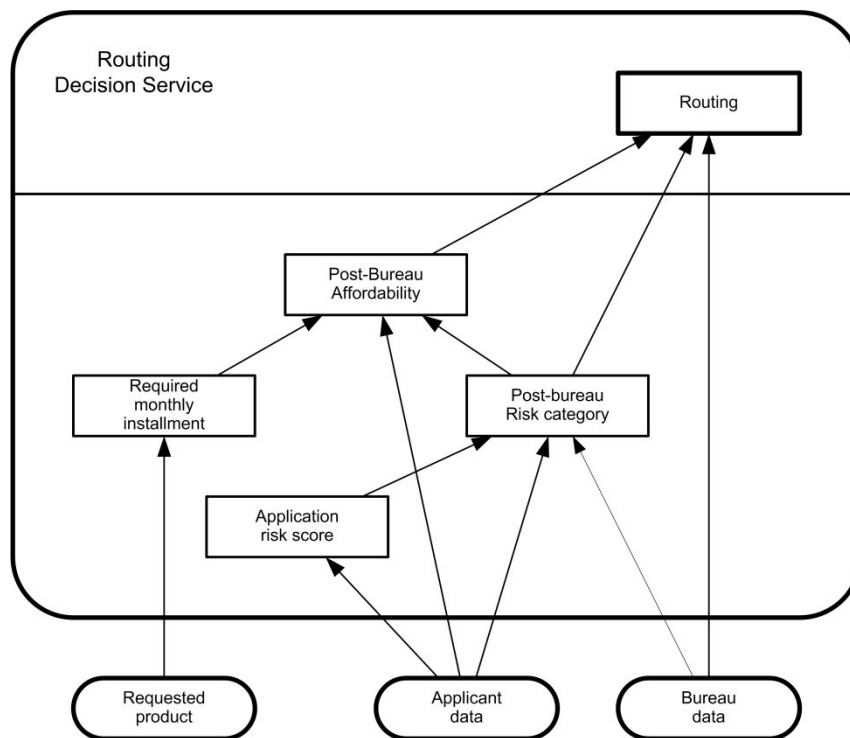

Figure 75: Routing Decision Service

11.3 The decision logic level

The DRG in Figure 70 is defined in more detail in the following specifications of the value expressions associated with decisions and business knowledge models:

- The **Strategy** decision logic (Figure 76) defines a complete, unique-hit decision table deriving Strategy from Eligibility and Bureau Call Type.
- The **Bureau Call Type** decision logic (shown as a boxed invocation in Figure 77) invokes the Bureau call type table, passing the output of the Pre-bureau risk category decision as the Pre-Bureau Risk Category parameter.
- The **Bureau call type table** decision logic (Figure 78) defines a complete, unique-hit decision table deriving Bureau Call Type from Pre-Bureau Risk Category.
- The **Eligibility** decision logic (shown as a boxed invocation in Figure 79) invokes the Eligibility rules business knowledge model, passing Applicant data . Age as the Age parameter, the output of the Pre-bureau risk category decision as the Pre-Bureau Risk Category parameter, and the output of the Pre-bureau affordability decision as the Pre-Bureau Affordability parameter.
- The **Eligibility Rules** decision logic (Figure 80) defines a complete, priority-ordered single hit decision table deriving Eligibility from Pre-Bureau Risk Category, Pre-Bureau Affordability and Age.
- The **Pre-Bureau Risk Category** decision logic (shown as a boxed invocation in Figure 81) invokes the Pre-bureau risk category table business knowledge model, passing Applicant data . ExistingCustomer as the Existing Customer parameter and the output of the Application risk score decision as the Application Risk Score parameter.
- The **Pre-Bureau Risk Category Table** decision logic (Figure 82) defines a complete, unique-hit decision table deriving Pre-Bureau Risk Category from Existing Customer and Application Risk Score.
- The **Application Risk Score** decision logic (shown as a boxed invocation in Figure 83) invokes the Application risk score model business knowledge model, passing Applicant data . Age as the Age parameter, Applicant data . MaritalStatus as the Marital Status parameter and Applicant data . EmploymentStatus as the Employment Status parameter.
- The **Application Risk Score Model** decision logic (Figure 84) defines a complete, no-order multiple-hit table with aggregation, deriving Application risk score from Age, Marital Status and Employment Status, as the sum of the Partial scores of all matching rows (this is therefore a predictive scorecard represented as a decision table).
- The **Routing** decision logic (shown as a boxed invocation in Figure 85) invokes the Routing rules business knowledge model, passing Bureau data . Bankrupt as the Bankrupt parameter, Bureau data . CreditScore as the Credit Score parameter, the output of the Post-bureau risk category decision as the Post-Bureau Risk Category parameter, and the output of the Post-bureau affordability decision as the Post-Bureau Affordability parameter. Note that if Bureau data is null (due to the THROUGH strategy bypassing the Collect bureau data task) the Bankrupt and Credit Score parameters will be null.
- The **Routing Rules** decision logic (Figure 86) defines a complete, priority-ordered single hit decision table deriving Routing from Post-Bureau Risk Category, Post-Bureau Affordability, Bankrupt and Credit Score.
- The **Post-Bureau Risk Category** decision logic (shown as a boxed invocation in Figure 87) invokes the Post-bureau risk category business knowledge model, passing Applicant data . ExistingCustomer as the Existing Customer parameter, Bureau data . CreditScore as the Credit Score parameter, and the output of the Application risk score decision as the Application Risk Score parameter. Note that if Bureau data is null (due to the THROUGH strategy bypassing the Collect bureau data task) the Credit Score parameter will be null.
- The **Post-bureau risk category table** decision logic (Figure 88) defines a complete, unique-hit decision table deriving Post-Bureau Risk Category from Existing Customer, Application Risk Score and Credit Score.
- The **Pre-bureau Affordability** decision logic (shown as a boxed invocation in Figure 89) invokes the Affordability calculation business knowledge model, passing Applicant data . Monthly . Income as the Monthly

Income parameter, Applicant data . Monthly . Repayments as the Monthly Repayments parameter, Applicant data . Monthly . Expenses as the Monthly Expenses parameter, the output of the Pre-bureau risk category decision as the Risk Category parameter, and the output of the Required monthly installment decision as the Required Monthly Installment parameter.

- The **Post-bureau affordability** decision logic (shown as a boxed invocation in Figure 90) invokes the Affordability calculation business knowledge model, passing Applicant data . Monthly . Income as the Monthly Income parameter, Applicant data . Monthly . Repayments as the Monthly Repayments parameter, Applicant data . Monthly . Expenses as the Monthly Expenses parameter, the output of the Post-bureau risk category decision as the Risk Category parameter, and the output of the Required monthly installment decision as the Required Monthly Installment parameter.
- The **Affordability calculation** decision logic (Figure 91) defines a boxed function deriving Affordability from Monthly Income, Monthly Repayments, Monthly Expenses and Required Monthly Installment. One step in this calculation derives Credit contingency factor by invoking the Credit contingency factor table business knowledge model, passing the output of the Risk category decision as the Risk Category parameter.
- The **Credit contingency factor table** decision logic (Figure 92) defines a complete, unique-hit decision table deriving Credit contingency factor from Risk Category.
- The **Required monthly installment** decision logic (shown as a boxed invocation in Figure 93) invokes the Installment calculation business knowledge model, passing Requested product . ProductType as the Product Type parameter, Requested product . Rate as the Rate parameter, Requested product . Term as the Term parameter, and Requested product . Amount as the Amount parameter.
- The **Installment calculation** decision logic (Figure 94) defines a boxed function deriving monthly installment from Product Type, Rate, Term and Amount. One step in this calculation invokes an external function PMT, equivalent to the PMT calculation defined in Figure 68.

Strategy			
U	Eligibility	Bureau Call Type	Strategy
1	<i>INELIGIBLE</i>	-	<i>DECLINE</i>
2	<i>ELIGIBLE</i>	<i>FULL, MINI</i>	<i>BUREAU</i>
3		<i>NONE</i>	<i>THROUGH</i>

Figure 76: Strategy decision logic

Bureau call type	
Bureau call type table	
Pre-Bureau Risk Category	Pre-Bureau Risk Category

Figure 77: Bureau Call Type decision logic

Bureau call type table		
U	Pre-Bureau Risk Category	Bureau Call Type
1	HIGH, MEDIUM	FULL
2	LOW	MINI
3	VERY LOW, DECLINE	NONE

Figure 78: Bureau call type table decision logic

Eligibility	
Eligibility rules	
Age	Applicant data . Age
Pre-Bureau Risk Category	Pre-bureau risk category
Pre-Bureau Affordability	Pre-bureau affordability

Figure 79: Eligibility decision logic

Eligibility rules				
P	Pre-Bureau Risk Category	Pre-Bureau Affordability	Age	Eligibility
				INELIGIBLE, ELIGIBLE
1	DECLINE	-	-	INELIGIBLE
2	-	false	-	INELIGIBLE
3	-	-	< 18	INELIGIBLE
4	-	-	-	ELIGIBLE

Figure 80: Eligibility rules decision logic

Pre-bureau risk category	
Pre-bureau risk category table	
Existing Customer	Applicant data . ExistingCustomer
Application Risk Score	Application risk score

Figure 81: Pre-Bureau Risk Category decision logic

Pre-bureau risk category table			
U	Existing Customer	Application Risk Score	Pre-Bureau Risk Category
1	false	< 100	<i>HIGH</i>
2		[100..120)	<i>MEDIUM</i>
3		[120..130]	<i>LOW</i>
4		> 130	<i>VERY LOW</i>
5	true	< 80	<i>DECLINE</i>
6		[80..90)	<i>HIGH</i>
7		[90..110]	<i>MEDIUM</i>
8		> 110	<i>LOW</i>

Figure 82: Pre-bureau risk category table decision logic

Application risk score	
Application risk score model	
Age	Applicant data . Age
Marital Status	Applicant data . MaritalStatus
Employment Status	Applicant data . EmploymentStatus

Figure 83: Application Risk Score decision logic

Application risk score model				
C+	Age	Marital Status	Employment Status	Partial score
	[18..120]	S, M	UNEMPLOYED, EMPLOYED, SELF-EMPLOYED, STUDENT	
1	[18..21]	-	-	32
2	[22..25]	-	-	35
3	[26..35]	-	-	40
4	[36..49]	-	-	43
5	>=50	-	-	48
6	-	S	-	25
7	-	M	-	45
8	-	-	UNEMPLOYED	15
9	-	-	STUDENT	18
10	-	-	EMPLOYED	45
11	-	-	SELF-EMPLOYED	36

Figure 84: Application risk score model decision logic

Routing	
Routing rules	
Bankrupt	Bureau data . Bankrupt
Credit Score	Bureau data . CreditScore
Post-Bureau Risk Category	Post-bureau risk category
Post-Bureau Affordability	Post-bureau affordability

Figure 85: Routing decision logic

Routing rules					
P	Post-Bureau Risk Category	Post-Bureau Affordability	Bankrupt	Credit Score	Routing
				null, [0..999]	<i>DECLINE, REFER, ACCEPT</i>
1	-	false	-	-	<i>DECLINE</i>
2	-	-	true	-	<i>DECLINE</i>
3	<i>HIGH</i>	-	-	-	<i>REFER</i>
4	-	-	-	< 580	<i>REFER</i>
5	-	-	-	-	<i>ACCEPT</i>

Figure 86: Routing rules decision logic

Post-bureau risk category	
Post-bureau risk category table	
Existing Customer	Applicant data . ExistingCustomer
Credit Score	Bureau data . CreditScore
Application Risk Score	Application risk score

Figure 87: Post-Bureau Risk Category decision logic

Post-bureau risk category table				
U	Existing Customer	Application Risk Score	Credit Score	Post-Bureau Risk Category
1	false	< 120	< 590	HIGH
2			[590..610]	MEDIUM
3			> 610	LOW
4		[120..130]	< 600	HIGH
5			[600..625]	MEDIUM
6			> 625	LOW
7		> 130	-	VERY LOW
8	true	<= 100	< 580	HIGH
9			[580..600]	MEDIUM
10			> 600	LOW
11		> 100	< 590	HIGH
12			[590..615]	MEDIUM
13			> 615	LOW

Figure 88: Post-bureau risk category table decision logic

Pre-bureau affordability	
Affordability calculation	
Monthly Income	Applicant data . Monthly . Income
Monthly Repayments	Applicant data . Monthly . Repayments
Monthly Expenses	Applicant data . Monthly . Expenses
Risk Category	Pre-bureau risk category
Required Monthly Installment	Required monthly installment

Figure 89: Pre-Bureau Affordability decision logic

Post-bureau affordability	
Affordability calculation	
Monthly Income	Applicant data . Monthly . Income
Monthly Repayments	Applicant data . Monthly . Repayments
Monthly Expenses	Applicant data . Monthly . Expenses
Risk Category	Post-bureau risk category
Required Monthly Installment	Required monthly installment

Figure 90: Post-Bureau Affordability decision logic

Affordability calculation	
(Monthly Income, Monthly Repayments, Monthly Expenses, Risk Category, Required Monthly Installment)	
Disposable Income	Monthly Income – (Monthly Repayments + Monthly Expenses)
Credit Contingency Factor	Credit contingency factor table
	Risk Category Risk Category
Affordability	if Disposable Income * Credit Contingency Factor > Required Monthly Installment then true else false
Affordability	

Figure 91: Affordability calculation decision logic

Credit contingency factor table		
U	Risk Category	Credit Contingency Factor
1	<i>HIGH, DECLINE</i>	0.6
2	<i>MEDIUM</i>	0.7
3	<i>LOW, VERY LOW</i>	0.8

Figure 92: Credit contingency factor table decision logic

Required monthly installment	
Installment calculation	
Product Type	Requested product . ProductType
Rate	Requested product . Rate
Term	Requested product . Term
Amount	Requested product . Amount

Figure 93: Required Monthly Installment decision logic

Installment calculation	
(Product Type, Rate, Term, Amount)	
Monthly Fee	if Product Type = "STANDARD LOAN" then 20.00 else if Product Type = "SPECIAL LOAN" then 25.00 else null
Monthly Repayment	PMT(Rate, Term, Amount)
Monthly Repayment + Monthly Fee	

Figure 94: Installment calculation decision logic

11.4 Executing the Decision Model

In order to execute a decision model (in this case, by calling two decision services), case data must be bound to the input data, much as an invocation binds arguments to function parameters. The binding of case data to input data, however, is not part of the decision model, unlike the invocation that specifies how a decision's requirement inputs bind to the parameters of that decision's required knowledge.

FEEL allows contexts and other expressions to be used to represent case data (see also clauses 10.3.3.3 and 10.6.1). Input data is associated with an item definition (clause 7.3.2), and the case data must have the same type and other constraints specified by the item definition. Case data must be mapped to the FEEL domain. For example, XML instance data is mapped to the FEEL domain as described in clause 10.3.3.

For convenience, we will specify case data using boxed expressions instead of XML. Figure 95, Figure 96 and Figure 97 show boxed contexts defining case data for Applicant data, Requested product and Bureau data.

Applicant data		
Age	51	
MaritalStatus	M	
EmploymentStatus	EMPLOYED	
ExistingCustomer	false	
Monthly	Income	10,000.00
	Repayments	2,500.00
	Expenses	3,000.00

Figure 95: Applicant Data input data sample

Requested product	
ProductType	STANDARD LOAN
Rate	0.08
Term	36
Amount	100,000.00

Figure 96: Requested Product input data sample

Bureau data	
Bankrupt	false
CreditScore	600

Figure 97: Bureau Data input data sample

When the Bureau Strategy Decision Service is called with the Applicant data and Requested product case data, it returns the context shown in Figure 98:

Strategy	THROUGH
Bureau Call Type	NONE

Figure 98: Output of the Bureau Strategy Decision Service

When the Routing Decision Service is called with the Applicant data, Requested product and Bureau data case data, it returns the context shown in Figure 99.

Routing	<i>ACCEPT</i>
---------	---------------

Figure 99: Output of the Routing decision Service

12 Exchange formats

12.1 Interchanging Incomplete Models

It is common for **DMN** models to be interchanged before they are complete. This occurs frequently when doing iterative modeling, where one user (such as a knowledge source expert or business user) first defines a high-level model and then passes it on to another person to complete or refine the model.

Such "incomplete" models are ones in which not all of the mandatory model attributes have been filled in yet or the cardinality of the lower bound of attributes and associations has not been satisfied.

XMI allows for the interchange of such incomplete models. In **DMN**, we extend this capability to interchange of XML files based on the **DMN** XML-Schema. In such XML files, implementers are expected to support this interchange by:

- Disregarding missing attributes that are marked as "required" in the **DMN** XML-Schema.
- Reducing the lower bound of elements with "minOccurs" greater than 0.

12.2 Machine Readable Files

All machine-readable files, including XSD, XMI and XML files, can be found in OMG Document dtc/15-11-12 , which is a flat zip file.

- For the **DMN** XMI Model, the main file is DMN.xmi.
- For the **DMN** XSD Interchange (supporting Conformance Levels 1, 2 and 3), the main file is DMN.xsd.
- A serialization of the example in clause 11 is provided in ch11example

12.3 XSD

12.3.1 Document Structure

A domain-specific set of model elements is interchanged in one or more **DMN** files. The root element of each file SHALL be `<DMN:Definitions>`. The set of files SHALL be self-contained, i.e. all definitions that are used in a file SHALL be imported directly or indirectly using the `<DMN:Import>` element.

Each file SHALL declare a "namespace" that MAY differ between multiple files of one model.

DMN files MAY import non-**DMN** files (such as XSDs and PMMLs) if the contained elements use external definitions.

12.3.2 References within the DMN XSD

Many **DMN** elements that may need to be referenced contain IDs and within the **BPMN** XSD, references to elements are expressed via these IDs. The XSD IDREF type is the traditional mechanism for referencing by IDs, however it can only reference an element within the same file. **DMN** elements of type `DMNElementReference` support referencing by ID, across files, by utilizing an `href` attribute whose value must be a valid URI reference [RFC 3986] where the path components may be absolute or relative, the reference has no query component, and the fragment consists of the value of the `id` of the referenced **DMN** element.

For example, consider the following `Decision`:

```
<decision name="Pre-Bureau Risk Category" id="prebureauriskDec01">...</decision>
```

When this `Decision` is referenced, e.g. by an `InformationRequirement` in a `Decision` that is defined in another file, the reference could take the following form:

```
<requiredDecision  
href="http://www.example.org/Definitions01.xml#prebureauriskDec01"/>
```

where “<http://www.example.org/Definitions01.xml>” is an URI reference to the XML document in which the “Pre-Bureau Risk Category” Decision is defined (e.g. the value of the `locationURI` attribute in the corresponding `Import` element), and “prebureauriskDec01” is the value of the `id` attribute for the Decision.

If the path component in the URI reference is relative, the base URI against which the relative reference is applied is determined as specified in [RFC 3986]. According to that specification, “*if no base URI is embedded and the representation is not encapsulated within some other entity, then, if a URI was used to retrieve the representation, that URI shall be considered the base URI*” ([RFC 3986], section 5.1.3). That is, if the reference is not in the scope of an `xml:base` attribute [XBASE], a value of the `href` attribute that contains only a fragment and no path component references a **DMN** element that is defined in the same instance of XML file as the referencing element. In the example below, assuming that the `requiredDecision` element is not in the scope of an `xml:base` attribute, the **DMN** element whose `id` is “prebureauriskDec01” must be defined in the same XML document:

```
<requiredDecision href="#prebureauriskDec01" />
```

Notice that the **BPMN** processes and tasks that use a decision are referenced using the `href` attribute as well: indeed, it is compatible with the system to reference external `Process` and `Task` instances in **BPMN 2.0** Definitions, which is also based on IDs.

References to datatypes (XSD attribute `@typeRef`) are by name, not ID. In order to support imported types, `@typeRef` is type QName, in which the prefix refers to the namespace of the imported XSD or **DMN** file. To reference base types and non-imported `ItemDefinitions`, the prefix may be omitted.

ANNEXES

All the Annexes are informative.

Annex A discuss issues around the application of **DMN** in combination with **BPMN**. This section is intended to provide some direction to practitioners but is non-normative.

Annex B provides a non-normative glossary to aid comprehension of the specification.

Annex A. Relation to BPMN

(Informative)

1. Goals of BPMN and DMN

The OMG Business Process Model and Notation standard provides a standard notation for describing business processes as orchestrations of tasks. The success of **BPMN** has provided a major motivation for **DMN**, and business decisions described using **DMN** are expected to be commonly deployed in business processes described using **BPMN**.

All statements pertaining to **BPMN** below are from the OMG document reference 11-01-03 unless otherwise stated.

BPMN's goals are stated in the specification and provide easy comparisons to **DMN**:

- Goal 1: *“The primary goal of **BPMN** is to provide a notation that is readily understandable by all business users, from the business analysts that create the initial drafts of the processes, to the technical developers responsible for implementing the technology that will perform those processes, and finally, to the business people who will manage and monitor those processes. Thus, **BPMN** creates a standardized bridge for the gap between the business process design and process implementation.”* **DMN** users will also be business analysts (designing decisions) and then business users (populating decision models such as decision tables). Technical developers may be responsible for mapping business terms to appropriate data technologies. Therefore **DMN** can also be said to bridge the decision design by a business analyst, and the decision implementation, typically using some decision execution technology,
- Goal 2: *“... To ensure that XML languages designed for the execution of business processes, such as WSBPEL (Web Services Business Process Execution Language), can be visualized with a business-oriented notation.”* It is not a stated goal of **DMN** to be able to visualize other XML languages (such as W3C RIF or OMG PRR); indeed it is expected that **DMN** would provide the MDA specification layer for such languages. It does not preclude however the use of **DMN** (such as decision tables) to represent executable forms (such as production rules).
- Goal 3: *“The intent of **BPMN** is to standardize a business process model and notation in the face of many different modeling notations and viewpoints. In doing so, **BPMN** will provide a simple means of communicating process information to other business users, process implementers, customers, and suppliers.”* Similarly, the intent of **DMN** is to standardize the decision model and notation across the many different implementations of broadly semantically similar models. In so doing, **DMN** will also facilitate the communication of decision information across business communities and tools.

2. BPMN Tasks and DMN Decisions

Most **BPMN** diagrams contain some tasks which involve decision-making which can be modeled in **DMN**. These tasks take input data acquired or generated earlier in the process, and produce decision outputs which are used later in the process. Decision outputs may be used in two principal ways:

- They may be consumed in another process task
- They may influence the choice of sequence flows out of a gateway.

In the latter case, decisions are used to determine which subprocesses or tasks are to be executed (in the process sense). As such, **DMN** complements **BPMN** as decision modeling complements process modeling (in the sense of defining orchestrations or work tasks).

For example, Figure 100 shows an example¹ of a **BPMN**-defined process.

¹ Shipment Process in a Hardware Retailer example, Ch5.1, BPMN 2.0 By Example, June 2010, OMG reference 10-06-02

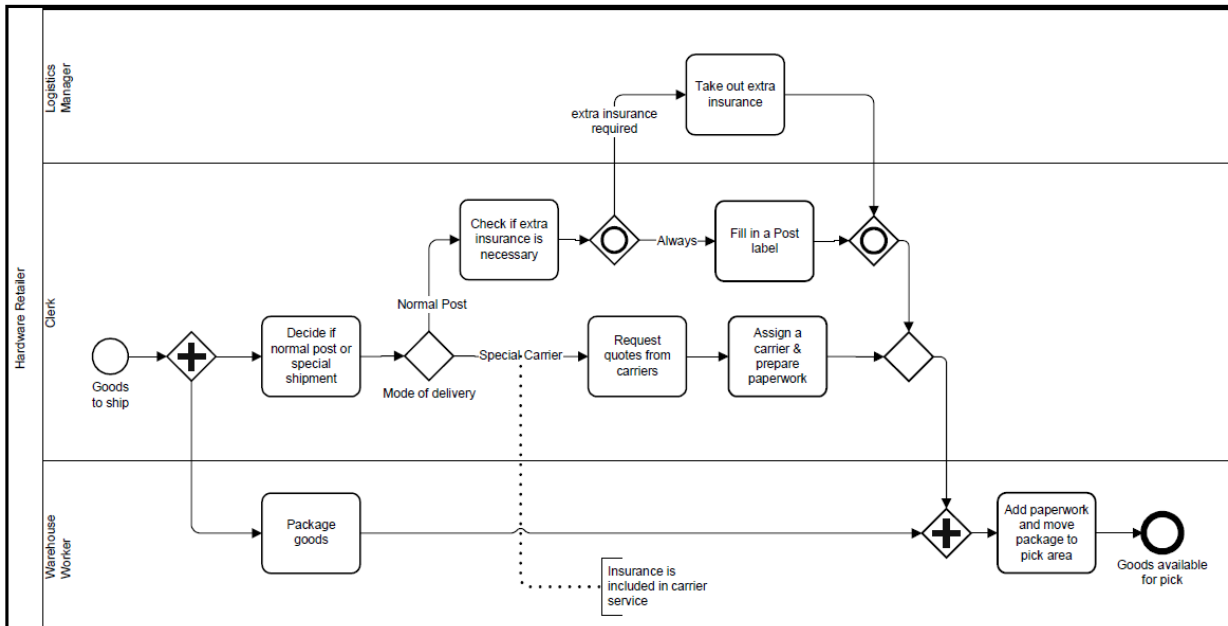

Figure 100: Decision-making in BPMN

Analyzing this we see:

- a task whose title starts with “Decide...” which makes a decision on (whether to use) normal post or special shipment, and which precedes an exclusive gateway using that decision result
- a task whose title starts with “Check...” which makes a decision on whether extra insurance is necessary, which precedes an inclusive gateway for which an additional process path may be executed based on the decision result
- a task whose title starts with “Assign...” which implies a decision to select a carrier based on some selection criteria. The previous task is effectively collecting data for this decision. In an automated system this would probably be a subprocess embedding a decision and some other activities (such as “prepare paperwork”).





From this example we can see that even a simple business process in **BPMN** may have several decision-making tasks.

3. Types of BPMN Tasks relevant to DMN

BPMN defines² different types of tasks that can be considered for decision-making roles. The relevant tasks are as shown in Table 70:

² See ch 10.2.3 in the **BPMN** Specification.

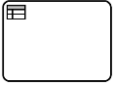
Table 70: BPMN tasks relevant to DMN

	Task type(s)	Decision role
1	<p>Loop Multi-Instance Compensation</p> 	None explicitly. Although a process for a decision may make iterations or loop (such as production rules executing Run To Completion cycles in a Rete-based rules engine), these are not considered relevant at the business modeling level.
2	<p>Service Task </p>	Decision tasks will be executed (when automated) by a decision service. However a decision model is not guaranteed to be executed automatically in a business process.
3	<p>User Task </p>	Decision tasks executed manually as a part of a workflow-oriented business process may be specified as a User Task.
4	<p>Business Rule Task </p>	The Business Rule Task was defined in BPMN 2 as a placeholder for (business-rule-driven) decisions, and is the natural placeholder for a decision task. <i>Note that business rules (as defined in OMG SBVR) can constrain any type of process activity, not just business decisions.</i>
5	<p>Script Task </p>	Decision tasks may today be encoded using business process script languages.

A future version of **BPMN** may choose to clarify and extend the definitions of task to better match decision modeling requirements and **DMN** – to wit, to define a **BPMN** Decision Task as some task used to make a decision modeled with **DMN**. In the meantime, the Business Rule Task is the most natural way to express this functionality. However, as noted in clauses 5.2.2 and 6.3.6, a Decision in **DMN** can be associated with any Task, allowing for flexibility in implementation.

4. Process gateways and Decisions

Process gateways can be considered of 2 types:

1. A gateway that determines a process route or routes based on existing data
2. A gateway that determines a process route or routes based on the outcome of one or more decisions that are determined by some previous task within the process.

In the latter case, a Decision Task (task used to make a decision using **DMN**) may need an extended notation to clarify the relationship of the decision task to the gateway(s) that use it.

5. Linking BPMN and DMN Models

DMN offers two approaches to linking business process models in **BPMN** with decision models; one normative and the other non-normative:

a) Associating Decisions with Tasks and Processes

As described in clause 6.3.6, in **DMN 1.1**, the process context for an instance of `Decision` is defined by its association with any number of `usingProcesses`, which are instances of `Process` as defined in **OMG BPMN 2**, and any number of `usingTasks`, which are instances of `Task` as defined in **OMG BPMN 2**. Each decision may therefore be associated with one or more business processes (to indicate that the decision is taken during those processes), and/or with one or more specific tasks (to indicate that the tasks involve making the decision). An implementation **SHALL** allow these associations to be defined for each decision.

An implementation **MAY** perform validation over the two (**BPMN** and **DMN**) models, to check, for example, that:

- A Decision is not associated with Tasks that are part of Processes not also associated with the Decision
- A Decision is not associated with Tasks that are not part of any Process associated with the Decision

During development it may be appropriate to associate a Decision only with a Process, but inconsistency between Task and Process associations is not allowed.

Note that this approach allows the relationships between business process models and decision models to be defined and validated, but does not of itself permit the decisions modeled in **DMN** to be executed automatically by processes modeled in **BPMN**.

b) Decision Services

One approach to decision automation is described non-normatively in **Error! Reference source not found.**: the encapsulation of **DMN** Decisions in a “decision service” called from a **BPMN** Task (e.g. a Service Task or Business Rule Task, as discussed in Annex A.3 above). The `usingProcesses` and `usingTasks` properties allow definition and validation of associations between **BPMN** and **DMN**; the definition of decision services then provides a detailed specification of the required interface.

Annex B. Glossary

(Informative)

A

Aggregation	The production of a single result from multiple hits on a decision table . DMN specifies four aggregation operators on the Collect hit policy, namely: + (sum), < (min), > (max), # (count). If no operator is specified, the results of the Collect hit policy are returned without being aggregated.
Any	A hit policy for single hit decision tables with overlapping decision rules : under this policy any match may be used.
Authority Requirement	The dependency of one element of a Decision Requirements Graph on another element which provides guidance to it or acts as a source of knowledge for it.

B

Binding	In an invocation , the association of the parameters of the invoked expression with the input variables of the invoking expression, using a binding formula.
Boxed Context	A form of boxed expression showing a collection of n (name, value) pairs with an optional result value.
Boxed Expression	A notation serving to decompose decision logic into small pieces which may be associated graphically with elements of a DRD .
Boxed Function	A form of boxed expression showing the kind, parameters and body of a function.
Boxed Invocation	A form of boxed expression showing the parameter bindings that provide the context for the evaluation of the body of a business knowledge model .
Boxed List	A form of boxed expression showing a list of n items.
Boxed Literal Expression	A form of boxed expression showing a literal expression .
Business Context Element	An element representing the business context of a decision: either an organisational unit or a performance indicator .
Business Knowledge Model	Some decision logic (e.g. a decision table) encapsulated as a reusable function, which may be invoked by decisions or by other business knowledge models .

C

Clause	In a decision table , a clause specifies a subject, which is defined by an input expression or an output domain, and the finite set of the sub-domains of the subject's domain that are
--------	--

	relevant for the piece of decision logic that is described by the decision table.
Collect	A hit policy for multiple hit decision tables with overlapping decision rules : under this policy all matches will be returned as a list in an arbitrary order. An operator can be added to specify a function to be applied to the outputs: see Aggregation.
Context	In FEEL , a map of key-value pairs called context entries .
Context Entry	One key-value pair in a context .
Crosstab Table	An orientation for decision tables in which two input expressions form the two dimensions of the table, and the output entries form a two-dimensional grid.
D	
Decision	The act of determining an output value from a number of input values , using decision logic defining how the output is determined from the inputs.
Decision Logic	The logic used to make decisions, defined in DMN as the value expressions of decisions and business knowledge models and represented visually as boxed expressions .
Decision Logic Level	The detailed level of modeling in DMN, consisting of the value expressions associated with decisions and business knowledge models .
Decision Model	A formal model of an area of decision-making, expressed in DMN as decision requirements and decision logic .
Decision Point	A point in a business process at which decision-making occurs, modeled in BPMN 2.0 as a business rule task and possibly implemented as a call to a decision service .
Decision Requirements Diagram	A diagram presenting a (possibly filtered) view of a DRG .
Decision Requirements Graph	A graph of DRG elements (decisions , business knowledge models and input data) connected by requirements .
Decision Requirements Level	The more abstract level of modeling in DMN, consisting of a DRG represented in one or more DRDs .
Decision Rule	In a decision table , a decision rule specifies associates a set of conclusions or results (output entries) with a set of conditions (input entries).
Decision Service	A software component encapsulating a decision model and exposing it as a service, which might be consumed (for example) by a task in a BPMN process model.
Decision Table	A tabular representation of a set of related input and output expressions, organized into decision rules indicating which output entry applies to a specific set of input entries .

Definitions	A container for all elements of a DMN decision model . The interchange of DMN files will always be through one or more Definitions.
DMN Element	Any element of a DMN decision model : a DRG Element , Business Context Element , Expression , Definitions , Element Collection , Information Item or Item Definition .
DRD	See Decision Requirements Diagram .
DRG	See Decision Requirements Graph .
DRG Element	Any component of a DRG : a decision , business knowledge model , input data or knowledge source .

E

Element Collection	Used to define named groups of DRG elements within a Definitions .
Expression	A literal expression , decision table or invocation used to define part of the decision logic for a decision model in DMN . Returns a single value when interpreted.

F

FEEL	The “Friendly Enough Expression Language” which is the default expression language for DMN.
First	A hit policy for single hit decision tables with overlapping decision rules : under this policy the first match is used, based on the order of the decision rules .
Formal Parameter	A named, typed value used in the invocation of a function to provide an information item for use in the body of the function.

H

Hit	In a decision table , the successful matching of all input expressions of a decision rule , making the conclusion eligible for inclusion in the results.
Hit Policy	Indicates how overlapping decision rules have to be interpreted. A single hit table returns the output of one rule only; a multiple hit table may return the output of multiple rules or an aggregation of the outputs.
Horizontal	An orientation for decision tables in which decision rules are presented as rows; clauses as columns.

I

Information Item	A DMN element used to model either a variable or a parameter at the decision logic level in DMN decision models .
------------------	--

Information Requirement	The dependency of a decision on an input data element or another decision to provide a variable used in its decision logic .
Input Data	Denotes information used as an input by one or more decisions , whose value is defined outside of the decision model .
Input Entry	An expression defining a condition cell in a decision table (i.e. the intersection of a decision rule and an input clause).
Input Expression	An expression defining the item to be compared with the input entries of an input clause in a decision table .
Input Value	An expression defining a limited range of expected values for an input clause in a decision table .
Invocation	A mechanism that permits the evaluation of one value expression another, using a number of bindings .
Item Definition	Used to model the structure and the range of values of input data and the outcome of decisions , using a type language such as FEEL or XML Schema.

K

Knowledge Requirement	The dependency of a decision or business knowledge model on a business knowledge model which must be invoked in the evaluation of its decision logic .
Knowledge Source	An authority defined for decisions or business knowledge models , e.g. domain experts responsible for defining or maintaining them, or source documents from which business knowledge models are derived, or sets of test cases with which the decisions must be consistent.

L

Literal Expression	Text that represents decision logic by describing how an output value is derived from its input values, e.g. in plain English or using the default expression language FEEL .
--------------------	---

M

Multiple Hit	A type of decision table which may return output entries from multiple decision rules .
--------------	--

O

Organisational Unit	A business context element representing the unit of an organization which makes or owns a decision .
Orientation	The style of presentation of a decision table : horizontal (decision rules as rows; clauses as columns), vertical (rules as columns; clauses as rows), or crosstab (rules composed from two input dimensions).

Output Entry	An expression defining a conclusion cell in a decision table (i.e. the intersection of a decision rule and an output clause).
Output Order	A hit policy for multiple hit decision tables with overlapping decision rules : under this policy all matches will be returned as a list in decreasing priority order. Output priorities are specified in an ordered list of values.
Output Value	An expression defining a limited range of domain values for an output clause in a decision table .

P

Performance Indicator	A business context element representing a measure of business performance impacted by a decision .
Priority	A hit policy for single hit decision tables with overlapping decision rules : under this policy the match is used that has the highest output priority. Output priorities are specified in an ordered list of values.

R

Relation	A form of boxed expression showing a vertical list of homogeneous horizontal contexts (with no result cells) with the names appearing just once at the top of the list, like a relational table.
Requirement	The dependency of one DRG element on another: either an information requirement , knowledge requirement or authority requirement .
Requirement Subgraph	The directed graph resulting from the transitive closure of the requirements of a DRG element ; i.e. the sub-graph of the DRG representing all the decision-making required by a particular element.
Rule Order	A hit policy for multiple hit decision tables with overlapping decision rules : under this policy all matches will be returned as a list in the order of definition of the decision rules .

S

S-FEEL	A simple subset of FEEL , for decision models that use only simple expressions : in particular, decision models where the decision logic is modeled mostly or only using decision tables .
Single Hit	A type of decision table which may return the output entry of only a single decision rule .

U

Unique

A **hit policy** for **single hit decision tables** in which no overlap is possible and all **decision rules** are exclusive. Only a single rule can be matched.

V

Variable

Represents a value that is input to a **decision**, in the description of its **decision logic**, or a value that is passed as a **parameter** to a function.

Vertical

An **orientation** for **decision tables** in which decision rules are presented as columns; clauses as rows.

W

Well-Formed

Used of a **DRG element** or **requirement** to indicate that it conforms to constraints on referential integrity, acyclicity etc.